



LH0044 Series Precision Low Noise Operational Amplifiers

General Description

The LH0044 Series is a low noise, ultra-stable, high gain, precision operational amplifier family intended to replace either chopper-stabilized monolithic or modular amplifiers. The devices are particularly suited for differential mode, inverting, and non-inverting mode applications requiring very low initial offset, low offset drift, very high gain, high CMRR, and high PSRR. In addition, the LH0044 Series' low initial offset and offset drift eliminate costly and time consuming null adjustments at the systems level. The superior performance afforded by the LH0044 Series is made possible by advanced processing and testing techniques, as well as active laser trim of critical metal film resistors to minimize offset voltage and drift. Unique construction eliminates thermal feedback effects.

The LH0044 Series is an excellent choice for a wide range of precision applications including strain gauge bridges, thermocouple amplifiers, and ultrastable reference ampli-

fers. The LH0044 is guaranteed over the temperature range of -55°C to $+125^{\circ}\text{C}$, and the LH0044AC, LH0044B, and LH0044C are guaranteed from -25°C to $+85^{\circ}\text{C}$. The device is available in standard TO-5 op amp pin out and is compatible with LM108A, LM725, and LM741 type amplifiers.

Features

- Low input offset voltage 25 μV max
- Excellent long-term stability $\pm 1\mu\text{V}/\text{month}$ max
- Low offset drift 0.5 $\mu\text{V}/^{\circ}\text{C}$ max
- Very low noise 0.7 $\mu\text{Vp-p}$ max 0.1 Hz to 10 Hz
- High CMRR and PSRR 120 dB min
- High open loop gain 120 dB min
- Wide common-mode range $\pm 13\text{V}$ min
- Wide supply voltage range $\pm 2\text{V}$ to $\pm 20\text{V}$

Equivalent Circuit

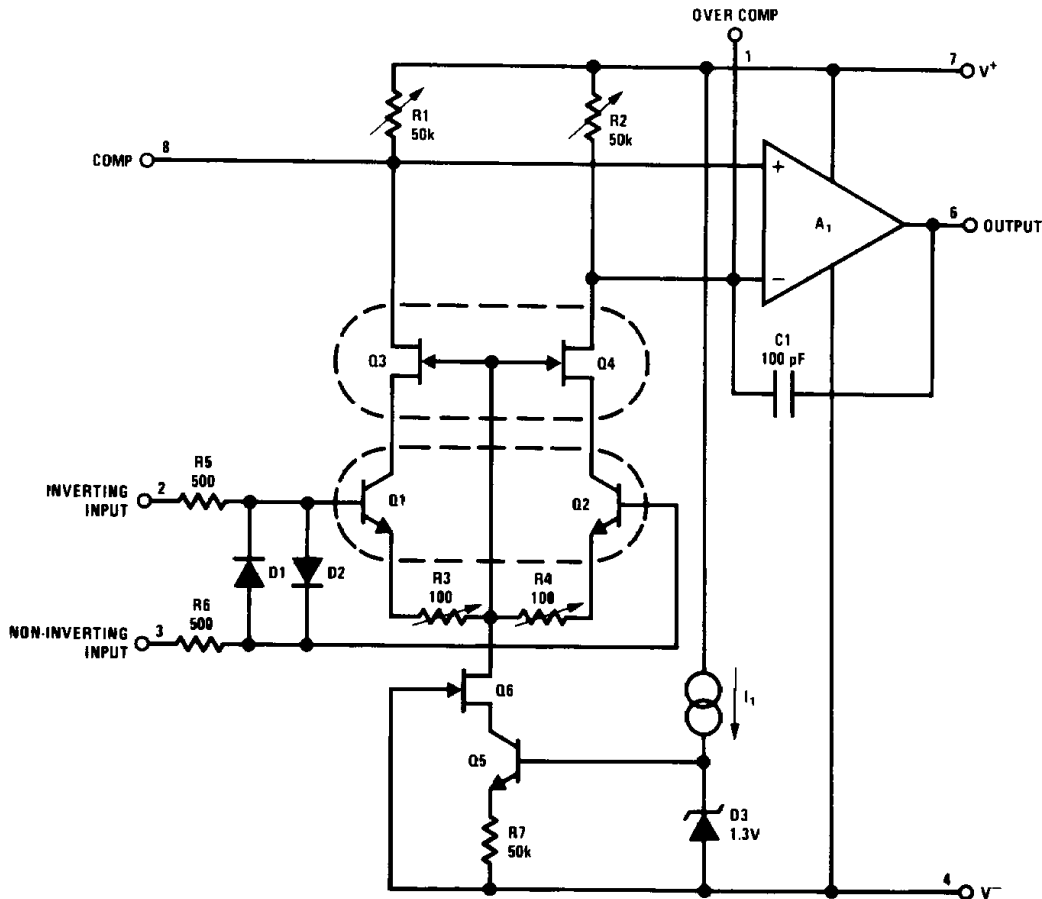

TL/K/5551-1

Absolute Maximum Ratings

If Military/Aerospace specified devices are required, please contact the National Semiconductor Sales Office/Distributors for availability and specifications. (Note 6)

Supply Voltage	±20V
Power Dissipation	600 mW
Differential Input Voltage (Note 4)	±1V
Input Voltage (Note 5)	±15V

Output Short-Circuit Duration	Continuous
Operating Temperature Range	
LH0044	-55°C to +125°C
LH0044AC, LH0044B, LH0044C	-25°C to +85°C
Storage Temperature Range	-65°C to +150°C
Lead Temperature (Soldering, 10 sec.)	260°C
ESD rating to be determined.	

DC Electrical Characteristics (Note 1)

Parameter	Conditions	Limits						Units
		LH0044AC			LH0044/ LH0044B/LH0044C			
		Min	Typ	Max	Min	Typ	Max	
Input Offset Voltage	$T_A = 25^\circ\text{C}$, $R_S = 50\Omega$, $V_{CM} = 0\text{V}$ LH0044C Only		8	25		12	50 100	μV μV
Input Offset Voltage	$R_S = 50\Omega$, $V_{CM} = 0\text{V}$ LH0044A and LH0044B Only			55 75			180 80	μV μV
Average Input Offset Voltage Drift	$T_{Min} \leq T_A \leq T_{Max}$ LH0044B Only		0.1	0.5		0.2	1.3 0.5	$\mu\text{V}/^\circ\text{C}$ $\mu\text{V}/^\circ\text{C}$
Long-Term Stability	(Note 2)		0.2	1		0.3	2	$\mu\text{V}/\text{month}$
Input Noise Voltage (Note 3)	$BW = 0.1\text{ Hz to } 10\text{ Hz}$, $R_S = 50\Omega$ $R_S = 10\text{ k}\Omega$ Imbalance		0.35 0.50	0.7 0.9		0.35 0.50	0.8 1.0	$\mu\text{Vp-p}$ $\mu\text{Vp-p}$
Thermal Feedback Coefficient			0.005			0.005		$\mu\text{V}/\text{mW}$
Open Loop Voltage Gain	$R_L = 10\text{ k}\Omega$	120	145		114	140		dB
Common-Mode Rejection Ratio	$-10\text{V} \leq V_{CM} \leq +10\text{V}$	120	145		114	140		dB
Power Supply Rejection Ratio	$\pm 3\text{V} \leq V_S \leq \pm 18\text{V}$	120	145		114	140		dB
Input Voltage Range		±13	±13.8		±12	±13.5		V
Output Voltage Swing	$R_L = 10\text{ k}\Omega$	±13	±13.7		±12	±13.5		V
Input Offset Current	$25^\circ\text{C} \leq T_A \leq T_{Max}$ $T_{Min} \leq T_A < 25^\circ\text{C}$		1.0	2.5 5.0		1.5	5.0 10.0	nA nA
Average Input Offset Current Drift			5	40		15	80	$\text{pA}/^\circ\text{C}$
Input Bias Current	$25^\circ\text{C} \leq T_A \leq T_{Max}$ $T_{Min} \leq T_A < 25^\circ\text{C}$		8.5	15 50		10	30 100	nA nA
Average Input Bias Current Drift			50	300		100	600	$\text{pA}/^\circ\text{C}$
Differential Input Impedance		5	10		2.5	8		$\text{M}\Omega$
Common Mode Input Impedance			2×10^{11}			2×10^{11}		Ω
Supply Current	$I_L = 0$		0.9	3.0		1.0	4.0	mA
Power Dissipation			27	90		30	120	mW

AC Electrical Characteristics $T_A = 25^\circ\text{C}, V_S = \pm 15\text{V}$

Parameter	Conditions	Typ	Units
Input Noise Voltage	$R_S = 1\text{ k}\Omega, f_O = 10\text{ Hz}$	11	$\text{nV}/\sqrt{\text{Hz}}$
	$R_S = 1\text{ k}\Omega, f_O = 1\text{ kHz}$	9	$\text{nV}/\sqrt{\text{Hz}}$
Slew Rate	$A_V = +1, R_L = 10\text{ k}\Omega, V_{IN} = \pm 10\text{V}$	0.06	$\text{V}/\mu\text{s}$
Large Signal Bandwidth	$A_V = +1, R_L = 10\text{ k}\Omega, V_{IN} = \pm 10\text{V}$	1	kHz
Overload Recovery Time	$A_V = +100, V_{IN} = -100\text{ mV}, \Delta V_{IN} = 200\text{ mV}$	5	μs
Small Signal Bandwidth	$A_V = +1, R_L = 10\text{ k}\Omega$	400	kHz
Small Signal Rise Time	$A_V = +1, R_L = 10\text{ k}\Omega, V_{IN} = 10\text{ mV}$	2.5	μs
Overshoot	$A_V = +1, R_L = 10\text{ k}\Omega, V_{IN} = 10\text{ mV}, C_L = 100\text{ pF}$	10	%

Note 1: All specifications apply for all device grades, at $V_S = \pm 15\text{V}$, and from T_{Min} to T_{Max} unless otherwise specified. T_{Min} is -55°C and T_{Max} is $+125^\circ\text{C}$ for the LH0044. T_{Min} is -25°C and T_{Max} is $+85^\circ\text{C}$ for the LH0044AC, LH0044B and LH0044C. Typical values are given for $T_A = 25^\circ\text{C}$.

Note 2: This parameter is not 100% tested; however, 90% of the devices are guaranteed to meet this specification after one month of operation and after initial turn-on stabilization.

Note 3: Noise is 100% tested on the LH0044AC and LH0044B only. 90% of the LH0044 and LH0044C devices are guaranteed to meet this specification.

Note 4: The inputs are shunted by back-to-back diodes for over-voltage protection. Excessive current will flow for differential input voltages in excess of 1V. Input current should be limited to less than 1 mA.

Note 5: For supply voltages less than $\pm 15\text{V}$, the absolute maximum input voltage is equal to the supply voltage.

Note 6: Refer to RETS0044AH for LH0044AH military specifications and RETS0044H for LH0044H military specifications.

Typical Performance Characteristics

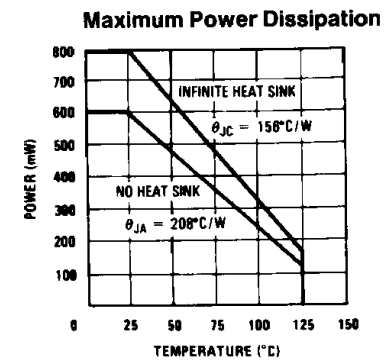
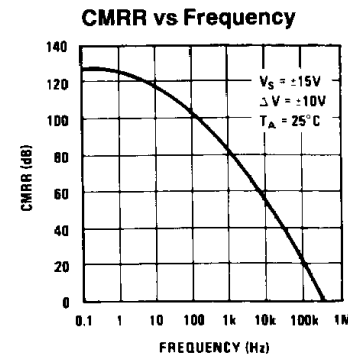
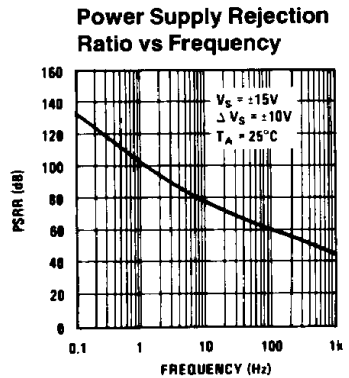
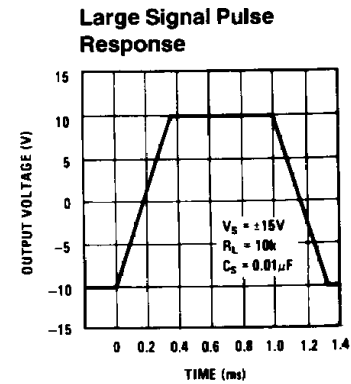
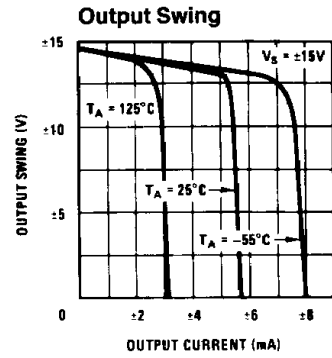
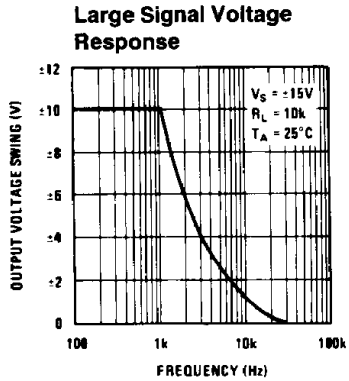
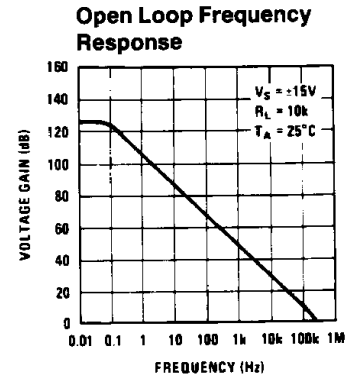
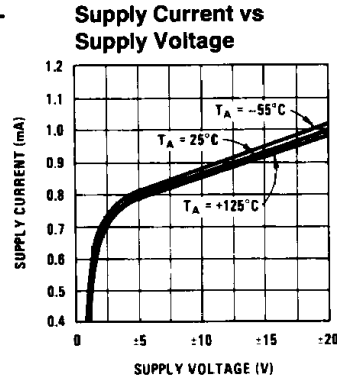
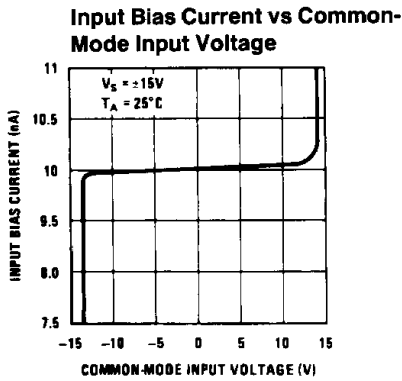
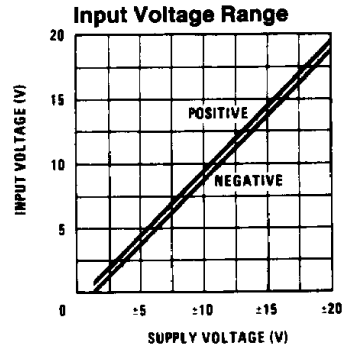
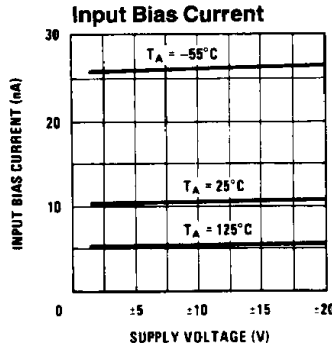
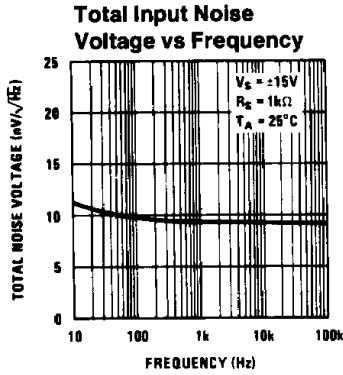

Applications Information

LOW DRIFT CONSIDERATIONS

Achieving ultra-low drift in practical applications requires strict attention to board layout, thermocouple effects, and input guarding. For specific recommendations refer to AN-63 and AN-79.

A point worth stressing with regard to low drift specifications is testing of the LH0044. Simply stated—it is virtually impossible to test the device using a thermoprobe or other form of local heating. A one degree centigrade temperature gradient can account for tens of microvolts of virtual offset (or drift). The test circuit of *Figure 1* is recommended for use in a stabilized oven or continuously stirred oil bath with the entire circuit inside the oven or bath. Isothermal layout of the resistors is advised in order to minimize thermocouple induced EMF's.

OVER COMPENSATION

The LH0044 may be overcompensated in order to minimize noise bandwidth by paralleling the internal 100 pF capacitor with an external capacitor connected between pins 1 and 6. Unity gain frequency may be predicted by:

$$f = \frac{4 \times 10^{-5}}{100 \text{ pF} + C_{\text{ext}} \text{ pF}} \text{ (Hz)}$$

COMPENSATION

For closed loop gains in excess of 10, no external components are required for frequency stability. However, for gains of 10 or less, a 0.01µF disc capacitor is recommended between pin 7 (V⁺) and pin 8 (Comp). An improvement in ac PSRR will also be realized by use of the 0.01µF capacitor.

OFFSET NULL

In general, further nulling of LH0044 is neither necessary nor recommended. For most applications the specified initial offset is sufficient.

However, for those applications requiring additional null, an obvious temptation might be to place a pot between pins 1 and 8 with the wiper returned to V⁺. This technique will usually result in reduced gain and increased offset drift due to mismatch in the TCR of the pot and R1 and R2. The technique is, therefore, not generally recommended.

The recommended technique for offset nulling the LH0044 is shown in *Figure 2*. Null is accomplished in A₂ and all errors are divided by the closed loop gain of the LH0044. Additional offset and drift incurred due to the use of A₂ is less than 1µV/V for V⁺ and V⁻ changes and 0.01µV/°C drift for the values shown in *Figure 2*.

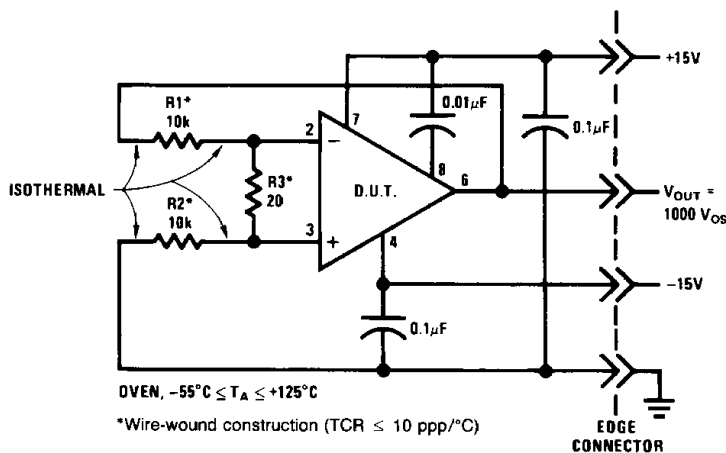

FIGURE 1. LH0044 Temperature Test Circuit

TL/K/5551-4

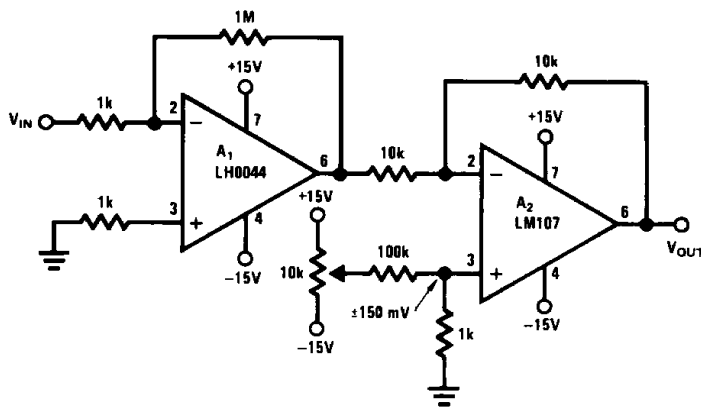
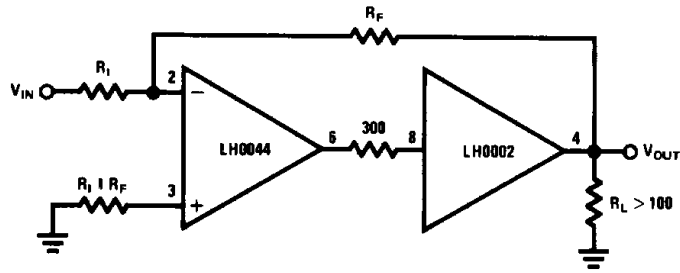

FIGURE 2. LH0044 Null Technique

TL/K/5551-5

Typical Applications

Buffered Output for Heavy Loads



TL/K/5551-6

X1000 Instrumentation Amp

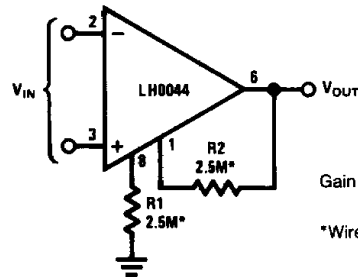

Gain = $9m R_L$
 $\geq 0.2 \times 10^3 (R_1 + R_2)$ for $V_{IN} \leq 10$ mV

*Wire-wound resistors

TL/K/5551-7

Precision Dual Tracking Regulator

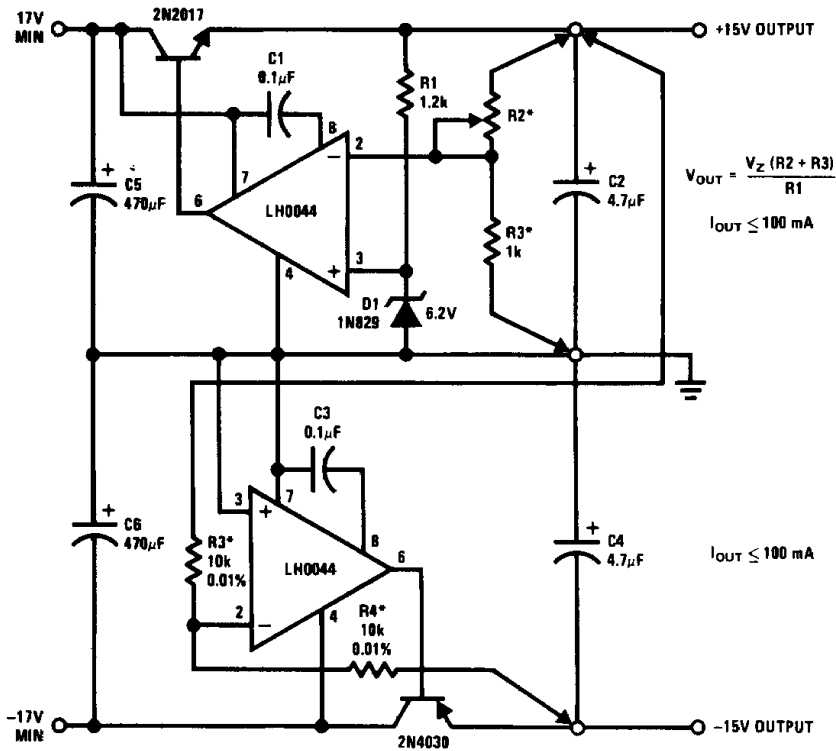

$V_{OUT} = \frac{V_Z (R_2 + R_3)}{R_1}$
 $I_{OUT} \leq 100$ mA

$I_{OUT} \leq 100$ mA

*Wire-wound for minimum drift.
 Line and load regulation $\leq 0.005\%$

TL/K/5551-8

Typical Applications (Continued)

10V Reference Supply

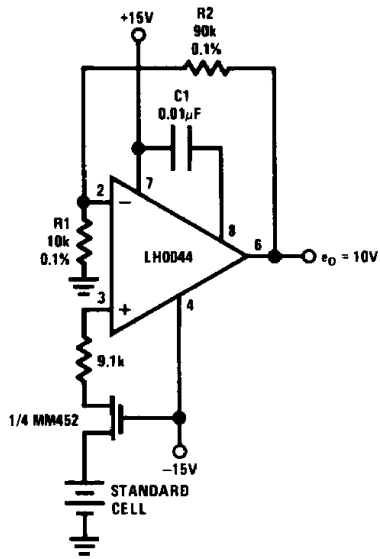

TL/K/5551-9

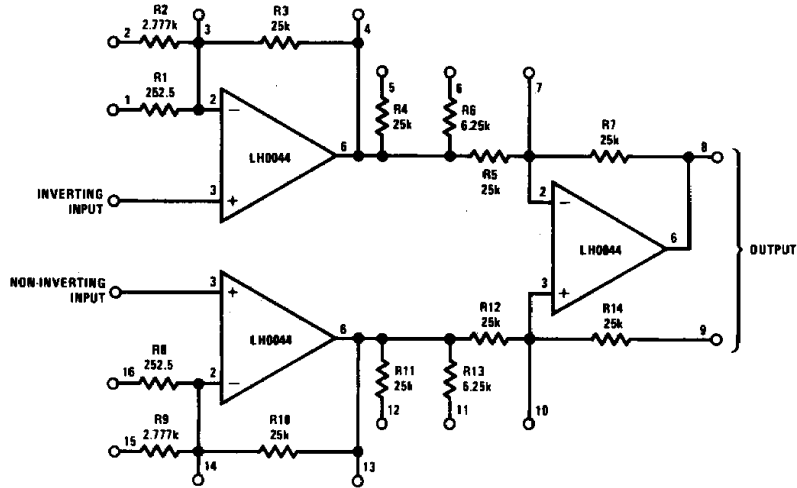

TL/K/5551-10

Precision Instrumentation Amplifier

Overall Gain	Input Stage Gain	Output Stage Gain
X1	X1	X1
X2	X1	X2
X5	X1	X5
X10	X10	X1
X20	X10	X2
X50	X10	X5
X100	X100	X1
X200	X100	X2
X500	X100	X5
X995	X199	X5

Noise Test Circuit

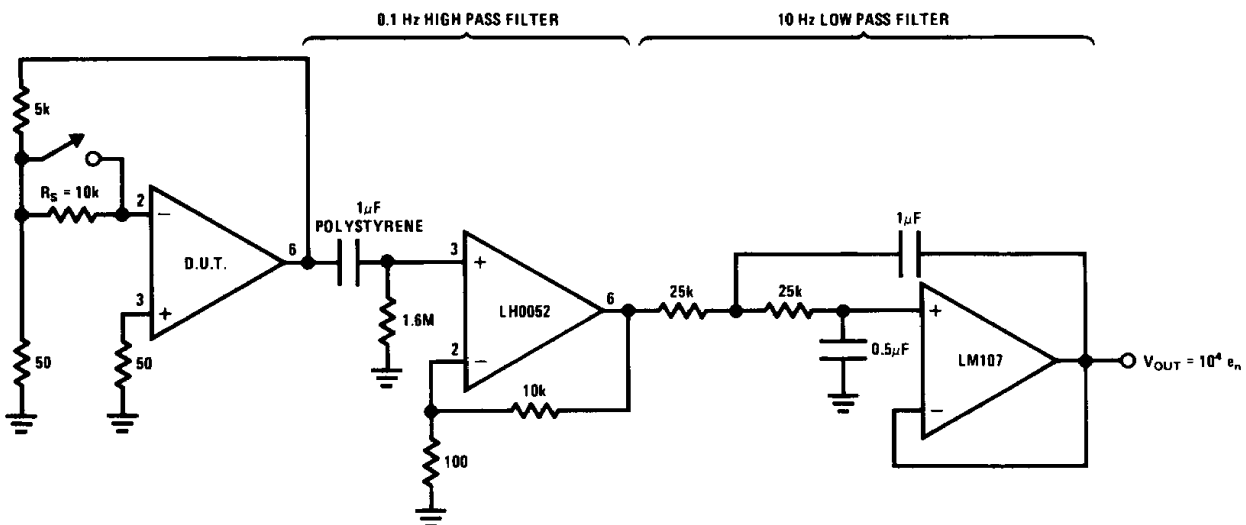

TL/K/5551-11

Noise Test Circuit (Continued)

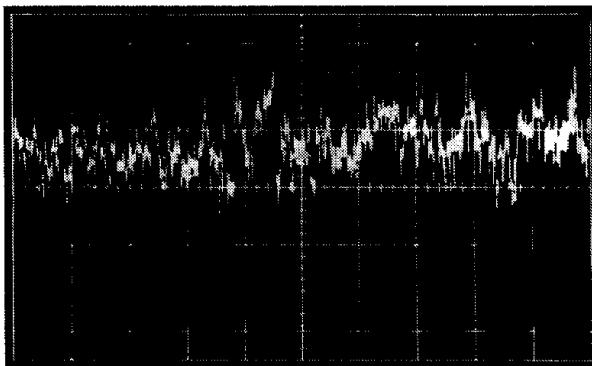

VERT: 200 nV/DIV
HORIZ: 5 SEC/DIV

TL/K/5551-12

Connection Diagram

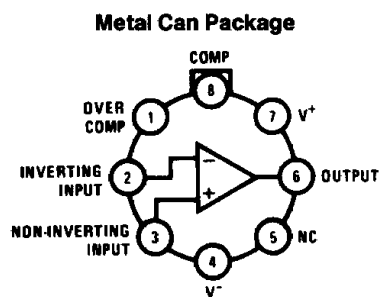

TL/K/5551-2

Top View

Case is electrically isolated

Note: Compensation is not normally required. However, for maximum stability, a $0.01\mu\text{F}$ capacitor should be placed between pins 7 and 8 when device is used below closed loop gains of 10.

**Order Number LH0044H, LH0044CH,
LH0044ACH or LH0044BH
See NS Package Number H08B**