

Epson Stylus® CX3800 Series



Quick Guide

Basic Copying, Printing, and Scanning
Maintaining Your Epson Stylus CX3800 Series
Solving Problems

Contents

Loading Paper	5
Copying a Photo or Document	7
Placing the Original on the Glass	7
Copying	8
Copying a Letter-size Document	8
Copying a Photo	8
Speeding Up Printing	9
Printing From Your Computer	10
Printing in Windows	10
Using Special Papers	13
Scanning a Photo or Document	14
Basic Scanning	15
Restoring Color in Faded Photos	17
Maintaining Your Epson Stylus CX3800 Series	18
Checking the Print Head Nozzles and Ink	18
Cleaning the Print Head	19
Replacing Ink Cartridges	20
Solving Problems	25
Error Indicators	25
Problems and Solutions	26
Copying Problems	26
Paper Feeding Problems	26
Print Quality Problems	27
Where To Get Help	28

Notices	29
Important Safety Instructions	29
Ink Cartridge Safety Instructions	30
ENERGY STAR Compliance	31
FCC Compliance Statement	31
Declaration of Conformity	32
Epson America, Inc., Limited Warranty	33
Copyright Notice	35

Introduction

After you have set up your Epson Stylus® CX3800 Series all-in-one as described on the *Start Here* sheet, turn here to:

- Load paper
- Make a quick copy of a document or photo
- Get the basic steps for printing from your computer
- Start scanning a document or photo
- Perform routine maintenance
- Solve simple problems

This book tells you how to do most of these things without ever turning on your computer! Of course your Epson Stylus CX can do lots more when you connect it to your Windows® computer—such as improving the color and quality of your prints and scanned images, or producing double-sided documents.

For complete instructions on everything your Epson Stylus CX can do, see the on-screen *User's Guide*. An icon for the manual was automatically placed on your desktop when you installed the software.

Please follow these guidelines as you read your Epson Stylus CX3800 Series instructions:

Warning:

Warnings must be followed carefully to avoid bodily injury.

Caution:

Cautions must be observed to avoid damage to your equipment.

Note:

Notes contain important information about your Epson Stylus CX.

Tip:

Tips contain hints for better copying, scanning, and printing.

Loading Paper

Follow the steps here to load paper in your Epson Stylus CX.

1. Open the paper support and output tray, then slide out the extensions.
2. Flip the feeder guard forward. Then slide the left edge guide to the left.

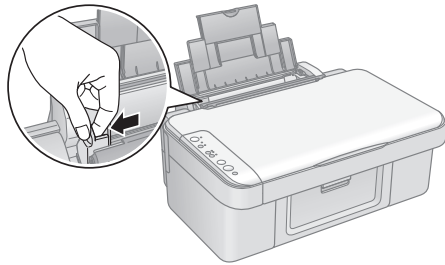
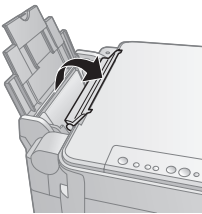
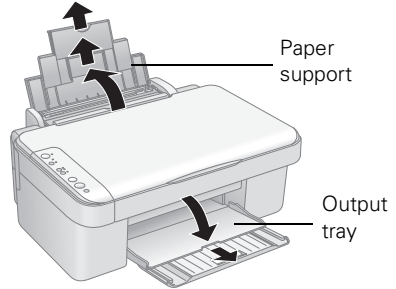

3. Insert the paper, printable side up, against the right edge guide. Always load it short edge first, even for landscape printing.

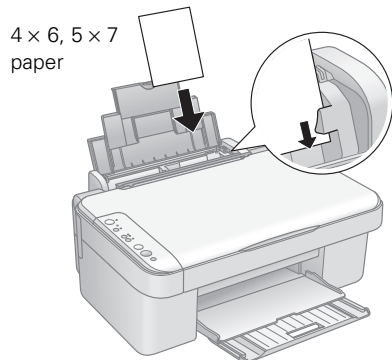
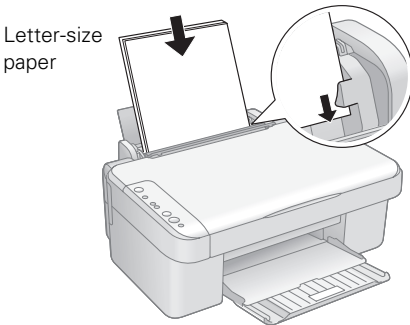

Place paper beneath the tabs.
The paper's printable side is often whiter or brighter than the other side.

You can load up to 100 sheets of plain paper and up to 20 sheets of photo paper. (See the *User's Guide* for capacity guidelines on other paper types.)

Note:

The type of paper you choose affects the way your printout looks, so be sure to select the correct paper for your job. If you are just making a copy or printing a rough draft of an image, plain paper is fine. However, for the best results, you'll want to use one of Epson's special ink jet papers designed for your printer. For example, your photos will look great printed on Epson Premium Glossy Photo Paper. See page 13 for more information.

4. Slide the left edge guide against the left edge of the paper (but not too tightly).

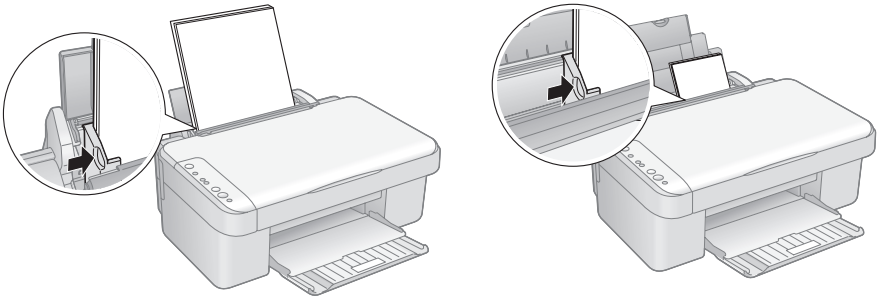

5. Flip the feeder guard back.



Copying a Photo or Document

Follow the instructions in this section to:

- Position your photo or document correctly on the glass (see below)
- Make copies of a photo or document (on page 8)

Placing the Original on the Glass

1. Open the document cover and place your original face-down on the glass, in the upper left corner. Move your original about 0.04 inch (1 mm) away from the top and left edges so all of it will be copied.

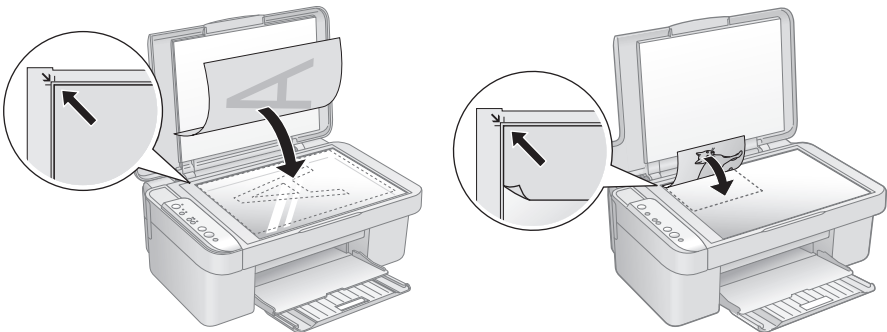

Move the original about 0.04 inch (1 mm) away from the top and left edges to avoid cropping

2. Close the cover gently so you don't move the original.

Caution:

Never open the document cover beyond where it stops and do not place heavy objects on top of the Epson Stylus CX.

Copying

You can make copies using letter-size (8.5×11-inch) paper as described below.

Copying a Letter-size Document

1. Make sure the Epson Stylus CX is turned on.
2. Place the document on the glass as described on page 7. Be sure to close the document cover.
3. Load letter-size paper. (See page 5 for instructions.)
4. Press the paper size button to select **Letter**.
5. If you want your copies automatically reduced or enlarged to fit the loaded paper size, press the **Fit to Page** button.
6. To make a color copy, press the **Start Color** button.



To make a black and white copy, press the **Start B&W** button.

The **On** light flashes and after a moment the Epson Stylus CX starts printing.

If you need to stop copying at any time, just press the **Stop** button. Do not pull out paper that is being printed; it will be ejected automatically to the output tray.

Note:

The copies may not be exactly the same size as the original.

Copying a Photo

1. Make sure the Epson Stylus CX is turned on.
2. Place the photo on the glass as described on page 7. Be sure to close the document cover.



3. Load up to 20 sheets of 4 × 6-inch or letter-size (8.5 × 11-inch) photo paper. (See page 5 if you need instructions.)
4. Press the paper size button to select 4"×6" or Letter.
5. If you want your photos printed without a white border, press the **Fit to Page** button. (Otherwise, they are printed with a 0.06-inch [1.5 mm] margin.)
6. To make a color copy, press the **Start Color** button.
To make a black and white copy, press the **Start B&W** button.

The **On** light flashes and after a moment the Epson Stylus CX starts printing.

If you need to stop copying at any time, just press the **Stop** button. Do not pull out paper that is being printed; it will be ejected automatically to the output tray.

Note:

The copies may not be exactly the same size as the original.

Speeding Up Printing

If you want to make a copy quickly and do not need high quality, you can print a “draft” copy. The print quality is reduced, but the copy is printed faster.

When you are ready to copy, press and hold down the **Stop** button, then press the **Start Color** button (to copy in color) or the **Start B&W** button (to copy in black and white). When the **On** light starts flashing, release both buttons.



Printing From Your Computer

This section describes the basic steps for printing a photo or document stored on your Windows computer.

Note:

For detailed instructions on printing, see the on-screen *User's Guide*.

Before you start, make sure you've installed your printer software and connected the Epson Stylus CX3800 Series to your computer as described on the *Start Here* sheet. Also be sure to use the right paper and select the correct paper type setting in the printer driver. (See page 13 for more information.)

Follow the instructions in these sections:

- “Printing in Windows” (below)
- “Using Special Papers” on page 13

Printing in Windows

1. Load paper (see page 5).
2. Open the photo or document in your application program.
3. Open the File menu and select **Print**. You see a window like this one:

Select EPSON Stylus CX3800 Series

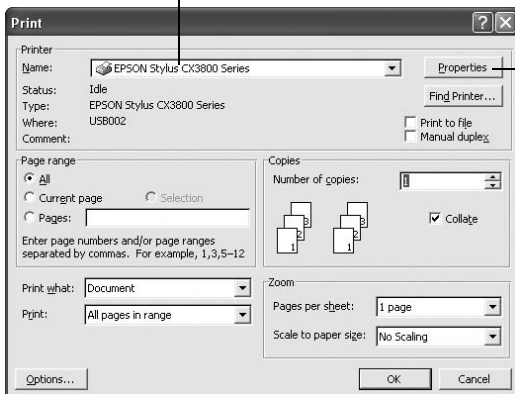

Click here to open your printer software

4. Make sure **EPSON Stylus CX3800 Series** is selected, then click the **Preferences** or **Properties** button.

(If you see a **Setup**, **Printer**, or **Options** button, click it. Then click **Preferences** or **Properties** on the next screen.)

5. On the **Main** tab, select the basic print settings:

Select the type of document you're printing
(choose **Photo** or **Best Photo** for pictures)

The screenshot shows the 'EPSON Stylus CX3800 Series Properties' dialog box. It has three tabs: 'Main', 'Page Layout', and 'Maintenance'. The 'Main' tab is active. Under 'Quality Option', there are five icons: Draft, Text (selected), Text & Image, Photo, and Best Photo. Below this is the 'Paper Options' section with a 'Borderless' checkbox, a 'Type' dropdown set to 'Plain Paper / Bright White Paper', and a 'Size' dropdown set to 'Letter (8 1/2 x 11 in)'. To the right is the 'Print Options' section with checkboxes for 'PhotoEPhance', 'Reverse Order', and 'Print Preview'. At the bottom left is the 'Ink Levels' section with four vertical bars. At the bottom right is the 'Orientation' section with radio buttons for 'Portrait' (selected) and 'Landscape'. There is also a printer icon. At the very bottom are 'Reset Defaults', 'Online Support', 'Show Settings', 'Advanced', 'OK', 'Cancel', and 'Help' buttons. Annotations with arrows point to various elements: 'Select your paper Type' points to the Quality Option icons; 'Select your paper Size' points to the Paper Options dropdowns; 'Click here for borderless photos, after choosing paper Type' points to the Borderless checkbox; 'Select your document Orientation' points to the Orientation radio buttons; and 'Click here for more options' points to the Advanced button.

Select your paper Type

Select your paper Size

Click here for borderless photos, after choosing paper Type

Select your document Orientation

Click here for more options

Make sure you choose the correct paper **Type** setting for the paper you are using. See page 13 for details.

Note:

For more information about print settings, click the **?** or **Help** button.

- For more printing options, click the **Advanced** button. Then select the following settings as necessary:

Select a color management method
(To choose **No Color Adjustment**, click **ICM** first)

Select **Paper & Quality Options** as necessary

Click here to select **Photo RPM** for the best print quality on certain paper types

Select **Print Options** as necessary

Click here if you want to see this Advanced screen each time you access your print settings

Note:

For more information about advanced settings, or instructions on saving them as a group so you can reuse them later, click **?** or **Help**.

- If you want to change the layout settings, click the **Page Layout** tab and select settings as necessary.
- Click **OK** to save your settings, then click **OK** or **Print** to start printing. This window appears and shows the progress of your print job.

Cancel printing

Pause or resume printing

Check remaining ink levels

Using Special Papers

You can purchase genuine Epson ink and paper from an authorized Epson reseller. To find the nearest reseller, please call 800-GO-EPSON (800-463-7766). To purchase online, visit www.epsonstore.com (U.S. sales only). In Canada, please call (800) 463-7766 for reseller referral.

Paper name	Size	Part number
Epson Ultra Premium Glossy Photo Paper	Borderless 4 × 6 inches	S041934
	Letter (8.5 × 11 inches)	S041935
Epson Premium Glossy Photo Paper	Borderless 4 × 6 inches	S041808/S041727
	Borderless 5 × 7 inches	S041464
	Borderless 8 × 10 inches	S041465
	Letter (8.5 × 11 inches)	S041286/S041667
Epson Premium Semigloss Photo Paper	Letter (8.5 × 11 inches)	S041331
Epson Glossy Photo Paper	Borderless 4 × 6 inches	S041809
	Letter (8.5 × 11 inches)	S041141/S041649/ S041272/S041271
Epson Photo Quality Ink Jet Paper	Letter (8.5 × 11 inches)	S041062
	Legal (8.5 × 14 inches)	S041067
	A4 (8.3 × 11.7 inches)	S041061
Epson Premium Bright White Paper	Letter (8.5 × 11 inches)	S041586
Epson Matte Paper Heavyweight	Borderless 8 × 10 inches	S041467
	Letter (8.5 × 11 inches)	S041257
Epson Double-Sided Matte Paper	Letter (8.5 × 11 inches)	S041568

Be sure to select the correct **Type** or **Media Type** setting in your printer software:

For this paper	Select this setting
Epson Ultra Premium Glossy Photo Paper	Ultra Premium Glossy Photo Paper
Epson Premium Glossy Photo Paper	Premium Glossy Photo Paper
Epson Premium Semigloss Photo Paper	Premium Semigloss Photo Paper
Epson Glossy Photo Paper	Glossy Photo Paper
Epson Matte Paper Heavyweight Epson Double-Sided Matte Paper Epson Photo Quality Ink Jet Paper	Matte Paper - Heavyweight
Plain paper Epson Premium Bright White Paper	Plain Paper/Bright White Paper
Envelopes	Envelope

Scanning a Photo or Document

You can use your Epson Stylus CX3800 Series to scan a photo or document and save it on your computer or other device, or to fax or e-mail it to someone else.

You can even automatically restore faded color photographs as you scan. See page 17 for details.

The Epson Scan software provides three scanning modes for progressive levels of control over your scanned image:

- **Full Auto Mode** scans quickly and easily using automatic settings.
- **Home Mode** previews your image and provides automatic image adjustments, cropping tools, and preset options for various types of scans.
- **Professional Mode** previews your image and lets you manually configure your scan settings with a full array of tools.

Basic Scanning

You can scan from any TWAIN-compliant application—such as ArcSoft PhotoImpression™—using Epson Scan. Or you can start Epson Scan directly from your computer and save your image to a file.

1. Open the document cover and place your original face-down on the glass, in the upper left corner. Move your original about 0.04 inch (1 mm) away from the top and left edges so all of it will be scanned.

Move the original about 0.04 inch (1 mm) away from the top and left edges to avoid cropping

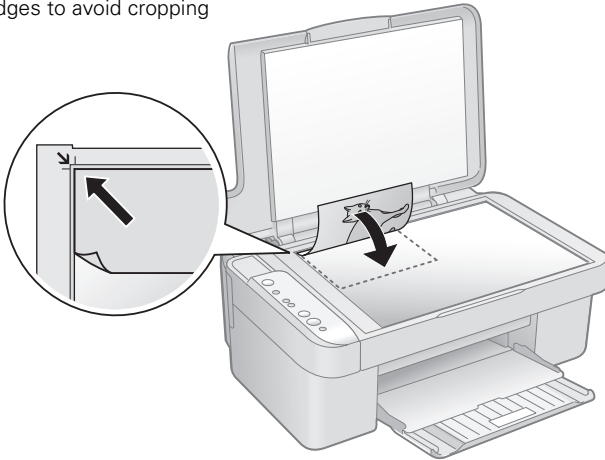

2. Close the cover gently so you don't move the original.
3. Do one of the following to start Epson Scan:
 - Double-click the **Epson Scan** icon on your desktop.
 - If you are scanning from an application, start your application. Then open the File menu, choose **Import** or **Acquire**, and select **EPSON Stylus CX3800 Series**.

You see the Epson Scan standby window:

4. If the Mode setting in the upper right corner is set to **Full Auto Mode**, click the **Scan** button.

Note:

If you want to automatically restore a color photo as you scan, click the **Customize** button and see page 17 for instructions.

(If you are in Home or Professional Mode, you see a different Epson Scan settings window. You can change the mode using the Mode selector in the upper right corner. For details, see the on-screen *User's Guide*.)

5. You see the File Save Settings window:

Choose the location where you want to save your scanned file and type a name for it in the Prefix box. Select a file format in the Image Format box.

6. Click **OK**. The image is scanned and you see its icon in an open folder.

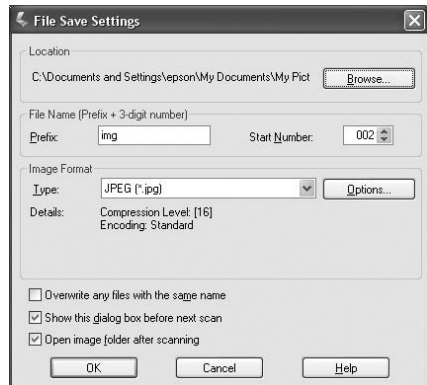
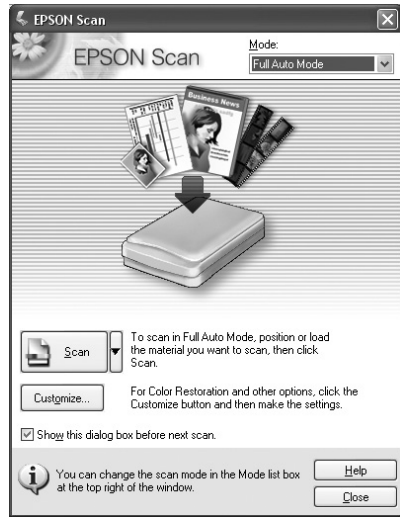

Restoring Color in Faded Photos

You can automatically transform an old, faded, or badly exposed color photo into one with true-to-life color and sharpness as you scan. Look for the **Color Restoration** option in Epson Scan's Full Auto, Home, and Professional Mode windows:

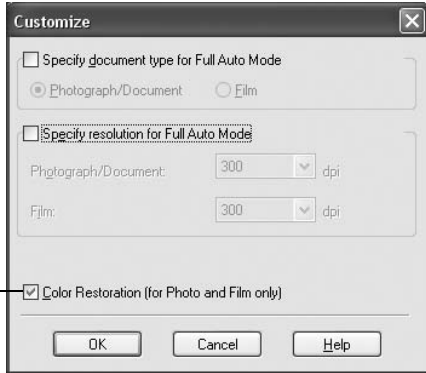

Full Auto Mode

Click the **Customize** button, click the **Color Restoration** button, click **OK**, and click **Scan**.



Home Mode

Preview your image, click the **Color Restoration** button, and click **Scan**.

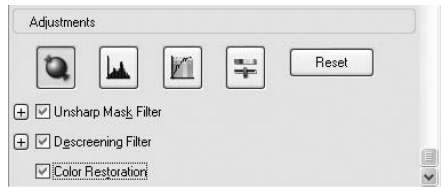

Professional Mode

Preview your image, scroll down to the **Adjustments** area, click the **Color Restoration** button, and click **Scan**.

Note:

For details on using Home or Professional Mode, or for more information about Full Auto Mode settings, see the on-screen *User's Guide*. You can also click **Help** on the Epson Scan screen for information about all the available settings.



Maintaining Your Epson Stylus CX

If you notice a decline in print quality, follow the instructions in this chapter for:

- “Checking the Print Head Nozzles and Ink” (below)
- “Cleaning the Print Head” on page 19
- “Replacing Ink Cartridges” on page 20

Checking the Print Head Nozzles and Ink

If your printouts are faint or have gaps in them, some of the nozzles in the print head may be clogged or ink may be running low in one or more of the ink cartridges. Follow the steps below to check the print head nozzles and remaining ink levels using the control panel.

1. Turn off the Epson Stylus CX all-in-one.
2. Load letter-size paper in the sheet feeder.
3. Press the  Ink and  On buttons together and hold them down for about 3 seconds. The Epson Stylus CX turns on and prints a test pattern. It also shows the percentage of ink left in each cartridge:



Print head does not need to be cleaned yet

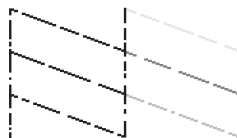

Print head needs to be cleaned

If the pattern does not look good, try cleaning the print head as described on the next page.

Note:

You can also check the ink level using Status Monitor 3; see the on-screen *User's Guide*.





Cleaning the Print Head

If your printouts are unexpectedly light or faint, or you notice light or dark bands across your printout, you may need to clean the print head. This unclogs the nozzles so they can deliver ink properly. Run a nozzle check as described on page 18 to see if the print head needs cleaning.

Note:

Print head cleaning uses ink, so clean it only if quality declines and the nozzle check indicates that the print head needs to be cleaned.

If the red  ink light comes on or flashes, you cannot clean the print head. In this case, replace the appropriate ink cartridge first; see page 20.

1. Make sure the Epson Stylus CX is on and the  ink light is off.
2. Hold down the  ink button for 3 seconds until the  On light starts flashing. The Epson Stylus CX runs a head cleaning cycle and the  On light flashes.

Caution:

Never turn off the Epson Stylus CX while head cleaning is in progress. You may damage it.

3. When the  On light stops flashing, run a nozzle check (as described on page 18) to verify that the print head is clean.
4. If there are still gaps or lines, or the test patterns are faint, run another cleaning cycle and check the nozzles again.

Note:



If you don't see any improvement after cleaning the print head four or five times, turn off the Epson Stylus CX and wait overnight. This lets any dried ink soften.

Then try cleaning the print head again. If quality still does not improve, one of the ink cartridges may be old or damaged and needs to be replaced; see page 20.

Tip:

If you do not use your Epson Stylus CX often, it is a good idea to print a few pages at least once a month to maintain good print quality.

Replacing Ink Cartridges

When the red  ink light starts flashing, one or more cartridges are low on ink. When the red  ink light stays on, you need to replace the cartridge(s). You'll also see a message on your screen when you print, telling you which cartridge is low or empty.

You can purchase genuine Epson ink and paper from an authorized Epson reseller. To find the nearest reseller, please call 800-GO-EPSON (800-463-7766). To purchase online, visit www.epsonstore.com (U.S. sales only). In Canada, please call (800) 463-7766 for reseller referral. Use these part numbers when you order or purchase new ink cartridges.

Color	Part number
Black	T060120
Cyan	T060220
Magenta	T060320
Yellow	T060420

Caution:

Leave the empty cartridge installed until you have obtained a replacement, or the ink remaining in the print head nozzles may dry out. To ensure good results, use genuine Epson ink cartridges and do not refill them. Other products may cause damage to your Epson Stylus CX not covered by Epson's warranty.

Note:





We recommend that you use genuine Epson cartridges. The use of other products may affect your print quality and could result in printer damage. See www.epson.com for more cartridge information. Yields vary considerably based on images printed, print settings, paper type, frequency of use, and temperature. The printer ships with full ink cartridges and part of the ink from the first cartridges is used for priming the printer.

1. Make sure the Epson Stylus CX is on.
2. Make sure that the document cover is closed, then open the scanner.

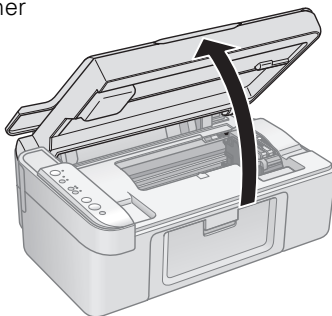
Caution:

Do not open the scanner when the document cover is open.



3. Press and release the  ink button. The ink cartridge holder moves to the check position and the  On and  ink lights flash. If one of the cartridges is low or empty, the Epson Stylus CX moves that cartridge to the  ink out mark.

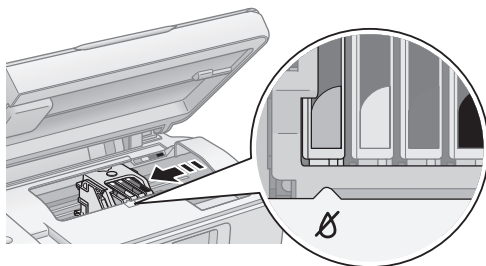



Note:

Don't hold down the  ink button for more than 3 seconds, or the printer will start to clean the print head.

Caution:

Don't move the print head by hand; this may damage the Epson Stylus CX. Always press the  ink button to move the print head.

4. Press the  ink button again.
 - If more than one cartridge is empty or low, the next cartridge moves to the  ink out mark.
 - If all of the empty or low ink cartridges have been identified, the print head moves to the ink cartridge replacement position.

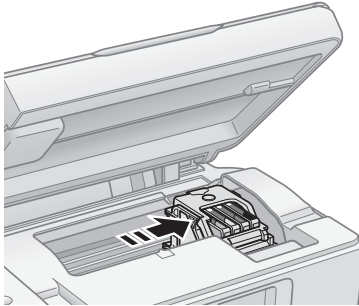

5. Open the cartridge cover and squeeze the tab at the back of the empty/low cartridge and lift it straight out. Dispose of it carefully. Do not take the used cartridge apart or try to refill it.

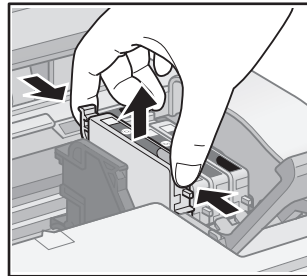
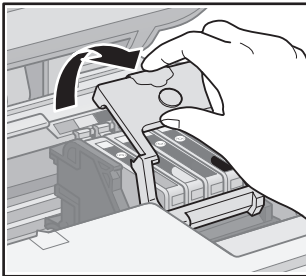

Warning:

If ink gets on your hands, wash them thoroughly with soap and water. If ink gets into your eyes, flush them immediately with water.

- Before you open the new ink cartridge package, shake it four or five times. Then remove it from the package.

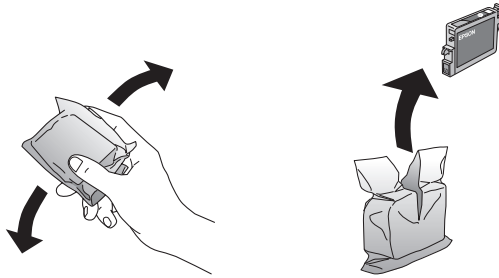

Caution:

Do not remove or tear the label on the cartridge; otherwise, ink will leak.

Do not touch the green chip on the side of the cartridge. This can damage the ink cartridge.

- Place the new ink cartridge into the cartridge holder and push it down until it clicks into place.

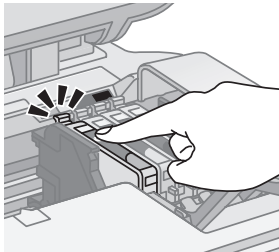
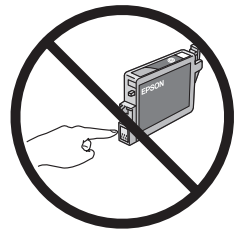



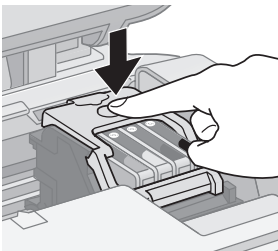

- Replace any other cartridges that need to be replaced.
- Close the ink cartridge cover and press it until it clicks into place.

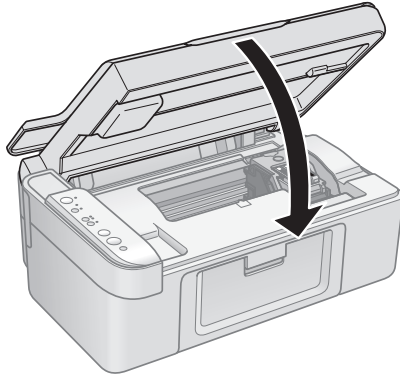

10. Close the scanner.



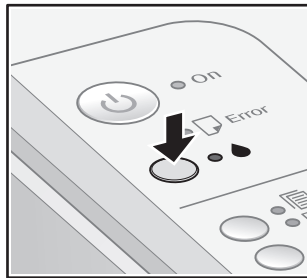

11. Press the  ink button. The Epson Stylus CX begins charging ink and the  On light starts flashing. This takes about one minute. When it's finished, the  On light stops flashing and remains on, and the  ink light goes out.



Caution:

Never turn off the Epson Stylus CX while the  On light is flashing or you'll waste ink.

Note:

If the  ink light stays on (not flashing), the ink cartridge may not be installed correctly. Press the  ink button again and reinstall the ink cartridge until it clicks into place.

Solving Problems

If you have a problem with your Epson Stylus CX3800 Series all-in-one, check the lights on the control panel to diagnose what may be causing it.

You can also check “Problems and Solutions” on page 26 for basic troubleshooting suggestions, or double-click the *User’s Guide* icon on your computer desktop for more detailed help.

See these sections:

- “Error Indicators” (below)
- “Problems and Solutions” on page 26
- “Where To Get Help” on page 28



Error Indicators

Light: status	Cause	Solution
□ Error: On	No paper is loaded in the sheet feeder.	Load paper in the sheet feeder (see page 5). Then press Start Color to continue or Stop to cancel.
	Multiple pages have been fed into the sheet feeder.	Remove and reload the paper (see page 5). Then press Start Color to continue or Stop to cancel.
□ Error: Flashing	Paper is jammed.	See page 26.
◆ Ink: Flashing	An ink cartridge is running low on ink.	See “Replacing Ink Cartridges” on page 20.
◆ Ink: On	An ink cartridge is empty or not installed correctly.	See “Replacing Ink Cartridges” on page 20.
All lights: Flashing	There is a problem with the Epson Stylus CX.	Turn the Epson Stylus CX off and then back on. If the error does not clear, contact your local authorized servicer or contact Epson; see page 28.

Problems and Solutions

Check the solutions below if you're having trouble using your Epson Stylus CX.



Note:

When you turn off the Epson Stylus CX, a red light inside it may stay on for up to 15 minutes. This is normal.

Copying Problems

- Make sure your original is positioned in the top left corner of the glass. Place it 0.04 inch (1 mm) from the edges to avoid cropping.
- Make sure your paper is loaded short edge first and is positioned against the right edge guide with the left edge guide against its left side. Don't load paper above the arrow mark inside the left edge guide.

Paper Feeding Problems

- If paper doesn't feed, remove it from the sheet feeder. Flip through the stack to separate the sheets a little. Then reload the paper against the right edge guide, and slide the left edge guide against the paper (but not too tightly). Make sure the paper is not in front of the feeder guard.
- Do not load too many sheets at once (up to 20 sheets of photo paper and 100 sheets of plain paper). See the *User's Guide* for more information.
- If paper is jammed, the red  **Error** light flashes. Follow these steps to clear the jam:
 1. Press the  **Start Color** button to eject the jammed paper. If the jammed paper is not ejected, go to the next step.
 2. If the paper is stuck near the sheet feeder or output tray, gently pull it out.

If the paper is stuck inside the Epson Stylus CX, press the  **On** button to turn it off. Open the scanner and remove any paper inside, including any torn pieces. Do not pull it backward however; this can damage the sheet feeder. Close the scanner, then turn the Epson Stylus CX back on.

Print Quality Problems

If you have any problems with the copy or print quality, try these solutions:

- Make sure the document is placed flat against the document table glass and the Epson Stylus CX is not tilted or placed on an uneven surface.
- Load the paper printable side up (usually the whiter, brighter, or glossy side).
- Make sure your paper isn't damp or curled.
- Use a support sheet with special paper or load your paper one sheet at a time. Remove sheets from the output tray so not too many collect at a time.
- Make sure the type of paper you loaded matches the paper size and paper type settings on the control panel or in your printer software (see page 13).
- For the best print quality, use Epson special paper (see page 13) and genuine Epson ink cartridges (see page 20).
- If you notice light or dark bands across your printouts or they are too faint, you may need to clean the print head. This unclogs the nozzles so they can deliver ink properly. Run a nozzle check as described on page 18 to see if the print head needs cleaning.
- Clean the print head as described on page 19.
- If you notice jagged vertical lines, you may need to align the print head. See your *User's Guide* for instructions.
- The ink cartridges may be old or low on ink; see page 20 for instructions on replacing an ink cartridge.
- If a dotted line appears in the image, clean the scanner glass with a soft, dry, lint-free cloth (paper towels are not recommended), or use a small amount of glass cleaner on a soft cloth, if necessary. **Don't spray glass cleaner directly on the glass.**

Where To Get Help

Epson provides technical assistance 24 hours a day through the electronic support services and automated telephone services listed in the following table.

Service	Access
World Wide Web	From the Internet, you can reach Epson Support at http://support.epson.com . At this site, you can download drivers and other files, look at product documentation, access troubleshooting information, and receive technical advice through e-mail.
Automated Telephone Services	A variety of automated help services are available 24 hours a day, seven days a week. To use these services, you must have a touch tone telephone and call (800) 922-8911 . Your Epson SoundAdvice SM Express Code is 70665 . Use this code to quickly select the Epson Stylus CX3800 Series in SoundAdvice.

To speak to a technical support representative, dial:

- U.S.: (562) 276-4382, 6 AM to 6 PM, Pacific Time, Monday through Friday
- Canada: (905) 709-3839, 6 AM to 6 PM, Pacific Time, Monday through Friday

Toll or long distance charges may apply. Before you call, please have the following information ready:

- Product name (Epson Stylus CX3800 Series all-in-one)
- Product serial number (located on the back)
- Proof of purchase (such as a store receipt) and date of purchase
- Computer configuration
- Description of the problem

You can purchase genuine Epson ink and paper from an authorized Epson reseller. To find the nearest reseller, please call 800-GO-EPSON (800-463-7766). To purchase online, visit www.epsonstore.com (U.S. sales only). In Canada, please call (800) 463-7766 for reseller referral.

Other Software Technical Support:

Software	Telephone/Fax	Online and E-mail
ArcSoft PhotoImpression	(510) 440-9901 8:30 AM—5:30 PM, Pacific Time, Monday—Friday Fax: (510) 440-1270	www.arcsoft.com support@arcsoft.com

Notices

Important Safety Instructions

Before using your Epson Stylus CX3800 Series all-in-one, read and follow these safety instructions:

- Be sure to follow all warnings and instructions marked on the Epson Stylus CX.
- Use only the type of power source indicated on the Epson Stylus CX label.
- Use only the power cord that comes with the Epson Stylus CX. Use of another cord may cause fires or shock. Do not use the cord with any other equipment.
- Place the Epson Stylus CX near a wall outlet where the plug can be easily unplugged. *Placez l'imprimante près d'une prise de contact où la fiche peut être débranchée facilement.*
- Do not let the power cord become damaged or frayed.
- If you use an extension cord with the Epson Stylus CX, make sure the total ampere rating of the devices plugged into the extension cord does not exceed the cord's ampere rating. Also, make sure the total ampere rating of all devices plugged into the wall outlet does not exceed the wall outlet's ampere rating.
- Avoid locations that are subject to rapid changes in heat or humidity, shocks or vibrations, or dust.
- Leave enough room around the Epson Stylus CX for sufficient ventilation. Do not block or cover openings in the Epson Stylus CX case or insert objects through the slots.
- Do not place the Epson Stylus CX near a radiator or heating vent or in direct sunlight.
- Place the Epson Stylus CX on a flat, stable surface that extends beyond its base in all directions. It will not operate properly if it is tilted or at an angle.
- Make sure the back of the Epson Stylus CX is at least 3.9 inches (10 cm) away from the wall.
- Do not open the scanner section while the Epson Stylus CX is copying, printing, or scanning.
- Do not spill liquid on the Epson Stylus CX.
- Except as specifically explained in your documentation, do not attempt to service the Epson Stylus CX yourself.

- Unplug the Epson Stylus CX and refer servicing to qualified service personnel under the following conditions: if the power cord or plug is damaged; if liquid has entered the product; if the product has been dropped or the case damaged; if the product does not operate normally or exhibits a distinct change in performance. Adjust only those controls that are covered by the operating instructions.
- When storing or transporting the Epson Stylus CX, do not tilt it, stand it on its side, or turn it upside down; otherwise ink may leak from the cartridge.
- The lamp in this product contains mercury. Dispose of it according to local, state, or federal laws.

Ink Cartridge Safety Instructions

- Keep ink cartridges out of the reach of children and do not drink the ink.
- Be careful when you handle used ink cartridges; there may be ink remaining around the ink supply port. If ink gets on your skin, wash it off with soap and water. If it gets in your eyes, flush them immediately with water.
- Do not put your hand inside the Epson Stylus CX or touch any cartridges during printing.
- Install a new ink cartridge immediately after removing an empty one. Leaving cartridges uninstalled can dehydrate the print head and may prevent the Epson Stylus CX from printing.
- If you remove an ink cartridge for later use, protect the ink supply area from dirt and dust and store it in the same environment as the Epson Stylus CX. Note that there is a valve in the ink supply port, making covers or plugs unnecessary, but care is needed to prevent the ink from staining items that the cartridge touches. Do not touch the ink cartridge ink supply port or surrounding area.

ENERGY STAR Compliance

As an ENERGY STAR® Partner, Epson has determined that this product meets the ENERGY STAR guidelines for energy efficiency. The EPA ENERGY STAR office equipment program is a voluntary partnership with the computer and office equipment industry to promote the introduction of energy-efficient personal computers, monitors, printers, fax machines, and copiers in an effort to reduce air pollution caused by power generation.



FCC Compliance Statement

For United States Users

This equipment has been tested and found to comply with the limits for a Class B digital device, pursuant to Part 15 of the FCC Rules. These limits are designed to provide reasonable protection against harmful interference in a residential installation. This equipment generates, uses, and can radiate radio frequency energy and, if not installed and used in accordance with the instructions, may cause harmful interference to radio or television reception. However, there is no guarantee that interference will not occur in a particular installation. If this equipment does cause interference to radio and television reception, which can be determined by turning the equipment off and on, the user is encouraged to try to correct the interference by one or more of the following measures:

- Reorient or relocate the receiving antenna.
- Increase the separation between the equipment and receiver.
- Connect the equipment into an outlet on a circuit different from that to which the receiver is connected.
- Consult the dealer or an experienced radio/TV technician for help.

WARNING

The connection of a non-shielded equipment interface cable to this equipment will invalidate the FCC Certification of this device and may cause interference levels which exceed the limits established by the FCC for this equipment. It is the responsibility of the user to obtain and use a shielded equipment interface cable with this device. If this equipment has more than one interface connector, do not leave cables connected to unused interfaces. Changes or modifications not expressly approved by the manufacturer could void the user's authority to operate the equipment.

For Canadian Users

This Class B digital apparatus complies with Canadian ICES-003.

Cet appareil numérique de la classe B est conforme à la norme NMB-003 du Canada.

Declaration of Conformity

According to 47CFR, Part 2 and 15 for: Class B Personal Computers and Peripherals; and/or CPU Boards and Power Supplies used with Class B Personal Computers:

We: Epson America, Inc.
Located at: MS 3-13
3840 Kilroy Airport Way
Long Beach, CA 90806
Telephone: (562) 290-5254

Declare under sole responsibility that the product identified herein, complies with 47CFR Part 2 and 15 of the FCC rules as a Class B digital device. Each product marketed is identical to the representative unit tested and found to be compliant with the standards. Records maintained continue to reflect the equipment being produced can be expected to be within the variation accepted, due to quantity production and testing on a statistical basis as required by 47CFR §2.909. Operation is subject to the following two conditions: (1) this device may not cause harmful interference, and (2) this device must accept any interference received, including interference that may cause undesired operation.

Trade Name: Epson
Type of Product: Multifunction printer
Model: C241A

Epson America, Inc., Limited Warranty

What Is Covered: Epson America, Inc. (“Epson”) warrants to the original retail purchaser that the Epson printer covered by this limited warranty statement, if purchased and operated only in the United States or Canada, conforms to the manufacturer’s specifications and will be free from defects in workmanship and materials for a period of one (1) year from the date of original purchase. Epson also warrants that the consumable ink cartridges enclosed with the printer will perform to the manufacturer’s specified usage, which usage may expire before the expiration of the limited warranty for the Epson printer. For warranty service, you must provide proof of the date of original purchase.

What Epson Will Do To Correct Problems: Should your Epson printer prove defective during the warranty period, please call the Epson ConnectionSM at (562) 276-4382 (U.S.) or (905) 709-3839 (Canada) for warranty repair instructions and return authorization. An Epson service technician will provide telephone diagnostic service to determine whether the printer requires service. If service is needed, Epson will, at its option, exchange or repair the printer without charge for parts or labor. If Epson authorizes an exchange for the defective unit, Epson will ship a replacement printer to you, freight prepaid, so long as you use an address in Canada or the U.S. (excluding Puerto Rico and U.S. Possessions). Shipments to other locations will be made freight collect. You are responsible for securely packaging the defective unit and returning it to Epson within five (5) working days of receipt of the replacement. Epson requires a debit or a credit card number to secure the cost of the replacement printer in the event that you fail to return the defective one. If your printer is being repaired, Epson will direct you to send your printer to Epson or its authorized service center, where the printer will be fixed and sent back to you. You are responsible for packing the printer and for all costs to and from the Epson authorized service center. When warranty service involves the exchange of the printer or a part, the item replaced becomes Epson property. The replacement printer or part may be new or refurbished to the Epson standard of quality, and, at Epson’s option, may be another model of like kind and quality. Epson’s liability for replacement of the covered printer will not exceed the original retail selling price of the covered printer. Exchange products and parts assume the remaining warranty period of your original product covered by this limited warranty.

What This Warranty Does Not Cover: This warranty does not apply to refurbished or reconditioned products. This warranty covers only normal use in the United States and Canada. Using this product for continuous production or similar high duty purposes is not considered normal use; damage, maintenance or service from such use will not be covered under this warranty. This warranty is not transferable. This warranty does not cover any color change or fading of prints or reimbursement of materials or services required for reprinting. This warranty does not cover damage to the Epson product caused by parts or supplies not manufactured, distributed or certified by Epson. This warranty does not cover ribbons, ink cartridges or third party parts, components, or peripheral

devices added to the Epson product after its shipment from Epson, e.g., dealer or user-added boards or components. Epson is not responsible for warranty service should the Epson label or logo or the rating label or serial number be removed or should the product fail to be properly maintained or fail to function properly as a result of misuse, abuse, improper installation, neglect, improper shipping, damage caused by disasters such as fire, flood, and lightning, improper electrical current, software problems, interaction with non-Epson products, or service other than by an Epson Authorized Servicer. If a claimed defect cannot be identified or reproduced, you will be held responsible for the costs incurred.

THE WARRANTY AND REMEDY PROVIDED ABOVE ARE EXCLUSIVE AND IN LIEU OF ALL OTHER EXPRESS OR IMPLIED WARRANTIES INCLUDING, BUT NOT LIMITED TO, THE IMPLIED WARRANTIES OF MERCHANTABILITY, NON-INFRINGEMENT OR FITNESS FOR A PARTICULAR PURPOSE. SOME LAWS DO NOT ALLOW THE EXCLUSION OF IMPLIED WARRANTIES. IF THESE LAWS APPLY, THEN ALL EXPRESS AND IMPLIED WARRANTIES ARE LIMITED TO THE WARRANTY PERIOD IDENTIFIED ABOVE. UNLESS STATED HEREIN, ANY STATEMENT OR REPRESENTATIONS MADE BY ANY OTHER PERSON OR FIRM ARE VOID. EXCEPT AS PROVIDED IN THIS WRITTEN WARRANTY, NEITHER EPSON AMERICA, INC. NOR ITS AFFILIATES SHALL BE LIABLE FOR ANY LOSS, INCONVENIENCE, OR DAMAGE, INCLUDING DIRECT, SPECIAL, INCIDENTAL OR CONSEQUENTIAL DAMAGES, RESULTING FROM THE USE OR INABILITY TO USE THE EPSON PRODUCT, WHETHER RESULTING FROM BREACH OF WARRANTY OR ANY OTHER LEGAL THEORY.

In Canada, warranties include both warranties and conditions.

Some jurisdictions do not allow limitations on how long an implied warranty lasts, and some jurisdictions do not allow the exclusion or limitation of incidental or consequential damages, so the above limitations and exclusions may not apply to you. This warranty gives you specific legal rights and you may have other rights which vary from jurisdiction to jurisdiction.

To find the Epson Authorized Reseller nearest you, visit our website at:
<http://www.epson.com>.

To find the Epson Customer Care Center nearest you, visit <http://support.epson.com>.

You can also write to:

Epson America, Inc., P.O. Box 93012, Long Beach, CA 90809-3012

Copyright Notice

All rights reserved. No part of this publication may be reproduced, stored in a retrieval system, or transmitted in any form or by any means, electronic, mechanical, photocopying, recording, or otherwise, without the prior written permission of Seiko Epson Corporation. The information contained herein is designed only for use with this Epson product. Epson is not responsible for any use of this information as applied to other equipment.

Neither Seiko Epson Corporation nor its affiliates shall be liable to the purchaser of this product or third parties for damages, losses, costs, or expenses incurred by purchaser or third parties as a result of: accident, misuse, or abuse of this product or unauthorized modifications, repairs, or alterations to this product, or (excluding the U.S.) failure to strictly comply with Seiko Epson Corporation's operating and maintenance instructions.

Seiko Epson Corporation shall not be liable for any damages or problems arising from the use of any options or any consumable products other than those designated as Original Epson Products or Epson Approved Products by Seiko Epson Corporation.

Responsible Use of Copyrighted Materials

Digital cameras, scanners, and ink jet printers, like conventional photocopiers and cameras, can be misused by improper copying or printing of copyrighted material. While some countries' laws permit limited copying of copyrighted material in certain circumstances, those circumstances may not be as broad as some people assume. Epson encourages each user to be responsible and respectful of the copyright laws when using digital cameras, scanners, and ink jet printers.

Trademarks

Epson and Epson Stylus are registered trademarks and Exceed Your Vision is a trademark of Seiko Epson Corporation.

Epson Connection, Epson Store, and SoundAdvice are service marks of Epson America, Inc.

General Notice: Other product names used herein are for identification purposes only and may be trademarks of their respective owners. Epson disclaims any and all rights in those marks.

EPSON®
EXCEED YOUR VISION



410138900

Printed in XXXXXX XX.XX-XX XXX
CPD-19837