

BOSE[®]
Better sound through research[®]

Bose[®] Wave[®] Radio/CD

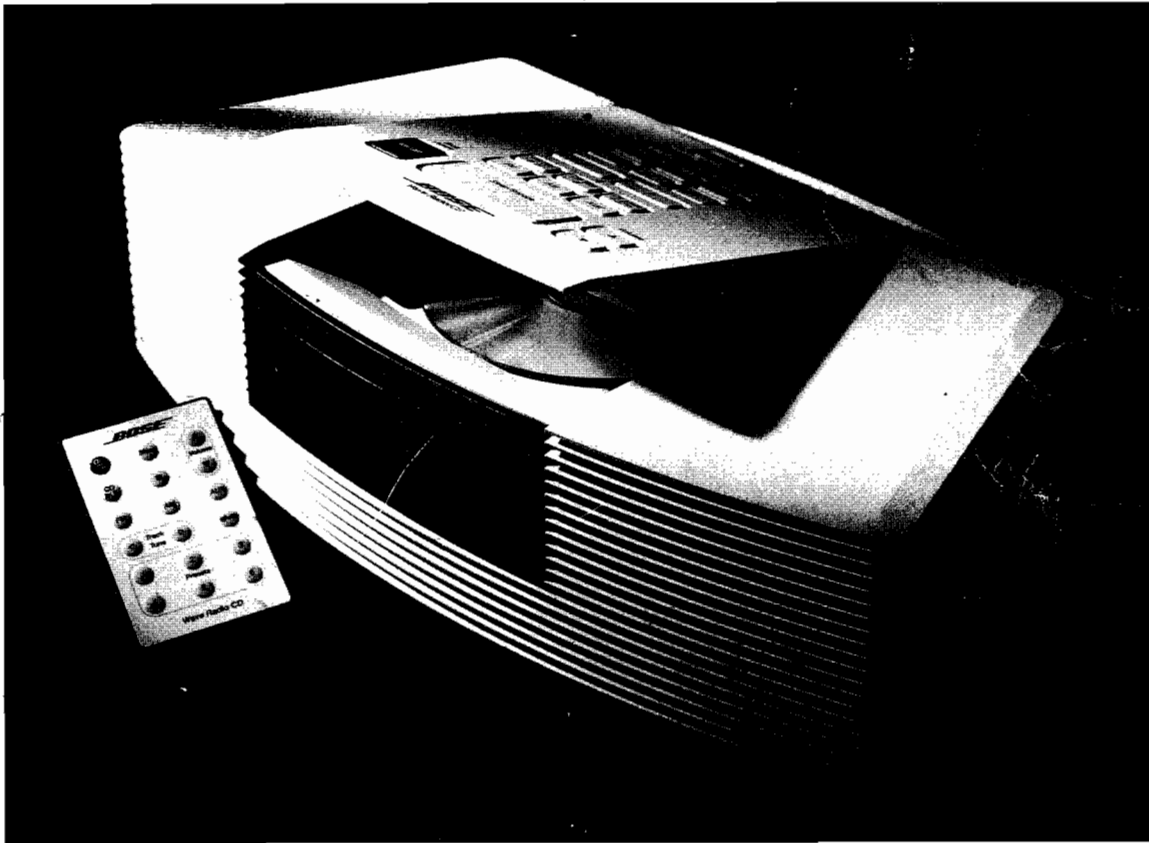

Contents

Safety Information	2
Electrostatic Discharge Sensitive (ESDS) Device Handling	2
Specifications	3-6
Theory Of Operation	7-11
Figure 1. APC PCB, ESD Solder Points	12
Disassembly/Assembly Procedures	12-13
Test Procedures	14-15
Figure 2. AM Test Setup	15
Test Procedures	16-17
Part List Notes	18
Main Assembly Part List	19
Figure 3. Exploded View	20
Electrical Part List	21-28
Packaging Part List	29
Figure 4. Keyboard Schematic Diagram	30
Abbreviated Operating Instructions	31

CAUTION: THE BOSE® WAVE® RADIO/CD CONTAINS NO USER SERVICEABLE PARTS. TO PREVENT WARRANTY INFRACTIONS, REFER SERVICING TO WARRANTY SERVICE STATIONS OR FACTORY SERVICE.

PROPRIETARY INFORMATION

THIS DOCUMENT CONTAINS PROPRIETARY INFORMATION OF BOSE® CORPORATION WHICH IS BEING FURNISHED ONLY FOR THE PURPOSE OF SERVICING THE IDENTIFIED BOSE PRODUCT BY AN AUTHORIZED BOSE SERVICE CENTER OR OWNER OF THE BOSE PRODUCT, AND SHALL NOT BE REPRODUCED OR USED FOR ANY OTHER PURPOSE.

Warranty Information

The Bose Wave Radio/CD is covered by a limited 1-year transferable warranty.

SAFETY INFORMATION

1. Parts that have special safety characteristics are identified by the  symbol on schematics or by special notes in the part lists. Use only replacement parts that have critical characteristics recommended by the manufacturer.

2. Make leakage current or resistance measurements to determine that exposed parts are acceptably insulated from the supply circuit before returning the unit to the customer. Use the following checks to perform these measurements:

A. Leakage Current Hot Check: With the unit completely assembled, plug the AC line cord directly into a 120 VAC outlet. (Do not use an isolation transformer during this test.) Use a leakage current tester or a metering system that complies with American National Standards Institute (ANSI) C101.1 "Leakage Current for Appliances" and Underwriters Laboratories (UL) 1492 (71). With the unit's AC switch first in the ON position and then in the OFF position, measure from a known earth ground (metal water pipe, conduit, etc.) to all exposed metal parts of the unit (antennas, handle bracket, metal cabinet, screw-heads, metallic overlays, control shafts, etc.), especially any exposed metal parts that offer an electrical return path to the chassis. Any current measured must not exceed 0.5 milliamp. Reverse the unit's power cord plug in the outlet and repeat the test. **ANY MEASUREMENTS NOT WITHIN THE LIMITS SPECIFIED HEREIN INDICATE A POTENTIAL SHOCK HAZARD THAT MUST BE ELIMINATED BEFORE RETURNING THE UNIT TO THE CUSTOMER.**

B. Insulation Resistance Test Cold Check: (1) Unplug the power supply and connect a jumper wire between the two prongs of the plug. (2) Turn on the power switch of the unit. (3) Measure the resistance with an ohmmeter between the jumpered AC plug and each exposed metallic cabinet part on the unit. When the exposed metallic part has a return path to the chassis, the reading should be between 1 and 5.2 Meg ohms. When there is no return path to the chassis, the reading must be "infinite". If it is not within the limits specified, there is the possibility of a shock hazard, and the unit must be repaired and rechecked before it is returned to the customer.

ELECTROSTATIC DISCHARGE SENSITIVE (ESDS) DEVICE HANDLING

This unit contains ESDS devices. We recommend the following precautions when repairing, replacing or transporting ESDS devices:

- Perform work at an electrically grounded work station.
- Wear wrist straps that connect to the station or heel straps that connect to conductive floor mats.
- Avoid touching the leads or contacts of ESDS devices or PC boards even if properly grounded. Handle boards by the edges only.
- Transport or store ESDS devices in ESD protective bags, bins, or totes. Do not insert unprotected devices into materials such as plastic, polystyrene foam, clear plastic bags, bubble wrap or plastic trays.

SPECIFICATIONS

Physical Description

Dimensions: 14" W x 8.5" D x 4.375" H (35.6 x 21.6 x 11.1) cm
Weight: 7.4 lb (3.4 kg)
Enclosure: Injection molded thermal plastic

Power Specifications

Input Line Voltage: 120V, 60 Hz, 50W
Power Consumption: ≤ 8 W with unit switched off
 ≤ 50 W with CD player on, maximum output

CD Specifications

	Nominal	Limit	Conditions
Maximum output level	2.0 V	±2.0 dB	0 dB
THD + noise	.03%	.08%	1 kHz, -6 dB
Signal to Noise Ratio	95 dB	90 dB	A-weighted
Channel separation	80 dB	70 dB	1 kHz
Frequency response	±5 dB	±1.0 dB	20 Hz-15 kHz
Low-level linearity error	5.0 dB	10.0 dB	-90 dB
De-emphasis	5 kHz 16 kHz	-4.53 dB -9.04 dB	±2.0 dB ±2.0 dB
Dynamic range	95 dB	90 dB	1 kHz, -60 dB, IEC-A, 20 kHz, LPF
Defect tracking (interruption)	1.0 mm	.8 mm	ABEX test disc TCD-725R
Defect tracking (black dot)	1.0 mm	.8 mm	ABEX test disc TCD-725R
Defect tracking (scratch)	1.6 mm	1.0 mm	ABEX test disc TCD-721R
Defect tracking (finger print)	75 μm	65 μm	ABEX test disc TCD-725R
Defect tracking (warped disc)	1.0 mm	.7 mm	ABEX test disc TCD-732RA
Defect tracking (eccentric disc)	280 μm	210 μm	ABEX test disc TCD-714R
Cueing time	2 sec	3 sec	Phillips TS4, tracks 1-15

Tuner Specifications

FM

FM Antenna: 75 Ohm external antenna connection, line cord functions as a FM antenna

Tuning range: US: 87.7 MHz-107.9 MHz
 Euro: 87.5 MHz-108.0 MHz
 Japan: 76.0 MHz-90.0 MHz

De-emphasis: US: 75 sec.
 Euro: 50 sec.
 Japan: 50 sec.

Frequency steps: US: 200 kHz
 Euro: 50 kHz
 Japan: 100 kHz

SPECIFICATIONS

(continued)

FM (continued)

FM specifications per IHF-T-200, unless otherwise noted. Measurement conditions, unless otherwise noted: RF input frequency 98.1 MHz, audio frequency 1 kHz, RF input level 65 dBf, Deviation: Mono 75 kHz, stereo 67.5 kHz, 7.5 kHz pilot. The performance specifications listed below apply across the entire FM band.

Specification Parameter	Nominal	Limit (Ambient/ Environmental ¹)
Sensitivity usable (C1 removed) US: Euro: Japan:	13 dBf 14 dBf 13 dBf	17/23 dBf 19/25 dBf 17/23 dBf
Sensitivity usable (C1 present ³) US: Euro: Japan:	15 dBf 16 dBf 15 dBf	19/25 dBf 21/27 dBf 19/25 dBf
Stereo (50 dB quieting) US: Euro: Japan:	43 dBf 45 dBf 43 dBf	48 dBf 50 dBf 48 dBf
Signal to noise ratio at 65 dBf Mono: Stereo:	70 dBf 65 dBf	65/60 dBf 60/55 dBf
Signal to hum ratio at 65 dBf ² Mono: Stereo:	80 dBf 80 dBf	75 dBf 75 dBf
Harmonic distortion (1 kHz) at 65 dBf Mono: Stereo:	.3% .6%	.6/2.0% 1.0/2.0%
Harmonic distortion (1 kHz) at 65 dBf with ARI ⁴	.6%	1.5%
Capture ratio	3.0 dB	4.0 dB
AM rejection at 45 dBf	55 dBf	50 dBf
Adjacent channel selectivity US: Euro:	15 dB 15 dB	10 dB 10 dB
Alternate channel selectivity US: Euro:	65 dB 65 dB	60 dB 60 dB
Image rejection	46 dB	40 dB
RF intermodulation	60 dB	55 dB
Subcarrier product rejection at 65 dBf	45 dB	40 dB
Frequency response 30 Hz-15 kHz	1.0 dB	3.0 dB
Stereo channel separation at 1 kHz	30 dB	20 dB
Auto stop level (seek)	32 dBf	5/10 dBf
Mono/stereo threshold	42 dBf	5/10 dB

Table notes:

¹Environmental limits apply from +10 to +40 C

²Signal to hum ratio is defined as the ratio of signal to hum and its harmonics

³To measure usable sensitivity with C1 present, configure power cord to run straight back from unit for one foot and then straight downward for the remainder of the power cord's length. Use an EMI filter or other method to provide RF isolation at the wall outlet.

⁴Use the standard European Broadcast Union ARI signal with 5 kHz signal on, DK signal on and BK signal code = F.

SPECIFICATIONS

(continued)

AM

AM Antenna: Internal bar antenna, turn unit to optimize AM reception

Channel spacing: US: 10 kHz
Euro: 9 kHz
Japan: 9 kHz

Band Limits: US: 520 kHz-1710 kHz
Euro: 522 kHz-1611 kHz
Japan: 522 kHz-1629 kHz

Test Parameter	530-550 kHz	560-590 kHz	600-700 kHz	710-950 kHz	960-1400 kHz	1410-1610 kHz	1620-1710 kHz
Usable sensitivity, dB V/m, 200 Hz HPF	55/63/69 nominal/limit/ environmental	54/59/65 nominal/limit/ environmental	51/56/62 nominal/limit/ environmental	50/55/61 nominal/limit/ environmental	49/54/60 nominal/limit/ environmental	48/53/59 nominal/limit/ environmental	50/55/61 nominal/limit/ environmental
Adjacent channel selectivity, dB	42/37 nominal/limit	42/37 nominal/limit	40/35 nominal/limit	35/30 nominal/limit	35/30 nominal/limit	35/30 nominal/limit	35/30 nominal/limit
Alternate channel selectivity, dB	55/50 nominal/limit	55/50 nominal/limit	55/50 nominal/limit	55/50 nominal/limit	55/50 nominal/limit	55/50 nominal/limit	55/50 nominal/limit
Image rejection ratio, dB	45/40 nominal/limit	45/40 nominal/limit	45/40 nominal/limit	45/40 nominal/limit	42/37 nominal/limit	35/30 nominal/limit	35/30 nominal/limit
Signal to noise, dB, at 100 dB V/M	50/40/35 nominal/limit/ environmental	50/40/35 nominal/limit/ environmental	50/40/35 nominal/limit/ environmental	50/40/35 nominal/limit/ environmental	50/40/35 nominal/limit/ environmental	50/40/35 nominal/limit/ environmental	50/40/35 nominal/limit/ environmental
Distortion, %, at 100 dB V/M	.8/1.4/2 nominal/limit/ environmental	.8/1.4/2 nominal/limit/ environmental	.8/1.4/2 nominal/limit/ environmental	.8/1.4/2 nominal/limit/ environmental	.8/1.4/2 nominal/limit/ environmental	.8/1.4/2 nominal/limit/ environmental	.8/1.4/2 nominal/limit/ environmental
Frequency response, dB, at 50 Hz, 1.8 kHz, at 100 dB V/M	-3/-6 nominal/limit	-3/-6 nominal/limit	-3/-6 nominal/limit	-3/-6 nominal/limit	-3/-6 nominal/limit	-3/-6 nominal/limit	-3/-6 nominal/limit
Conducted susceptibility	20	20	20	20	20	20	20
Com. mode, dB, min	25	25	25	25	25	25	25
Auto stop level, dB V/M	56	56	56	56	56	56	56

SPECIFICATIONS

(continued)

Audio

THD at amplifier output:	<.2% at 1 kHz, at 80% of maximum output
THD at line output:	<.2% at 1 kHz, 2.0 Vrms AUX input
Auxiliary input sensitivity:	400 mVrms at 1 kHz for full output. 2.0 Vrms maximum auxiliary input
Auxiliary input impedance:	20 k Ohms
Speaker output noise:	500 μ Vrms, maximum volume, inputs shorted
Signal to noise at line output:	85 dB
Volume control increments:	1.25 dB
Volume control range:	78.75 dB at 1 kHz
Battery backup:	9 V, lasts up to 24 hours (alarm only)

THEORY OF OPERATION

Note: All reference designators between 0 and 50 refer to components in the power supply and power amplifier on sheet 1 of the schematic. All reference designators between 200 and 299 refer to components in the voltage regulation section on sheet 2 of the schematic. All reference designators between 300 and 399 refer to components in the tuner section on sheet 3 of the schematic. All 400 series components are located on the Micro Controller PCB, shown on sheet 4 of the schematic. All reference designators between 500 and 599 refer to components in the CD section on sheet 5 of the schematic. All reference designators between 600 and 699 refer to components in the audio section on sheet 5 of the schematic.

1.0 Overview

The Wave Radio/CD is an AM/FM tuner, single disk CD player, and powered speaker system. In addition to the internal sources, external devices such as a tape deck can be connected through the unit's AUX input. An infrared (IR) remote control can be used to control the unit.

2.0 Power Supply Electronics

AC mains is connected through the line cord attached to the polarized jack **J1**. The neutral wire of the line cord is used as an FM antenna coupled by **C1**. **L1** and **L2** provide isolation between the **FM RF** input and the transformer **T1**. A slow acting fuse **F1** is connected between **J1** and the non-polarized jack **J2** to protect against faults.

Transformer **T1** is a round core (R-core) transformer with one primary winding (unique for different AC mains voltage requirements) and three secondary windings. The primary has a series thermal fuse to protect against overload and faults. Two of the three secondary windings have center taps. Polarized jack **J3** ensures the correct connection of the pins from **T1**.

The first secondary winding of **T1** provides the main audio power **V** and the CD motor power **VMOTOR**. Bridge rectifier **BR1** serves dual-purposes: it full wave rectifies the AC from two ends of the first secondary (without the center tap) (creating **V** when filtered by **C6**; part of it also rectifies through the center tap creating **VMOTOR** (about **V/2**)) when filtered by **C16**. The quiescent voltages of **V** and **VMOTOR** are about 15VDC and 7.5VDC, respectively. **V** provides power to the uC electronics (**+5V**) and the CD electronics (**+5VCD**). A 9V battery connected to **J200** also provides backup power for the uC in case of a power outage. The switching between **V** and **BAT+** is automatic through **D207**. **+5V** is regulated by **U202**, a voltage regulator with low dropout voltage and low quiescent current characteristics. Such characteristics are necessary to extend the battery life. **+5VCD** is regulated by **U203**. **R212** is a dissipating element for **U203**.

The second secondary winding of **T1** provides power to the audio and RF electronics: a positive voltage rectified by **D201** and filtered by **C205**; and a negative voltage rectified by **D200** and filtered by **C202**. The positive voltage is regulated by **U201** to generate **+10V** for the audio electronics. **R208** is a dissipating element for **U201**. The uC controls **+10V** and **+5VCD** through **Q207**, **D202**, **Q206** and **Q208**. In the off mode and battery backup mode the uC releases **TURNON**, turning off **Q206** and **Q208** and consequently **+10V** and **+5VCD**. In any other mode the uC asserts **TURNON**. The negative voltage is regulated by **U200** to provide **-15V** for the audio electronics. A reference voltage of **-20.6V** is created by the 5.6V zener diode **ZR200** and **R201** between **-15V** and the negative voltage. This **-20.6V** reference is buffered by **Q202** to make **-20V** for the **VFD** electronics. The **VFD** "center tap voltage" **CT** is generated from **-15V** by **Q201**. The uC controls the brightness of the **VFD** partly by changing the **CT** voltage. It does so through **AUD-DATA**, **Q210** and the resistor network **R231** and **R232**. **AUD-DATA** from the

THEORY OF OPERATION

uC is multiplexed and filtered by **R230** and capacitor **C231**. Normally in a bright environment, **AUD-DATA** is filtered to be high so **Q210** is turned off. The base of **Q201** is at the same voltage as -15V. Consequently **CT** is at about -14.4V. In a dark environment, **AUD-DATA** is filtered to be low so **Q210** is turned on. The presence of +5V at the resistor network changes the voltage at the base of **Q201**. **CT** is increased to about -9V, consequently reducing the display brightness.

The third secondary winding of **T1** provides AC power to the **VFD** filaments. It is nominally 5.3VAC. The center tap is connected to **CT** so that the **VFD** filaments are negatively biased.

R200 is used to protect **Q201** at power up. **R207**, **R211** and **R214** are fusible resistors protecting against faults.

A line frequency signal (60Hz) is generated from the secondary **MAIN**. **MAIN** is filtered by **R205** and **C215**, clamped by **D206**, and buffered by **Q200**. 60HZ (60Hz or 50Hz depending on the AC mains) is used by the uC to keep time and to detect a power failure.

3. Control Electronics

The embedded micro-controller (uC) used in this system is a Toshiba TMP87xx14F, where the xx digits define whether it is an OTP or a masked part. The main system power supply and the battery are connected to a low dropout low quiescent current regulator through **D207**: when the main power supply drops below the battery level, the battery will drive the uC. **U403** is an automatic reset chip that monitors the 5 volts at the uC and will pull pin 29 of the uC (**RESET**) low if the voltage drops below 4.75 volts; it also supplies the power-on reset pulse. **CF401** is an 8.00MHz ceramic resonator with built in capacitors.

U401 is an Electrically Erasable Read Only Memory that is used to store presets, AM and FM stop levels, the stereo threshold level and other pieces of data. All of the series resistors and shunting capacitors used on the signal lines leaving the uC are helping control conducted RF emissions from the uC. **D401** is a light sensor that in combination with **R420** provides a voltage related to the light level in the room. This voltage is read by the analog to digital converter at bit 7 of port 6 and is used in the **VFD** dimming algorithm. **Q401** is the infrared detector that works with the **IR** remote. The series resistors and shunting caps tied to the pins of the **VFD** are used to control RF emissions. The shunting resistors connected to six of the **VFD** control lines are used to help discharge the **VFD** lines when those particular segments or grids are to be turned off. **Q405** and **Q406** increase the current drive for two grids.

KEYIN1 through **KEYIN4** and **KEYOUT1** through **KEYOUT6** are routed to the button board through **J403** and form a button matrix. Normally, the uC holds the **KEYOUT** lines low and pins 59 through 62 of the uC, which correspond to the **KEYIN** lines, will be pulled low through **R468**, **R469**, **R470** and **R430**. The uC has internal 80k pull downs to -20 Volts on pins 59 through 62, so the voltage there will actually be less than 0. The transistors **Q400**, **Q402**, **Q403** and **Q404** are used for level shifting and current gain to overcome the resistance of the carbon ink button board. When a button is pressed, a **KEYOUT** line will pull current through the base of the corresponding **KEYIN** transistor and drive one of the pins on the uC high. The uC will now begin scanning the **KEYOUT** lines by pulling each line individually high one at a time. This way, when the **KEYIN** signal disappears the uC will know the corresponding **KEYOUT** line and which button in the matrix is pressed. The uC can now execute the desired command.

THEORY OF OPERATION

4.0 Audio Electronics

The two internal sources (CD and tuner) and the **AUX** input are routed to the audio multiplexer/volume control chip **U605**. **U605** selects one of the three inputs and routes the signal to pins 7 and 17 (right and left). These two signals are AC coupled to **J600** as Line Outputs. **Q602** and **Q603** buffer a signal (**BUZZER**) from the uC that is summed with the left channel for use as an alarm. The left and right signals then pass through matching EQ sections using **R655**, **R656**, **C645**, **C646** and **R660**, **R657**, **C665**, **C666**. These sections normally provide bass cut at loud volume settings. These EQ sections increase the deep bass for lower volume settings. This is the dynamic EQ for the product. The final stage of **U605** is the volume control. **U605** provides 80 dB of attenuation in 64 steps of 1.25 dB. The variable level signal is output on pins 24 and 25.

The audio signal is then split into two paths. The right and left signals are routed through **U600** and one quarter of **U601**, which provide active filtering for the left (full range) speaker output. The right signal is also routed through three-quarters of **U601** which provides active filtering for the right (twiddler) speaker output.

The two audio signals are fed to the power amplifier **U1**. **U1** is a bridged stereo power amp used for the right and left channels. The **U1** outputs are routed through **J5** and **J6** to the left and right drivers respectively. **U1** also contains a clip detector that is output on pin 4. This signal (**COMP**) controls the bias current of **U603**. When the amplifier is clipping, the bias current of **U603** is increased. The change in gain of **U603** reduces the bass frequency response of the left channel EQ. This is the compressor for the product.

Q4 is an amplifier that is connected to the twiddler. It amplifies the signal **BUZZER** only when the unit is not powered. The power for this comes from the nine-volt battery.

5. Tuner Electronics

There are two major ICs in the tuner section: **U300**, an **AM/FM** radio chip with a built in stereo de-multiplexer, and **U301**, a Phase Lock Loop (**PLL**) chip. The main system embedded controller (μ C) talks to the **PLL** chip using signals **AUD-DATA**, **PLL-DATA**, **AUD-CLK** and **PLL-CE**. The μ C controls whether the tuner is in **AM** or **FM** mode by forcing pin 8 of the **PLL** either high or low; a low puts **U300** in **AM** mode and disables power to the **FM-TUNER** and a high puts **U300** into **FM** mode and turns on power to the **FM-Tuner** via **Q300** and **Q301**.

In **FM** mode the frequency of the local oscillator (**LO**) located in the **FM-TUNER** is adjusted by the signal **FM_TV** which is applied to pin 5 of the **FM-TUNER**. The **LO** is then output on pin 8 and routed back to **U301** via **C338**. The **PLL** then compares the scaled frequency/phase of the **LO** against a reference which is a division of the 7.2MHz oscillator composed of **U301**, **C341**, **C342** and **CF303**. The result of this comparison determines the density and polarity of the phase pulses which are output on pin 16 of **U301**. The phase pulses then go into the loop filter composed of a MOSFET inside of **U301** (Ain and Aout) and the discrete components attached to pins 16, 17 and 18. The loop filter integrates the phase pulses to form the DC control voltage **FM_TV** thus completing the **LO** control loop.

THEORY OF OPERATION

Inside the **FM-TUNER**, the **LO** is mixed with the **RF** signal, coming from the F-Connector **J300** or off of the AC line cord neutral wire via **C1**, to produce an **IF** signal centered at 10.7MHz which is output on pin 7. The **IF** signal then passes through ceramic filter **CF300**, the common emitter amp containing **Q303**, **CF301** and is then routed into **U300**. Inside the chip the **IF** signal is limited and detected. The resonant LC circuit on pin 9 is part of the detector circuit. After detection, the stereo signal is then de-multiplexed inside the chip and the stereo channels are output onto pins 16 and 17. The ceramic resonator **CF302** is used by the stereo de-multiplexer's **VCO**. **C321**, **C320** and **R315** form the loop filter for the de-multiplexer's **PLL**. The left and right channel signals are then routed through the 19kHz pilot reject filters composed of **T303** and **T304**. The μC makes stop and stereo threshold decisions based on the level of the **S-METER** signal which is read by the analog to digital converter in the μC . The μC forces the radio into mono mode by telling **U301** to force its pin 9 low.

For **AM**, the Local Oscillator is composed of the LC resonant circuit, which is half of **D304** and **T302**, and an amplifier in **U300**. The **AM LO** signal comes out of pin 30 of **U300** and is fed into **U301** via **R330** and **C337**. The **PLL** chip compares the scaled **LO** frequency against a division of the 7.2MHz oscillator and outputs the appropriate phase pulses from pin 16 into the loop filter. The tuning voltage comes out of the loop filter through **R309** and appears across pins 1 and 2 of the varactor diode to complete the **AM LO** control loop.

The inductance of the **AM Bar Antenna** at pins 3 and 4 form a parallel resonance with the capacitance between pins 3 and 2 of the varactor diode producing frequency selectivity at the antenna. The **RF** at pin 1 of the antenna is routed into pin 27 of **U300**. The input circuitry at pin 27 is biased to 3.6 volts (V_{reg}) through **R308** and the coil wound between pins 1 and 2 on the antenna. Inside the chip, the **RF** is amplified and mixed down to an **IF** (intermediate frequency) of 450kHz. The **IF** is output on **U300** pin 2 and routed to the **IF** filtering in **T301**, the filtered **IF** then enters **U300** at pin 5 and passed through audio detection in the chip. The audio is then output onto pins 16 and 17.

6.0 CD Electronics

The CD circuitry consists of four major sections: the analog signal processor (**ASP**) **U500**, digital signal processor (**DSP**) **U501**, power driver **U502** and the CD mechanism. **U500** contains the RF amplifier and servo control circuits. **U501** performs **EFM** demodulation, **CIRC** decoding, digital filtering, D to A conversion and low-pass filtering. It also extracts the subcode Q data (track #, time, etc.).

U500 receives its input signal (through **J500**) from the mechanism's photo diode pickup. The inputs A, B, C and D are added together and amplified. The RF amplifier output appears on **RFSM** (**U500**, pin 41). This signal is the familiar eye pattern. This signal is sent to **EFMIN** on **U501** pin 10 where it is sliced for **EFM** demodulation. The sliced output appears on **EFMO** (**U501** pin 9). A low-passed version of this signal appears on **SLC** (**U500** pin 43) and is used as a DC bias for the **RFSM** signal.

The **RFSM** signal is peak detected and compared to a reference to determine if there is a signal being received from the disc. The output appears on **DRF** (**U500** pin 54). This signal is used by the μC to determine if the lens is in focus. The envelope of the **RFSM** signal is used to determine when the laser crosses a track boundary during track access. The **HFL** signal (**U500** pin 37) conveys this information to **U501**.

THEORY OF OPERATION

The **B+D** signal (**FIN2**) is subtracted from the **A+C** signal (**FIN1**). This produces the focus error signal **FE** (**U500 pin 20**). This signal is amplified and filtered by the focus servo amplifier within **U500**. It then appears as an output **FD** (**U500 pin 16**). The **FD** signal is fed to **U502**. **U502** generates a bridged output which is used to actuate the focus coil (**J500 pins 10 and 13**).

The **E** and **F** signals are buffered by **U500**. **E** is then subtracted from **F** and this difference is the track error signal **TE** (**U500 pin 7**). **TE** is used by both the anti-shock circuit and the tracking servo. **TE** is filtered at the **SCI** input (**U500 pin 9**) to determine if the system has had a shock. If this occurs, **U500** increases the track gain internally to compensate for the shock. The **TE** signal is amplified and filtered by the tracking servo amplifier within **U500**. It then appears as an output **TO** (**U500 pin 15**). The **TO** signal is fed to **U502**. **U502** generates a bridged output which is used to actuate the track coil (**J500 pins 11 and 12**).

The **TO** signal is also used as an input to the sled servo. This signal is filtered and fed to the sled servo amplifier on **SLEQ** (**U500 pin 28**). This signal is amplified and added to the **SLED** signals from the μ C. The sum appears on **SLD** (**U500 pin 29**) which is fed to **U502**. **U502** generates a bridged output to drive the sled motor (**J502 pins 5 and 6**).

The Constant Linear Velocity (**CLV**) servo is regulated by comparing the bit rate to a fixed reference frequency in **U501**. The error signal appears at **U501 pins 12 and 13** (**CLV+** and **CLV-**). These signals are subtracted and the difference appears on **SP** (**U500 pin 23**). The **SP** signal is filtered and amplified. The signal then appears at the output on **SPD** (**U500 pin 27**). **SPD** is fed to **U502**. **U502** generates a complimentary output which drives the spin motor (**J502 pins 1 and 2**).

U500 regulates the laser power by monitoring the **LDS** input (**J500 pin 8**). This signal is compared to a reference to generate the proper drive signal on **LDD** (**U500 pin 62**). This signal is buffered by **Q500**. The **Q500** output is amplified by **Q501**. **Q501** drives the laser diode output **LD** (**J500 pin 6**). **U500's** main DC reference voltage is **VREF** (**U500 pin 58**). This voltage is nominally 2.5V.

U500 receives servo control commands from the μ C on the serial bus (**U500 pins 51, 52 and 53**). These commands are used to start focus offset cancellation, track offset cancellation, **E/F** balance adjustment, focus initialization, laser **ON/OFF** and 8/12 cm spindle gain.

The **DSP** clock is derived from a 16.9344 MHz crystal oscillator (**CF500**). **U501** divides this clock by four to generate a **4.2336 MHz** signal that is output as the signal **4.2M** (**U501 pin 61**). **4.2M** is used as a system clock by the **ASP**.

U501 receives servo control commands from the μ C on the serial bus (**U501 pins 57, 56 and 54**). These commands include track jump, focus start, disk motor start/stop, muting on/off and track count. The tracking servo is controlled by the **TOFF** and **TGL** outputs (**U501 pins 17 and 18**). Track jumps are created by signals on the **JP+** and **JP-** lines (**U501 pins 19 and 20**). Track jump detection is based on signals from **U500** on the **HFL** and **TES** inputs. **U501** removes the subcode Q data from the bit stream and makes it available to the μ C. The μ C extracts track, time and table of contents information from the **subcode Q**.

U501 receives its **EFM** input from **U500** on **EFMIN** (pin 10). This signal is sliced, **EFM** demodulated and **CIRC** decoded. The digital audio signal is passed through a 4x over-sampling digital filter, D/A converter and low-pass filter. These outputs appear on **RCHO** and **LCHO** (**U501 pins 40 and 37**). The audio signals are routed to **U605**.

DISASSEMBLY/ASSEMBLY PROCEDURES

Note: The numbers in parentheses refer to the callouts in Figure 3.

1. Top Cover Removal

1.1 Remove the three screws (21) that secure the top cover (6) to the base (9).

1.2 Insert a flat blade screwdriver into the two locations shown in Figure 3. Apply force on the flat blade screwdriver so that the grille is moved outwards and clears the two tabs located on the base. See Figure 3.

1.3 Lift up on the top cover to remove it.

2. Top Cover Replacement

2.1 Lower the top cover (6) onto the base (9). Make sure that the ribbon cable that connects to the CD door (7) lays in the track to the left of the CD mechanism (2).

Note: The light shield (4) can get caught on the top cover. Make sure the light shield is secured in place when replacing the top cover.

2.2 With the palms of your hands located on the front corners of the top cover, firmly press down on the top cover until it snaps into place.

2.3 Replace the three screws (21) that secure the top cover to the base.

3. Display PCB Removal

3.1 Perform procedure 1.

3.2 Lift up the display PCB (1).

3.3 Remove the ribbon cable that connects the CD door (7) to the display PCB at the connector located on the display PCB. Remove the two ribbon cables that connect to the main PCB. Lift the display PCB out.

Caution: If you remove the ribbon cable from the CD door, you might have difficulties reconnecting the cable.

4. Display PCB Replacement

4.1 Replace the three ribbon cables that attach to the display PCB (1).

4.2 Lower the display PCB into the slots located on the matrix assembly (8).

5 CD Mechanism Removal

5.1 Perform procedure 1.

5.1 Lift the CD mechanism (2) up and solder the two points located on the CD mechanism's APC PCB. See Figure 1. This will prevent static electricity damage to the CD mechanism.

5.2 Remove the cables from the CD mechanism and lift the CD mechanism out.

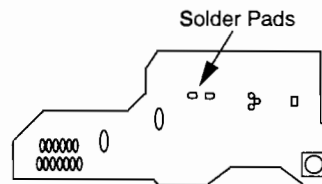

Figure 1. APC PCB, ESD Solder Points

6. CD Mechanism Replacement.

6.1 Attach the cables to the CD mechanism (2) and remove the solder from the two points indicated in Figure 1.

6.2 Lower the CD mechanism into the matrix assembly (8) so that the cables are toward the right speaker.

7. Twiddler™ and Full Range Driver Removal.

7.1 Perform procedure 1.

7.2 Remove the four screws (18) that secure the twiddler/full range driver (3, 4) to the matrix assembly (8). Pull out the driver from the matrix assembly and remove the soldered wires from the driver.

DISASSEMBLY/ASSEMBLY PROCEDURES

8. Twiddler® and Full Range Driver Replacement.

8.1 Solder the red wire to the positive (+) driver terminal and the black wire to the negative (-) driver terminal.

8.2 Align the driver (3, 4) into the matrix assembly (8) so that the wires feed through the channel on the top of the matrix assembly.

8.3 Replace the four screws (18) that secure the driver to the matrix assembly.

9. Transformer Removal

9.1 Perform procedure 1 first.

9.2 Remove the three screws (17) that secure the transformer (5) to the matrix assembly (8) and lift up the transformer.

9.3 Remove the two wire connectors that connect to the main PCB (1).

10. Transformer Replacement

10.1 Connect the two wire connectors to the main PCB (1).

10.2 Lower the transformer (5) into the matrix assembly and replace the three screws (17) that secure the transformer to the matrix assembly.

11. Main PCB Removal

11.1 Perform procedure 1 first.

11.2 Remove the two lower screws (17) that secure the transformer (5) to the matrix assembly (8). Remove the two screws (17) on the left side that secure the matrix assembly to the base (9).

11.3 Lift up the CD mechanism (2) and place it off to the side.

11.4 Lift up the display PCB (1) and lay it down in front of the unit.

11.5 Lift up on the matrix assembly (8), disconnect the wire connectors from the main PCB (1) and lift off the matrix assembly. Make a note of the way the wires are dressed.

11.5 Disconnect the two ribbon cables that connect the main PCB to the display PCB. Lift up the main PCB.

12. Main PCB Replacement

12.1 Lower the main PCB (1) into the base. Make sure that the nine volt battery connector is positioned properly in the battery compartment. Connect the ribbon cables from the display PCB (1) to the main PCB.

12.2 Partly lower the matrix assembly (8) onto the base and connect all the wire connectors to the main PCB and then completely lower the matrix assembly onto the base (9). Make sure the AC line cord is inserted into the notch on the base.

12.3 Replace the two screws on the left (17) that secure the matrix assembly to the base and the two screws (17) that secure the transformer (5) to the matrix.

TEST PROCEDURES

General Test Setup Procedures

Twiddler™ channel: Connect an $8 \Omega \pm 1\%$, 10 W load to J6, pins 1 and 2. The Twiddler is the right speaker, when viewed from the front of the unit.

Full range channel: Connect a $4 \Omega \pm 1\%$, 25 W load to J5, pins 1 and 2. The full range driver is the left speaker, when viewed from the front of the unit.

Adjust the volume to 64 unless otherwise noted.

Note: The door switch, located on the underside of the door, needs to be closed for the function buttons to work.

Audio Tests

1. Mute Test

1.1 Apply a 1 Vrms, 1 kHz signal to the left and right aux input.

1.2 Reference a dB meter to the Twiddler or full range output.

1.3 Press the mute button. The Twiddler or full range output should be < -55 dB.

2. Channel Separation

2.1 Apply a 1 Vrms, 1 kHz signal to the left aux input and short the right aux input.

2.2 Reference a dB meter to the full range output.

2.3 Measure the Twiddler output. It should be < -50 dB.

3. Compressor Distortion

3.1 Apply a 200 mVrms, 150 Hz signal to the left and right aux input. Adjust the volume to 99.

3.2 Measure the distortion at the full range output. It should be $< 5\%$.

4. DC Offset

4.1 Select the aux mode and short the left and right aux input.

4.2 Measure the Twiddler and full range outputs. They should be > -150 mVDC and $< +150$ mVDC.

5. Full Range Channel Output Noise

5.1 < 1.0 mV, A-weighted, inputs shorted.

6. Full Range Channel Reference Gain

6.1 Apply a 15 mVrms, 1 kHz signal to the left and right aux input. Adjust the volume to 99.

6.2 Reference a dB meter to the applied signal.

6.3 Measure the full range output. It should be $+22.0$ dB ± 2.2 dB.

7. Full Range Channel Frequency Response

7.1 Apply a 15 mVrms, 1 kHz signal to the left and right aux input. Adjust the Volume to 99.

7.2 Reference a dB meter to the full range output.

7.3 Measure the full range output according to the following table.

Frequency	Output
50 Hz	-8.3 ± 3.1 dB
90 Hz	$+16.5 \pm 2.4$ dB
300 Hz	$+4.8 \pm 1.3$ dB
500 Hz	-1.2 ± 1.1 dB
1.0 kHz	Reference
2.0 kHz	$+4.7 \pm 1.0$ dB
5.0 kHz	$+12.7 \pm 1.0$ dB
15 kHz	$+18.3 \pm 2.2$ dB

TEST PROCEDURES

8. Full Range Channel Dynamic EQ Gain

8.1 Apply a 15 mVrms, 1 kHz signal to the left and right aux input. Adjust the Volume to 49. Reference a dB meter to the full range output.

8.2 Apply a 1.5 mVrms, 80 Hz signal to the left and right aux input.

8.3 Measure the full range output. It should be $+3.5 \pm 1.0$ dB.

9. Full Range Channel Small Signal Distortion at 0.1 W

9.1 Apply a 30 mVrms, 1 kHz signal to the left and right aux input. Adjust the Volume to 99.

9.2 Measure the full range output. It should be $<0.5\%$ THD.

10. Full Range Channel Large Signal Distortion at 6 W

10.1 Apply a 200 mVrms, 1 kHz signal to the left and right aux input. Adjust the volume to 99.

10.2 Measure the full range output. It should be $<0.2\%$ THD.

11. Twiddler™ Channel Output Noise

11.1 Measure the Twiddler channel output. It should be <300 uV, A-weighted, inputs shorted.

12. Twiddler Channel Reference Gain

12.1 Apply a 50 mVrms, 1 kHz signal to the left and right aux input. Adjust the volume to 99.

12.2 Reference a dB meter to the applied signal.

12.3 Measure the Twiddler output. It should be $+20.5 \pm 2.0$ dB.

13. Twiddler Channel Frequency Response

13.1 Apply a 50 mVrms, 1 kHz signal to the left and right aux input. Adjust the Volume to 99.

13.2 Reference a dB meter to the Twiddler output.

13.3 Measure the Twiddler output according to the following table.

Frequency	Output
200 Hz	-15.6 ± 1.3 dB
400 Hz	-4.6 ± 1.2 dB
550 Hz	-1.8 ± 1.0 dB
1 kHz	Reference
3 kHz	-3.7 ± 1.0 dB
10 kHz	$+9.1 \pm 1.0$ dB
20 kHz	$+6.6 \pm 1.5$ dB

14. Twiddler Channel Small Signal Distortion at 0.5 W

14.1 Apply a 130 mVrms, 1 kHz signal to the left and right input. Adjust the volume to 99.

14.2 Measure the Twiddler channel output. It should be $<0.1\%$ THD.

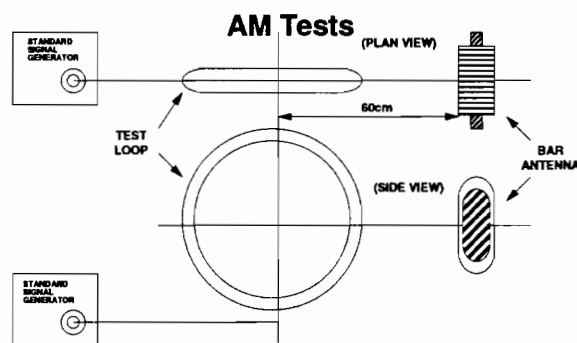

Figure 2. AM Test Setup

15. AM Tracking Alignment

15.1 Adjust the RF generator to 1500 kHz, 400 Hz, 30% AM modulation at a level of 70 dBuV/m at the unit's antenna.

TEST PROCEDURES

15.2 Adjust C307 for peak audio output measured at the line output.

15.3 Adjust the RF generator to 600 kHz, 400 Hz, 30% AM modulation at a level of 70 dBuV/m at the unit's antenna.

15.4 Adjust T302 for peak audio output measured at the line output.

15.5 Adjust the RF generator to 1500 kHz, 400 Hz, 30% AM modulation at a level of 70 dBuV/m at the unit's antenna.

15.6 Adjust C307 for peak audio output measured at the line output.

16. AM Sensitivity

16.1 Adjust the RF generator to 1080 kHz, 400 Hz, 30% AM modulation at a level of 53 dBuV/m at the unit's antenna.

16.2 Reference a dB meter to the aux output.

16.3 Turn off the modulation and measure the aux output. It should be <-20 dB.

17. AM Stop Level Adjustment

17.1 Adjust the RF generator to 1080 kHz, no modulation at a level of 59 dBuV/m at the unit's antenna.

17.2 Press the CD Mode, AM and Alarm 2 buttons at the same time to store the AM stop level.

17.3 Adjust the RF generator to 1130 kHz (1125 kHz for Euro/Japan), 30% modulation, 400 Hz modulation at a level of 59 dBuV/m at the unit's antenna input. Press the seek button and verify the tuner stops at 1130 kHz.

FM Tests

18. FM Detector Adjustment

18.1 Adjust the FM generator to 98.1 MHz (87.5 MHz for Japan), 1 kHz modulation, pilot off, 75 kHz deviation and at a level of 40 dBf into the antenna input.

18.2 If the THD measured at the line output is greater than .5%, adjust T300 until the THD is less than .5%. Verify the line output is 560 mVrms \pm 200 mVrms.

19. Stereo Separation

19.1 Adjust the RF generator to 98.1 MHz (87.5 MHz for Japan), 1 kHz stereo left only modulation, 10% pilot, 75 kHz deviation at a level of 65 dBf into the antenna input.

19.2 Reference a dB meter to the left line output.

19.3 Switch the RF generator to right only modulation. Verify that the left line output is \leq -25 dB.

20. FM Stop Level Adjustment

20.1 Adjust the RF generator to 98.1 MHz, no modulation at a level of 30 dBf into the antenna input.

20.2 Press the CD mode, FM and alarm 2 buttons at the same time to store the FM stop level.

20.3 Adjust the RF generator to 98.9 MHz, 1 kHz modulation, 75 kHz deviation at level of 35 dBf into the antenna input. Press the seek button and verify the tuner stops at 98.9 MHz.

21. Stereo Threshold Adjustment

21.1 Adjust the RF generator to 98.1 MHz, 10% pilot, 75 kHz deviation at a level of 42 dBf into the antenna input.

TEST PROCEDURES

21.2 Press the CD mode, FM and CD stop button at the same time to store the stereo threshold.

22. FM Sensitivity

22.1 Adjust the RF generator to 98.1 MHz, 1 kHz stereo L = R modulation, 10% pilot, 75 kHz deviation at a level of 48 dBf into the antenna input. Reference a dB meter to the line output.

22.2 Turn off the modulation and verify that the line out is ≤ 50 dB (≤ 45 dB for European version).

CD Tests

23. CD Performance Test



23.1 The BWR/CD should be able to play the test discs listed in the following table for the amount of time stated without any audible defects. There are no CD adjustments that can be made to the BWR/CD. If the unit fails any of these tests, replace the CD mechanism.

Test	Disc	Test Conditions
Defect tracking (void), 1.0 mm	ABEX test disc TCD-725R	Track 6, 6 sec.
Defect tracking (black dot), .8 mm	ABEX test disc TCD-725R	Track 9, 8 sec.
Defect tracking (finger print), 65 μ m	ABEX test disc TCD-725R	Track 13, 10 sec.
Defect tracking (warped disc), 1.0 mm	ABEX test disc TCD-732RA	First and last track, 6 sec.
Defect tracking (eccentric disc), 210 μ m	ABEX test disc TCD-714R	First and last track, 6 sec.
Cueing time, 2 sec	Phillips TS4, tracks 1-15	Skip first to last track
Long Playability, 71' 42"	ABEX test disc TCD-784	Last track, 6 sec.

PART LIST NOTES

1. This part is not normally available from customer service. Approval from the Field Service Manager is required before ordering.
2. The individual parts located on the PCB are listed in the electrical part list.
3.  This part is critical for safety purposes. Failure to use a substitute replacement with the same safety characteristics as the recommended replacement part might create shock, fire and/or other hazards.
4. Part numbers 193430-001 and 193431-001 are the full-range and Twiddler™ drivers with the wire harness attached. Part numbers 145588 and 148704 are the full-range and Twiddler drivers without the wire harness attached.
5. There are two white color versions of the Bose® Wave® Radio. White units manufactured in 1998 are imperial white. White units manufactured starting in 1999 are platinum white. The first two digits of the date of manufacture (D.O.M.), which is located on the bottom of the unit, indicates the year the unit was manufactured.
6. U401 is an Electrically Erasable Read Only Memory that is used to store presets, AM and FM stop levels, the stereo threshold level and other pieces of data. If U401 is replaced, perform test procedures 17, 20 and 21 to store the AM/FM stop levels and the stereo threshold.

MAIN ASSEMBLY PART LIST

Item Number	Description	Part Number	Note
1	PCB ASSY, WR/CD, 120V	193321-1	1, 2
2	CD MECHANISM, CD93V4M	193373	 3
3	FULL-RANGE, 57mm, WITH HARNESS, LEFT FULL-RANGE, 57mm, W/O HARNESS, LEFT	193430-001 145588	4
4	TWIDDLER™, 57mm, WITH HARNESS, RIGHT TWIDDLER, 57mm, W/O HARNESS, RIGHT	193431-001 148704	4
5	TRANSFORMER, R-CORE, 120V, 60HZ	193372	 3
6	TOP COVER ASSY, IMPERIAL WHITE TOP COVER ASSY, GRAPHITE GRAY TOP COVER ASSY, PLATINUM WHITE	198613-001 198613-002 198613-010	5
7	DOOR ASSY, IMPERIAL WHITE DOOR ASSY, GRAPHITE GRAY DOOR ASSY, PLATINUM WHITE	198608-001 198608-002 198608-010	5
8	MATRIX ASSY, BLACK	193376-011	1
9	PEDESTAL ASSY, BLACK	198614-001	
10	LENS, GREEN	193392-001	
11	SHIELD, LIGHT, CONTOURED	199608	
12	CABLE, FLEX, 21 CONDUCTOR	193394-100	
13	CABLE, FLEX, 13 CONDUCTOR	193374-100	
14	HARNESS, 6 CONDUCTOR	193375-001	
15	GROMMET, RUBBER, CUSHION, RED DOT	193382	
16	GROMMET, RUBBER, CUSHION, WHITE DOT	193380	
17	SCREW, TAPP, 8-11x.625, PAN, XRC/S	172672-10	
18	SCREW, HILO, 6x.5, PAN, XREC	175972-08	
19	LINE CORD, 110V, 2 COND, BLK	193395-001	 3
20	CABLE, FLEX, 15 CONDUCTOR	193384-100	
21	SCREW, TAP, 8-11X.625, PAN, XRC/SQ	193637-10	
-	CLIP, DAMPER	193428	
-	GEAR, DAMPER, WHITE	146816-04	
-	FELT FOOT	193460	
-	BATTERY DOOR, BLACK	193409-001	
-	SPRING, EXTENSION	193379	

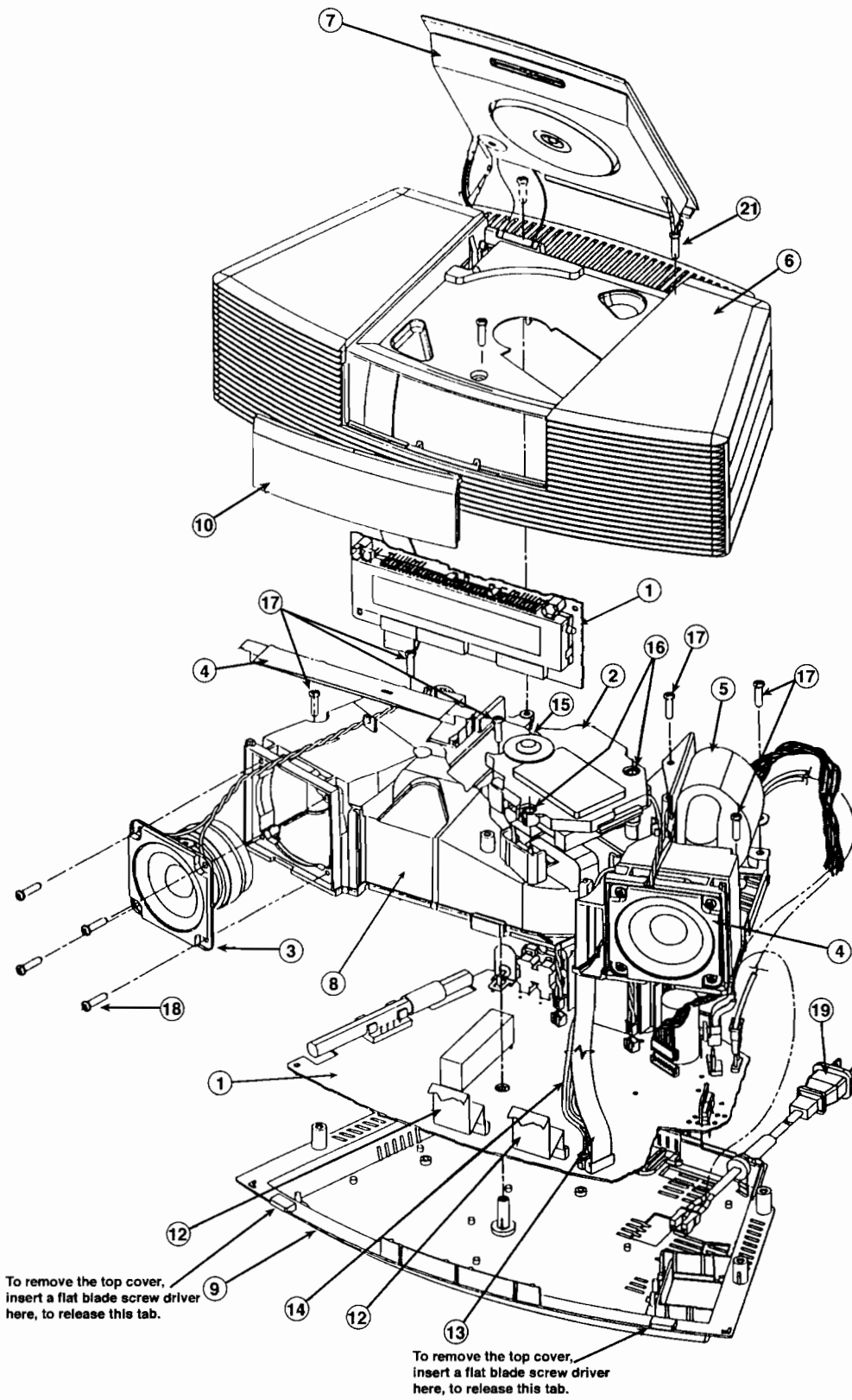

Figure 3. Exploded View

ELECTRICAL PART LIST

Resistors

Reference Designator	Description	Part Number	Note
R1	10M, CF, 1/2W, 5%	121243-1511065	⚠ ³
R2	POLYSWITCH, 60V	194090	
R6, 565	10Ω, CHIP, 0805, 5%	133626-1005	
R8, 332, 529, 545	33.2K, CHIP, 0805, 1/10W, 1%	133625-3322	
R9, 10, 200, 205, 206, 310, 467, 559, 568	47.0K, 0805, 1/10W, 5%	133626-4735	
R201, 204, 307, 336, 410	4.7K, CHIP, 0805, 5%	133626-4725	
R202, 203, 210, 215, 333, 334, 354, 412, 413, 414, 416, 417, 418, 421, 422, 445, 448, 455, 462, 466, 485, 580, 670	10.0K, 0805, 1/10W, 5%	133626-1035	
R207, 211	15Ω, FUSING, .25W	130102-150	⚠ ³
R208	330Ω, 2512, 1W, 5%	181895-3300	
R212	510Ω, 2010, 1/2W, 5%	187608-5115	
R214	5.1Ω, FUSING, .25W	130102-5R1	⚠ ³
R220, 300, 316, 330, 335, 339, 370, 371, 402, 403, 404, 405, 406, 411, 477, 500, 506, 554, 561, 566, 574, 575, 647, 650, 659, 662, 664, 665, 666	1.00K, 0805, 1/10W, 5%	133626-1025	
R230, 649, 651	100K, 0805, 1/10W, 5%	133626-1045	
R231, 331, 543, 600, 601, 612	10.0K, 0805, 1/10W, 1%	133625-1002	
R232, 350, 351, 510	3.32K, 0805, 1/10W, 1%	133625-3321	
R301	120Ω, 0805, 1/10W, 1%	133625-1200	
R302, 304, 356	2.32K, 0805, 1/10W, 1%	133625-2321	
R303, 501	499Ω, CHIP, 0805, 1/10W, 1%	133625-4990	
R305, 355	330Ω, 0805, 1/10W, 1%	133625-3300	
R306, 461	51Ω, 0805, 1/10W, 5%	133626-5105	
R308, 656, 660	4.99K, 0805, 1/10W, 1%	133625-4991	
R309, 610	4.02K, 0805, 1/10W, 1%	133625-4021	
R311	30.1Ω, 0805, 1/10W, 1%	133625-30R1	
R313, 558	20Ω, 0805, 1/10W, 5%	133626-2005	
R314, 630, 631	8.87K, 0805, 1/10W, 1%	133625-8871	
R315	3.0K, CHIP, 0805, 1/10W, 5%	133626-3025	
R323, 341, 515, 569, 570	2.21K, CHIP, 0805, 1/10W, 1%	133625-2211	
R324, 447	5.10K, 0805, 1/10W, 5%	133626-5125	
R337, 639	475Ω, 0805, 1/10W, 1%	133625-4750	
R338, 471, 472, 473, 474	6.80K, 0805, 1/10W, 5%	133626-6825	
R340, 342	100Ω, CHIP, 0805, 1/10W, 5%	133626-1015	
R344	470K, 0805, 1/10W, 5%	133626-4745	
R352, 353	4.3K, CHIP, 0805, 1/10W, 5%	133626-4325	
R357, 449	3.01K, 0805, 1/10W, 1%	133625-3011	
R400, 401	1.0K, ARRAY, SMT, 8POS, 5%	186433-1028	
R419	1.0K, ARRAY, SMT, 4POS, 5%	186433-1024	
R420, 450, 460	1.0M, 0805, 1/10W, 1%	133625-1004	

ELECTRICAL PART LIST

Resistors (Continued)

Reference Designator	Description	Part Number	Note
R428, 429, 431, 432	82K, CHIP, 0805, 1/10W, 5%	133626-8235	
R430, 468, 470, 469, 552	681Ω, CHIP, 0805, 1/10W, 1%	133625-6810	
R440	220Ω, ARRAY, SMT, 4POS, 5%	186433-2214	
R441, 442, 443, 480	2.7K, ARRAY, SMT, 4 POS 5%	186433-2724	
R463	150Ω, CHIP, 0805, 1/10W, 1%	133625-1500	
R464	243Ω, 0805, 1/10W, 1%	133625-2430	
R465	47Ω, CHIP, 0805, 1/10W, 5%	133626-4705	
R475, 476	16.5K, CHIP, 0805, 1%	133625-1652	
R490, 491	510Ω, 0805, 1/10W, 5%	133626-5115	
R495, 571	JUMPER, CHIP, 0805	133627	
R503	13.3K, 0805, 1/10W, 1%	133625-1332	
R504, 562	27.4K, CHIP, 0805, 1/10W, 1%	133625-2742	
R505	562Ω, 0805, 1/10W, 1%	133625-5620	
R507, 668, 669	100K, 0805, 1/10W, 1%	133625-1003	
R508, 553	68.1K, 0805, 1/10W, 1%	133625-6812	
R509, 519, 537, 549, 556, 560, 642	15.0K, 0805, 1/10W, 1%	133625-1502	
R513, 527, 557	1Ω, 0805, 1/10W, 5%	133626-1R05	
R514	8.25K, CHIP, 0805, 1/10W, 1%	133625-8251	
R516, 535, 536, 572, 573, 637	221K, 0805, 1/10W, 1%	133625-2213	
R520, 538, 546	22.1K, 0805, 1/10W, 1%	133625-2212	
R521, 522	7.50K, 0805, 1/10W, 1%	133625-7501	
R528, 608	12.7K, 0805, 1/10W, 1%	133625-1272	
R530	20.0K, CHIP, 0805, 1/10W, 1%	133625-2002	
R531	2.74K, 0805, 1/10W, 1%	133625-2741	
R532, 534	56.2K, CHIP, 0805, 1%	133625-5622	
R533	1.82K, 0805, 1/10W, 1%	133625-1821	
R539	270K, 0805, 1/10W, 5%	133626-2745	
R540, 550	332Ω, CHIP, 0805, 1%	133625-3320	
R544	47.5K, CHIP, 0805, 1/10W, 1%	133625-4752	
R547	12.1K, 0805, 1/10W, 1%	133625-1212	
R548, 667, 672	1.00K, CHIP, 0805, 1/10W, 1%	133625-1001	
R551	1.21K, 0805, 1/10W, 1%	133625-1211	
R555	15K, CHIP, 0805, 1/10W, 5%	133626-1535	
R603, 605, 632	1.10K, 0805, 1/10W, 1%	133625-1101	
R604, 606	14.7K, CHIP, 0805, 1%	133625-1472	
R607	5.62K, CHIP, 0805, 1/10W, 1%	133625-5621	
R609	35.7K, 0805, 1/10W, 1%	133625-3572	
R611	3.48K, 0805, 1/10W, 1%	133625-3481	
R613	1.87K, 0805, 1/10W, 1%	133625-1871	

ELECTRICAL PART LIST

Resistors (continued)

Reference Designator	Description	Part Number	Note
R615, 625	14.0K, CHIP, 0805, 1%	133625-1402	
R616, 617	6.81K, CHIP, 0805, 1/10W, 1%	133625-6811	
R618	1.40K, 0805, 1/10W, 1%	133625-1401	
R619	10.5K, 0805, 1/10W, 1%	133625-1052	
R620	11.3K, 0805, 1/10W, 1%	133625-1132	
R621, 629	3.74K, 0805, 1/10W, 1%	133625-3741	
R622	30.1K, CHIP, 0805, 1/10W, 1%	133625-3012	
R623	4.75K, 0805, 1/10W, 1%	133625-4751	
R624	1.27K, 0805, 1/10W, 1%	133625-1271	
R626	41.2K, 0805, 1/10W, 1%	133625-4122	
R627	715Ω, 0805, 1/10W, 1%	133625-7150	
R628	2.10K, 0805, 1/10W, 1%	133625-2101	
R633	26.7K, 0805, 1/10W, 1%	133625-2672	
R634	787Ω, 0805, 1/10W, 1%	133625-7870	
R635, 638	25.5K, 0805, 1/10W, 1%	133625-2552	
R636	2.00K, 0805, 1/10W, 1%	133625-2001	
R640	10.2K, CHIP, 0805, 1/10W, 1%	133625-1022	
R643	8.2K, CHIP, 0805, 1/10W, 5%	133626-8225	
R645	4.22K, 0805, 1/10W, 1%	133625-4221	
R655, 657	75.0K, 0805, 1/10W, 1%	133625-7502	
R663	150K, 0805, 1/10W, 1%	133625-1503	
R674	1.78K, 0805, 1/10W, 1%	133625-1781	

Capacitors

Reference Designator	Description	Part Number	Note
C1	33pF, CER, 85, 400VAC, 20%	183627-330	⚠ ³
C2, 3, 4, 5, 461, 627, 629	.1uF, 1206, X7R, 25V, 5%	131754-104	
C6	10000uF, EL, 25V	171555	
C7, 503	.22uF, BOX, 85, 50V, 5%	137127-224	
C8, 620, 621	.47uF, BOX, 85, 50V, 5%	137127-474	
C9, 10, 528, 563	220pF, 0805, COG, 50V, 5%	133622-221	
C11, 315, 336, 417, 465, 475, 511, 522, 554, 687, 688, 689	.01uF, 0805, X7R, 50V, 10%	133623-103	
C12, 520, 521, 550	100uF, EL, 85, 16V, 20%	149947-101C	
C13	.001uF, 1206, COG, 50V, 5%	177214-102	
C15, 217, 219, 378, 466, 545, 549, 551, 553, 557	.10uF, 0805, Y5V, 25V, 80%	133624	
C16	2200uF, EL, 105C, 20%, 16V	198458-222C	
C20, 200, 201, 209, 216, 232, 225, 210, 203, 215, 231	.047uF, 0805, X7R, 50V, 10%	133623-473	
C202, 205	470uF, EL, 105, 35V, 20%	144000-471V	
C211, 226, 227, 371, 376, 400, 401, 402, 403, 404, 405, 413, 416, 462, 463, 464, 469, 478, 479, 485, 571	330pF, 0805, COG, 50V, 5%	133622-331	

ELECTRICAL PART LIST

Capacitors (continued)

Reference Designator	Description	Part Number	Note
C218	10uF, EL, 105, 16V, 20%	137126-100	
C220, 630, 631, 636, 637, 650	2.2uF, EL, 85, 50V, 20%	149947-2R2H	
C221, 356, 357, 384, 385, 386, 418, 422, 423, 424, 470, 471, 540, 546, 634, 635, 640, 641, 655, 656, 657, 658, 682, 683, 684, 685	100pF, 0805, COG, 50V, 5%	133622-101	
C229, 318	2.2uF, EL, 85, 50V, 20%	149948-2R2H	
C233, 468	1uF, 1206, Y5V, 16V, 80%	173383-105	
C300, 332, 337, 338, 339, 348, 349, 355, 377, 382, 387, 415, 419, 425, 472, 473, 474, 476, 477, 493, 494, 495, 560, 562, 639, 651, 652	1000pF, 0805, COG, 50V, 5%	133622-102	
C301, 303, 305, 310, 312, 316, 319, 330, 331, 343, 345, 412, 561	.047uF, 0805, Z5U, 20%	148779-473	
C302, 532, 552	47uF, EL, 85, 16V, 20%	149947-470C	
C304	6.8pF, CHIP, 0805, 50V, 5%	133622-6R8	
C307	20pF, TRIM, NPO, 100V, T&R	197314-T200	
C308	430pF, 0805, COG, 50V, 2%	177269-431	
C309, 313, 317	47uF, EL, 85, 25V, 20%	149948-470E	
C311	3.3uF, EL, 85, 50V, 20%	149948-3R3H	
C314, 426	2.2uF, MONO, 1206, Y5V, 16V, 80%	178212-225	
C320, 323, 333, 365, 366	1.0uF, EL, 85, 50V, 20%	149948-1R0H	
C321	.47uF, EL, 85, 50V, 20%	149948-R47H	
C325, 329	10uF, EL, 85, 25V, 20%	149948-100E	
C328	1.0uF, EL, BP, 85, 50V, 20%	147522-1R0	
C335, 667, 681	2.2uF, EL, BP, 85, 50V, 20%	147522-2R2	
C340, 406, 407, 408, 409, 410, 411	3300pF, 0805, X7R, 50V, 10%	133623-332	
C341, 342	39pF, 0805, COG, 5%	133622-390	
C344	100uF, EL, BP, 85, 16V, 20%	147522-101	
C358, 502, 523, 531, 624	10uF, EL, 85, 25V, 20%	149947-100E	
C359, 534, 555, 556, 647	4.7uF, EL, 85, 50V, 20%	149947-4R7H	
C360, 375, 380, 381, 414, 480, 481, 482, 483, 504, 570	330pF, 0805, COG, 50V, 5%	133622-331	
C367, 368	1800pF, 0805, COG, 50V, 5%	133622-182	
C388	33pF, 0805, COG, 50V, 5%	133622-330	
C434, 435, 436, 437	47pF, 0805, COG, 50V, 5%	133622-470	
C438, 439	1.0uF, 1206, Y5V, 25V, 80%	198609-105	
C440, 467	15uF, TANT, 25V, 10%, D SIZE	196981-E156D1	
C441, 452	180pF, 0805, COG, 50V, 5%	133622-181	
C442, 443, 444, 446, 447, 448, 449, 450, 451, 453, 454, 455, 457, 458, 459, 460, 610, 619	820pF, 0805, COG, 50V, 5%	133622-821	

ELECTRICAL PART LIST

Capacitors (continued)

Reference Designator	Description	Part Number	Note
C445	2200pF, 0805, X7R, 50V, 10%	133623-222	
C456, 490, 491, 492	4700pF, 0805, X7R, 50V, 10%	133623-472	
C505	.015uF, BOX, 85, 100V, 5%	137127-153	
C506, 622, 623	.047uF, BOX, 85, 63V, 5%	137127-473	
C507, 513, 611, 612	.033uF, BOX, 85, 63V, 5%	137127-333	
C508, 529	.0033uF, BOX, 85, 100V, 5%	137127-332	
C509, 512, 525, 526	.15uF, BOX, 85, 50V, 5%	137127-154	
C510	220uF, EL, 85, 6.3V, 20%	149947-221J	
C514, 538	.001uF, BOX, 85, 100V, 5%	137127-102	
C519	.022uF, 0805, X7R, 50V, 10%	133623-223	
C524, 558	1.0uF, EL, 85, 50V, 20%	149947-1R0H	
C533	.47uF, EL, BP, 85, 50V, 20%	147522-R47	
C535, 607, 608	.33uF, BOX, 85, 50V, 5%	137127-334	
C536, 543, 544, 600, 616, 617	.1uF, BOX, 85, 50V, 5%	137127-104	
C537, 527, 530, 542, 602, 603, 614, 615	.01uF, BOX, 85, 100V, 5%	137127-103	
C539	3.9pF, 0805, COG, 50V, 5%	133622-3R9	
C541	12pF, 0805, COG, 50V, 5%	133622-120	
C547, 548	10pF, 0805, COG, 50V, 5%	133622-100	
C601	.027uF, BOX, 85, 63V, 5%	137127-273	
C605, 606, 645, 646, 665, 666	.18uF, BOX, 85, 50V, 5%	137127-184	
C609	.0047uF, BOX, 85, 100V, 5%	137127-472	
C613	.0056uF, BOX, 85, 100V, 5%	137127-562	
C618	.0022uF, BOX, 85, 100V, 5%	137127-222	
C628	1206, X7R, 25V, 5%, .1uF	131754-104	
C642	22uF, EL, 85, 16V, 20%	149947-220C	
C686	470uF, EL, 85, 16V, 20%	149948-471C	

Diodes

Reference Designator	Description	Part Number	Note
D1, 204, 206, 300, 302, 305	DUAL, SOT-23, BAV99	147239	
D3, 202, 207, 600	DUAL, SOT-23, COMMON NEG	250682	
D200, 201	SMT, S1G	178380-4	
D304	VARACTOR, DUAL, 20V, 50mA	177495-5	
D401	SENSOR, LIGHT, VSIBLE	187629-001	
ZR200	ZENER, 5.6V, 225MW, 1N5232	135247-5232	
BR1	RECTIFIER, BRIDGE, KBJ601G	187611-001	⚠ ³

ELECTRICAL PART LIST

Transistors

Reference Designator	Description	Part Number	Note
Q4, 210, 500	BPLR, P, 40V, 200mA, SOT23	148596	
Q200, 209, 301, 603	BPLR, N, 50V, 100mA, SOT23	146817	
Q201, 202, 206, 208	BPLR, P, 60V, 200mA, TO-92	119168	
Q207	BPLR, N, 4.7K, SOT23	192603	
Q300, 400, 402, 403, 404, 600, 602	P, 50V, 2SA1341	146818	
Q303	BPLR, N, 25V, 30MA, SOT-23	187601-001	
Q304	BPLR, N, 55V, 150mA, SOT23	134741	
Q401	SENSOR, IR DETECTING	182493-38	
Q405, 406	NPN, HfFe, SOT-23	250681	
Q501	N, 2SD8790V, TO-92	193457	

Integrated Circuit

Reference Designator	Description	Part Number	Note
U1	POWERAMP, MW15, TDA7375A	250117	
U200	IC, VOLTREG, 15V, NEG, TO-92	193423-15	
U201	LM78M10, T220	178352-10	
U202	VOLT REG, POS, 5V, LO-VD/IQ	193401-05R0	
U203	LM78M05, T220	178352-05	
U300	AM/FM TUNER, SO-20LA1836	187600-001	
U301	PLL FREQ SNTH, MFP20, LC72131	187733-001	
U400	UC, OTP, TMP87PM14F	187730-001	
U401	EEPROM, 1K, 24C01A	184044	6
U403	RESET, SOT23, MAX809, 4.65V	191158-01	
U500	CDASP, QFP64, LA9241M	187721-001	
U502	MOTOR DRIVER, DIP30, LA6541D	193432	
U600, 601	QUAD OPAMP, TLO74D, SOIC	186112	
U603	TRANS, DUAL, SOIC-16, NJM13700	188650-001	
U605	VOLCONT, DIP28/SO28TDA7313	177983	

Ceramic Filters

Reference Designator	Description	Part Number	Note
CF300	FILTER, CER, 10.7MHZ, 230KHZ	147559	
CF301	FILTER, CER, 10.7MHZ, 180KHZ, FGD	191157	

ELECTRICAL PART LIST

Ceramic Filters (continued)

Reference Designator	Description	Part Number	Note
CF302	RESONATOR, CERAMIC, 456KHz	187604-001	
CF303	CRYSTAL, FUND, 7.2MHZ, HC-49/S	250892-001	
CF401	RESNTR, CER, W/INTGRD CAPS, 8MHZ	191446-8R00	
CF500	CRYSTAL, 16.9344MHZ, HC-49/S	193415-001	





Inductors

Reference Designator	Description	Part Number	Note
L1, 2	2.2uH, COMMON MODE	187598-2R2	
L3, 4	INDUCTOR, BEAD, FORMED, 17.5MM	170179	
L300, 400, 401, 402, 403, 404	INDUCTOR, CHIP, 0805, 400Ω	188587-401	

Tuning Coils

Reference Designator	Description	Part Number	Note
T300	DETECTOR, FM, SINGLE TUNED	187602-001	
T301	FILTER, CER, AM IF	187603-001	
T302	COIL, OSCILLATOR, AM	180647	
T303, 304	FILTER, STEREO MPX, SINGLE TUNED	187624-001	

Miscellaneous

Reference Designator	Description	Part Number	Note
F1	FUSE, 0.75A, 250V	135677-04	
VFD	DISPLAY, VACUUM FLUOR, 4-GRID	193413	
FM-TUNER	TUNER, FM, 3GANG, 7V	180995	
FOR-D401	SPACER, LED	193426	
FOR-Q401	SPACER, LED	193426	
FOR-U300	SHIELD, IC, BWR	178944	
J1	CONN, HEADER, LOCKING, TOP ENTRY	193369-002	
J2	CONN, HEADER, 5.0MM, 5A, 2PIN	191946-002	
J3	CONN, HEADER, 8POS	148591-08	
J5, 6	CONN, HEADER, PCBMNT, 2POS	193422-002	

ELECTRICAL PART LIST

Miscellaneous (continued)

Reference Designator	Description	Part Number	Note
J200	CABLE, BATTERY/ADAPTER, 9 VOLT	187610-001	
J300	CONN, FM ANTENNA, F- TYPE	193453	
J301, 401, 402, 501	CONN, HEADER, RTANG, 21PIN, FCC	191169-21	
J400	CONN, HEADER, 3POS	148591-03	
J403	CONN, HEADER, RTANG, 15PIN, WHITE	191169-15	
J500	CONN, HEADER, 13P, TOP-ENTRY, ZIF	193368-013	
J502	HEADER, LOW CURRENT 6 POLE	133224-06	
J600	CONN, HOUSING, PHONO, QUAD	149959	
AM-ANT	ANTENNA, FERRITE BAR, AM, BWR	177268-WRCD	
	SCREW, TAPP, M3.5x0.6x10, PAN, TRX	140447-10	
	CLIP, SPRING	142864	
	HEATSINK	177562	
	HOLDER, VFD, WRCD	199955	
	SHIELD, BOTTOM, DISPLAY PCB	198610	

PACKAGING PART LIST

Item Number	Description	Part Number	Note
1	CARTON, RSC, WRCD/BWR	199479-001	
2	PACKING, THERMOTRAY, TOP	250843	
3	PACKING, THERMOTRAY, BOTTOM	250844	
-	PACKING INSERT	199476	
-	REMOTE, CDWR, WHITE	193334-001	
-	REMOTE, CDWR, GRAPHITE GRAY	193334-002	
-	REMOTE, CDWR, PLATINUM WHITE	193334-010	
-	BATTERY, LITHIUM, 2032	180991	⚠ ³
-	BATTERY, CARBON, 9 VOLT	187609-001	⚠ ³
-	VELCRO, HOOK AND LOOP, MATED	188463-001	
-	MANUAL, OWNER'S	193337	
-	SHEET, QUICKSTART, 110V	193338	
-	CD, DEMO, US	193340	
-	ALL PRODUCTS BROCHURE	188898	
-	WARRANTY CARD, ENGLISH	193408	
-	SLIP SHEET	199914	

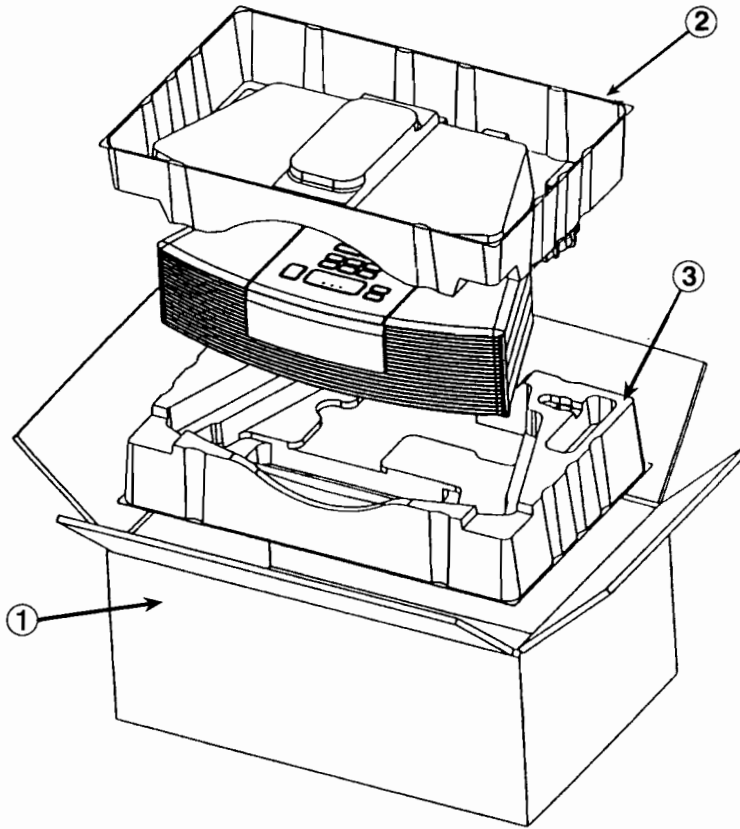

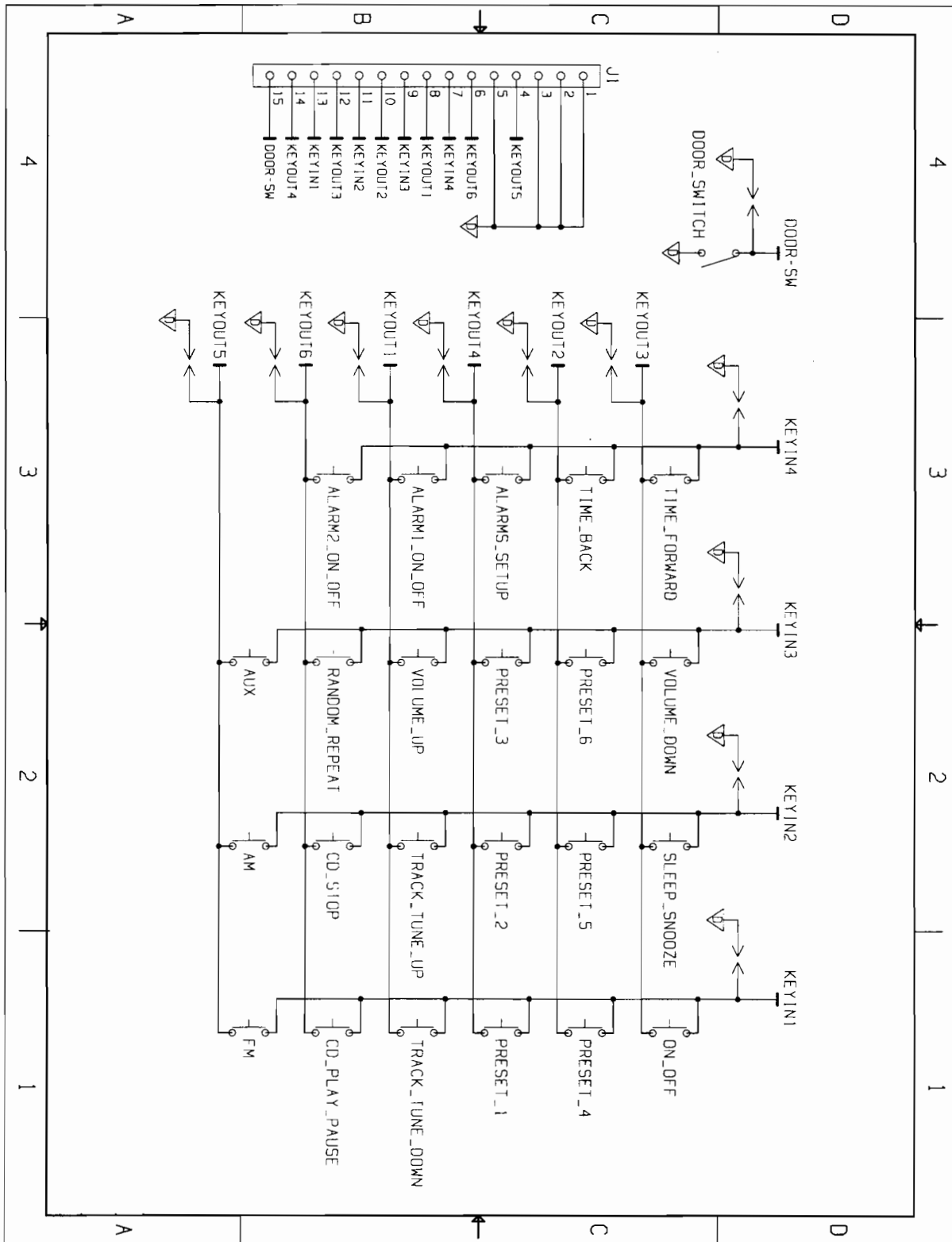

Figure 4. Keyboard Schematic Diagram

ABBREVIATED OPERATING INSTRUCTIONS

Note: Refer to the Bose® Wave® Radio/CD Owner's Guide 193337 for complete operating instructions.

To turn off the display- With the system off, hold down **CD Mode** and press **On/Off** to turn off the main display. The display only lights briefly when you press any button and while the alarm is sounding. Repeat this step to turn the main display back on.

To set AM/PM (12 hour) or Military (24 hour) time- With the system off, hold down **Alarm Setup** and press **On/Off** to switch between AM/PM (12 hour) and Military (24 hour) time formats.

To adjust the display brightness- The display dims automatically to medium or low brightness, as appropriate for low light room conditions. You can adjust the brightness setting of the display for both strong light and lowest light environments, but not for the medium light setting (9). Turn the system off before setting the brightness levels.

- In a strongly lit room, hold down **CD Mode** and press **Volume up or down** to adjust the setting between 9 and 13 (it is preset to 11).
- In a barely lit room, hold down **CD Mode** and press **Volume up or down** to adjust the setting between 1 and 9 (it is preset to 2).
- If you do not want the system to dim automatically, set both levels to 9.

To manually tune in a station- Tap either **Track/Tune** button quickly two or more times to tune to the frequency in small steps or, press and hold either **Track/Tune** button until the desired station is reached. Then, you can press the button to adjust the frequency in small steps. After manually tuning, wait two seconds for the system to return to seek mode.

To set the alarm volume- While the selected alarm is flashing, press **Volume up or down** to set the alarm volume, from **10** to **99**. The selected alarm flashes for ten seconds.

To set continuous music- To select a source to play automatically after the CD ends, hold down **Alarm Setup** and press **FM, AM, or AUX** on the control panel only. The selected source lights briefly on the display.

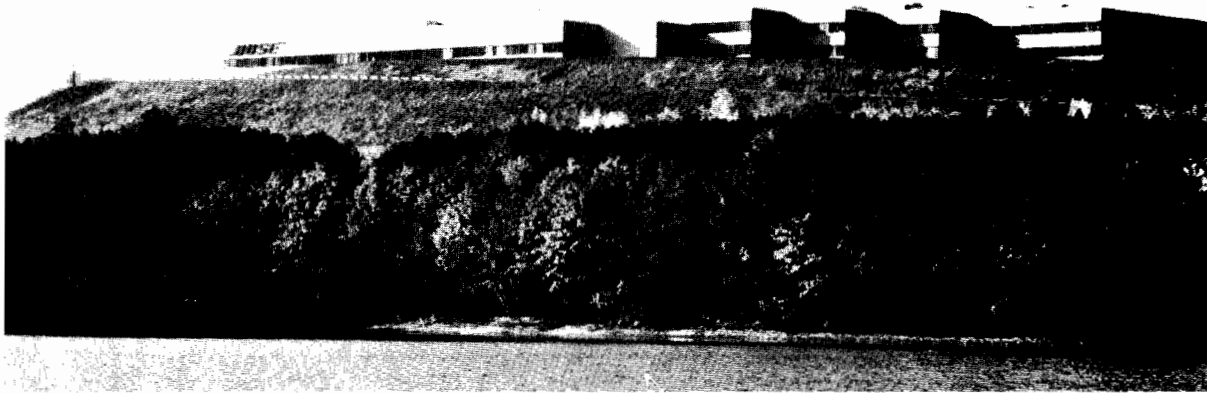

SPECIFICATIONS AND FEATURES SUBJECT TO CHANGE WITHOUT NOTICE

BOSE[®]
Better sound through research.

Bose Corporation
The Mountain
Framingham Massachusetts USA 01701



P/N: 250443 REV. 00 2/99 FOR TECHNICAL ASSISTANCE OR PART ORDERS, CALL 1-800-367-4008

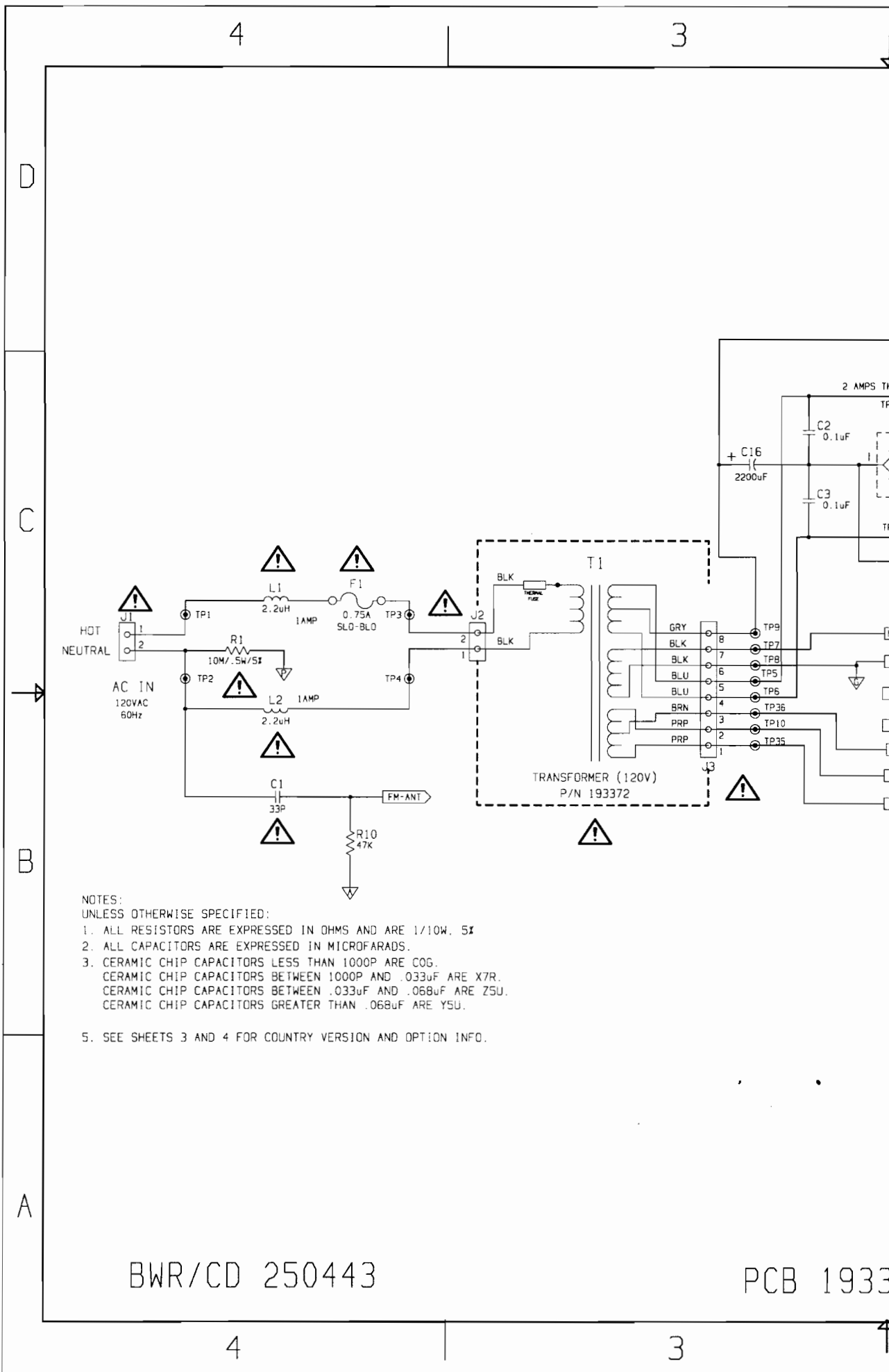

- NOTES:
UNLESS OTHERWISE SPECIFIED:
1. ALL RESISTORS ARE EXPRESSED IN OHMS AND ARE 1/10W, 5%
 2. ALL CAPACITORS ARE EXPRESSED IN MICROFARADS.
 3. CERAMIC CHIP CAPACITORS LESS THAN 1000P ARE COG.
CERAMIC CHIP CAPACITORS BETWEEN 1000P AND .033uF ARE X7R.
CERAMIC CHIP CAPACITORS BETWEEN .033uF AND .068uF ARE Z5U.
CERAMIC CHIP CAPACITORS GREATER THAN .068uF ARE Y5U.
 5. SEE SHEETS 3 AND 4 FOR COUNTRY VERSION AND OPTION INFO.

BWR/CD 250443

PCB 1933

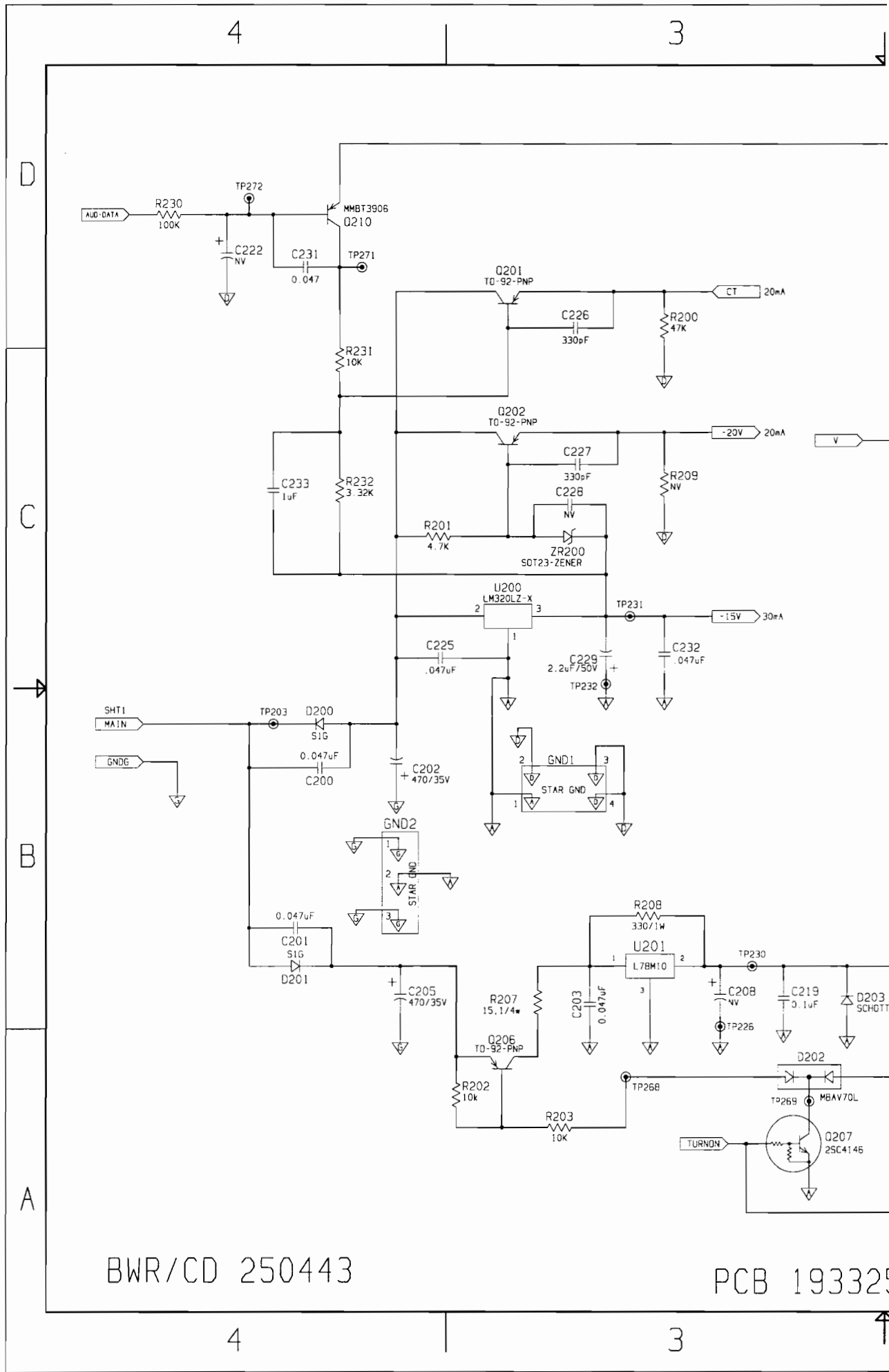

BWR/CD 250443

PCB 193329

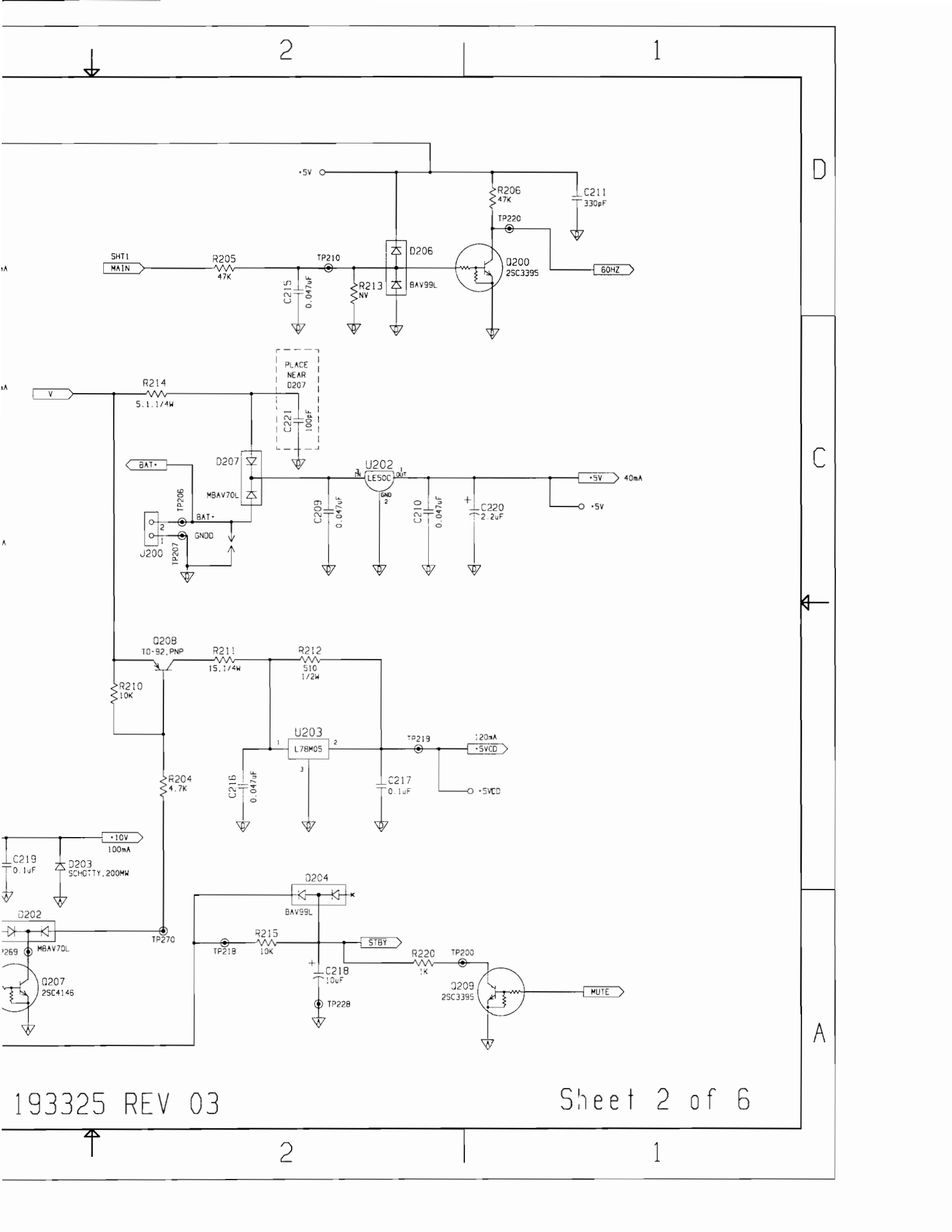

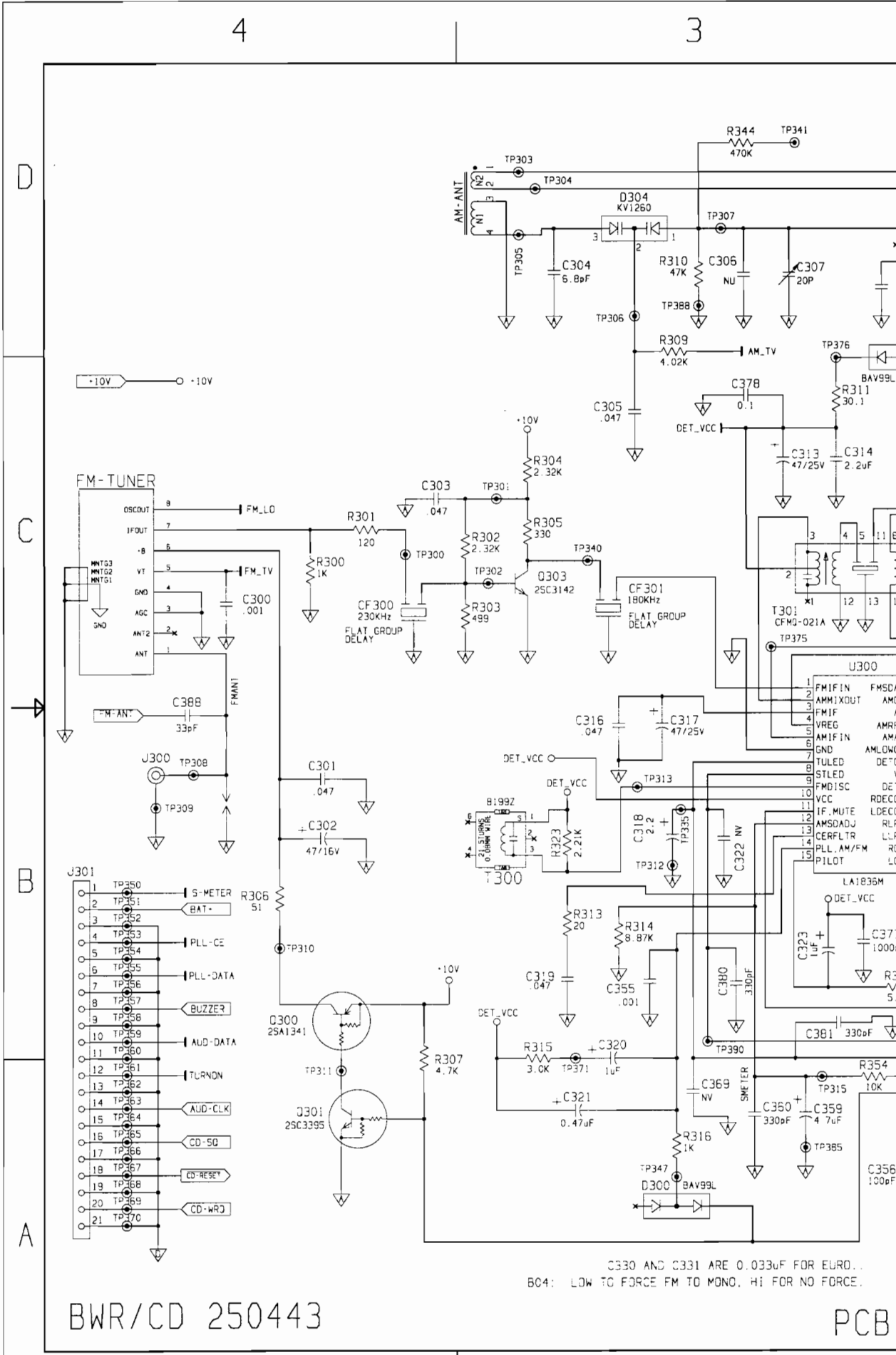

C330 AND C331 ARE 0.033uF FOR EURO...
 B04: LOW TO FORCE FM TO MONO, HI FOR NO FORCE.

BWR/CD 250443

PCB

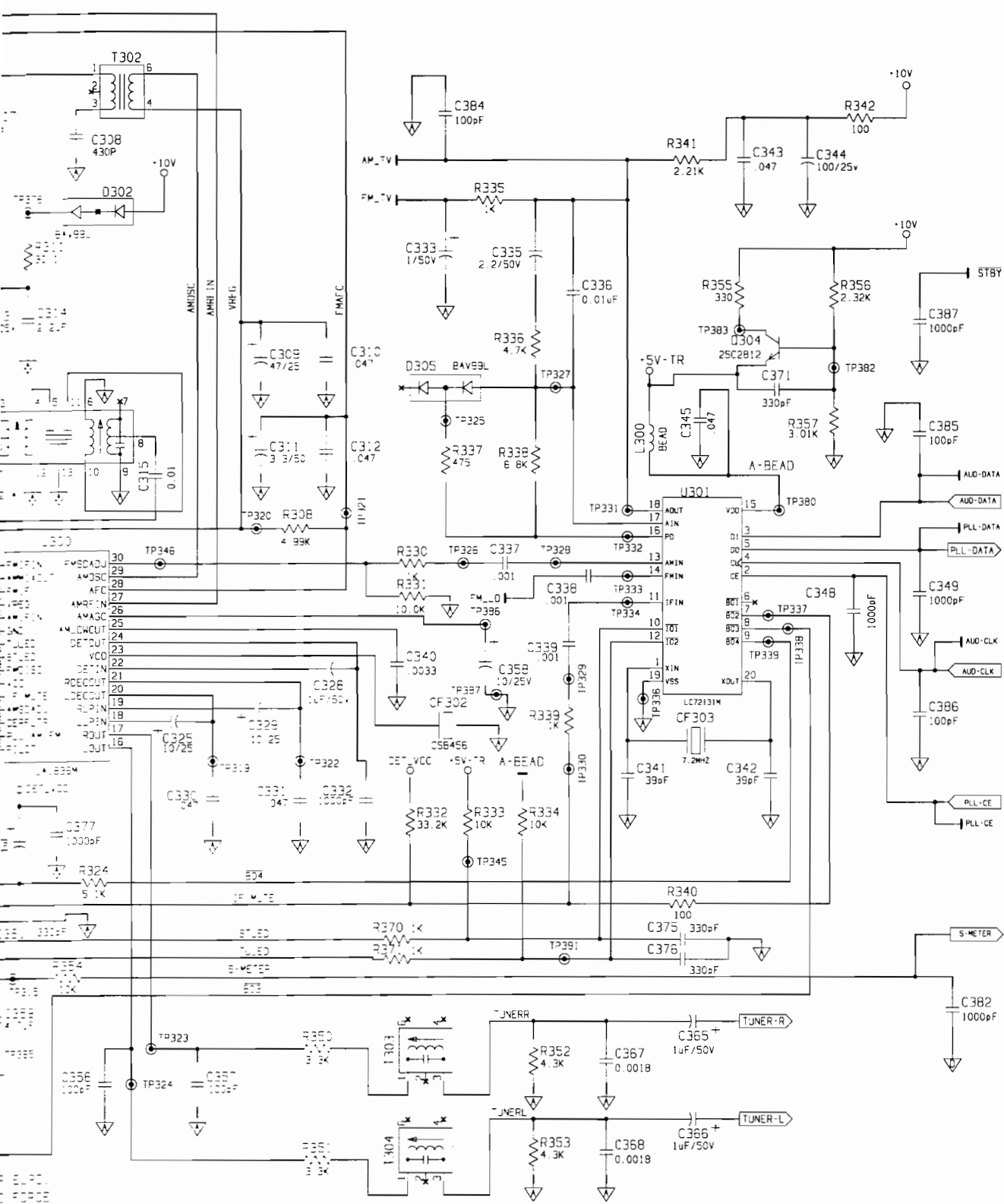

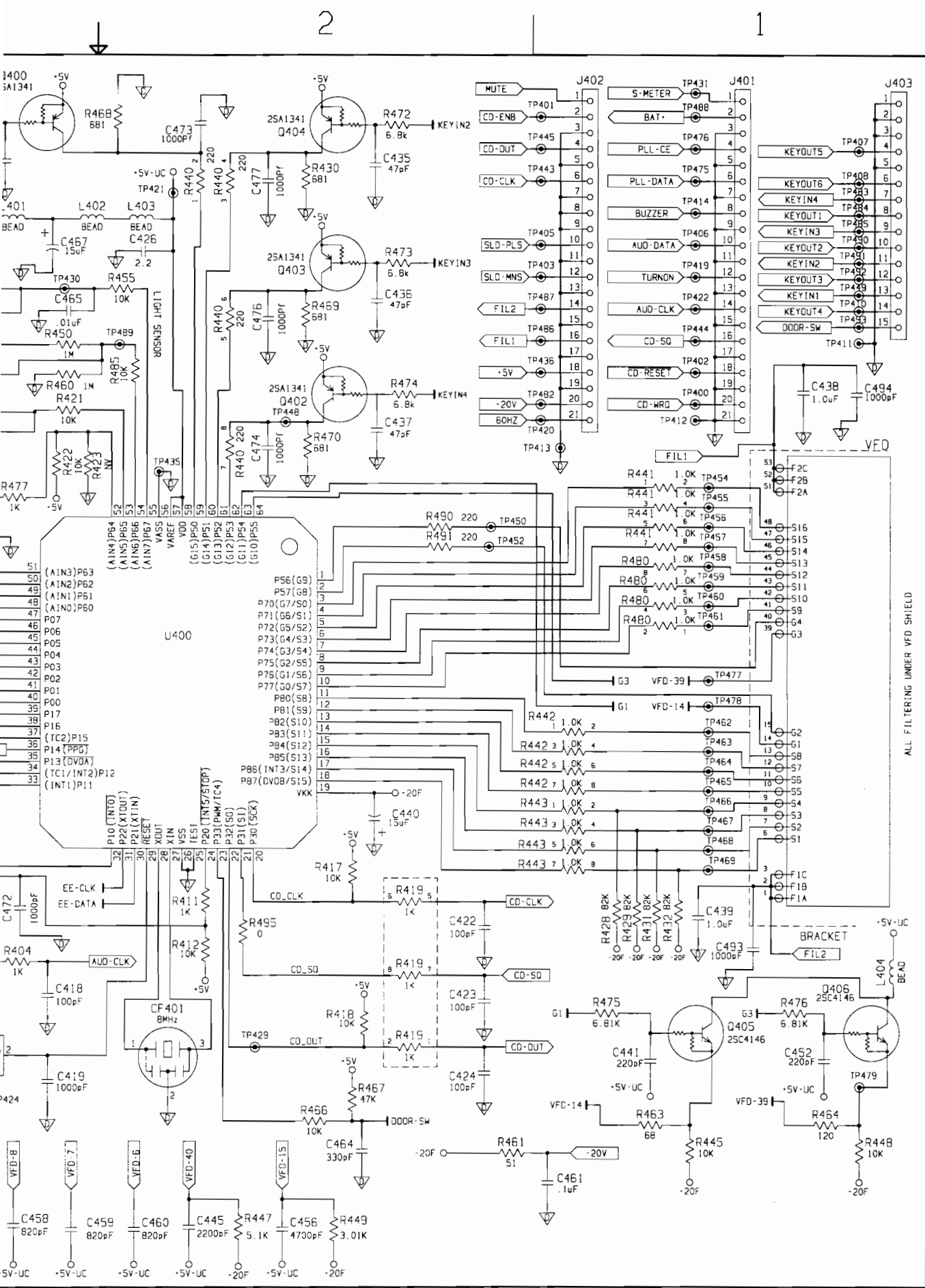

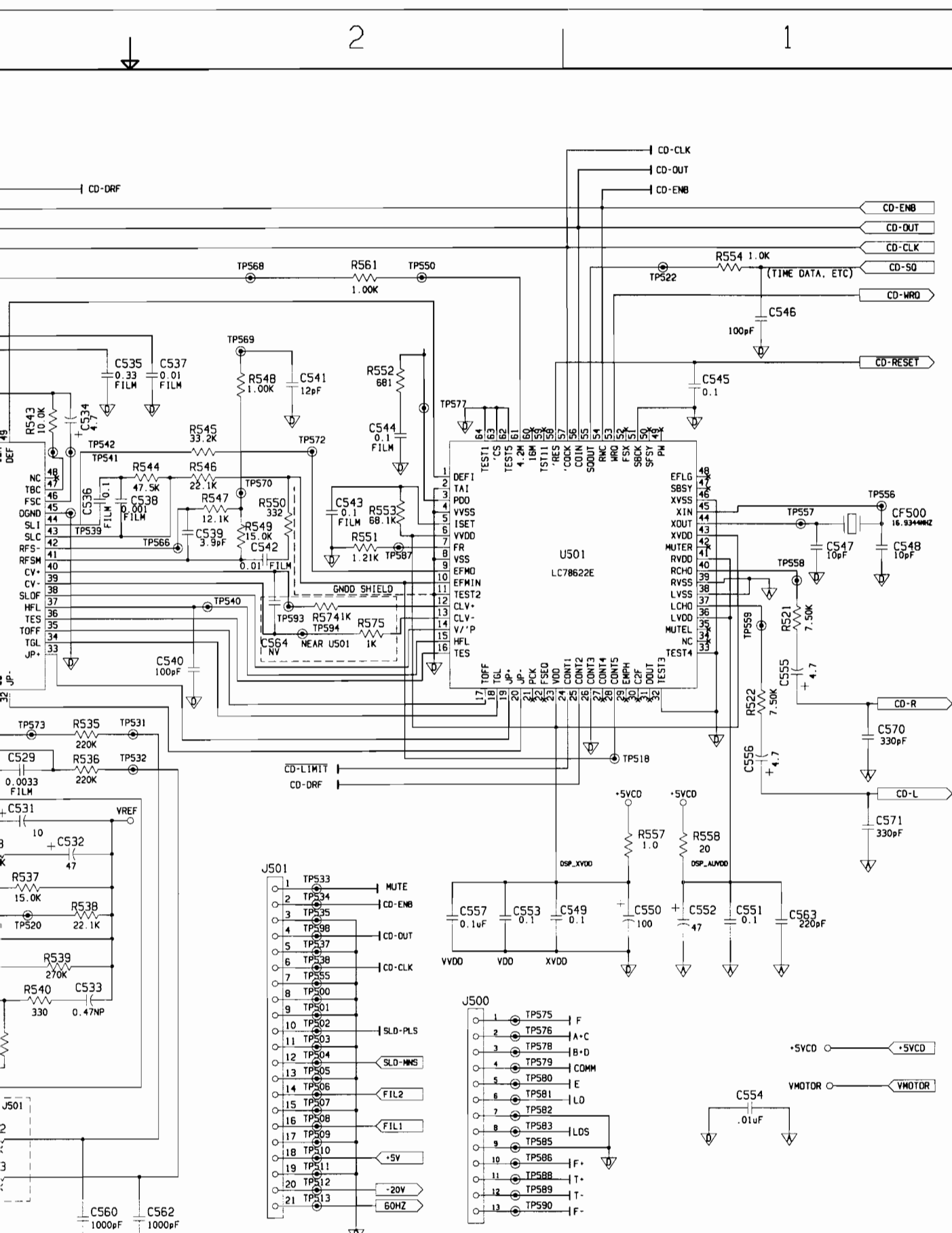

PCB 193325 REV 03

Sheet 5 of 6

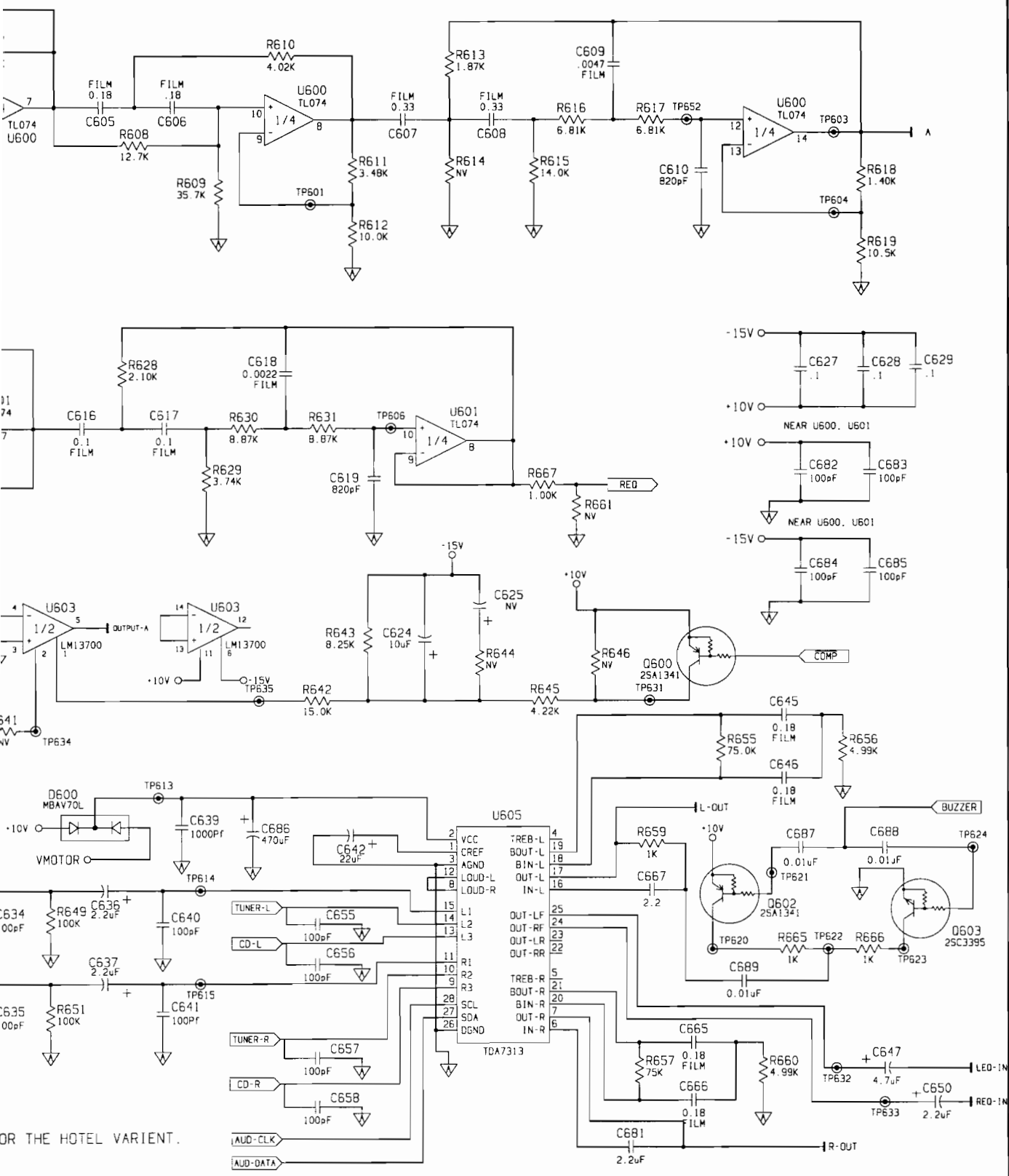

FOR THE HOTEL VARIANT.



SERVICE BULLETIN

Product Bose® Wave® Radio/CD

250443-B1

Subject Display Not Working Properly

Effective Date All Units

S/N

Symptom: No display, or all segments of the display illuminate with ghosting, or the display has unusual dim/bright behaviors.

Reason: Failed Q201 and/or Q202; intermittent transformer shorts.

Solution: Replace Q201 and Q202 part number 119168 and only power the PCBs with both ribbon cables fully inserted. Replace the transformer if it is a rev 02 (with a date code before 01/99), a rev 01 or a rev 00.

If the two ribbon cables that attach the display PCB to the main PCB are removed or attached while the main PCB has power applied to it, Q201 and/or Q202 could fail causing the display not to work properly. Do not apply power to the PCB without the two ribbon cables, which attach the display PCB to the main PCB, fully inserted. Located on the transformer is a label with the part number and revision number. Replace the transformer if it is a rev 02 (with a date code before 01/99), a rev 01 or a rev 00. There is a potential for a short in the secondary of these transformers which could cause Q201 and/or Q202 to fail. The short can be intermittent. Refer to the diagrams on the back of this page for the location of Q201, Q202 and the location of the transformer's rev and date code. Refer to the BWR/CD service manual part number 250443 for further service information.

Date Issued: 5/99

FRACAS 222

Bose Corporation
The Mountain
Framingham, MA 01701-9168

For Technical Assistance Call 1-800-367-4008

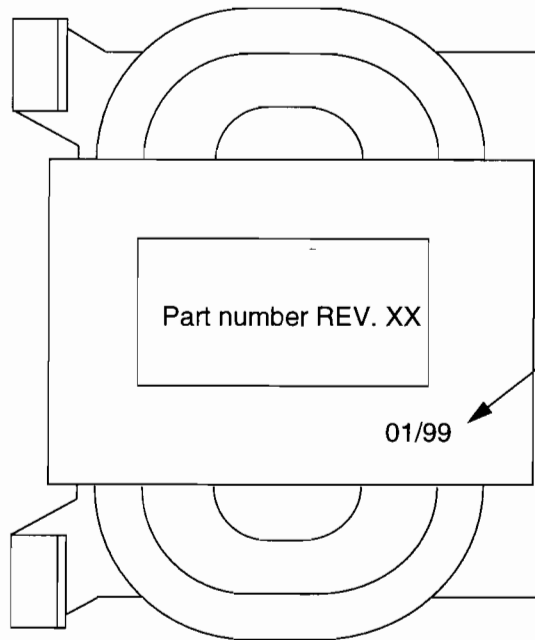
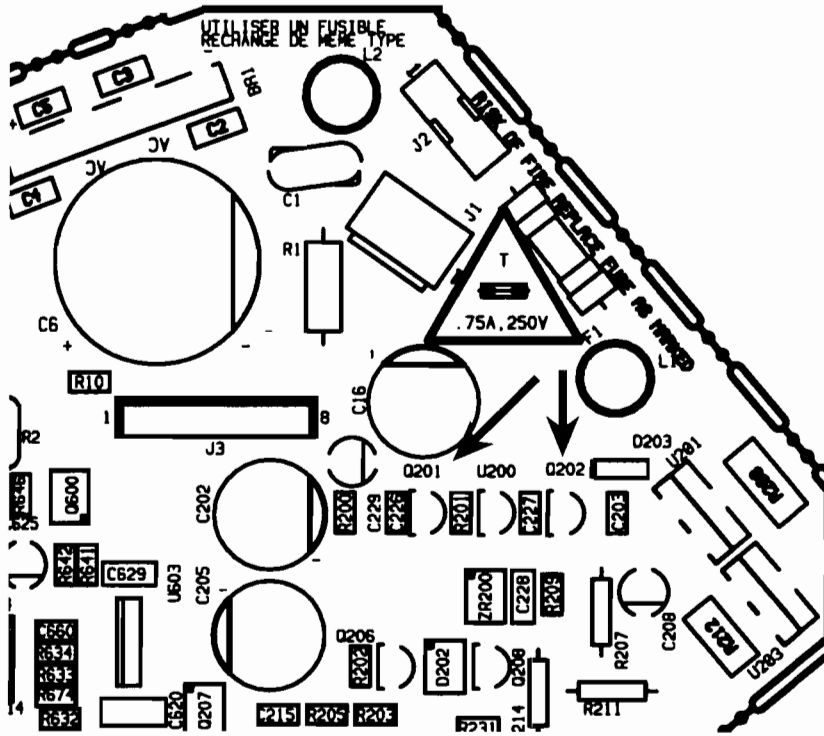
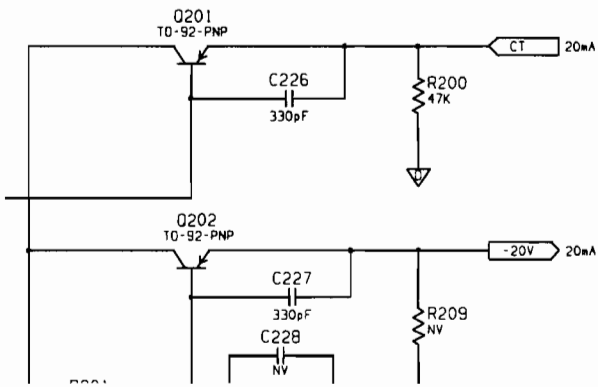

The first two numbers of the date code are the week of the year and the last two numbers are the year.

Date code stamp
week/year

01/99 is the first week of 1999.

Side View



SERVICE BULLETIN

Product Bose® Wave® Radio/CD

250443-B2

Subject Noisy CD Mechanism

Effective Date Units manufactured before 4/19/99

S/N

Symptom: A customer complains that the CD player is noisy.

Reason: The high frequency gain in the track, focus and spin loops is too high.

Solution: Replace the components listed below.

Reduce the high frequency gain of the track, focus and spin loops by changing the value of the components listed below. C559 was not used in earlier manufactured units. There is a place for it so it can be easily added. Refer to the diagrams on the back of this page for the location of the parts listed below. Refer to the Bose Wave Radio/CD service manual 250443 for further service information.

Reference Designator	Description	Part Number
C506	.033uF, BOX, 85, 63V, 5%	137127-333
C508	.0068uF, BOX, 85, 100V, 5%	137127-682
C559	.047uF, 0805, X7R, 50V, 10%	133623-473
C514	.01uF, BOX, 85, 100V, 5%	137127-103
R531	2.21K, CHIP, 0805, 1/10W, 1%	133625-2211
R555	7.50K, 0805, 1/10W, 1%	133625-7501
R571	7.50K, 0805, 1/10W, 1%	133625-7501

Date Issued: 5/99

FRACAS 235

Bose Corporation
The Mountain
Framingham, MA 01701-9168

For Technical Assistance Call 1-800-367-4008

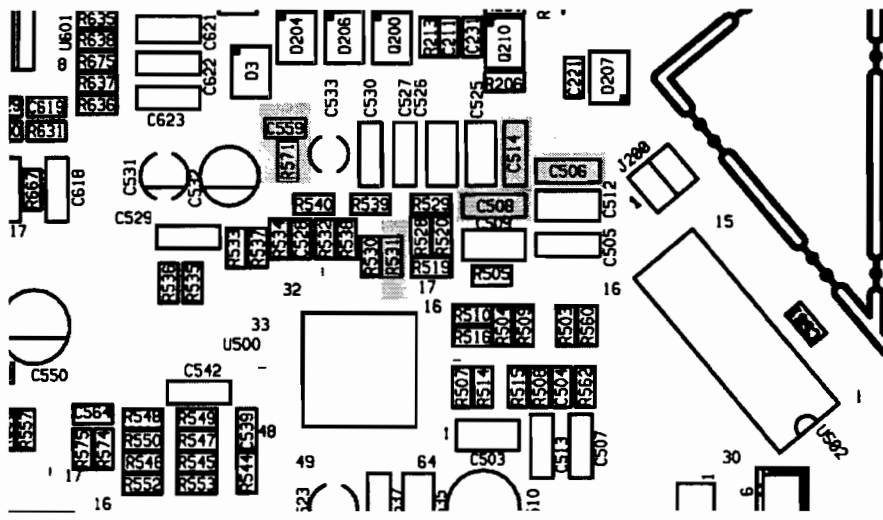

Top Side Layout

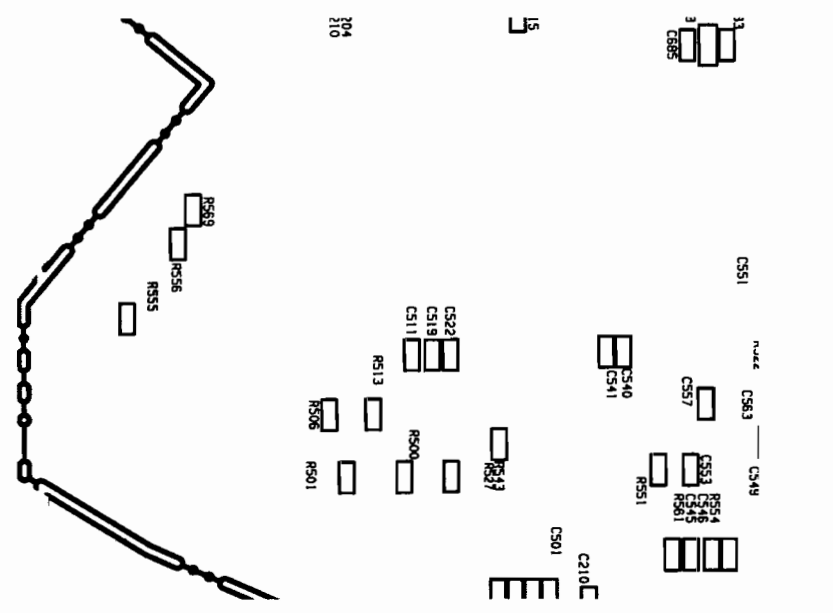

Bottom Side Layout

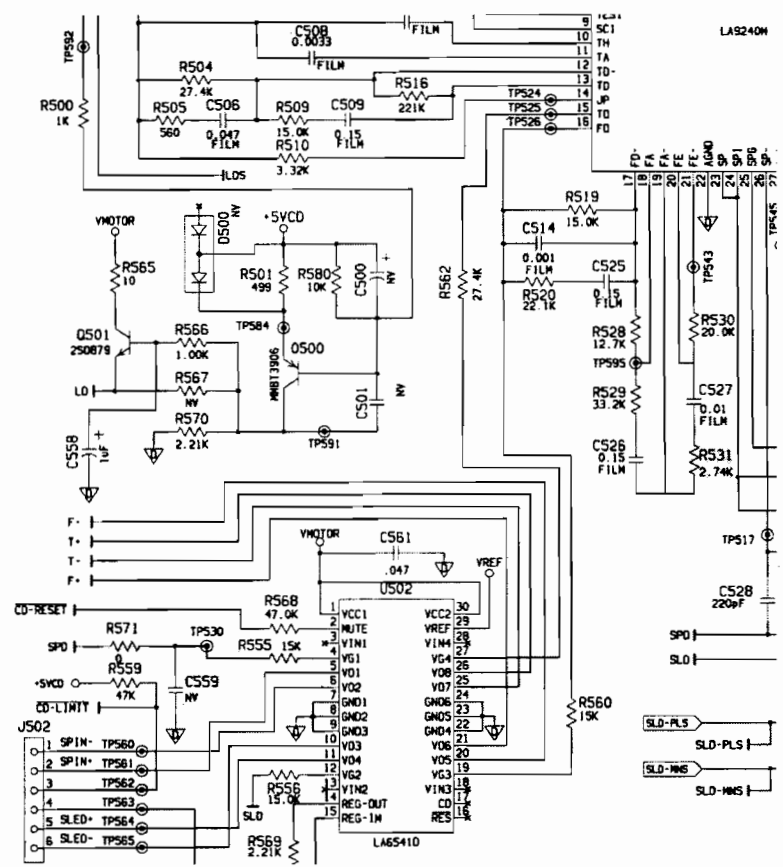

**BOSE**

SERVICE BULLETIN

Product Bose® Wave® Radio/CD

250443-B3

Subject Intermittent/inoperable FM/AM section.

Effective Date All units.

S/N

Symptom: The FM/AM section is intermittent or does not operate.

Reason: CF303 has fractured solder joints and/or has failed.

Solution: Replace CF303, C341 and C342.

The crystal CF303 used in units manufactured before 5/4/99 can fail because of a defective lot of crystals or because of the values used for capacitors C341 and C342. In units manufactured before 5/4/99, replace CF303 with 7.2 MHz crystal 250892-001 and C341 and C342 with 27pf capacitors 133622-270. After soldering CF303, be sure to clip the leads. Located under CF303 on the black plastic base is a small protruding object. If the leads of CF303 are not clipped, the leads can be pushed by the protruding object and cause the solder joint to fracture.

If a unit is returned with an intermittent or inoperable FM/AM section and the D.O.M is after 5/4/99, check for fractured solder joints on CF303 and make sure the leads have been clipped.

Refer to the layout and the schematic on the back of this page for the location of CF303, C341 and C342. Refer to the BWR/CD service manual 250443 for further service information.

The date of manufacture (D.O.M.) is located on the underside of the unit. The first two digits are the year, the second two digits are the month and the last two digits are the day. 5/4/99 would be 990504.

FRACAS 245

Date Issued: 5/99

Bose Corporation
The Mountain
Framingham, MA 01701-9168

For Technical Assistance Call 1-800-367-4008

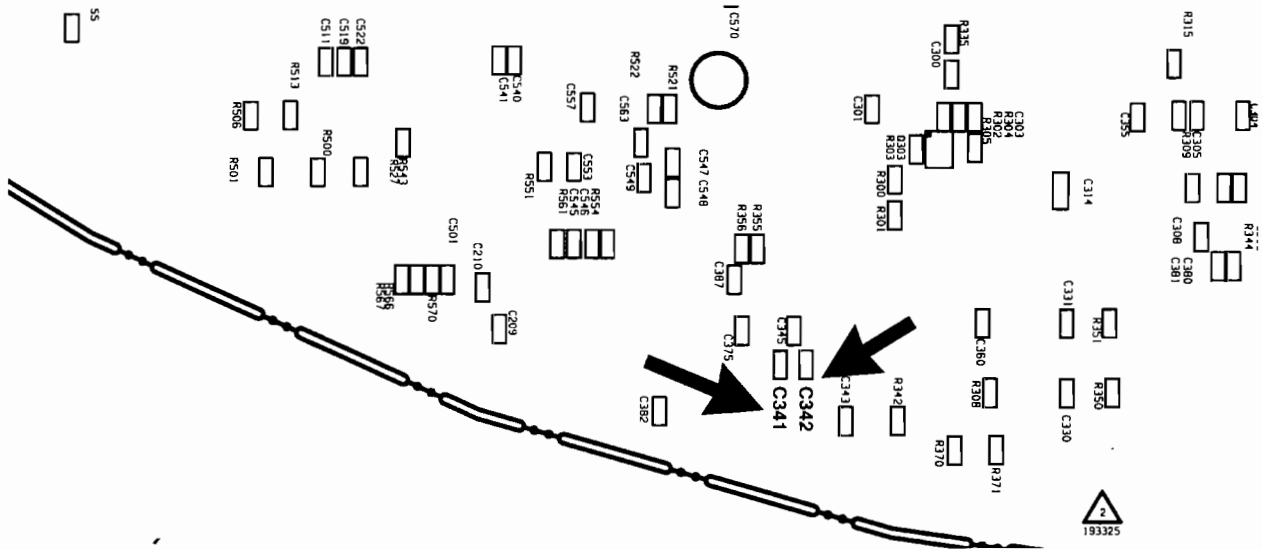

Bottom Side Layout

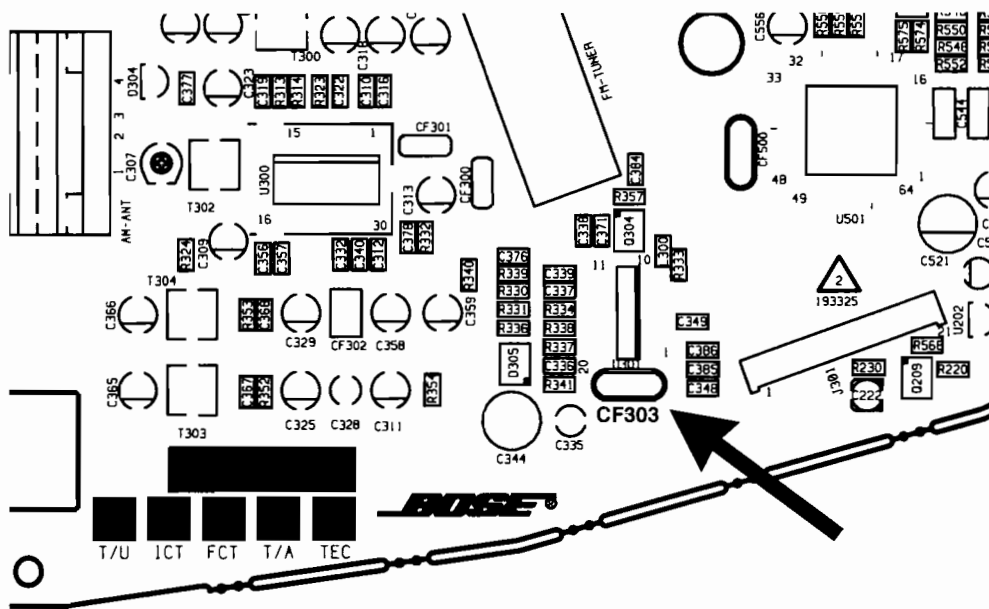

Top Side Layout

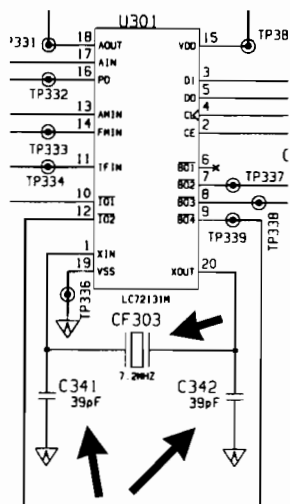

BOSE[®] WAVE[®] RADIO/CD TROUBLESHOOTING GUIDE

Refer to the Bose Wave radio/CD service manual, part number 250443, for schematics, PCB layouts and part lists.

Symptom	Reason(s)	Action
Dead Unit.	<ol style="list-style-type: none"> 1. Fuse F1 open. 2. Unseated J1. 3. Open power transformer. 	<ol style="list-style-type: none"> 1. Replace fuse F1. 2. Reconnect J1. 3. Replace power transformer.
Unit turns on/off by itself.	CD door defective.	Replace the CD door assembly.
Intermittent or inoperable FM/AM.	<p>Depending on date code, defective CF303 and C341, C342 or fractured solder joints on CF303.</p> <p>Refer to service bulletin 250443-B3 for further information.</p>	<ol style="list-style-type: none"> 1. In units built before 5/4/99, replace CF303 with a 7.2 MHz crystal, part number 250892-001 and C341 and C342 with 27pF capacitors part number 133622-270. After soldering CF303, be sure to clip the leads. 2. In units built after 5/4/99, check for fractured solder joints on CF303 and make sure the leads have been clipped.
Constant hum on AM/FM.	Power supply capacitor C205 may be installed with reverse polarity.	Replace capacitor C205 part number 144000-471V.
Hum on all sources.	Reversed C202 or C205.	Replace C202 or C205.
The CD player is inoperable or intermittent.	Fractured solder joints on power supply capacitor C16.	Re-solder power supply capacitor C16.
The unit doesn't respond to the buttons located on the CD door. CD does not work.	<p>The PCB located in the CD door assembly may be cracked.</p> <ol style="list-style-type: none"> 1. CD mechanism lens dirty. 2. C16 has fractured solder joints 3. 13 conductor flex cable defective. 4. CD mechanism failed. 5. U500 defective. 6. Switch on CD door assembly defective. 	<p>Replace the CD door assembly, part number 198608-010 platinum white or 198608-002 graphite grey.</p> <ol style="list-style-type: none"> 1. Clean lens. 2. Resolder C16. 3. Replace the flex cable. 4. Replace the CD mechanism. 5. Replace U500. 6. Replace the CD door assembly.
CD skips.	<ol style="list-style-type: none"> 1. C16 has fractured solder joints 2. 13 conductor flex cable defective. 	<ol style="list-style-type: none"> 1. Resolder C16. 2. Replace the flex cable.



TECH TIPS

Solutions to problems we occasionally see on the repair bench.

PRODUCT: Bose® Wave® Radio/CD. Service Manual part number 250443.



*Peter Cortese
Electronic Technician*

Intermittent or inoperable FM/AM operation in the BWR/CD can be caused by crystal CF303 failing. The crystal CF303 used in units manufactured before 5/4/99 can fail because of a defective lot of crystals or because of the values used for ca-

pacitors C341 and C342.

In units manufactured before 5/4/99, replace CF303 with a 7.2 Mhz crystal part number 250892-001 and C341 and C342 with 27pf capacitors part number 133622-270. After soldering CF303, be sure to clip the leads. Located under CF303 on the black plastic base is a small protruding object. If the leads of CF303 are not clipped, the leads can be pushed by the protruding object and cause the solder joint to fracture.

If a unit is returned with an intermittent or inoperable FM/AM section and the D.O.M is after 5/4/99, check for fractured solder joints on CF303 and make sure the leads have been clipped.

The date of manufacture (D.O.M.) is located on the underside of the unit. The first two digits are the year, the second two digits are the month and the last two digits are the day. 5/4/99 would be 990504.

Refer to the service bulletin 250443-B3 and the BWR/CD service manual 250443 for further service information.

Here are some other problems that we occasionally see with the BWR/CD;

Symptom: The CD player is inoperable or intermittent.

Reason: Fractured solder joints on the power supply capacitor C16.

Solution: Re-solder capacitor C16.

Symptom: The unit doesn't respond to the buttons located on the CD door.

Reason: The PCB located in the CD door assembly maybe cracked.

Solution: Replace the CD door assembly, part number 198608-010 platinum white, 198608-002 graphite grey.

Symptom: Constant hum on AM/FM

Reason: Power Supply capacitor C205 might be installed with reverse polarity.

Solution: Replace capacitor C205 part number 144000-471V.



Bose Wave Radio/CD

BOTTOM SIDE

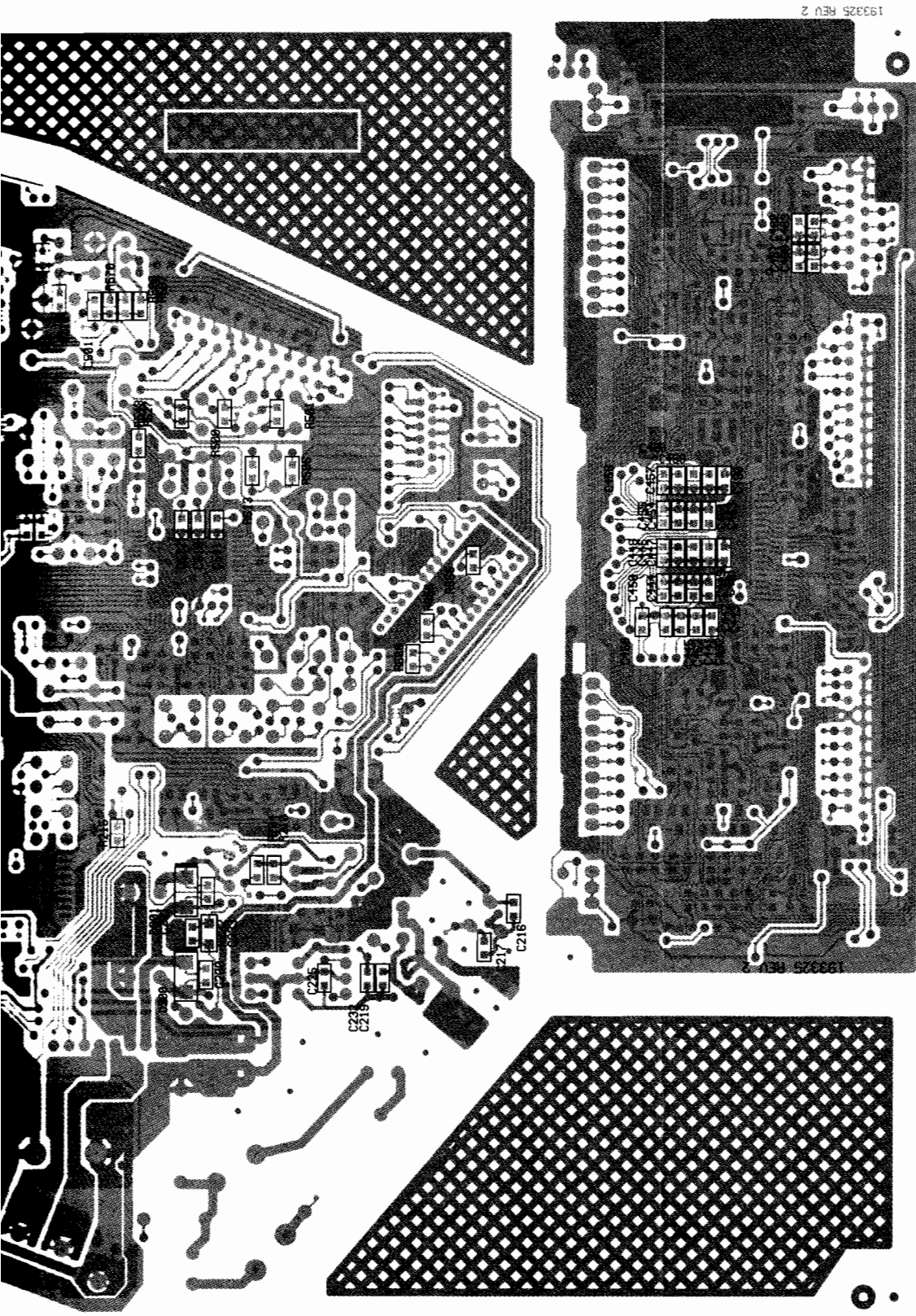

193325 REV 2

193325 REV 2

C216

C217

C218

DE LAYOUT

UTILISE UN FUSIBLE
MECHANGE DE REPE TYPE

