



BOSE WAVE® RADIO I, II, III TROUBLE SHOOTING GUIDE

Refer to the Bose Wave Radio service manuals, part numbers 174784, 181811 and 191514, for schematics, PCB layouts and part list. Unit identification: BWR I: 3 AA battery backup, has AM external antenna. BWR II: 3 AA battery backup, no AM external antenna. BWR III: 9V battery backup.

Symptom	Check
Intermittent Operation:	<ol style="list-style-type: none"> 1: Check for fractured solder joints on AC connector J111, (BWR I and II) J1 (BWR III). 2: BWR I: Check for fractured solder joints at interconnects between display and main PCB. Check for fractured or cold solder joints on U302 and U301.
Unit inoperative:	<ol style="list-style-type: none"> 1: Check for open fuse, F1 2: Check for open at L1 3: Check for fractured solder joints on AC connector J111. 4: Check R406 for open. Replace with 1 Ohm, 1/2W fusible resistor, part number 188460-1R0. See Service Bulletin 181811-B2. 5: BWR II and III: Check Q4. Replace with part number 140348. Service Bulletin 191514-B5 6. Popping sound when unplugged: Check transistor Q401, 5V supply for display.
Remote control does not work or does not work in some locations:	<ol style="list-style-type: none"> 1: Check IR sensor 2: Fluorescent lighting Interference might be the cause. Replace the IR sensor with IR sensor part number 187205. Connect a 1uf capacitor, part number 149948-1R0H, across R407. Connect the positive side of the cap to the base of Q401 and the negative side to the ground side of R407. See Service Bulletin 174784-B4. 3: Check remote and remote batteries.
Volume goes to 99 when the customer uses the remote at high volume:	<p>BWR II : Place a 1uf capacitor, 149948-1R0H, in parallel with R407. See Service Bulletin 174784-B3.</p> <p>BWR III: Place a 2.2uf capacitor, part number 178212-225, in parallel with R13. See Service Bulletin 191514-B1.</p>
Poor FM reception when connected to cable:	<ol style="list-style-type: none"> 1: Check for fractured solder joint on F connector J109. 2: Remove C2 to disconnect the power cord from the front end. The power cord is used as an antenna. When connected to cable, there are two paths for the signal that is fed to the front end. This can cause interference. See Service Bulletin 174784-B2.
No or poor FM:	<ol style="list-style-type: none"> 1: BWR I and II: Check X101. BWR III: Check X600. 2: BWR I and II: Check Q111. 3: Align front end, see service manual for procedures. 4: Low FM volume: Check voltage at Q103, Q104. Should be 12V on pin 2, 4V on pins 1 and 3.
Poor AM Reception:	<ol style="list-style-type: none"> 1: Could be caused by dimmer switch connected to the same circuit. Remove C6 for US versions and C3 for European versions. See Service Bulletin 181811-B1. 2: BWR 1 and II: In some units the PLL has low stability margins. Remove C131, change R138 to 22 Ohm, Change R156 to 3.9k Ohm. See Service Bulletin 174784-B1. 3: BWR II and III: Fractured solder joints on internal AM antenna
Too much bass or distortion at low listening levels:	<p>BWR I: If R989 is 2k Ohm, change R985 to 4k Ohm. If R989 is 1.02k Ohm, change R985 to 2k Ohm. This change will only be noticeable at low listening levels. See Service Bulletin 183886.</p>
Erratic Display:	<p>BWR I: Check for fractured or cold solder joints on U302 and U301.</p> <p>BWR II: R318 might be the wrong value. It should be 15k Ohm. See Service Bulletin 183896.</p>
Hum or buzz when the display dims:	<p>BWR I: On display PCB, change C305 to 1000uF, 50V. Replace jumper Y313 with a 10 Ohm, 1/4W resistor.</p>
Battery backup does not work:	<ol style="list-style-type: none"> 1: BWR I and II: Ensure battery posts are fully inserted into PCB and batteries are fully charged. 2: Check micro, BWR I and II: U301 BWR III: U201
No output after unit has been on for a period of time:	<p>U501 could be going into thermal protection due to the lack of thermal compound on heat sink. Replace U501 if it is a 7374 chip with 7375 chip (part number 180050).</p>
No audio	<p>BWR III: Check for -8V at Q1, check for solder fractures on Aux/lineout connector J-401</p>

Contents

Safety Information	2
Electrostatic Discharge Sensitive (ESDS) Device Handling	3
Specifications	4-6
Figure 1. Twiddler™ Frequency Response Graph	6
Figure 2. Full Range Frequency Response Graph	6
Theory of Operation	7-10
Figure 3. Block Diagram	7
Disassembly/Assembly Procedures	11-12
Test Procedures	13-16
Figure 4. AM Test Setup	14
Part List Notes	16
Main Assembly Part List	17
Figure 5. Exploded View	17
Electrical Part List	18-26
Packaging Part List	27
Figure 6. Packaging View	27
Integrated Circuit Diagrams	28-31

PROPRIETARY INFORMATION

THIS DOCUMENT CONTAINS PROPRIETARY INFORMATION OF BOSE® CORPORATION WHICH IS BEING FURNISHED ONLY FOR THE PURPOSE OF SERVICING THE IDENTIFIED BOSE PRODUCT BY AN AUTHORIZED BOSE SERVICE CENTER OR OWNER OF THE BOSE PRODUCT, AND SHALL NOT BE REPRODUCED OR USED FOR ANY OTHER PURPOSE.

REV 00-01: Changed U401 from 180050 to 250117
REV 01-02: Changed Q4 from 187594-001 to 140348 FRACAS 301
REV 02-03: Added dash variant to Twiddler and fullrange driver
REV 03-04: Change part number for pedestal, ECN 28575

SAFETY INFORMATION

1. Parts that have special safety characteristics are identified by the  symbol on schematics or by special notes in the part lists. Use only replacement parts that have critical characteristics recommended by the manufacturer.
2. Make leakage current or resistance measurements to determine that exposed parts are acceptably insulated from the supply circuit before returning the unit to the customer. Use the following checks to perform these measurements:

A. Leakage Current Hot Check-With the unit completely reassembled, plug the AC line cord directly into a 120V AC outlet. (Do not use an isolation transformer during this test.) Use a leakage current tester or a metering system that complies with American National Standards Institute (ANSI) C101.1 "Leakage Current for Appliances" and Underwriters Laboratories (UL) 1492 (71). With the unit AC switch first in the ON position and then in OFF position, measure from a known earth ground (metal water pipe, conduit, etc.) to all exposed metal parts of the unit (antennas, handle bracket, metal cabinet, screwheads, metallic overlays, control shafts, etc.), especially any exposed metal parts that offer an electrical return path to the chassis. Any current measured must not exceed 0.5 milliamp. Reverse the unit power cord plug in the outlet and repeat test. **ANY MEASUREMENTS NOT WITHIN THE LIMITS SPECIFIED HEREIN INDICATE A POTENTIAL SHOCK HAZARD THAT MUST BE ELIMINATED BEFORE RETURNING THE UNIT TO THE CUSTOMER.**

B. Insulation Resistance Test Cold Check-(1) Unplug the power supply and connect a jumper wire between the two prongs of the plug. (2) Turn on the power switch of the unit. (3) Measure the resistance with an ohmmeter between the jumpered AC plug and each exposed metallic cabinet part on the unit. When the exposed metallic part has a return path to the chassis, the reading should be between 1 and 5.2 Meg ohms. When there is no return path to the chassis, the reading must be "infinite". If it is not within the limits specified, there is the possibility of a shock hazard, and the unit must be repaired and rechecked before it is returned to the customer.

CAUTION: THE BOSE® WAVE® RADIO CONTAINS NO USER SERVICEABLE PARTS. TO PREVENT WARRANTY INFRACTIONS, REFER SERVICING TO WARRANTY SERVICE STATIONS OR FACTORY SERVICE.

Electrostatic Discharge Sensitive (ESDS) Device Handling

This unit contains ESDS devices. We recommend the following precautions when repairing, replacing or transporting ESDS devices:

- Perform work at an electrically grounded work station.
- Wear wrist straps that connect to the station or heel straps that connect to conductive floor mats.
- Avoid touching the leads or contacts of ESDS devices or PC boards even if properly grounded. Handle boards by the edges only.
- Transport or store ESDS devices in ESD protective bags, bins, or totes. Do not insert unprotected devices into materials such as plastic, polystyrene foam, clear plastic bags, bubble wrap or plastic trays.

SPECIFICATIONS

PHYSICAL SPECIFICATIONS

Dimensions:	4 3/16" H x 14" W x 8 1/4" D (35.6 x 21.0 x 10.6 cm)
Weight:	6.8 lbs. (3.1 kg)
Enclosure:	Plastic

FM SPECIFICATIONS

Frequency range:	100 V unit: 76.0-90.0 MHz 120 V unit: 87.5-107.9 MHz 230 V unit: 87.50-108.00 MHz
Channel spacing:	100 V unit: 100 kHz 120 V unit: 200 kHz 230 V unit: 50 kHz
De-emphasis:	120 V unit: 75 μ s 100 V/ 230 V unit: 50 μ s

	Nominal	Limit	Conditions
Usable sensitivity:	14 dBf 16 dBf	19 dBf 21 dBf	C1 Removed C1 Present
50 dB quieting sensitivity			
Mono:	21 dBf	26 dBf	
Stereo:	43 dBf	48 dBf	
Signal to noise ratio			
Mono:	70 dB	65 dB	at 65 dBf
Stereo:	65 dB	60 dB	
Harmonic distortion @ 1 kHz			
Mono:	0.3 %	0.6 %	at 65 dBf
Stereo:	0.6 %	1.0 %	
Capture ratio:	3.0 dB	4.0 dB	
AM rejection:	55 dB	50 dB	at 45 dBf
Adjacent channel selectivity:	15 dB	10 dB	
Alternate channel selectivity:	65 dB	60dB	at 45 dBf
Image rejection:	46 dB	40 dB	
RF intermodulation:	60 dB	55 dB	
Subcarrier product rejection:	45 dB	40 dB	at 65dBf
Frequency response:	\pm 1.0 dB	\pm 3.0 dB	30 Hz-15 KHz
Stereo separation:	30 dB	20 dB	at 1 kHz
Auto stop level:	40 dBf	\pm 5 dB	
Forced mono level:	38 dBf	\pm 5 dB	

SPECIFICATIONS

(Continued)

AM SPECIFICATIONS

Frequency range: 100 V unit: 522-1629 kHz
 120 V unit: 520-1710 kHz
 230 V unit: 522-1611 kHz

Channel spacing: 120 V unit: 10 kHz
 100 V/ 230 V unit: 9 kHz

Test Parameter	Condition	Frequency						
		530-550 kHz	560-590 kHz	600-700 kHz	710-950 kHz	960-1400 kHz	1410-1610 kHz	1620-1710 kHz
Usable sensitivity, dBuV/m (2)		55/63	54/59	51/56	50/55	49/54	48/53	50/55
Adjacent channel selectivity, dB		42/37	42/37	40/35	35/30	35/30	35/30	35/30
Alternate channel selectivity, dB		55/50	55/50	55/50	55/50	55/50	55/50	55/50
Image rejection ratio, dB		45/40	45/40	45/40	45/40	42/37	35/30	35/30
Signal to noise ratio, dB	At 100 dBuV/m	50/40	50/40	50/40	50/40	50/40	50/40	50/40
Distortion, percent	At 100 dBuV/m	0.8/1.4	0.8/1.4	0.8/1.4	0.8/1.4	0.8/1.4	0.8/1.4	0.8/1.4
Frequency response, dB at 50 Hz, 1.8 kHz	At 100 dBuV/m	-3/-6	-3/-6	-3/-6	-3/-6	-3/-6	-3/-6	-3/-6
Auto stop level, dBuV/m		56 ± 7	56 ± 7	56 ± 7	56 ± 7	56 ± 7	56 ± 7	56 ± 7

Note: 1. Nominal/ Limit values.
 2. Using 200Hz audio HPF

SPECIFICATIONS

(Continued)

AUDIO SPECIFICATIONS

Maximum SPL:	=90 dB
Maximum power output (1 kHz, both channels driven):	Full range: 8 W (4 Ω bridged) Twiddler: 4 W (8 Ω bridged)
Total harmonic distortion (1 kHz, full power):	=0.5 % at 80 % of maximum power
Input sensitivity (AUX):	400 mV (for full output, 1kHz)
Input impedance (AUX):	20 k Ω minimum
Speaker output noise:	Maximum volume: =1 mVrms, A-weighted
S/N at line output:	=85 dB
Volume range:	80 dB
Volume increments:	1 dB

GENERAL SPECIFICATIONS

Power consumption:	=8 W with unit switched off =50 W at maximum output
Input line voltage:	120 V, 60 Hz, 50 W 220-240 V, 50Hz, 50 W 100 V 50/60 Hz, 25 W

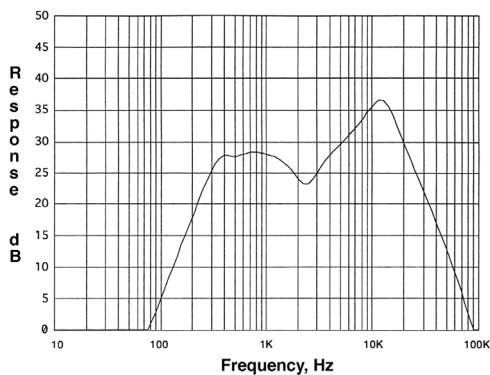

**Figure 1. Twiddler™
Frequency Response Graph**

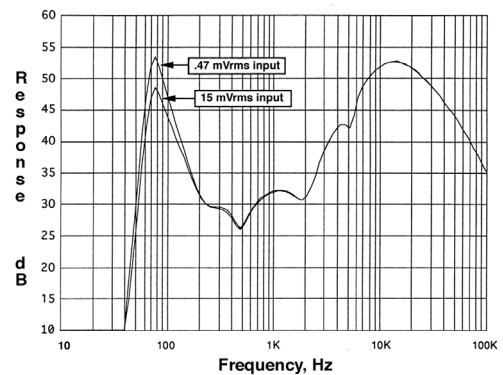

**Figure 2. Full Range
Frequency Response Graph**

THEORY OF OPERATION

Overview

The Bose® Wave® Radio is an AM/FM tuner, preamplifier and powered speaker system. In addition to the tuner, external devices such as a video or CD player can be connected through the unit's AUX input. The unit may also be used as the control unit for Bose powered speaker systems. An infrared (IR) remote control is used to control the unit.

NOTE: The Printed Circuit Board (PCB) assembly is manufactured in one piece. This PCB is broken into two separate assemblies; Display PCB and Main PCB.

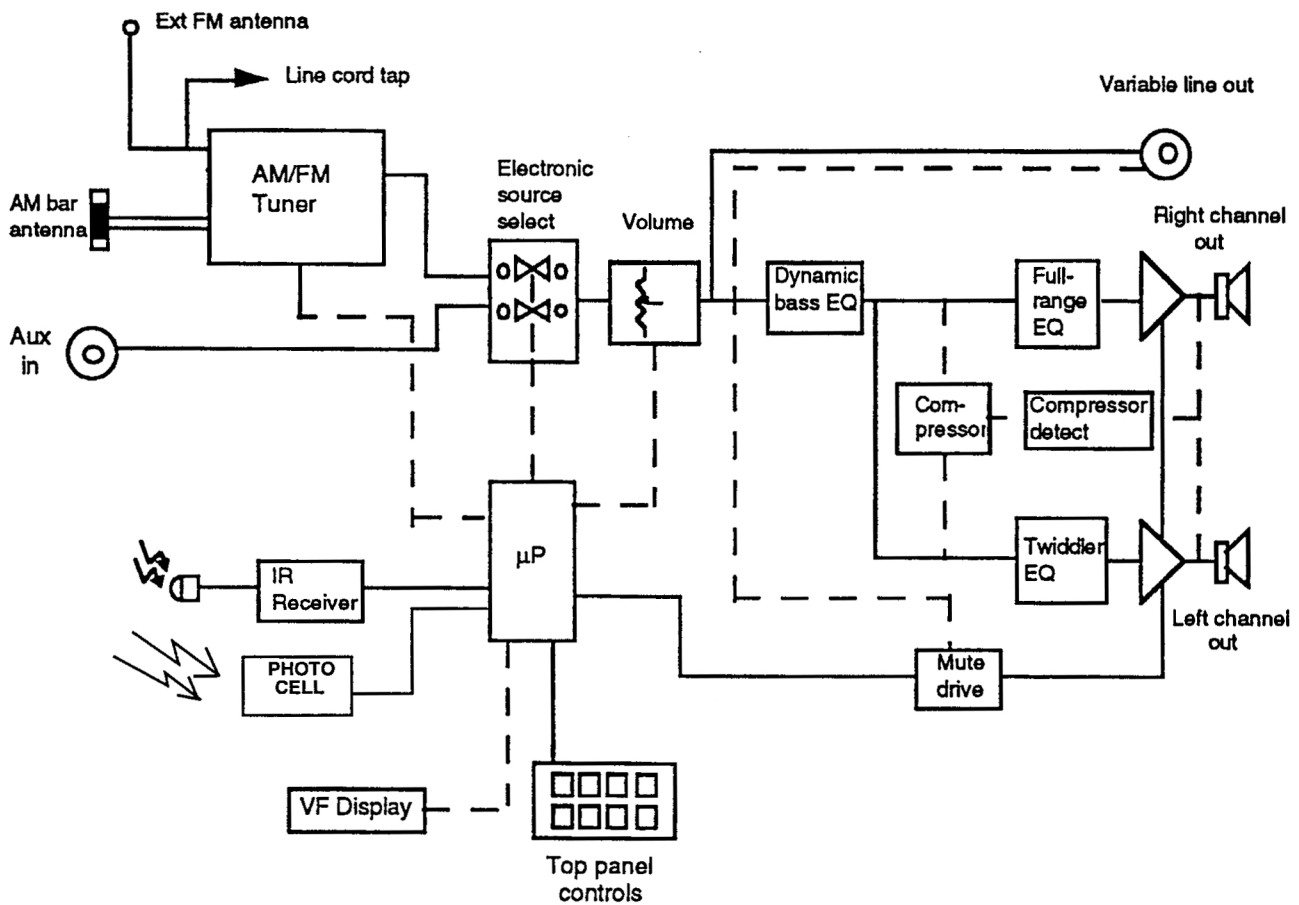

Figure 3. Block Diagram

THEORY OF OPERATION

1. Power Supply

The Bose Wave Radio uses an internal 100, 120 or 220-240V AC transformer (**T1**).

There are three secondary taps on the transformer. The first tap, connector **J3 pins 1 and 2**, is used with bridge rectifier **BR1** and capacitor **C9** to form a full-wave bridge rectifier. This rectifier supplies power to power amplifier **U401** and to +5V regulator circuit, **Q4**. **BR1** has a nominal output voltage of **14V**.

The second tap, **J3 pins 5 and 6**, provides a **3.3 Vac** signal which powers the filament of the Vacuum Fluorescent Display (VFD).

The third tap, **J3 pins 3 and 4**, supplies power to the rest of the radio. Diode **D5** and capacitor **C13** provide a half-wave rectifier, creating +20V (nominal), that feeds 10 volt regulator **U1**. **U1** powers most of the tuner and amplifiers. **U1** also regulates the 5 volt regulator **Q4**. The 5 volt supply is used by PLL IC **U601**, microprocessor (μ P) **U201**, display driver **U200**, and comparator **U202**.

The third tap is also used with capacitor **C11** and diode **D1** to create a negative voltage which is **-20 volts** (nominal). The -20 volts is used by **U200** to turn off segments in the display. Resistors **R211 and R212** provide a -10 volt bias for the VFD cathode. The -20 volts also powers the -8V supply through **Q1**, which supplies the amplifiers.

2. Control Electronics

The μ P (**U201**) controls the tuner, display, volume control and keyboard. The μ P runs at a nominal frequency of **4 MHz**, which is generated by ceramic resonator **X200** and internal circuitry in the μ P. The μ P is reset at **pin 1** by a rising edge caused by **U202 pin13**. This occurs automatically on power-up from a cold start. If the μ P is operating properly, then it provides a 100 ms square wave on **pin 30**. This resets watchdog timer **U202**. As long as the 100 ms pulse is present to reset the watchdog timer, **U202 pin 14** will stay high. If the μ P is not operating properly, it will stop generating the 100 ms pulse. The watchdog timer will then time out and pulse low for approximately 350ms. This will re-boot the μ P.

The μ P communicates with **U200** over a 4-wire serial data bus (**pins 15, 35, 36 and 38 of U201**). The bus is updated once per two milliseconds. **U201** latches the serial data into its outputs, driving the VFD. The VFD is a 5-grid multiplexed display with up to 14 anodes at each grid. The grids are turned on sequentially, 1 each millisecond. As each grid is turned on, the corresponding anodes for that grid area are turned on. This lights the desired segments. When the next grid is turned on, the anodes are changed to the desired segments under this next grid. In this way, the entire display is scanned, 1/5 at a time. The display is blanked during the period when one grid is turned off and the next grid is turned on.

There is another serial bus that controls PLL frequency synthesizer **U601** and volume control IC **U403**. The μ P sends clock and data information via **pins 19, 20, 21, 26 and 27** for these two ICs. The PLL and the volume control ICs have individual chip select lines: **PLL enable** and **Volume strobe**. Data is sent to the PLL when the tuner frequency is changed. The PLL enable line is high during this time. Data is sent to the Volume control IC when the volume is changed. When data is sent, the volume strobe is high.

THEORY OF OPERATION

Commands from the IR remote are received and detected by transistor **Q200** and are fed to **U201 pin 41**.

The μ P scans the keyboard looking for closures. **KS0, KS1, KS2, KS3 and KS4** are strobe outputs **pins 5, 8, 7, 1 and 2** respectively. **K0, K1, K2 and K3** are row inputs **pins 4, 6, 3 and 9** respectively.

Additionally, the μ P controls the following:

<u>Function</u>	<u>U201, pin#</u>
Source select (tuner or AUX)	thru PLL pin 9
Power amplifier mute	28
Display Intensity	38
Buzzer	29, 31

3. Battery Standby Circuitry

Q207 and **Q208** along with **D205** provide +5 volts to the "B" voltage line, when power is off, keeping the μ P on and the clock running. When AC power fails, **D209** provides a +6.2 volt signal to instantly mute the speakers to avoid pops and noise.

4. Display Dimming

Q201 and **Q202** modulate the cathode voltage with the DSP_BLANK signal giving a wide adjustment range. The intensity can be adjusted by depressing the clock button and adjusting the level with the volume up or down button. The intensity is preset to very dim. There are ten settings in the dim mode that can vary the intensity from approximately 2.5% to 25% of the bright level.

5. Audio Circuitry

The tuner audio and the external audio from the AUX input are routed to the source select IC **U402**. The μ P supplies a control voltage to **U402 pin 10**. A HI on **pin 10** selects tuner; a LO selects AUX.

The selected signal is fed to the Volume control IC **U403**, which consists of two sections. The first section attenuates the signal from 0 to 70 dB in 10 dB steps. The output of the first section is fed to the second half of **U403**. The second section attenuates the signal in 1 dB steps. The two sections provide attenuation from 0 to 80 dB in 1 dB steps.

U403's output is buffered by each half of op amp **U407** and is fed to the Variable Line Output jacks. Plugging a phono connector into the right Line output breaks the signal path and disables the internal speakers. This function can be disabled by attaching a 0 Ω chip at R505.

The audio is fed to the EQ circuitry. **U404, pin 1** and **U405, pins 1 and 7**, provide active filtering for the Twiddler™ channel. **U404, pins 7, 8 and 14** and **U405, pins 8 and 14**, provide active filtering for the full range channel. **U406** sums the bass from the left channel into the full range channel. **U406**, diodes **D400** and **D401**, capacitors **C411** and **C412** and transistors **Q403, 404** and **Q405** form a negative-peak detector. This detector generates a current that controls transconductance amp **U400** and provides the dynamic EQ.

THEORY OF OPERATION

Audio is fed to power amplifier IC **U401**. The power amp's output signal goes to the speakers.

The power amp provides an output when clipping starts at **pin 10**. This is fed to transistor **Q408**. When **Q408** turns on, **Q410** turns on providing bias to **U408 pin 5**. **U408** turns on and reduces the signal level at **U404** input **pin 9** thus reducing the full range channel volume. This is the compressor circuit. **Q407** is an inverter that puts the power amp chip in standby mode when the unit is "off".

6. Tuner

The FM signal is provided by the F connector (**J600**) and by the line cord, which is the antenna, via **C1**. Inductor **L4** is used to provide isolation between the FM RF input and the transformer. This signal is fed to the FM front end module, which contains a tuned RF amplifier, the FM local oscillator and the mixer. The mixer's output (**pin 7** of the module) is fed to ceramic filter **CF604**. Transistor **Q602** and related circuitry form a FM IF amplifier that produces about 15 dB of voltage gain and provides the proper impedance matching for ceramic filters **CF600** and **CF604**. **CF600's** output signal is fed to AM/ FM detector **U600**. This device contains the FM detector, FM stereo MPX decoder, stop-level detector and most of the AM circuitry. **U600** provides FM IF gain as well as FM detection using a single-tuned detector **T600**. **T600** is adjusted for minimum distortion.

The recovered FM composite signal is filtered by capacitor **C646** and then fed back into **U600 pin 22**. The value of **C646** affects FM stereo separation performance. The stereo MPX decoding is performed by **U600**, and the decoded Left and Right output signals are present on **U600, pins 16 and 17**. The MPX decoder uses the 456 kHz ceramic resonator **CF601** to set the oscillation frequency. The PLL loop filter components are connected to **U600 pin 14**. The FM stop level is adjusted by resistor **R617** on **U600 pin 30**.

Capacitors **C643** and **C647** perform FM de-emphasis. MPX filters, **L602** and **L603**, reject the residual 19kHz pilot before the audio signal reaches the source select IC, **U402**.

The AM signal is received by the ferrite bar antenna. The antenna is varactor tuned by diode **D600** and coupled by **L600** to **U600 pin 27**. A second tap on the antenna acts as the local oscillator coil. **U600** contains the AM-RF amplifier, Mixer, IF amplifier, AM detector and stop-level detector. The AM stop-level is set by resistor **R615**. The IF output signal that appears on **U600 pin 2** is filtered by **T601** and is fed back to **U600 pin 5**. It is demodulated by **U600** and sent to pins **16 and 17**, which are the left and right outputs.

The AM and FM local oscillators are controlled by PLL **U601**. The μ P selects the AM or FM band and the particular frequency. The 7.2 MHz crystal, **X600**, with internal PLL circuitry, provides a reference frequency that is divided down to 400 kHz and appears on **U601 pin 7**. **U601** divides down the local oscillator frequency and compares it to the reference frequency. An error signal is generated on **U601 pin 18**. This signal is integrated and filtered by transistors **Q604** and **Q603**, which produces the tuning voltage at the collector of **Q603**.

The AM tuning voltage is further filtered by resistor **R603** and capacitor **C604** and is fed to varactor diode **D600 pin 2**. This varies the capacitance of the varactor diodes, which in turn tunes the AM antenna and the AM-local oscillator. Similarly, for FM, resistor **R618** and capacitor **C629** produces filtering of the tuning voltage for the local oscillator and RF amp in the FM tuner module.

DISASSEMBLY/ASSEMBLY PROCEDURES

Note: Numbers in parentheses correspond to the item call outs in Figure 5.

1. Grille Removal

1.1 Place the unit upside down.

1.2 Insert a small flat-blade screwdriver into the four holes located on the bottom of the matrix (10) to disengage the grille (1) tabs.

1.3 Grasp the sides of the grille and pull it forward.

2. Grille Replacement

2.1 Place the unit upside down.

2.2 Lower the top side of the grille (1) onto the top of the matrix (10) so that the tabs on the grille line up with the slots located on the matrix.

2.3 Push the bottom of the grille into the bottom of the chassis until the tabs lock into place.

3. Switch Cover and PCB Removal

3.1 Perform procedure 1 first.

3.2 With the unit facing you, apply forward pressure on the rear of the switch cover (7), while holding the display PCB (11) in place. Lift the switch cover off.

3.3 The switch PCB (12) is heat staked to the switch cover. Cut the heat stakes leaving as much of the heat stake as possible. The PCB will lift off.

4. Switch Cover and PCB Replacement

4.1 Line up the switch PCB (12) in the switch cover (7) so that the connector J1 is located toward the Bose® logo.

4.2 Melt the heat stakes so that they secure the PCB to the switch cover.

4.3 Line up the switch cover with the matrix (10) so that the Bose logo is located toward the front of the unit.

4.4 Push the switch cover toward the rear of the unit until it snaps into place. Make sure connector J1 is securely seated.

5. Display PCB Removal

5.1 Perform procedure 1, and 3.2 first.

5.2 Pull the top of the display PCB (11) forward. Move the speaker harness (5) out of the way as needed.

5.3 Disconnect the ribbon cable (6) from the connector J201. Lift the PCB out of the unit.

6. Display PCB Replacement

6.1 Connect the ribbon cable (6) to the connector J201. Lower the display PCB (11) into the front of the unit so that the bottom of the Display PCB fits into the slots on the matrix (10). The speaker wire harness (5) should be in front of the display PCB.

6.2 Push the display PCB into the matrix making sure the tabs on the Matrix line up with the slots on the display PCB.

7. Driver Removal

7.1 Perform procedure 1 first.

7.2 Remove the four screws (13) that secure the driver (3) and/ or (4) to the matrix (10) and lift the driver out.

7.3 Remove the wire connectors from the driver terminals.

DISASSEMBLY/ASSEMBLY PROCEDURES

8. Driver Replacement

8.1 Connect the wire connectors to the driver (3) and/ or (4) terminals.

8.2 Replace the four screws (13) that secure the driver to the matrix (10).

9. Pedestal Removal

9.1 With the unit upside down and the front facing you, remove the four screws (14) that secure the pedestal (9) to the matrix (10).

9.2 Tilt the pedestal up and toward the front of the unit. Disconnect the speaker harness (5) and the display PCB ribbon cable (6) from the main PCB (11). Lift the pedestal up and out of the matrix.

10. Pedestal Replacement

10.1 Connect the display PCB ribbon cable (6) and the speaker harness (5) to the main PCB (11).

10.2 Lower the pedestal (9) into the matrix (10). Replace the four screws (14) that secure the pedestal to the matrix.

11. Transformer Removal

11.1 Perform procedure 9 first.

11.2 Remove the four screws (14) that secure the transformer (2) to the pedestal (9).

11.3 Disconnect the connectors from J2 and J3. Lift the transformer up.

12. Transformer Replacement

12.1 Lower the transformer (2) into the pedestal (9) so that the wire connector for J2 is facing toward the AC jack.

12.2 Replace the four screws (14) that secure the transformer to the pedestal.

12.3 Connect the wire connectors to J2 and J3. Dress the secondary wire (J3) so that the speaker wire runs under it.

13. Main PCB Removal

13.1 Perform procedure 9 and 11.2 first.

13.2 Remove the battery connector from the 9V battery.

13.3 Lift the transformer (2) and the main PCB (11) up.

14. Main PCB Replacement

14.1 Lower the transformer (2) and the main PCB (11) into the pedestal (9) so that the FM connector lines up with the slot in the rear of the pedestal.

14.2 Dress the 9 Volt battery connector wires in the channel located by the battery compartment.

14.3 Replace the four screws (14) that secure the transformer to the pedestal.

TEST PROCEDURES

General Test Setup

Twiddler® channel output : J400 pins 1, 2
Full Range channel output : J400 pins 3, 4

Output loading: Twiddler-8Ω, 1%, 10W
Full Range-4Ω, 1%, 25W

Adjust the volume to 99 unless otherwise noted.

All test equipment connected to J400 must be floated (isolated from ground). The signal source ground must be isolated from the equipment connected to the connector J400.

1. Channel Separation

1.1 Apply a 1Vrms, 1.2kHz signal to the left AUX input. Ground the right AUX input. Adjust the volume to 65.

1.2 Reference a dB meter to J400 pins 3 (+) and 4 (-).

1.3 The Twiddler output measured at J400 pins 1(-) and 2 (+) should be ≤ 55 dB.

3. Compressor Distortion Test

3.1 Apply a 330mVrms, 150Hz signal to the left and right AUX input.

3.2 Adjust the volume to 99.

3.3 Measure the output at J400 pins 3 (+) and 4 (-). The output should measure $< 5.0\%$ THD.

4. Output Noise

4.1 Put the unit in the AUX mode and short the AUX inputs.

4.2 The output noise measured at J400 pins 1 (-) and 2 (+) should be < 0.3 mV, A-Weighted. J400 pins 3 (+) and 4 (-) should be < 1.2 mV, A-Weighted.

5. Full Range Channel Reference Gain

5.1 Apply a 15mVrms, 1.2kHz signal to the left and right AUX input.

5.2 Reference a dB meter to the applied signal.

5.3 The output measured at J400 pins 3 (+) and 4 (-) should be $+31.9 \pm 2$ dB.

6. Full Range Channel Relative Frequency Response.

6.1 Apply a 15mVrms, 1.2kHz signal to the left and right auxiliary input.

6.2 Reference a dB meter to the output at J400 pins 3 (+) and 4 (-).

6.3 Measure the frequency response at J400 pins 3 (+) and 4 (-) according to the following table.

Frequency	Output
60Hz	$+8.5$ dB ± 2.5 dB
80Hz	$+17.0$ dB ± 2.0 dB
300Hz	-2.2 dB ± 1.0 dB
480Hz	-6.0 dB ± 1.5 dB
1.2kHz	Reference
1.8kHz	-1.2 dB ± 1.0 dB
5.1kHz	$+10.0$ dB ± 1.5 dB
10kHz	$+19.8$ dB ± 1.5 dB
20kHz	$+20.4$ dB ± 2.0 dB

7. Full Range Dynamic Equalizer

7.1 Apply a 15mVrms, 1.2kHz signal to the left and right AUX input.

7.2 Reference a dB meter to J400 pins 3 (+) and 4 (-).

7.3 Apply a 2mVrms, 80Hz signal to the left and right AUX input.

7.4 The output measured at J400 pins 3 (+) and 4 (-) should be $+4.6 \pm 1.0$ dB.

TEST PROCEDURES

8. Full Range Small Signal Distortion at 0.1W

8.1 Apply a 32mVrms, 1kHz signal to the left and right AUX input.

8.2 The distortion measured at J400 pins 3 (+) and 4 (-) should be < 0.5% THD.

9. Full Range Large Signal Distortion at 6W

9.1 Apply a 120mVrms, 1kHz signal to the left and right AUX input.

9.2 The distortion measured at J400 pins 3 (+) and 4 (-) should be < 0.2% THD.

9. Twiddler® Reference Gain

9.1 Apply a 30mVrms, 800Hz signal to the right AUX input.

9.2 Reference a dB meter to the applied signal.

9.3 The output measured at J400 pins 1 (-) and 2 (+) should be +27.9dB ± 2.0dB.

10. Twiddler Relative Frequency Response

10.1 Apply a 30mVrms, 800Hz signal to the right AUX input.

10.2 Reference a dB meter to J400 pins 1 (-) and 2 (+).

10.3 Measure the frequency response at J400 pins 1 (-) and 2 (+) according to the following table.

Frequency	Output
200Hz	-10.5dB ± 1.5dB
500Hz	-0.6dB ± 1.0dB
800Hz	Reference
2.3kHz	-5.0 db ± 1.0dB
6.0kHz	+2.6dB ± 1.0dB
12.0kHz	+8.1dB ± 1.0dB
20kHz	+1.4dB ± 2.0dB

11. Right Channel Small Signal Distortion at 0.5W

11.1 Apply a 50mVrms, 1kHz signal to the right AUX input.

11.2 The distortion measured at J400 pins 1 (-) and 2 (+) should be < 0.1% THD.

12. Right Channel Large Signal Distortion

12.1 Apply a 180mVrms, 1.0kHz signal to the right AUX input.

12.2 The distortion measured at J400 pins 1 (-) and 2 (+) should be < 0.2% THD.

AM ALIGNMENT

General Test Setup

Unless otherwise noted, Set an RF generator to 1500kHz, 74dB (EMF), 30% AM modulation, 400Hz modulation. Measurements are taken from the AUX output. Refer to Figure 4.

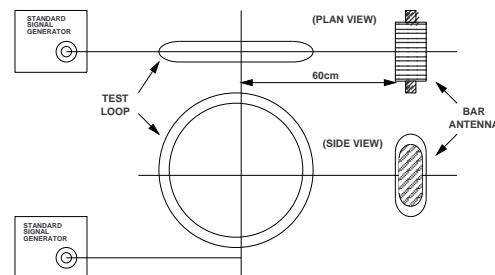

The equivalent field intensity is 26dB less than the generator output level or 1/20th of the output voltage.

Figure 4. AM Test Setup

Note: AM stop level adjustment must be performed before FM stop level adjustment because it affects the FM stop performance.

13. AM Tuner Adjustment

13.1 Adjust trim cap C609 (trim cap) for peak audio level.

TEST PROCEDURES

13.2 Set the RF generator and the unit to 600kHz then adjust L600 for peak audio level.

13.3 Set the RF generator and the unit to 1500kHz then adjust C609 (trim cap) for peak audio level.

14. AM Sensitivity

14.1 Set the RF generator and the unit to 1080kHz, 79 dB (EMF).

14.2 Connect a 100Hz or 200Hz high-pass filter and reference a DB meter to the AUX output.

14.3 Switch the 400Hz modulation off. The AUX output should be < 20dB, SNR.

15. AM Stop Level Adjustment

15.1 Set the RF generator to 76dB (EMF) at 1080kHz.

15.2 Rotate R615 counterclockwise until the voltage at U600 pin 7 goes below 2.8VDC and then clockwise until it goes above 2.8VDC.

Note: The correct adjustment is at the point just after the voltage switches high.

15.3 Switch the RF generator to 79dB (EMF) and verify that U600 pin 7 is less than 2.8VDC.

15.4 Set the RF generator to 82 dB (EMF) at 1170kHz. Put the unit into the seek mode. Verify that it stops at 1170kHz.

Note: If the unit passes the stop level adjustment but fails the SEEK stop, verify that the FM stop potentiometer, R617, is not fully counterclockwise. If it is, then rotate R617 at least 30° clockwise.

FM ALIGNMENT

Note: The FM stop level adjustment must be performed after the AM stop level adjustment because the AM adjustment affects the FM performance.

General Test Setup

Unless otherwise noted, Set the RF generator to 98.1MHz, 64dB (EMF), mono modulation, 75kHz deviation, 1kHz modulation. Inject the FM signal into the FM connector (J600) using a 50Ω to 75Ω resistive matching network (5.7dB insertion loss). Adjust the unit to 98.1MHz.

16. FM Detector Adjustment

16.1 Adjust T600 for minimum distortion. Adjust the AUX audio output level to > 360mVrms. The distortion should be < 0.6%.

16.2 Verify that there is 560mVrms ± 200mVrms audio at the left output.

17. Stereo Separation

17.1 Set the RF generator for 100% FM stereo modulation, left mode, 10% pilot.

17.2 Reference a dB meter to the right AUX output.

17.3 Switch the FM stereo modulator to the right mode. The stereo separation should be > 20dB.

18. FM Stop Level

18.1 Set the RF generator to 36dB (EMF), 98.1MHz.

18.2 Rotate R617 counterclockwise until the voltage at U600 pin 7 goes below 2.8VDC and then clockwise until it goes above 2.8VDC.

TEST PROCEDURES

Note: The correct adjustment is at the point just after the voltage switches high.

18.3 Adjust the RF generator to 39dB (EMF) and verify that the voltage at U600 pin 7 is low.

18.4 Set the RF generator to 42dB (EMF), 100.1MHz. Put the unit into the seek mode. The unit should stop at 100.1MHz.

19. FM Sensitivity

19.1 Set the RF generator to 46dB (EMF), stereo mode.

19.2 Reference a dB meter to left or right AUX output.

19.3 Turn off the 1kHz modulation. The SNR should be > 50dB.

PART LIST NOTES

1. This part is not normally available from customer service. Approval from the Field Service Manager is required before ordering.
2. The individual parts located on the PCB are listed in the part list.
3.  This part is critical for safety purposes. Failure to use a substitute replacement with the same safety characteristics as the recommended replacement part might create shock, fire and/or other hazards.
4. This PCB is part of a pallet. The pallet contains the Display PCB and the Main PCB. These two PCBs are manufactured and sold as a pallet.

MAIN ASSEMBLY PART LIST

Item Number	Description	Part Number	Note
1	GRILLE ASSY, WHT GRILLE ASSY, GRY	188490-001 188490-002	
2	TRANSFORMER, POWER, 120V TRANSFORMER, POWER, 100V TRANSFORMER, POWER, 220V-240V	187595-001 188465-001 188461	3 ⚠
3	FULL RANGE, 57mm (LEFT)	193430-001	📄
4	TWIDDLER, 57mm (RIGHT) TWIDDLER, 57mm (RIGHT), SHIELDED	171494 148704-001	JAP
5	CABLE, TWIDDLER	172584 or 196439	📄
6	CABLE, RIBBON, 21 CONDUCTOR	177256	
7	COVER ASSY, SWITCH, WHT COVER ASSY, SWITCH, GRY	180518-001 180518-002	
8	PAD, SW, ELASTOMERIC, WHITE PAD, SW, ELASTOMERIC, GRY	185180-001 185180-002	
9	PEDESTAL, BLACK	258796-001	
10	MATRIX ASSY, WH MATRIX ASSY, GRY	188453-001 188453-002	1
11	PCB ASSY, BWR III, 120V PCB ASSY, BWR III, 220V PCB ASSY, BWR III, 100V	187615-001 187615-002 187615-003	1, 2, 4
12	PCB ASSY, BWR, SWITCH	147212	
13	SCREW, HILO, 6x.5, PAN, XREC	175972-08	
14	SCREW, TAPP, 8-11x.625, PAN, XRC/S	172672-10	
15	PAD, FOAM ADHESIVE BACK	178945	
16	BATTERY, DOOR	187627-001	1
17	SHIELD, BOTTOM	171902	JAP/VIDEO
18	SHIELD, WOOFER, TOP	171903	JAP/VIDEO
-	FOOT, RUBBER	188462-001	
-	FOAM, BATTERY COMPARTMENT	188458-001	

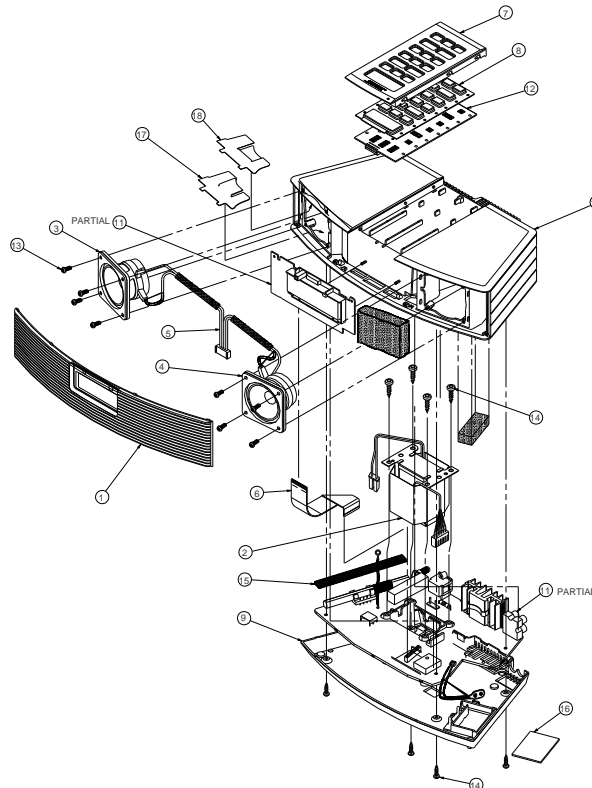



Figure 5. Exploded View

ELECTRICAL PART LIST

Resistors

Reference Designator	Description	Part Number	Note
R1	CF, 1/2W, 5%, 52mm, 10M	121243-1511065	 3 100/115V
R2, 422, 423, 443	3.32K, 0805, 1/10W, 1%	133625-3321	
R4, 278, 459	4.87K, 0805, 1/10W, 1%	133625-4871	
R5	270Ω, 1210, 1/4W, 5%	187607-2715	
R6	1 Ω, FUSING, 1/2W, 5%	188460-1R0	 3
R7, 9, 230, 234, 235, 236, 238, 243, 248, 249, 251, 253, 254, 255, 273, †274, ¥275, 279, 283, 400, 452, 465, 468, 478, 487, 488, 619, 630	10.0K, 0805, 1/10W, 5%	133626-1035	‡ EURO ¥ US/ JAPAN
R8, 200, 201, 202, 203, 205, 265, 266, †271, ¥272, 281, 403, 484, 490, 601, 618, 623, 626	1.00K, 0805, 1/10W, 5%	133626-1025	‡ JAPAN ¥ US/ EURO
R10, 604	2.32K, 0805, 1/10W, 1%	133625-2321	
R12	51Ω, 1210, 1/4W, 5%	187607-5105	
R13, 474, 475, 610	3.01K, 0805, 1/10W, 1%	133625-3011	
R15	78.7K, 0805, 1/10W, 1%	133625-7872	
R16	270Ω, 1W, 5%, 2512	181895-2700	
R204	390K, CHIP, 0805, 1/10W, 5%	133626-3945	
R206, 470	30K, CHIP, 0805, 1/10W, 5%	133626-3035	
R209	820Ω, 1210, 1/4W, 5%	187607-8215	
R211, 237, 241, 406, 415, 451, 611	20Ω, 0805, 1/10W, 5%	133626-2005	
R212	1K, 2010, 1/2W, 5%	187608-1025	
R213, 214, 407, 421, 489, 492, 501, 502, 503, 504, 602, 629	100Ω, CHIP, 0805, 1/10W, 5%	133626-1015	
R215, 217, 223, 224, 225, 226	68.0K, 0805, 1/10W, 5%	133626-6835	
R216, 620	4.75K, 0805, 1/10W, 1%	133625-4751	
R218, 219, 220, 221, 222, 263, 264	220K, 0805, 1/10W, 5%	133626-2245	

ELECTRICAL PART LIST

Resistors (continued)

Reference Designator	Description	Part Number	Note
R227, 228, 244, 245, 247, 260, 261, 268, 277, 285, 480, 493, 495	100K, 0805, 1/10W, 5%	133626-1045	
R229, 242, 269, 270, 282, 425, 428, 672	1M, 0805, 1/10W, 5%	133626-1055	
R231, 232, 233, 239, 240	6.80K, 0805, 1/10W, 5%	133626-6825	
R250	15K, CHIP, 0805, 1/10W, 5%	133626-1535	
R262, 276	150K, 0805, 1/10W, 5%	133626-1545	
R280	5.10K, 0805, 1/10W, 5%	133626-5125	
R286	120 Ω , 0805, 1/10W, 5%	133626-1215	
R287	19.6k, CHIP, 0805, 1/10W, 5%	133625-1962	
R288, 496, 498, 603, 606	3.90K, 0805, 1/10W, 5%	133626-3925	
R289	180K, CHIP, 0805, 1/10W, 5%	133626-1845	
R401, 402	21.0K, 0805, 1/10W, 1%	133625-2102	
R404, 411	6.19K, 0805, 1/10W, 1%	133625-6191	
R405, 608	2.49K, 0805, 1/10W, 1%	133625-2491	
R408	196 Ω 0805, 1/10W, 1%	133625-1960	
R409	332 Ω , CHIP, 0805, 1%	133625-3320	
R412	332 Ω , CHIP, 0805, 1%	133625-3320	
R414	88.7K, 0805, 1/10W, 1%	133625-8872	
R416, 418, 444	22.1K, 0805, 1/10W, 1%	133625-2212	
R417, 456, 485	15.4K, 0805, 1/10W, 1%	133625-1542	
R419, 437, 466	750 Ω , 0805, 1/10W, 1%	133625-7500	
R420	26.7K, 0805, 1/10W, 1%	133625-2672	
R424	21.5K, 0805, 1/10W, 1%	133625-2152	
R430, 432, 460	1.21K, 0805, 1/10W, 1%	133625-1211	
R431, 446	100 Ω , 0805, 1/10W, 1%	133625-1000	
R433, 628	3.48K, 0805, 1/10W, 1%	133625-3481	

ELECTRICAL PART LIST

Resistors (continued)

Reference Designator	Description	Part Number	Note
R434, 439, 453, 616, 625	10K, 0805, 1/10W, 1%	133626-1035	
R435	732Ω, 0805, 1/10W, 1%	133625-7320	
R436, 455, 463	4.22K, 0805, 1/10W, 1%	133625-4221	
R438	12.1K, 0805, 1/10W, 1%	133625-1212	
R440	590Ω, 0805, 1/10W, 1%	133625-5900	
R441	34.8K, 0805, 1/10W, 1%	133625-3482	
R442	42.2K, 0805, 1/10W, 1%	133625-4222	
R445	23.2K, 0805, 1/10W, 1%	133625-2322	
R447	1.02K, 0805, 1/10W, 1%	133625-1021	
R448	267Ω, 0805, 1/10W, 1%	133625-2670	
R450, 600	49.9Ω, 0805, 1/10W, 1%	133625-49R9	
R454	1.78K, 0805, 1/10W, 1%	133625-1781	
R458	13.3K, 0805, 1/10W, 1%	133625-1332	
R464	23.7K, 0805, 1/10W, 1%	133625-2372	
R467	110K, 0805, 1/10W, 1%	133625-1103	
R471	36.5K, 0805, 1/10W, 1%	133625-3652	
R473	4.64K, 0805, 1/10W, 1%	133625-4641	
R476	4.99K, 0805, 1/10W, 1%	133625-4991	
R479	4.02K, 0805, 1/10W, 1%	133625-4021	
R497	7.50K, 0805, 1/10W, 1%	133625-7501	
R499	7.50K, 0805, 1/10W, 1%	133625-7501	
R605	499Ω, CHIP, 0805, 1/10W, 1%	133625-4990	
R609	330Ω, 0805, 1/10W, 5%	133626-3315	
R615	POT, RTRY, 20K, 30%, 1/2W, TRIM	177494-203	
R617	POT, RTRY, 5K, 30%, 1/2W, TRI	177494-502	
R621	1.60K, 0805, 1/10W, 5%	133626-1625	

ELECTRICAL PART LIST

Resistors (continued)

Reference Designator	Description	Part Number	Note
R622	620Ω, 0805, 1/10W, 5%	133626-6215	
R624, 483, 486, 491, 607, 627	4.7K, CHIP, 0805, 5%	133626-4725	
R632	30.1Ω, 0805, 1/10W, 1%	133625-30R1	
R635, 637	4.3K, CHIP, 0805, 1/10W, 5%	133626-4325	
R634, 636	3.3K, CHIP, 0805, 5%	133626-3325	

Capacitors

Reference Designator	Description	Part Number	Note
C1	33pF, CER, 85, 400VAC, 20%	183627-330	 3 100/ 115V
C2, 5, 6, 7, 8, 12, 13, 205, 247, 441, 444, 601, 606, 611, 619, 620, 633, 637, 639, 642, 643 , 644, 647	.047uF, 0805, X7R, 50V, 10%	133623-473	US See supplement 191514-S1
C9	10000uF, EL, 105, 25V, 20%	171555	
C11, 16	470uF, EL, 85, 35V, 20%	149948-471V	
C14, 19, 437, 438, 607	.47uF, EL, 85, 50V, 20%	149947-R47H	
C15, 246, 451, 600, 618, 640	47uF, EL, 105, 16V, 20%	137126-470	part change to increase operating temp. BT
C17, 227, 228, 229, 230, 231, 250, 252, 253, 254, 401, 404, 410, 413, 414, 436, 442, 445, 455, 456, 460, 461, 602, 646, 654, 655, 656	1000pF, 0805, X7R, 50V, 10%	133623-102	See supplement 191514-S4
C18, 439, 638	100uF, EL, 85, 16V, 20%	149947-101C	
C200, 202	220uF, EL, 85, 6.3V, 20%	149947-221J	
C206	4700pF, 0805, X7R, 50V, 10%	133623-472	
C209, 235, 238, 240, 241, 242, 243, 245, 251, 632, 635, 648, 649	100pF, 0805, COG, 50V, 5%	133622-101	
C224, 225, 403, 416, 417	.1uF, BOX, 85, 50V, 5%	137127-104	
C232	470pF, 0805, COG, 50V, 5%	133622-471	
C233, 249, 622	3.3uF, EL, 85, 50V, 20%	149947-3R3H	

ELECTRICAL PART LIST

Capacitors (continued)

Reference Designator	Description	Part Number	Note
C234	MONO, 1206, Y5V, 16V, 80%, 2.2uF	178212-225	
C236, 237	39pF, 0805, COG, 50V, 5%	133622-390	
C239, 407, 448, 457, 458, 605, 630, 634	.01uF, 0805, X7R, 50V, 10%	133623-103	
C244, 629	.33uF, EL, 85, 50V, 20%	149947-R33H	
C248	1206, X7R, 25V, 5%, .1uF	131754-104	
C400	.027uF, BOX, 85, 63V, 5%	137127-273	
C402	.056uF, BOX, 85, 63V, 5%	137127-563	
C405, 406	.12uF, BOX, 85, 50V, 5%	137127-124	
C408, 411, 412, 443, 449, 450, 612, 621, 623, 624, 626, 650, 652	10uF, EL, 85, 25V, 20%	149947-100E	
C409, 432, 433	.47uF, BOX, 85, 50V, 5%	137127-474	
C418, 420, 643, 647	.033uF, BOX, 85, 63V, 5%	137127-333	EUR/ JAPAN
C419, 421, 424, 425	.012uF, BOX, 85, 100V, 5%	137127-123	
C422	.0068uF, BOX, 85, 100V, 5%	137127-682	
C423, 426	.27uF, BOX, 85, 50V, 5%	137127-274	
C427, 428	.022uF, BOX, 85, 100V, 5%	137127-223	
C429, 430	.039uF, BOX, 85, 63V, 5%	137127-393	
C431	.0047uF, BOX, 85, 100V, 5%	137127-472	
C434	330pF, 0805, COG, 50V, 5%	133622-331	
C459	4.7uF, EL, 85, 50V, 20%	149947-4R7H	
C603	3.9pF, 0805, COG, 50V, 5%	133622-3R9	
C604	1206, X7R, 25V, 5%, .1uF	131754-104	
C609	20pF, TRIM, NPO, 100V	148768-T200	
C610	430pF, 0805, COG, 50V, 2%	177269-431	
C614, 615, 617	1.0uF, EL, 85, 50V, 20%	149947-1R0H	
C616	4.7uF, EL, 85, 50V, 20%	149947-4R7H	
C625	.022uF, 0805, X7R, 50V, 10%	133623-223	

ELECTRICAL PART LIST

Capacitors (continued)

Reference Designator	Description	Part Number	Note
C631	2.2uF, EL, BP, 85, 50V, 20%	147522-2R2	
C636, 641	33pF, 0805, COG, 50V, 5%	133622-330	
C645	1.0uF, EL, BP, 85, 50V, 20%	147522-1R0	
C651, 653	1800PF, 0805, COG, 50V, 5%	133622-182	

Diodes

Reference Designator	Description	Part Number	Note
D1, 5	SMT, S1G	178380-4	
D2, 201, 202, 203, 209	1N4531, 5MM	136603	
D200	SENSOR, LIGHT, VISIBLE	187629-001	
D205	ZEN, 6.2V, .5W, 5%, SOD-123	174265-5234	
D206, 207, 208, 400, 403, 404, 601, 602, 603	DUAL, SOT-23, BAV99	147239	
D3, 401	DUAL, SOT-23, BAV70	147249	
D600	VARACTOR, DUAL, 20V, 50mA	177495-5	
BR1	RECTIFIER, BRIDGE, KBJ601G	187611-001	 3

Transistors

Reference Designator	Description	Part Number	Note
Q3, 201, 206, 207, 403, 410	BPLR, N, 55V, 150mA, SOT23	134741	
Q4	BPLR, N, 80V, 700mA, TO-92	140348	
Q200	SENSOR, IR DETECTING	187205	
Q202, 404, 405	BPLR, P, 55V, 150mA, SOT23	258007	Alt. 134743
Q204, 407, 605, 606	SOT23, BPLR, N, 50V, 100mA	146817	
Q208	PNP, SOT, 2SA1252	187605-001	
Q408, 409, 607	BPLR, P, 50V, 100mA, SOT23	146818	
Q602	BPLR, N, 25V, 30MA, SOT-23	187601-001	

2/02

ELECTRICAL PART LIST

Transistors (continued)

Reference Designator	Description	Part Number	Note
Q603	BT3904, NPN, SOT, MM	146819	
Q604	JFET, N, 40V, 10mA, TO-92	147561-3	

Integrated Circuits

Reference Designator	Description	Part Number	Note
U1	LM78M10, TO-220	178352-10	
U200	VFD DRIVER, DIP- 28, MM58342	146813	
U201	IC, uC, 44 POS, J- LEAD, BWR, MASKED	177401	
U202	VOLTAGE COMPARATOR, LM339	187618-001	
U400, 408	OP AMP, SNGL, SO-8, CA3080	187617-001	
U401	POWER AMP MW15, TDA7375A	250117	
U402	MULTIPLEXER, HCF4052BEY	187620-001	
U403	VOLUME CNTRL, DIP-16, TC9213P	147622	
U404, 405	QUAD OP AMP, TLO74D, SOIC	186112	
U406	OP AMP, DUAL, SO-8, NJM4556	148598	
U407	OP AMP, DUAL, TL072	187619-001	
U600	AM/FM, TUNER, SO-20 LA1836	187600-001	
U601	PLL FREQ SYNTH, DIP-20	147527	

Inductors





Reference Designator	Description	Part Number	Note
L2	10uH, IND, SMT, LEM4532	178370-100	
L3, 4	2.2uH, COM MODE	187598-2R2	 3
L600	COIL, OSCILLATOR	180647	
L601	100uH, SMT, LEM4532	178370-101	
L602	FILTER, STEREO MPX, SINGLE TUNED	187624-001	

ELECTRICAL PART LIST

Inductors

Reference Designator	Description	Part Number	Note
L603	FILTER, STEREO MPX, SINGLE TUNED	187624-001	

Miscellaneous

Reference Designator	Description	Part Number	Note
F1	250V, SLBLO 0.75A 0.5A	135677-04 135677-03	 3 100V/ 115V 220V/ 240V
DISPLAY	DISPLAY, VACUUM FLUORESCENT	147226	
TUNER	TUNER, FM,3 GANG, 7V, US TUNER, FM 76- 90MHZ, 7V, JAPAN	180995 188466-001	US JAPAN
T600	DETECTOR, FM, SINGLE TUNED	187602-001	
T601	FILTER, CER, AM IF	187603-001	
X200	RESONATOR,CER , 4MHz	147534	
X600	CRYSTAL, QUARTZ, 7.2MHz, 50PPM	147223	
CF600	FILTER,CER,10.7 MHZ,180+-20KHZ	179028	
CF601	RESONATOR,CER AMIC, 456KHz	187604-001	
CF604	FILTER, CER, 10.7 MHZ, 180+-20KHZ	179028	
BUZZ1	SOUNDER, PIEZOELECTR	149562	
AM-ANT	ANTENNA, FERRITE BAR	177268	
J1	CONN, AC	146563 145306	 3 100V/ 115V 220V-240V
J2	CONN, HEADER, 2 POS, 8MM	178742-2	 3
J3	CONN, HEADER, INLINE, PCB MNT, 6P	133220-06	 3
J4	CONN, HEADER, TOP ENTRY, 21 POS	177257-21	
J5	CABLE, BATTERY/ADAPTE R, 9 VOLT	187610-001	
J200	CONN, HEADER, SHIELDED, 10 POS	147246-10	

ELECTRICAL PART LIST

Miscellaneous (continued)

Reference Designator	Description	Part Number	Note
J201	CONN, HEADER, SIDE ENTRY, 21 POS	177258-21	
J400	CONN, HEADER, INLINE, PCB MNT, 4P	133220-04	
J401	CONN, HOUSING, PHONO, QUAD, 8 POS	147227	
J600	CONN, FM ANTENNA	178354 179271	US/ JAPAN EURO
FOR/ MICRO	SHIELD, IC, BWR	188468-001	
	SHIELD, IC	178944	
	SCREW, TAPP, M3.5x0.6x10, PAN, TRX	140447-10	
	CLIP, SPRING	142864	
	HOLDER, DISPLAY	175357	
	HEATSINK	177562	

PACKAGING PART LIST

Item Number	Description	Part Number	Note
1	BWR REMOTE, WHT BWR REMOTE, GRY	189752-003 189752-002	
2	BATTERY, LITHIUM, CR2032 OR DL2032	180991	⚠ 3
3	BATTERY, CARBON, 9 VOLT	187609-001	
4	LINE CORD, DETACHABLE	172045 148203 134725 134726	⚠ 3 US EUR UK, SINGAPO AUS JAPAN
5	CARTON, RSC, BWR	183793	
6	PACKING, ENDCAP	183481	
7	BAG, POLY, 17.5x17.1x4 mil, SHIP	149205	
8	MANUAL, OWNER'S, BWR III	198321	
9	BAG, POLY, 4 x 12 x 3 mil	144348	
10	SHEET, QUICKSTART, BWR III	189617	
-	SHEET, SAFETY	176236	
-	ALL PRODUCTS BROCHURE	188898	
-	CARD, WARRANTY, MULTI LANG	180925	
-	VELCRO, HOOK AND LOOP, MATED	188463-001	

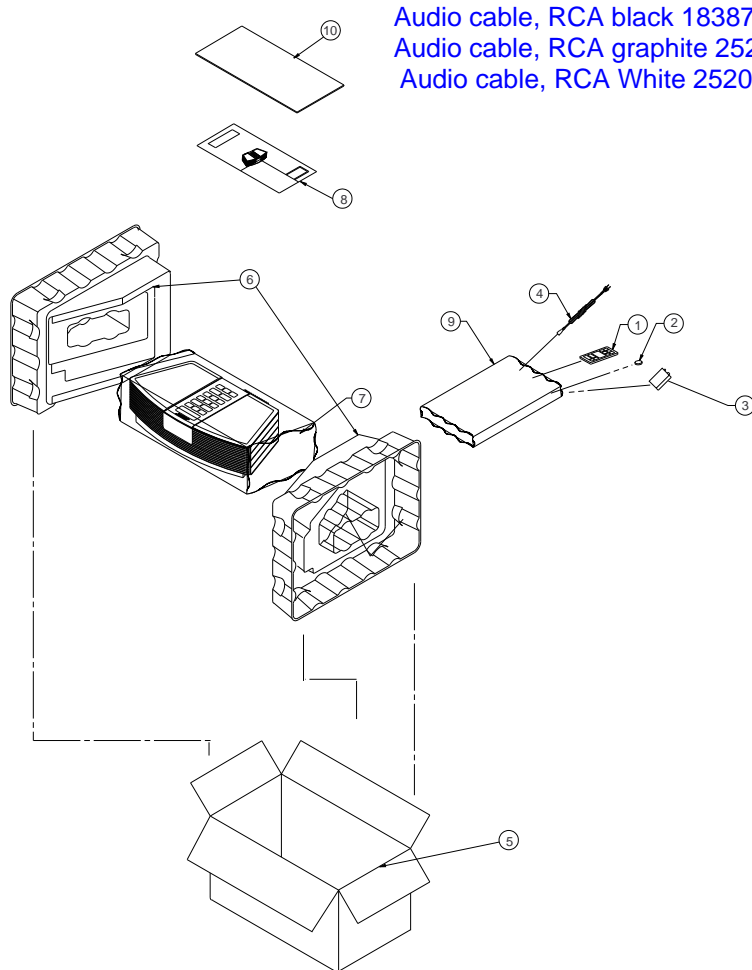
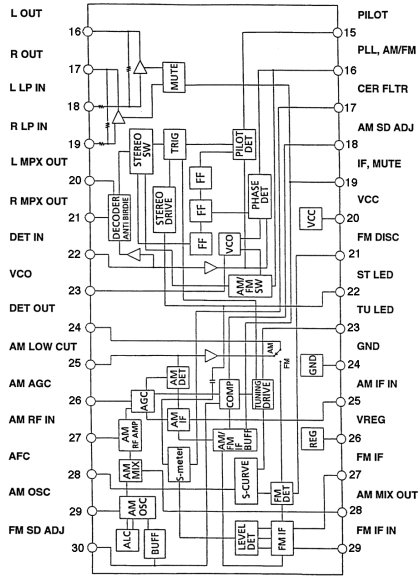
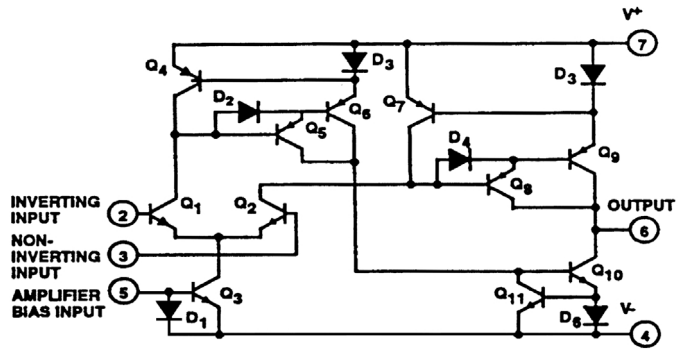

Figure 6. Packaging View

INTEGRATED CIRCUIT DIAGRAMS



**U600
LA1836**



**U400, 408
CA3080**

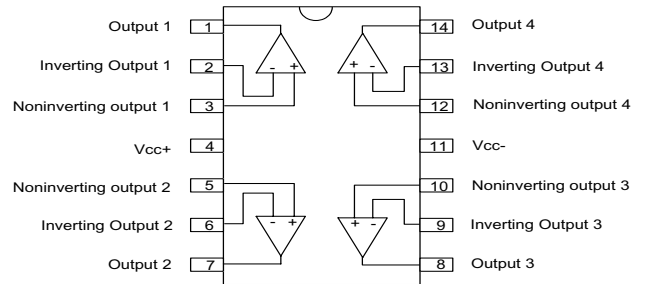

**U404, 405
TL074**

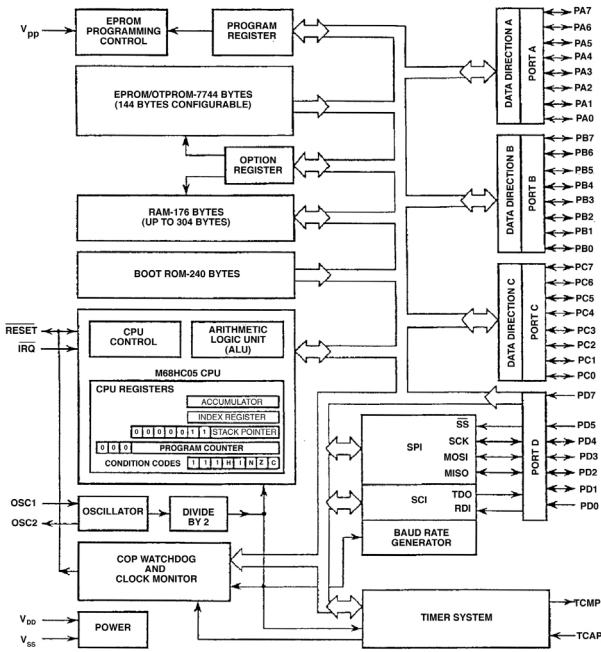

**U201
Microcontroller
MC68HC705C8**

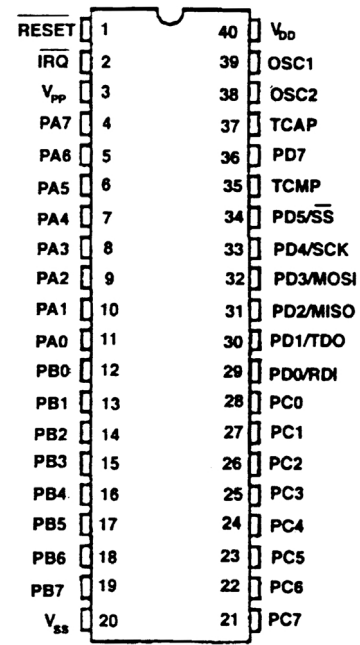

**U201
Microcontroller
MC68HC705C8**

INTEGRATED CIRCUIT DIAGRAMS

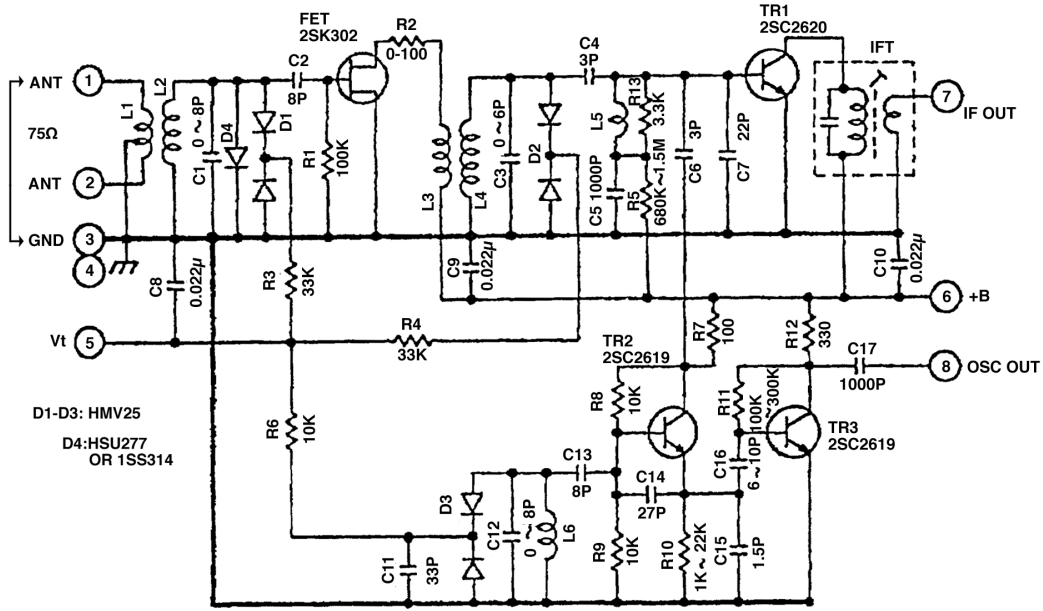

Tuner
FM Front End Module, 7V

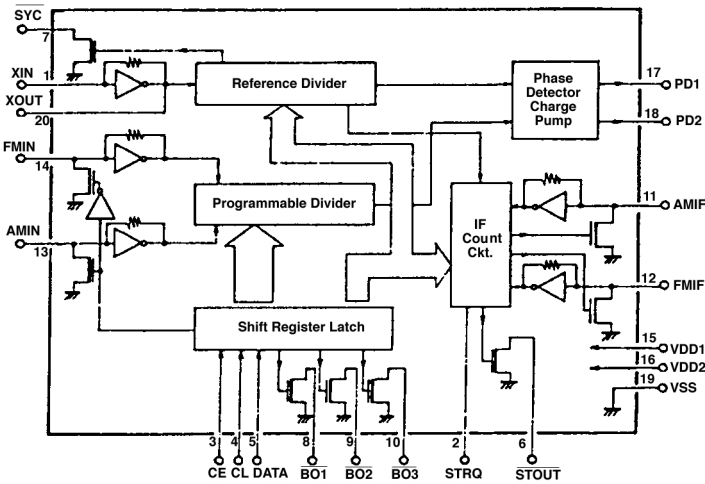

U601
PLL Frequency
Synthesizer

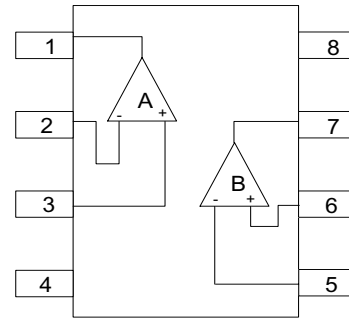

U406
4556

INTEGRATED CIRCUIT DIAGRAMS

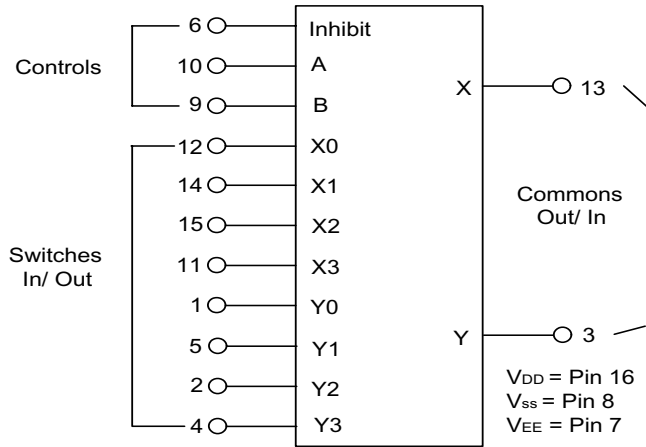

U402
CD4052

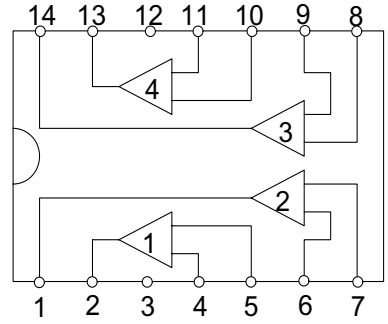

U202
LM339

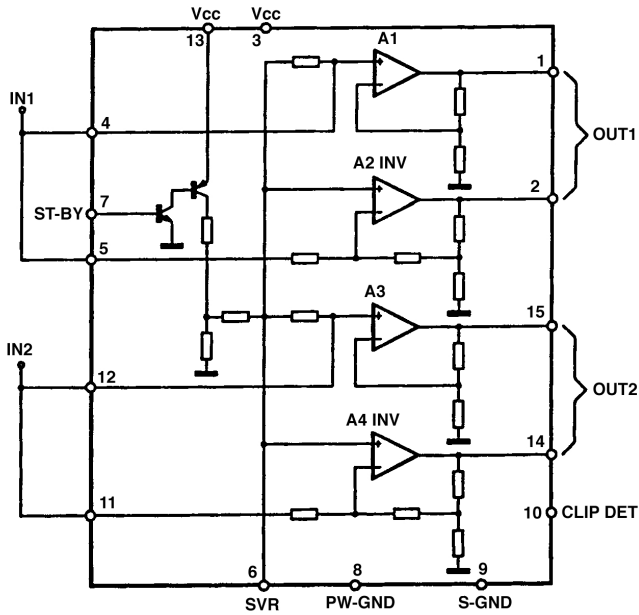

U401
Power Amplifier-Dual Bridge
TDA 7375

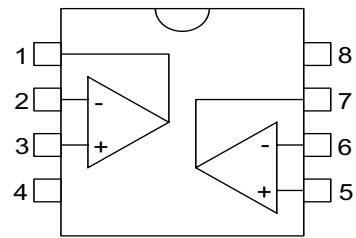

U407
TL072

INTEGRATED CIRCUIT DIAGRAMS

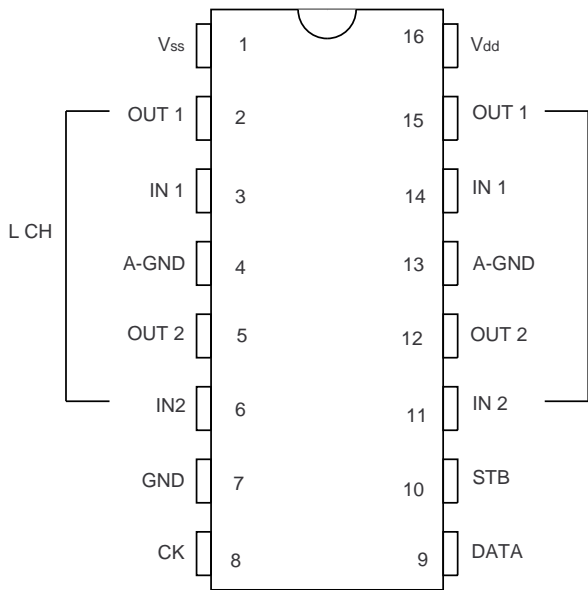

U403
Volume control Pin Out
TC9213P

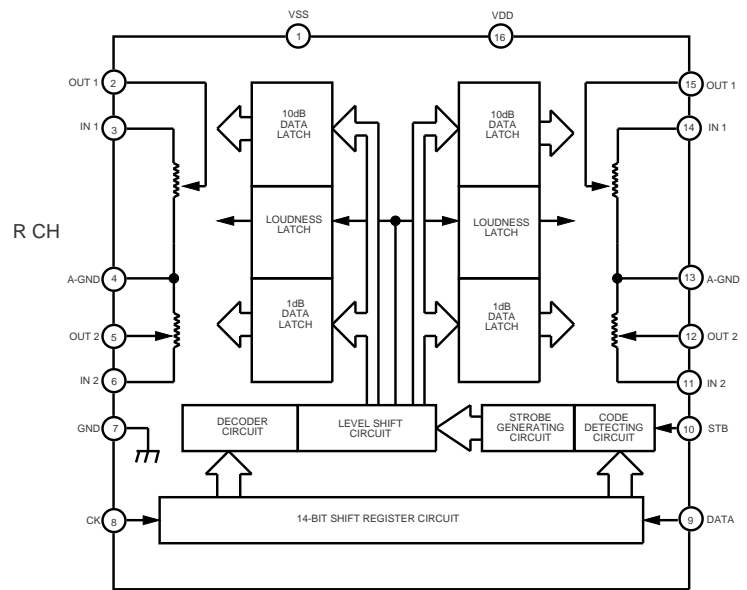

U403
Volume Control Block Diagram
TC9213P

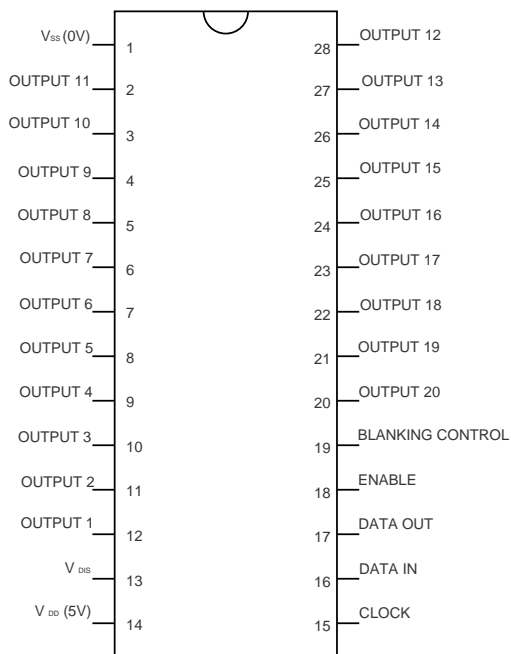

U200
VFD Driver Pin Out
MM58342

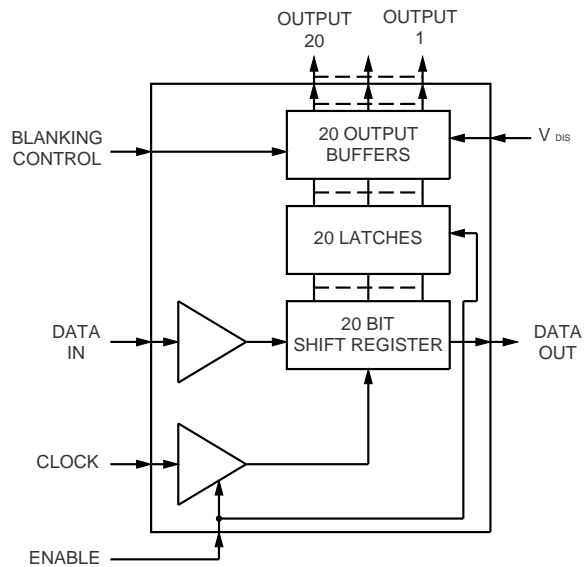

U200
VFD Driver Block Diagram
MM58342

Bose® Wave® Radio Series III

Note: The series III Bose Wave Radio can be distinguished from earlier series by the fact that it has a 9V backup battery. Earlier series used three AA size batteries.

SPECIFICATIONS AND FEATURES SUBJECT TO CHANGE WITHOUT NOTICE

BOSE®
Better sound through research®



BOSE CORPORATION
THE MOUNTAIN
FRAMINGHAM, MASSACHUSETTS USA 01701

P/N 191514 REV 04 11/2000: FOR TECHNICAL ASSISTANCE OR PART ORDERS, CALL 1-800-367-4008

SUPPLEMENT

Bose[®] Wave[®] Radio SERIES III

The following part numbers have changed or have been added to the BWR III. Insert this supplement into your BWR III service manual, part number 191514.

Reference Designator	Part Number	Description	Note
C3	149947-1R0H	1.0uf, 50V, EL, 85, 20%	Part added, see the figure below
C643, 647	133623-333	.033uF, 50V, X7R, 0805, 10%	220V only, part number change
-	145316	100V Line Cord 	Part number change
-	184599-01	220V Line Cord 	Part number change

 This part is critical for safety purposes. Failure to use a substitute replacement with the same safety characteristics as the recommended replacement part might create shock, fire and/or other hazards.

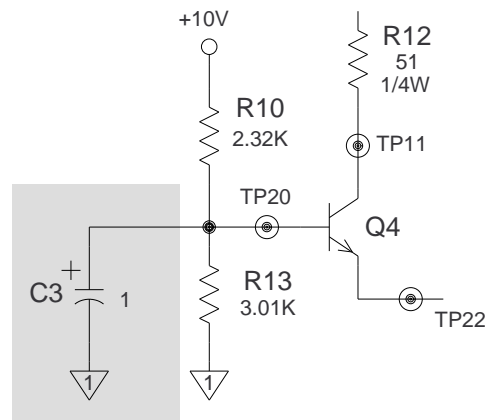

Schematic change to sheet 1

SUPPLEMENT

Bose® Wave® Radio SERIES III

The following parts are used in the 100V (Japanese) version of the BWR III. Insert this supplement into your BWR III service manual, part number 191514.

Reference Designator/ Item Number	Description	Part Number
TUNER	TUNER, FM, 76-90MHZ, 7V, JAPAN	188466-001
4	TWIDDLER, 57mm (RIGHT)	148704

Note: Refer to Figure 5 on page 17 of the BWR III Service Manual, part number 191514, for an exploded view showing the item call outs.

Contents

Safety Information	2
Supplement Overview	3
Electrostatic Discharge Sensitive (ESDS) Device Handling	3
Theory of Operation	4
Figure 1. Block Diagram.....	4
Part List Notes	5
Main Assembly Part List	5
Figure 2. Exploded View	6
Electrical Part List	7-14
Hotel Variant Packaging Part List	15
Figure 3. Packaging View	15
Figure 4. Hotel Wave® Radio Data Wire Dressing View	16
Figure 5. Security Bracket.....	16

PROPRIETARY INFORMATION

THIS DOCUMENT CONTAINS PROPRIETARY INFORMATION OF BOSE® CORPORATION WHICH IS BEING FURNISHED ONLY FOR THE PURPOSE OF SERVICING THE IDENTIFIED BOSE PRODUCT BY AN AUTHORIZED BOSE SERVICE CENTER OR OWNER OF THE BOSE PRODUCT, AND SHALL NOT BE REPRODUCED OR USED FOR ANY OTHER PURPOSE.

SAFETY INFORMATION

1. Parts that have special safety characteristics are identified by the  symbol on schematics or by special notes in the part lists. Use only replacement parts that have critical characteristics recommended by the manufacturer.

2. Make leakage current or resistance measurements to determine that exposed parts are acceptably insulated from the supply circuit before returning the unit to the customer. Use the following checks to perform these measurements:

A. Leakage Current Hot Check: With the unit completely assembled, plug the AC line cord directly into a 120V AC outlet. (Do not use an isolation transformer during this test.) Use a leakage current tester or a metering system that complies with American National Standards Institute (ANSI) C101.1 "Leakage Current for Appliances" and Underwriters Laboratories (UL) 1492 (71). With the unit's AC switch first in the ON position and then in the OFF position, measure from a known earth ground (metal water pipe, conduit, etc.) to all exposed metal parts of the unit (antennas, handle bracket, metal cabinet, screw-heads, metallic overlays, control shafts, etc.), especially any exposed metal parts that offer an electrical return path to the chassis. Any current measured must not exceed 0.5 milliamp. Reverse the unit's power cord plug in the outlet and repeat the test. **ANY MEASUREMENTS NOT WITHIN THE LIMITS SPECIFIED HEREIN INDICATE A POTENTIAL SHOCK HAZARD THAT MUST BE ELIMINATED BEFORE RETURNING THE UNIT TO THE CUSTOMER.**

B. Insulation Resistance Test Cold Check: (1) Unplug the power supply and connect a jumper wire between the two prongs of the plug. (2) Turn on the power switch of the unit. (3) Measure the resistance with an ohmmeter between the jumpered AC plug and each exposed metallic cabinet part on the unit. When the exposed metallic part has a return path to the chassis, the reading should be between 1 and 5.2 Meg ohms. When there is no return path to the chassis, the reading must be "infinite". If it is not within the limits specified, there is the possibility of a shock hazard, and the unit must be repaired and rechecked before it is returned to the customer.

CAUTION: THE BOSE® WAVE® RADIO CONTAINS NO USER SERVICEABLE PARTS. TO PREVENT WARRANTY INFRACTIONS, REFER SERVICING TO WARRANTY SERVICE STATIONS OR FACTORY SERVICE.

SUPPLEMENT OVERVIEW

This manual is a supplement to the Bose® Wave® Radio III service manual, part number 191514 REV 00. The information provided in this supplement should be used along with the Bose Wave Radio III service manual to service the hotel version of the Bose Wave Radio. Use the test, disassembly, and assembly procedures found in the Bose Wave Radio III service manual to service the Hotel Version of the Bose Wave Radio. It is not possible for a field service center to test the microprocessor for its ability to communicate with the hotel's computer. If the microprocessor needs to be tested for its ability to communicate, return the complete unit to Bose Factory Service for repairs.

ELECTROSTATIC DISCHARGE SENSITIVE (ESDS) DEVICE HANDLING

This unit contains ESDS devices. We recommend the following precautions when repairing, replacing or transporting ESDS devices:

- Perform work at an electrically grounded work station.
- Wear wrist straps that connect to the station or heel straps that connect to conductive floor mats.
- Avoid touching the leads or contacts of ESDS devices or PC boards even if properly grounded. Handle boards by the edges only.
- Transport or store ESDS devices in ESD protective bags, bins, or totes. Do not insert unprotected devices into materials such as plastic, polystyrene foam, clear plastic bags, bubble wrap or plastic trays.

THEORY OF OPERATION

Note: The following is a supplement to the theory of operation found in the BWR III service manual, part number 191514 REV 00.

7. Bose® Hotel Wave® Radio variant.

A data port (J6) provides for connection to a computer network for central control of the radio by the hotel. J6, pin1, transmits information about the radio settings to the computer. J6, pin3, receives signals from the computer to set the μ P (U201) and control the radio.

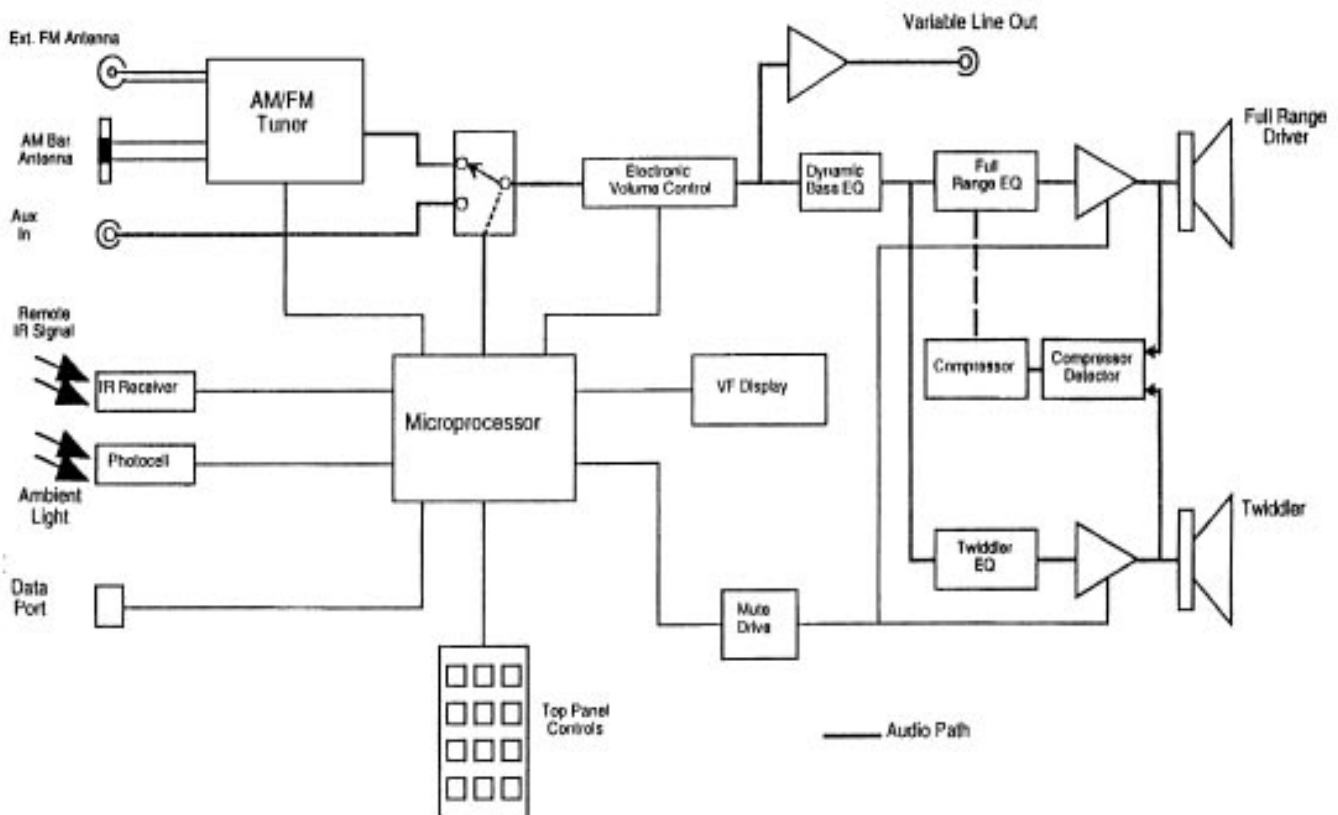



Figure 1. Block Diagram

PART LIST NOTES

1. This part is not normally available from customer service. Approval from the Field Service Manager is required before ordering.
2. The individual parts located on the PCB are listed in the part list.
3.  This part is critical for safety purposes. Failure to use a substitute replacement with the same safety characteristics as the recommended replacement part might create shock, fire and/or other hazards.
4. This PCB is part of a pallet. The pallet contains the Display PCB and the Main PCB. These two PCBs are manufactured and sold as a pallet.

MAIN ASSEMBLY PART LIST

(Refer to Figure 2)

Item Number	Description	Part Number	Note
1	GRILLE ASSY, BWR, WHT GRILLE ASSY, BWR, GRY	192280-001 192280-002	
2	TRANSFORMER, POWER, 120V TRANSFORMER, POWER, 100V TRANSFORMER, POWER, 220V-240V	187595-001 188465-001 188461-001	3 
3	TWIDDLER™, 57mm (LEFT)	145588	
4	TWIDDLER, 57mm (RIGHT)	148704	
5	CABLE, TWIDDLER, AW RECEIVER	172584	
6	CABLE, RIBBON, 21 CONDUCTOR	177256	
7	COVER, ASSY, SWITCH, WHT COVER, ASSY, SWITCH, GRY	180518-001 180518-002	
8	PAD, SW, ELASTOMETRIC, WHITE PAD, SW, ELASTOMETRIC, GRY	185180-001 185180-002	
9	PEDESTAL ASSEMBLY, BWRIII, BLACK	187621-001	
10	MATRIX ASSY, BWRIII, WHITE MATRIX ASSY, BWRIII, GRY	188453-001 188453-002	1
11	PCB ASSY, HWAVE, BWR, 120V PCB ASSY, HWAVE, BWR, 220V PCB ASSY, HWAVE, BWR, 100V	192334-001 192334-002 192334-003	1, 2, 4 (Display and Main PCB)
12	PCB ASSY, BWR, SWITCH	147212	
13	SCREW, HILO, 6x.5, PAN, XREC	175972-08	
14	SCREW, TAPP, 8-11x.625, PAN, XRC/S	172672-10	
15	PAD, FOAM ADHESIVE BACK	178945	
16	BATTERY, DOOR	187627-001	1
17	SHIELD, BOTTOM	171902	JAP/ VIDEO/ HWAVE
18	SHIELD, WOOFER, TOP	171903	JAP/ VIDEO/ HWAVE
19	CABLE, H-WAVE	190601	HWAVE
-	FOOT, RUBBER	188462-001	
-	FOAM, BATTERY COMPARTMENT	188458-001	

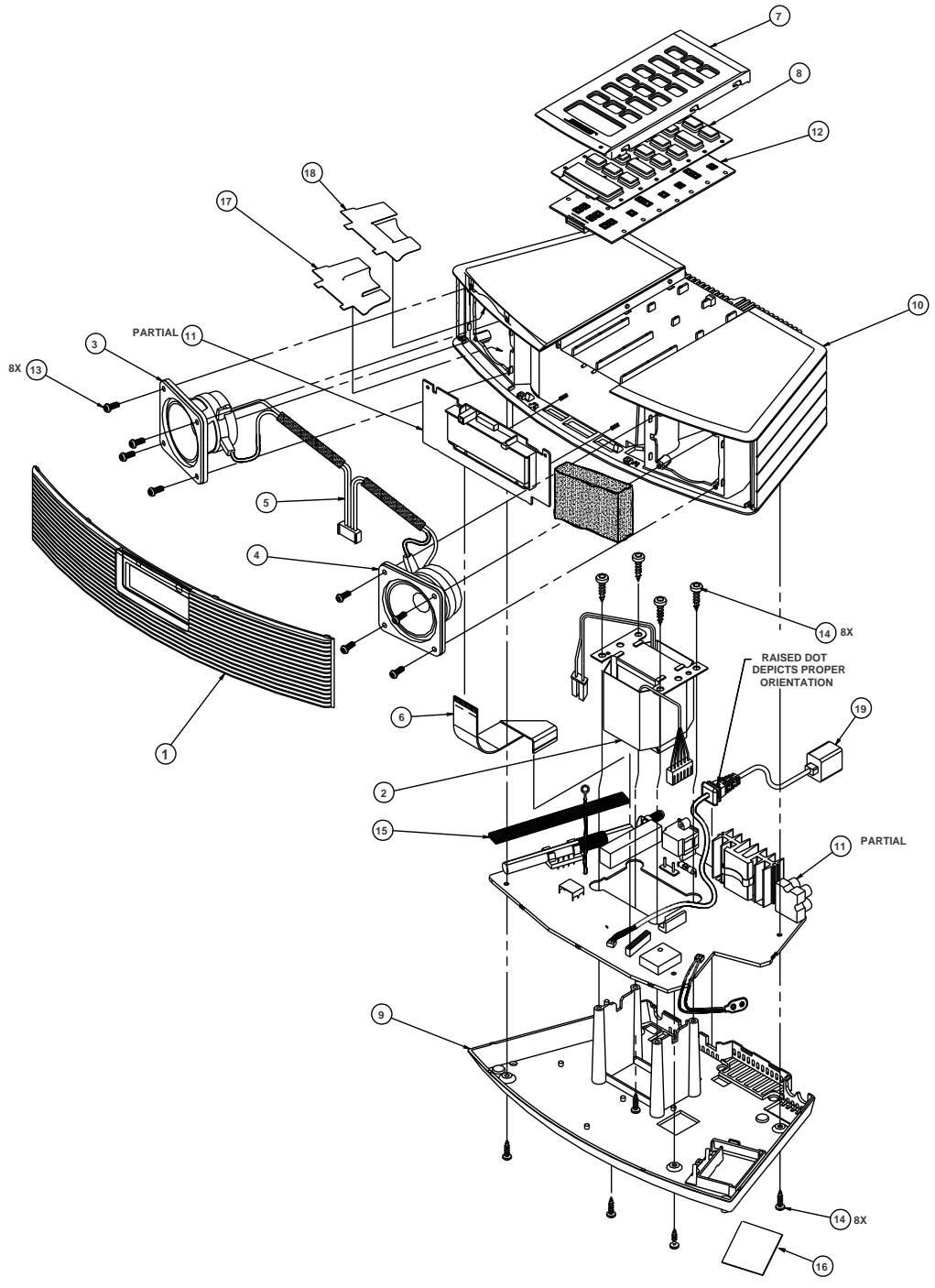



Figure 2. Exploded View

ELECTRICAL PART LIST

Resistors

Reference Designator	Description	Part Number	Note
R1	10MEG, CF, 1/2, 5%	121243-1511065	 3 100V/ 115V
R2, 422, 423, 443	3.32K, 0805, 1/10W, 1%	133625-3321	
R4, 278, 459	4.87K, 0805, 1/10W, 1%	133625-4871	
R5	270 Ω, 1210, 1/4W, 5%	187607-2715	
R6	10 Ω, FUSING, 1/2W, 5%	190759	 3
R7, 9, 230, 234, 235, 236, 238, 243, 248, 249, 251, 253, 254, 255, 273, ±274 , ¥275 , 279, 283, 400, 410, 413, 426, 452, 465, 468, 478, 487, 488, 619, 625, 630	10.0K, 0805, 1/10W, 5%	133626-1035	±220V/ 240V ¥115V/ 100V
R8, 200, 201, 202, 203, 205, 265, 266, ±271 , ¥272 , 281, 403, 484, 490, 601, 618, 623, 626	1.00K, 0805, 1/10W, 5%	133626-1025	±100V ¥115V, 220V/ 240V
R10, 604	2.32K, 0805, 1/10W, 1%	133625-2321	
R12	51 Ω, 1210, 1/4W, 5%	187607-5105	
R13, 474, 475, 610	3.01K, 0805, 1/10W, 1%	133625-3011	
R15	78.7K, 0805, 1/10W, 1%	133625-7872	
R16	270 Ω, 1W, 5%, 2512	181895-2700	
R204	390K, CHIP, 0805, 1/10W, 5%	133626-3945	
R206	33 Ω, 0805, 1/10W, 5%		
R208, 210, 609	330 Ω, 0805, 1/10W, 5%	133626-3315	
R209	820 Ω, 1210, 1/4W, 5%	187607-8215	
R211, 237, 406, 415, 451	2.00K, 0805, 1/10W, 5%	133626-2025	
R212	1K Ω, 2010, 1/2W, 5%	187608-1025	
R213, 214, 407, 421, 489, 492, 501, 502, 503, 504, 602, 629	100 Ω, CHIP, 0805, 1/10W, 5%	133626-1015	
R215, 217, 223, 224, 225, 226	68.0K, 0805, 1/10W, 5%	133626-6835	
R216, 620	4.75K, 0805, 1/10W, 1%	133625-4751	
R218, 219, 220, 221, 222, 263, 264	220K, 0805, 1/10W, 5%	133626-2245	

ELECTRICAL PART LIST

Resistors
(continued)

Reference Designator	Description	Part Number	Note
R227, 228, 244, 245, 247, 260, 261, 268, 277, 285, 427, 480, 493, 495, 638	100K, 0805, 1/10W, 5%	133626-1045	
R229, 242, 267, 269, 270, 282, 425, 428	1 MEG, 0805, 1/10W, 5%	133626-1055	
R231, 232, 233, 239, 240	6.80K, 0805, 1/10W, 5%	133626-6825	
R241	22 Ω , 0805, 1/10W, 5%	133626-2205	
R250	15K, CHIP, 0805, 1/10W, 5%	133626-1535	
R262, 276	150K, 0805, 1/10W, 5%	133626-1545	
R280	5.10K, 0805, 1/10W, 5%	133626-5125	
R286	120 Ω , 0805, 1/10W, 5%	133626-1215	
R287, 434, 439, 453, 616	19.6K, 0805, 1/10W, 1%	133625-1962	
R288, 496, 498, 603, 606, 639	3.90K, 0805, 1/10W, 5%	133626-3925	
R289	180K, CHIP, 0805, 1/10W, 5%	133626-1845	
R401, 402	21.0K, 0805, 1/10W, 1%	133625-2102	
R404, 411	6.19K, CHIP, 0805, 1/10W, 1%	133625-6191	
R405	2.49K, 0805, 1/10W, 1%	133625-2491	
R408	196 Ω , 0805, 1/10W, 1%	133625-1960	
R409, 412	332 Ω , CHIP, 0805, 1%	133625-3320	
R414	88.7K, 0805, 1/10W, 1%	133625-8872	
R416, 418, 444	22.1K, 0805, 1/10W, 1%	133625-2212	
R417, 456, 485	15.4K, 0805, 1/10W, 1%	133625-1542	
R419, 437, 466	750 Ω , 0805, 1/10W, 1%	133625-7500	
R420	26.7K, 0805, 1/10W, 1%	133625-2672	
R424	21.5K, 0805, 1/10W, 1%	133625-2152	
R429, 470	30K, CHIP, 0805, 1/10W, 5%	133626-3035	
R430, 432, 460	1.21K, 0805, 1/10W, 1%	133625-1211	
R431, 446	100 Ω , 0805, 1/10W, 1%	133625-1000	
R433, 628	3.48K, 0805, 1/10W, 1%	133625-3481	

ELECTRICAL PART LIST

Resistors
(continued)

Reference Designator	Description	Part Number	Note
R435	732 Ω , 0805, 1/10W, 1%	133625-7320	
R436, 455, 463	4.22K, 0805, 1/10W, 1%	133625-4221	
R438	12.1K, 0805, 1/10W, 1%	133625-1212	
R440	590 Ω , 0805, 1/10W, 1%	133625-5900	
R441	34.8K, 0805, 1/10W, 1%	133625-3482	
R442	42.2K, 0805, 1/10W, 1%	133625-4222	
R445	23.2K, 0805, 1/10W, 1%	133625-2322	
R447	1.02K, 0805, 1/10W, 1%	133625-1021	
R448	267 Ω , 0805, 1/10W, 1%	133625-2670	
R450, 600	49.9 Ω , 0805, 1/10W, 1%	133625-49R9	
R454	1.78K, 0805, 1/10W, 1%	133625-1781	
R458	13.3K, 0805, 1/10W, 1%	133625-1332	
R464	23.7K, 0805, 1/10W, 1%	133625-2372	
R467	110K, 0805, 1/10W, 1%	133625-1103	
R471	36.5K, 0805, 1/10W, 1%	133625-3652	
R473	4.64K, 0805, 1/10W, 1%	133625-4641	
R476	4.99K, 0805, 1/10W, 1%	133625-4991	
R479	4.02K, 0805, 1/10W, 1%	133625-4021	
R483, 486, 491, 607, 624	47.0K, 0805, 1/10W, 5%	133626-4735	
R497, 499	7.50K, 0805, 1/10W, 1%	133625-7501	
R605	499 Ω , CHIP, 0805, 1/10W, 1%	133625-4990	
R608	2.26K, 0805, 1/10W, 1%	133625-2261	
R611	20 Ω , 0805, 1/10W, 5%	133626-2005	
R615	10K Ω , POT, RTRY, 30%, 1/2W, TRIM	177494-103	
R617	5K Ω , POT, RTRY, 30%, 1/2W, TRI	177494-502	
R621	1.60K, 0805, 1/10W, 5%	133626-1625	

ELECTRICAL PART LIST

Resistors (continued)

Reference Designator	Description	Part Number	Note
R622	620 Ω , 0805, 1/10W, 5%	133626-6215	
R627	47.0K, 0805, 1/10W, 5%	133626-4735	
R632	30.1 Ω , 0805, 1/10W, 1%	133625-30R1	
R634, 636	3.3K, CHIP, 0805, 5%	133626-3325	
R635, 637	4.3K, CHIP, 0805, 1/10W, 5%	133626-4325	

Capacitors

Reference Designator	Description	Part Number	Note
C2, 5, 6, 7, 8, 12, 13, 205, 206, 247, 601, 606, 611, 619, 620, 633, 639, 441, 444, 637, 642, 643 , 644, 647	.047uF, 0805, X7R, 50V, 10%	133623-473	115V
C3, 614, 615, 617	1.0uF, EL, 85, 50V, 20%	149947-1R0H	
C9	10KuF, EL, 105, 25V, 20%	171555	
C11, 16	470uF, EL, 85, 35V, 20%	149948-471V	
C14, 19, 437, 438, 607	.47uF, EL, 85, 50V, 20%	149947-R47H	
C15, 246, 451, 600, 618, 640	47uF, EL, 85, 16V, 20%	149947-470C	
C17, 250, 255 , 256 , 401, 404, 410, 413, 414, 436, 442, 445, 455, 456, 460, 461, 602, 646, 654, 655, 656	1000pF, 0805, X7R, 50V, 10%	133623-102	HWAVE
C18, 439, 638	100uF, EL, 85, 16V, 20%	149947-101C	
C200, 202	220uF, EL, 85, 6.3V, 20%	149947-221J	
C209, 235, 238, 240, 241, 251, 242, 243, 245, 632, 635, 648, 649	100pF, 0805, COG, 50V, 5%	133622-101	
C224, 225, 403, 416, 417	.1uF, BOX, 85, 50V, 5%	137127-104	
C227, 228, 229, 230, 231, 232	470pF, 0805, COG, 50V, 5%	133622-471	
C233, 249, 622	3.3uF, EL, 85, 50V, 20%	149947-3R3H	
C234	2.2uF, MONO, 1206, Y5V, 16V, 80%	178212-225	

ELECTRICAL PART LIST

Capacitors (continued)

Reference Designator	Description	Part Number	Note
C236, 237	39pF, 0805, COG, 50V, 5%	133622-390	
C239, 407, 448, 457, 458, 605, 630, 634	.01uF, 0805, X7R, 50V, 10%	133623-103	
C244, 629	.33uF, EL, 85, 50V, 20%	149947-R33H	
C248, 604	.1uF, 1206, X7R, 25V, 5%	131754-104	
C400	.027uF, BOX, 85, 63V, 5%	137127-273	
C402	.056uF, BOX, 85, 63V, 5%	137127-563	
C405, 406	.12uF, BOX, 85, 50V, 5%	137127-124	
C408, 411, 412, 443, 449, 450, 612, 621, 623, 624, 626, 650, 652	10uF, EL, 85, 25V, 20%	149947-100E	
C409, 432, 433	.47uF, BOX, 85, 50V, 5%	137127-474	
C418, 420, 643, 647	.033uF, BOX, 85, 63V, 5%	137127-333	100V, 220V/ 240V
C419, 421, 424, 425	.012uF, BOX, 85, 100V, 5%	137127-123	
C422	.0068uF, BOX, 85, 100V, 5%	137127-682	
C423, 426	.27uF, BOX, 85, 50V, 5%	137127-274	
C427, 428	.022uF, BOX, 85, 100V, 5%	137127-223	
C429, 430	.039uF, BOX, 85, 63V, 5%	137127-393	
C431	.0047uF, BOX, 85, 100V, 5%	137127-472	
C434	330pF, 0805, COG, 50V, 5%	133622-331	
C435	10uF, EL, BP, 85, 20%, 16V	188459-100C	
C459, 616	4.7uF, EL, 85, 50V, 20%	149947-4R7H	
C603	6.8pF, CHIP, 0805, 50V, 5%	133622-6R8	
C609	20pF, TRIM, NPO, 100V	148768-T200	
C610	430pF, 0805, COG, 50V, 2%	177269-431	
C625	.022uF, 0805, X7R, 50V, 10%	133623-223	
C631	2.2uF, EL, BP, 85, 50V, 20%	147522-2R2	

ELECTRICAL PART LIST

Capacitors (continued)

Reference Designator	Description	Part Number	Note
C636, 641	33pF, 0805, COG, 50V, 5%	133622-330	
C645	1.0uF, EL, BP, 85, 50V, 20%	147522-1R0	
C651, 653	1800PF, 0805, COG, 50V, 5%	133622-182	

Diodes

Reference Designator	Description	Part Number	Note
D1, 5	SMT, S1G	178380-4	
D2, 201, 202, 203	SWITCHING, 75V, 200mA	136603	
D3, 401	DUAL, SOT-23, BAV70	147249	
D200	SENSOR, LIGHT, VISIBLE	187629-001	
D205	ZEN, 6.2V, .5W, 5%, SOD-123	174265-5234	
D206, 207, 208, 400, 403, 404, 601, 602, 603	DUAL, SOT-23, BAV99	147239	
D210, 211	ZENER, SMT, 5.1V, IN5231	174265-5231	
D600	VARACTOR, DUAL, 20V, 50mA	177495-5	
BR1	RECTIFIER, BRIDGE, 100V	187611-001	 3

Transistors

Reference Designator	Description	Part Number	Note
Q1, 202, 400, 401, 404, 405	BPLR, P, 55V, 150mA, SOT23	134743	
Q3, 201, 206, 207, 403, 407, 410	BPLR, N, 55V, 150mA, SOT23	134741	
Q4	BPLR, N, 50V, 500MA, TO-92	187594-001	
Q200	SENSOR, IR DETECTING	170083	
Q204, 605, 606	BPLR, N, 50V, 100mA, SOT23	146817	
Q408, 409, 607	BPLR, P, 50V, 100mA, SOT23	146818	
Q603	NPN, SOT, MMBT3904	146819	
Q604	JFET, N, 40V, 6mA, TO-92	147561-3	

ELECTRICAL PART LIST

Integrated Circuits

Reference Designator	Description	Part Number	Note
U1	VOLT, REG, 10V, POS	178352-10	
U200	IC, VFD DRIVER, DIP-28, MM58342	146813	
U201	UC, HWAVE, PROGR	192324	
U202	VOLTAGE COMPARATOR, LM339	187618-001	
U400, 408	OP AMP, SNGL, SO-8, CA3080	187617-001	
U401	QUAD POWER AMP, MW15	180050	
U402	MULTIPLEXER, HCF4052BEY	187620-001	
U403	VOLUME CNTRL, DIP-16, TC9213P	147622	
U404, 405	QUAD OP AMP, TLO74D, SOIC	186112	
U406	OP AMP, DUAL, SO-8, NJM4556	148598	
U407	OP AMP, DUAL, TL072	187619-001	
U600	AM/FM TUNER, SO-20 LA1836	187600-001	
U601	PLL FREQ SYNTH, DIP-20	147527	

Inductors





Reference Designator	Description	Part Number	Note
L2	SMT, LEM4532, 10uH	178370-100	
L3, 4	2.2uH, COM MODE	187598-2R2	 3
L600	OSCILLATOR	180647	
L601	SMT, LEM4532, 100uH	178370-101	
L602, 603	FILTER, STEREO MPX, SINGLE TUNED	187624-001	

Miscellaneous

Reference Designator	Description	Part Number	Note
TUNER	FM, 3 GANG, 7V FM, 76-90MHZ, 7V FM, 4GANG, 7V	180995 188466-001 184589	US JAPAN EURO
CF208, 601	RESONATOR, CERAMIC, 456KHZ	187604-001	
CF600, 604	FILTER, CER, 10.7 MHZ, 180+-20KHZ	179028	

ELECTRICAL PART LIST

Miscellaneous
(continued)

Reference Designator	Description	Part Number	Note
T600, 601	DETECTOR, FM, SINGLE TUNED	187602-001	
X200	RESONATOR, CER, 4MHz	147534	
X600	CRYSTAL, QUARTZ, 7.2MHz, 50PPM	147223	
F1	SLOBLO .75A, 250, .60x0.19 .5A, 250V, .60x.19	135677-04 135677-03	 3 100V/ 115 220V/ 240V
DISPLAY	VFD	147226	
J1	CONN, HOUSING, AC, 2 POS, FEMALE	146563 145306	 3 100V/ 115V 220V/ 240V
J2	CONN, HEADER, 2 POS, 8MM	178742-2	 3
J3	CONN, HEADER, INLINE, PCB MNT, 6P	133220-06	 3
J4	CONN, HEADER, TOP ENTRY, 21 POS	177257-21	
J5	CABLE, BATTERY/ ADAPTER, 9 VOLT	187610-001	
J6	CONN, HEADER, RTANG, 2.5mm, 3 POS	145402-03	
J200	CONN, HEADER, SHIELDED, 10 POS	147246-10	
J201	CONN, HEADER, SIDE ENTRY, 21 POS	177258-21	
J400	CONN, HEADER, INLINE, PCB MNT, 4P	133220-04	
J401	CONN, HOUSING, PHONO, QUAD, 8 POS	147227	
J600	CONN, FM ANTENNA	178354 179271	US/ JAPAN EURO
FOR/MICRO	SHIELD, IC, BWR	188468-001	
FOR IC	SHIELD, IC, BWR	178944	
AM-ANT	ANTENNA, FERRITE BAR	177268	
BUZZ1	SOUNDER, PIEZOELECTRIC	149562	
	HEATSINK	177562	
	HOLDER, DISPLAY, BWR	175357	
	CLIP, SPRING	142864	
HEATSINK	SCREW, TAPP, M3.5x0.6x10, PAN, TRX	140447-10	

HOTEL VARIANT PACKAGING PART LIST

Item Number	Description	Part Number	Note
1	BWR REMOTE, EXTENDED RANGE	182433	
2	BATTERY, LITHIUM, CR2032 or DL2032	180991	⚠ 3
3	BATTERY, CARBON, 9 VOLT	187609-001	
4	LINE CORD, DETACHABLE	172045 184599-01 134726 145316	⚠ 3 US EUR AUS JAPAN
5	CARTON, RSC, BWR	183793	
6	PACKING, END CAP, BWR, THERMOFORM	183481	
7	BAG, POLY, 17.5x17.1x4 MIL, SHIP	149205	
8	POLYBAG, 4x12, 3 MIL	144348	

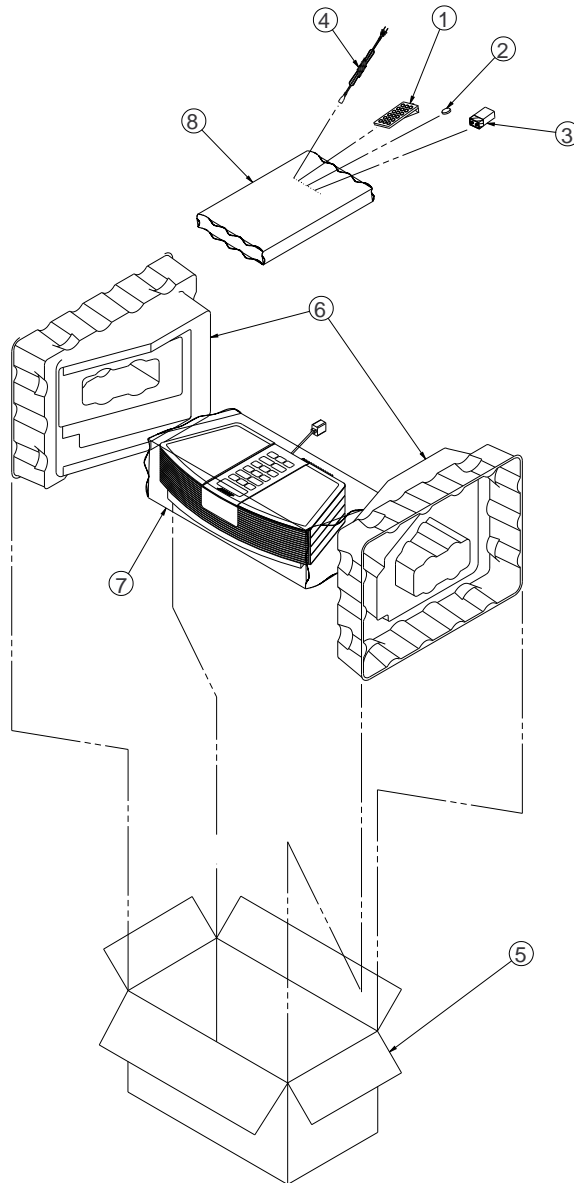

Figure 3. Packaging View

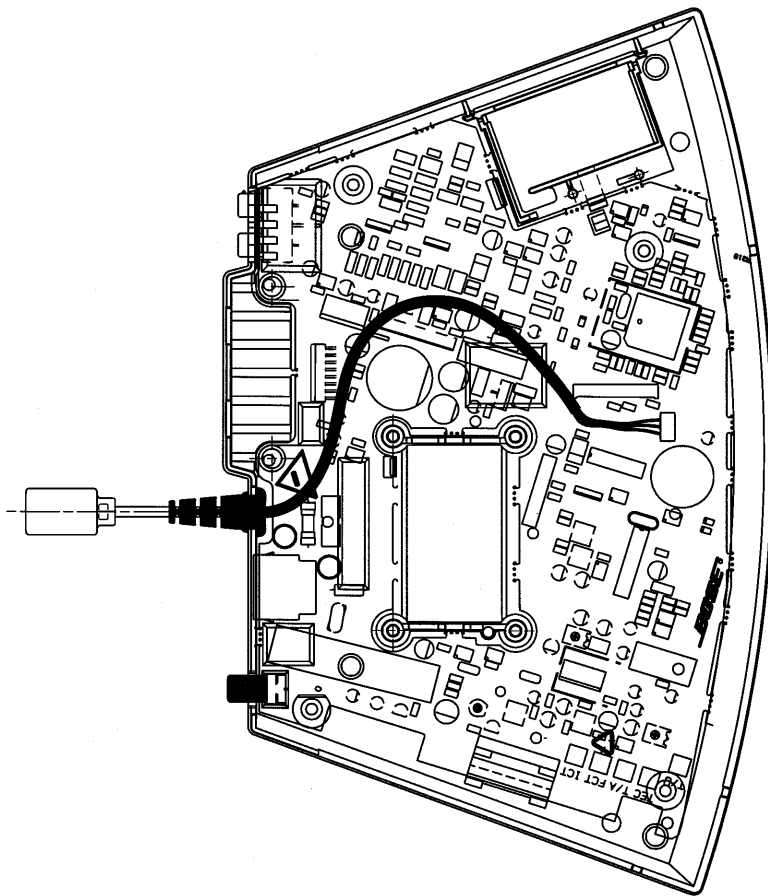

Figure 4. Hotel Wave® Radio Data Wire Dressing View

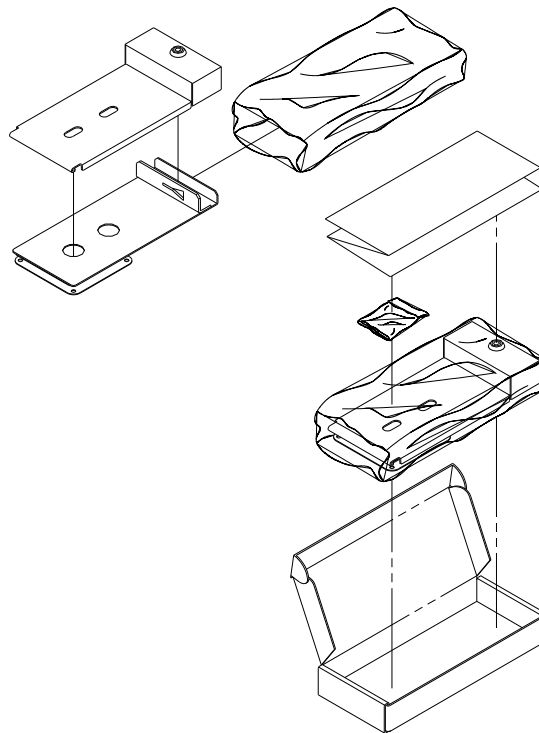

Figure 5. Security Bracket
Accessory Product code 010126

SUPPLEMENT

Hotel Variant Bose[®] Wave[®] Radio Series III

Note: The hotel variant of the Bose Wave Radio can be distinguished from other Bose Wave Radios by the fact that it has a data connector in the rear of the unit.

SPECIFICATIONS AND FEATURES SUBJECT TO CHANGE WITHOUT NOTICE

BOSE®
Better sound through research®

BOSE CORPORATION
THE MOUNTAIN
FRAMINGHAM, MASSACHUSETTS USA 01701

P/N 191514-S3 REV 00 08/97: FOR TECHNICAL ASSISTANCE OR PART ORDERS, CALL 1-800-367-4008

SUPPLEMENT

**Bose[®] Wave[®] Radio
Series III**

The table below lists components whose values have changed in the Bose Wave Radio Series III. Insert this supplement into the Bose Wave Radio service manual, part number 191514.

Reference Designator	Description	Part Number
C227, 228, 229, 230, 231	470pF, 0805, COG, 50V, 5%	133622-471
C252, 253, 254	330pF, 0805, COG, 50V, 5%	133622-331

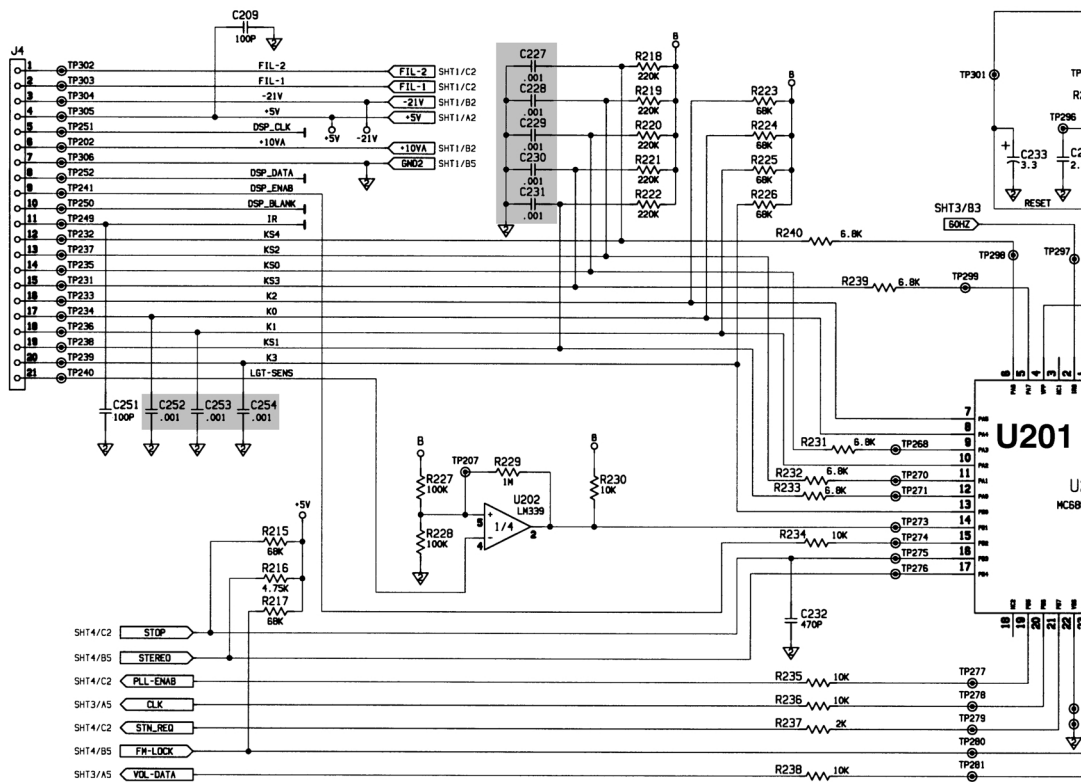

SUPPLEMENT

BOSE® WAVE® RADIO III CONNOISSEUR E D I T I O N

The table below lists the parts that are used on the Bose Wave Radio III Connoisseur Edition. The table lists all the parts that are different from the regular production version of the BWR III. The difference between the PCB used in the regular production BWR III and the PCB used in the Connoisseur Edition is the gold plated RCA and FM antenna connectors. The item numbers refer to Figure 5 in the BWR III service manual, part number 191514. Insert this supplement into the Bose Wave Radio III service manual, part number 191514 Rev 00.

Item Number	Description	Part Number
1	Grille Assy, BWR, Platinum	192280-004
7	Cover Assy, Switch, Warm Brown	180518-005
8	Pad, Switch, Elastomeric, Dk Brown	185180-006
10	Matrix, Assy, BWR III, Platinum	188453-004
11	PCB Assy, BWR III, 120V, Platinum	187615-041
-	Conn, RCA, Quad, Gold Plated	193600
-	Conn, FM Antenna, US, Gold Plated	193601

SUPPLEMENT

Bose Wave[®] Radio III

Later versions of the BWR III were manufactured with the PCB 192330. The component differences between the PCB 192330 and the PCB 187606 are listed in the table below. There are two different protection circuits used in the BWR III. The components within the dotted outline on the schematic below comprise one version of the protection circuit. The other version is just the polyswitch R500, part number 147185. The polyswitch is installed in the Twiddler[®] wire harness. Some units will have one version of the protection circuit and some will have both versions of the protection circuit. Use the schematics found in the Hotel Variant supplement, part number 191514-S3 REV 00, to service the units that have the PCB 192330. Insert this supplement into the BWR III service manual, part number 191514 REV 00.

Reference Designator	Description	Part Number	Note
R410, 413, 426	10.0 k, 5%, 1/10 W, 0805	133626-1035	Part added
R427, 638	100 k, 5%, 1/10 W, 0805	133626-1045	Part added
R429	30.0 k, 5%, 1/10 W, 0805	133626-3035	Part added
R433	3.48 k, 1%, 1/10 W, 0805	133625-3481	value change
R608	2.26 k, 1%, 1/10 W, 0805	133625-2261	value change
R615	10 k, POT, 30%, 1/2W	177494-103	value change
R617	5 k, POT, 30%, 1/2W	177494-502	value change
R639	3.9 k, 5%, 1/10 W, 0805	133626-3925	Part added
C435	10 uF, 16 V, 20%, 85, BP, EL	188459-100C	Part added
C603	6.8 pF, 5%, 50 V, COG, 0805	133622-6R8	value change
Q400, 401	SOT23, 150 mA, 55V, P, BPLR	134743	Part added
Q407	SOT23, 150 mA, 55V, N, BPLR	134741	component change
Q408	2SA1341, 50 V, P	146818	Part added

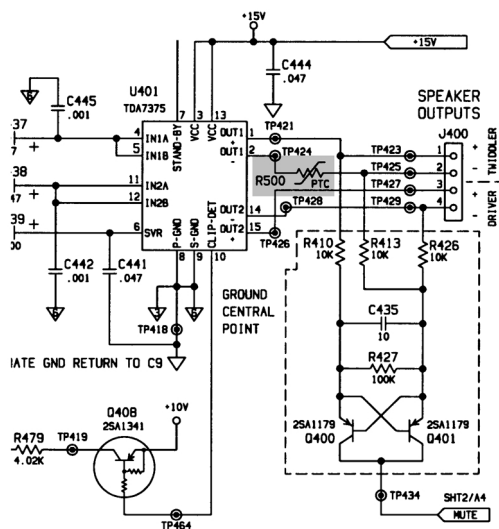

SUPPLEMENT

**Bose[®] Wave[®] Radio
Series III**

The part listed below has changed. Make a note in your Bose Wave Radio III service manual part number 191514.

Reference Designator	Description	Part Number
U401	Power Amp, MW15, TDA7375A	250117

ECN 25372

 NO PART
 187606 REV 2 SE

ASSY. #	DESCRIPTION	REV
187606	OPERATION VISUAL STANDARD	02
DOC. #	PC	

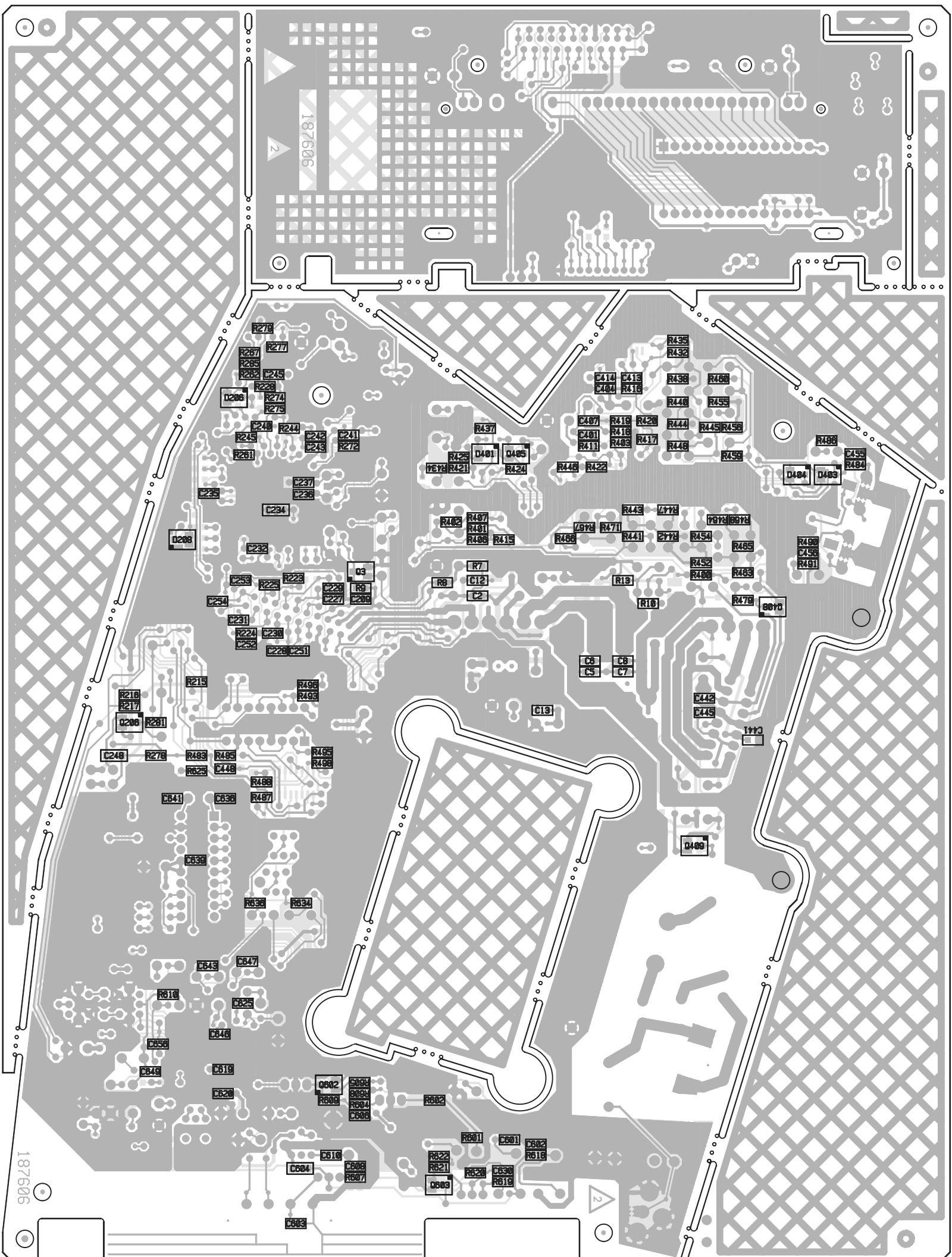

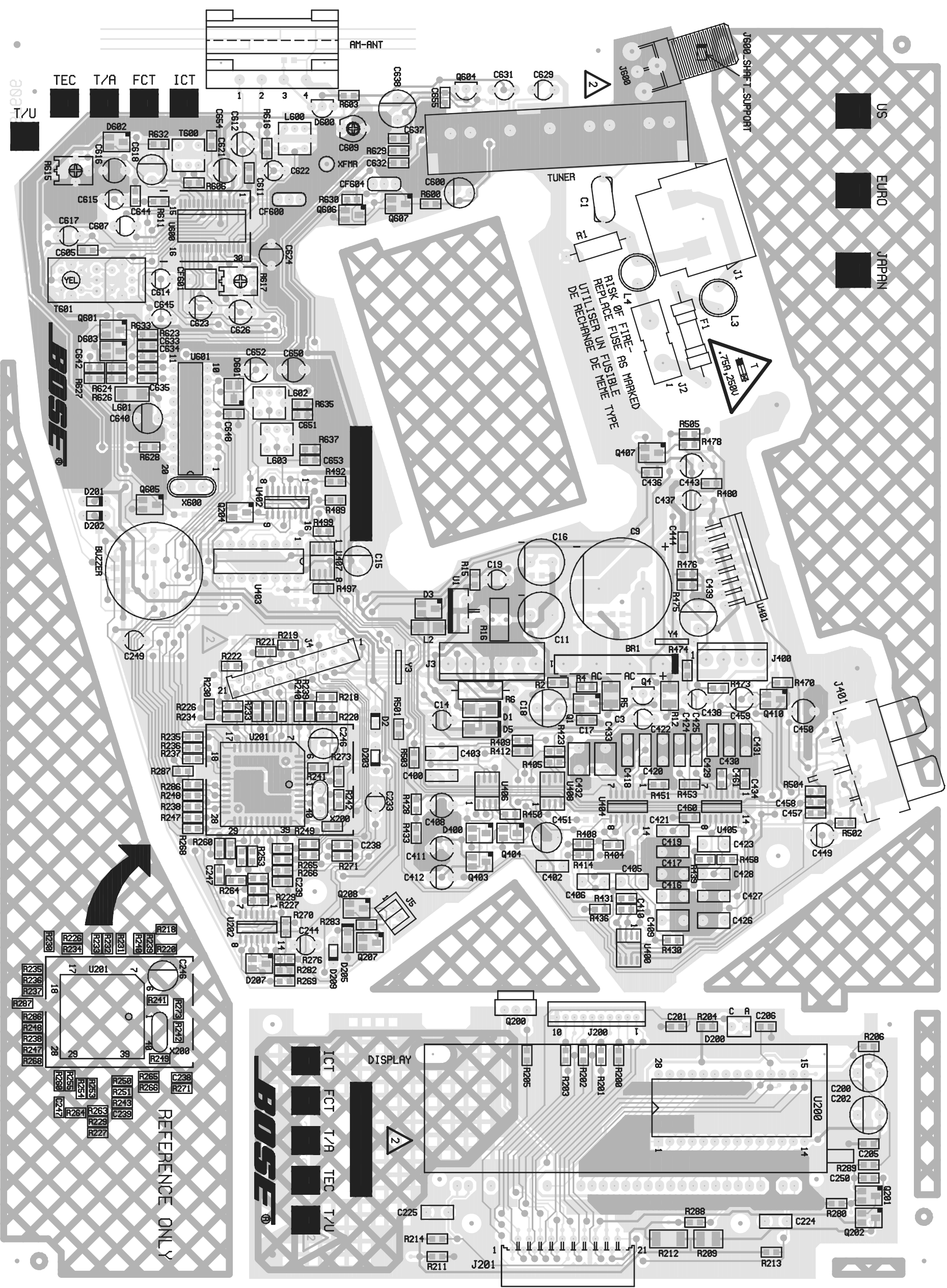

REFERENCE ONLY

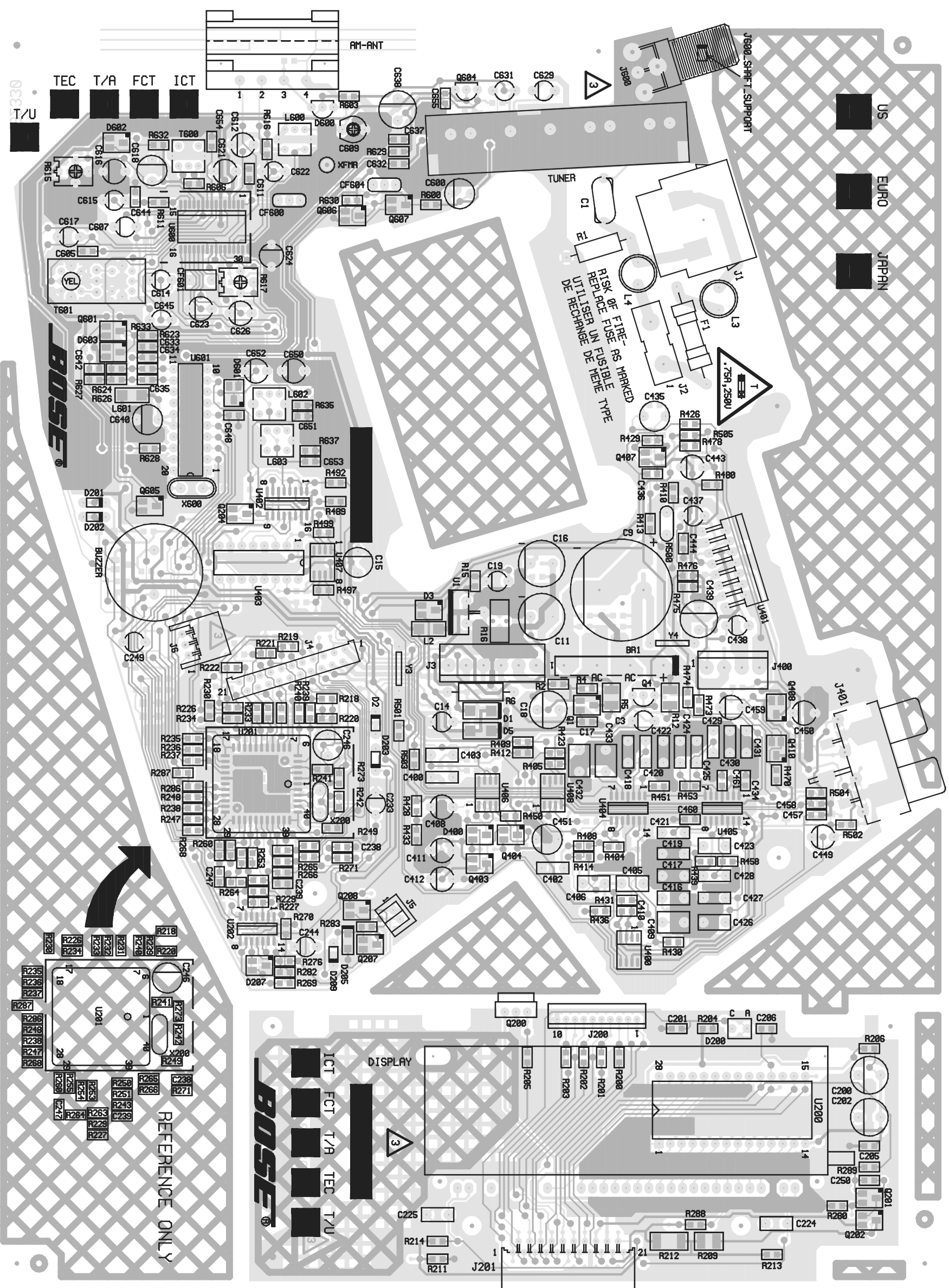

■ = NO PART

ASSY. #	REV	01
198160		
DESCRIPTION	WAVE RADIO	
OPERATION	*	
DOC. #	PG	

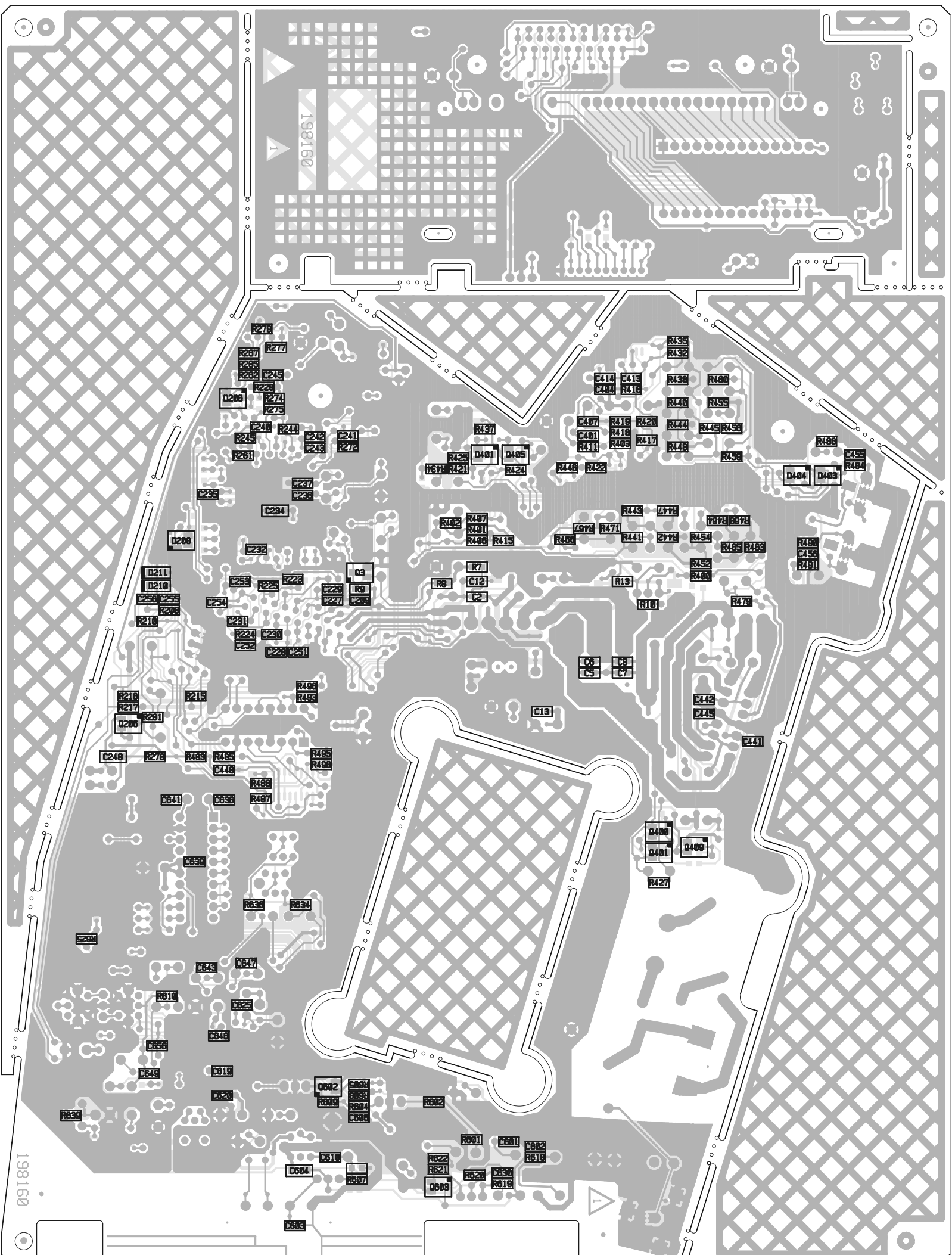

DISPLAY BOARD

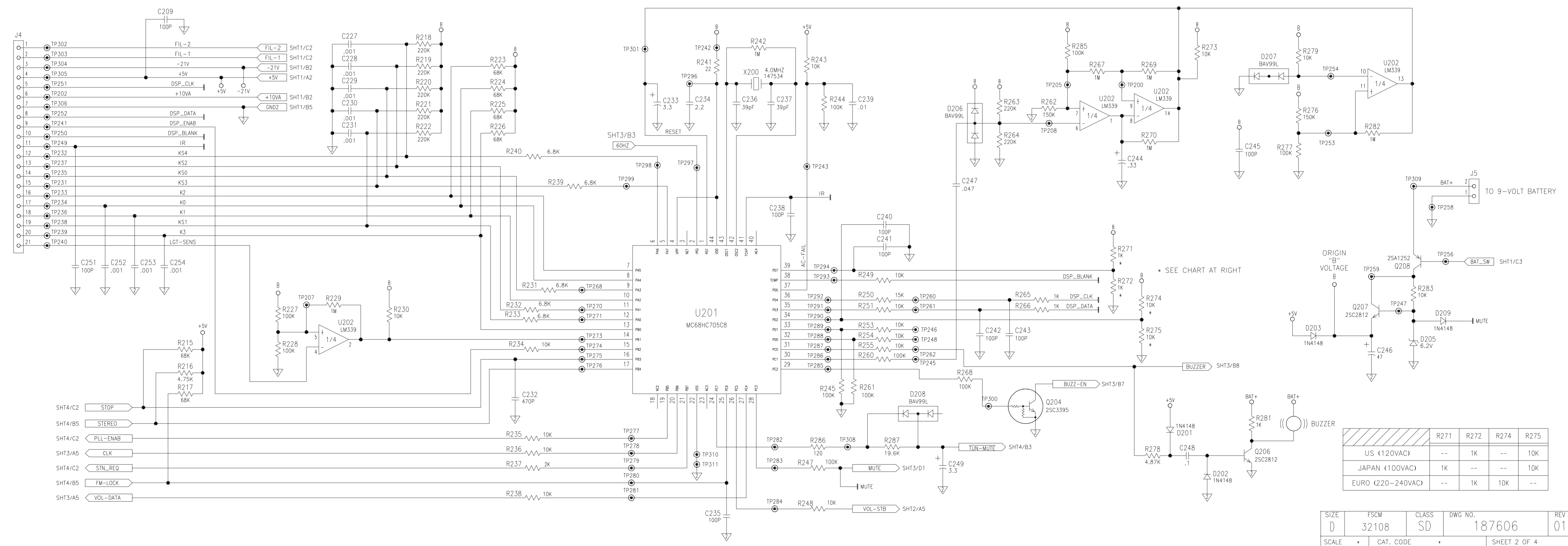
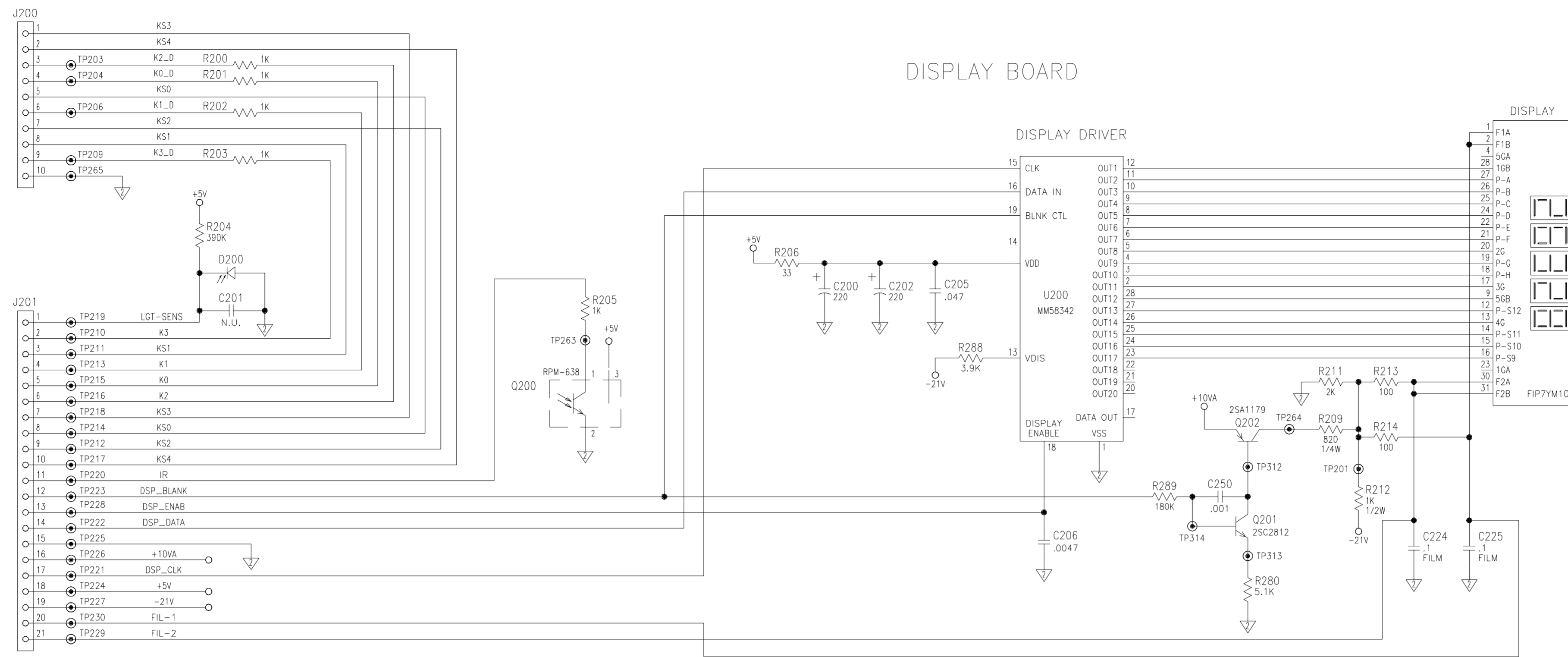

* SEE CHART AT RIGHT

	R271	R272	R274	R275
US (120VAC)	--	1K	--	10K
JAPAN (100VAC)	1K	--	--	10K
EURO (220-240VAC)	--	1K	10K	--

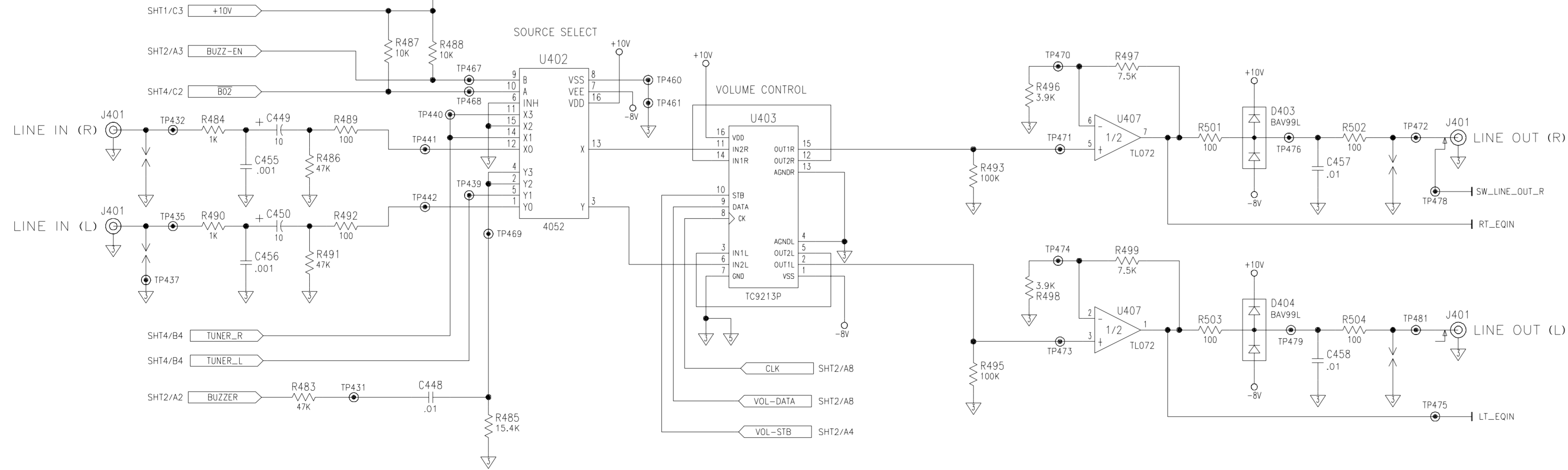
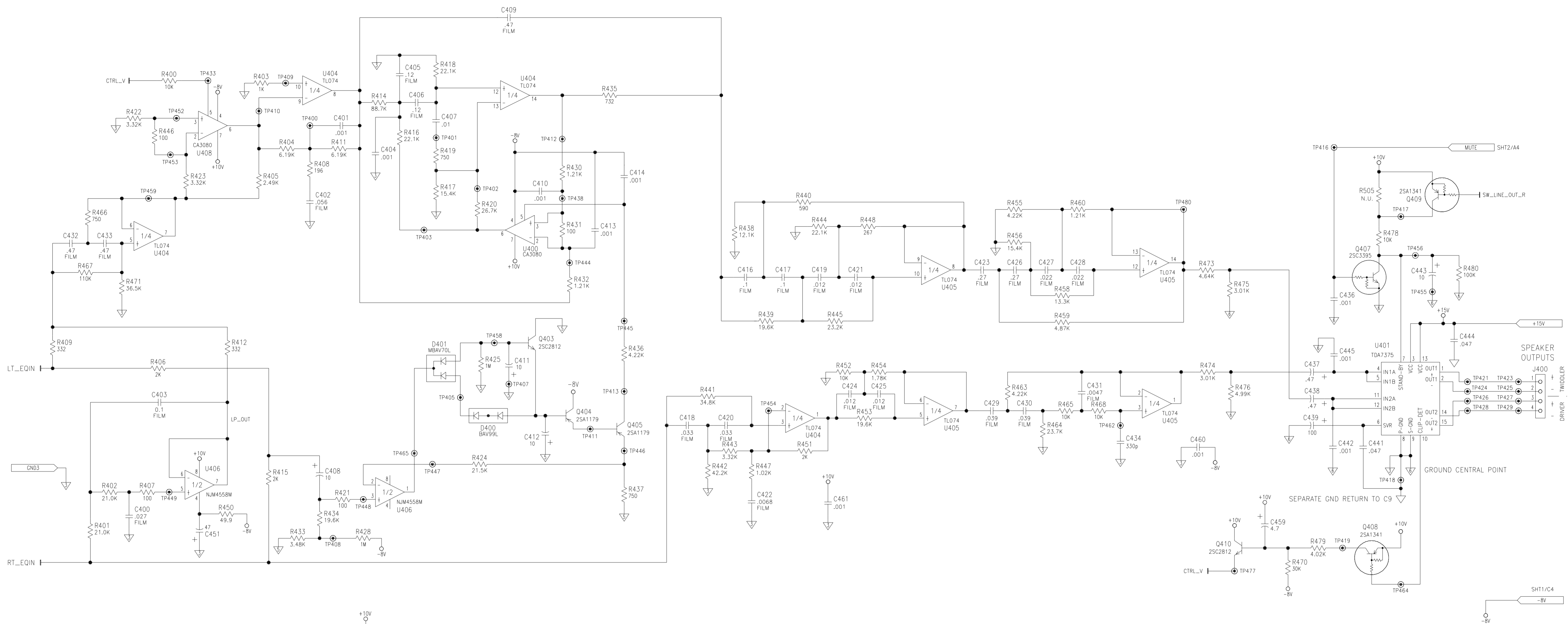

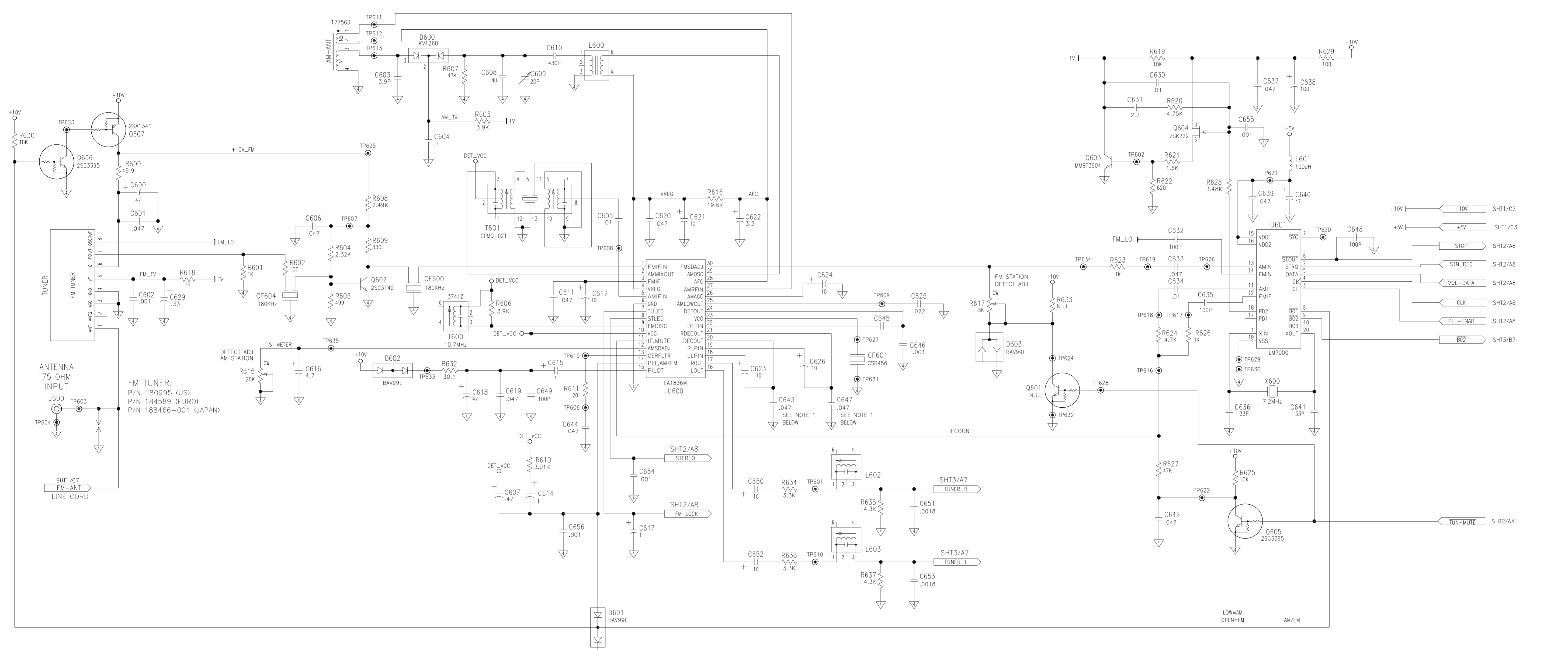

NOTE 1: FOR EUROPE AND JAPAN VERSIONS: C643, C647 = .033uF

CLASS	DWG NO.	SN	1		
SD	192330	1			
REVISIONS					
REV	DESCRIPTION	CHK	ENG	DATE	
02	ECN 22729 CHG'D R429	R.O.	L.A.	9/15/97	
03	ECN 23383 ADD R500,PROTECTION CKT NOT USED(SHT 3)	JM	L.A.	12/8/97	

⚠ DENOTES CRITICAL COMPONENTS.
REPLACE ONLY WITH IDENTICAL BOSE PARTS.

- C1: P/N 183627-330 (100VAC/115VAC)
- R1: P/N 121243-1511065 (100VAC/115VAC)
- L3,L4: P/N 187598-2R2 (100VAC/115VAC/220VAC-240VAC)
- BR1: P/N 187611-100 (100VAC/115VAC/220VAC-240VAC)
- T1: P/N 188465-001 (100VAC)
- P/N 187595 (115VAC)
- P/N 188461-001 (220VAC-240VAC)
- J1: P/N 146563 (100VAC/115VAC)
- P/N 145306 (220VAC-240VAC)
- J2: P/N 178742-2 (100VAC/115VAC/220VAC-240VAC)
- J3: P/N 133220-6 (100VAC/115VAC/220VAC-240VAC)
- F1: P/N 135677-04 (100VAC/115VAC)
- P/N 135671-02 (220VAC-240VAC)
- LINE CORD ASSEMBLY: P/N 172045 (US)
- P/N 184599 (EUR)
- P/N 134725 (UK, SINGAPORE)
- P/N 134726 (AUS)
- P/N 145316 (JAPAN)

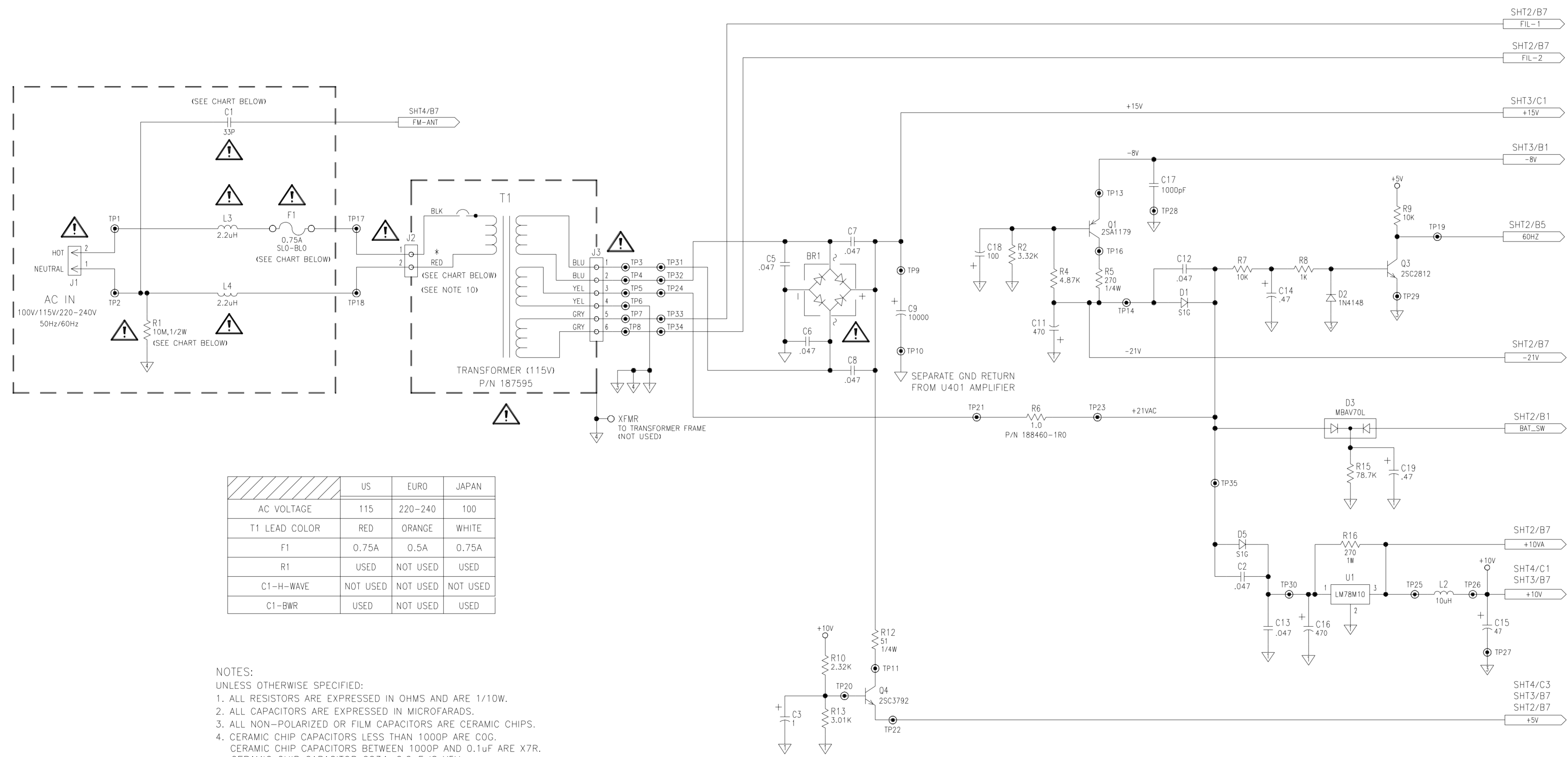

	US	EURO	JAPAN
AC VOLTAGE	115	220-240	100
T1 LEAD COLOR	RED	ORANGE	WHITE
F1	0.75A	0.5A	0.75A
R1	USED	NOT USED	USED
C1-H-WAVE	NOT USED	NOT USED	NOT USED
C1-BWR	USED	NOT USED	USED

NOTES:

- 1. ALL RESISTORS ARE EXPRESSED IN OHMS AND ARE 1/10W.
- 2. ALL CAPACITORS ARE EXPRESSED IN MICROFARADS.
- 3. ALL NON-POLARIZED OR FILM CAPACITORS ARE CERAMIC CHIPS.
- 4. CERAMIC CHIP CAPACITORS LESS THAN 1000P ARE COG.
CERAMIC CHIP CAPACITORS BETWEEN 1000P AND 0.1uF ARE X7R.
CERAMIC CHIP CAPACITOR C234, 2.2uF IS Y5V.
- 5. LM393 (8 PIN): +10V IS PIN 8, GND4 IS PIN 4.
- 6. LM339 (14 PIN): B IS PIN 3, GND2 IS PIN 12.
- 7. TL074 (14 PIN): +10V IS PIN 4, -8V IS PIN 11.
- 8. NJM4558M (8 PIN): +10V IS PIN 8, -8V IS PIN 4.
- 9. TL072 (8 PIN): +10V IS PIN 8, -8V IS PIN 4.
- 10. POLARITY OF TRANSFORMER AT J2 IS OPTIONAL.
- 11. ALL VALUES SHOWN IN SCHEMATIC ARE FOR US VERSION.

SAFETY CONTROLLED					
	LEVEL	DRAFTER	DATE	 FRAMINGHAM, MA 01701-9168	
	3	CHECKER	8/5/97		
		ENGINEER	8/5/97		
2	SAFETY ENGINEER	8/5/97			
UNLESS OTHERWISE SPECIFIED INTERPRET THIS DRAWING PER ANSI Y14.3M-1987				DESCRIPTION PC BOARD, BOSE WAVE RADIO	
NOTICE BOSE CORP PROPRIETARY RIGHTS ARE INCLUDED HEREIN. THIS INFORMATION MAY NOT BE COPIED, TRANSFERRED OR DISCLOSED EXCEPT AS AUTHORIZED BY BOSE CORP				SIZE D	FSCM 32108
1 REL TO PROD PER AT REV		CLASS SD	DWG NO. 192330	REV 03	SCALE CAT. CODE
				SHEET 1 OF 4	

DISPLAY BOARD

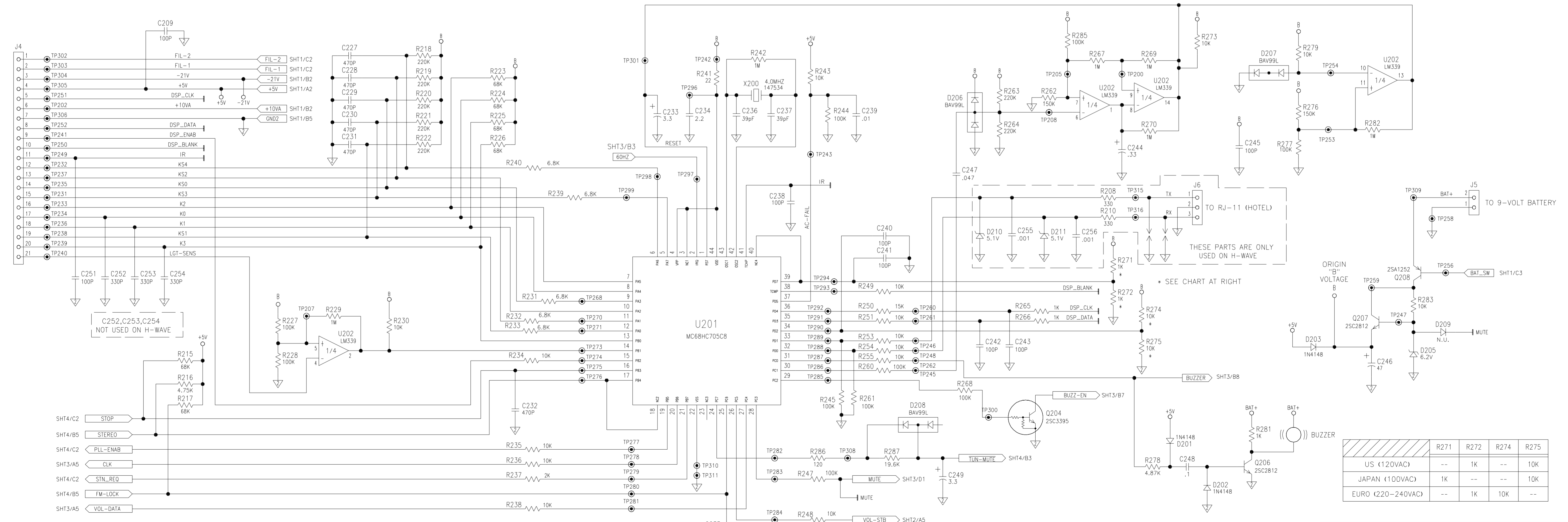
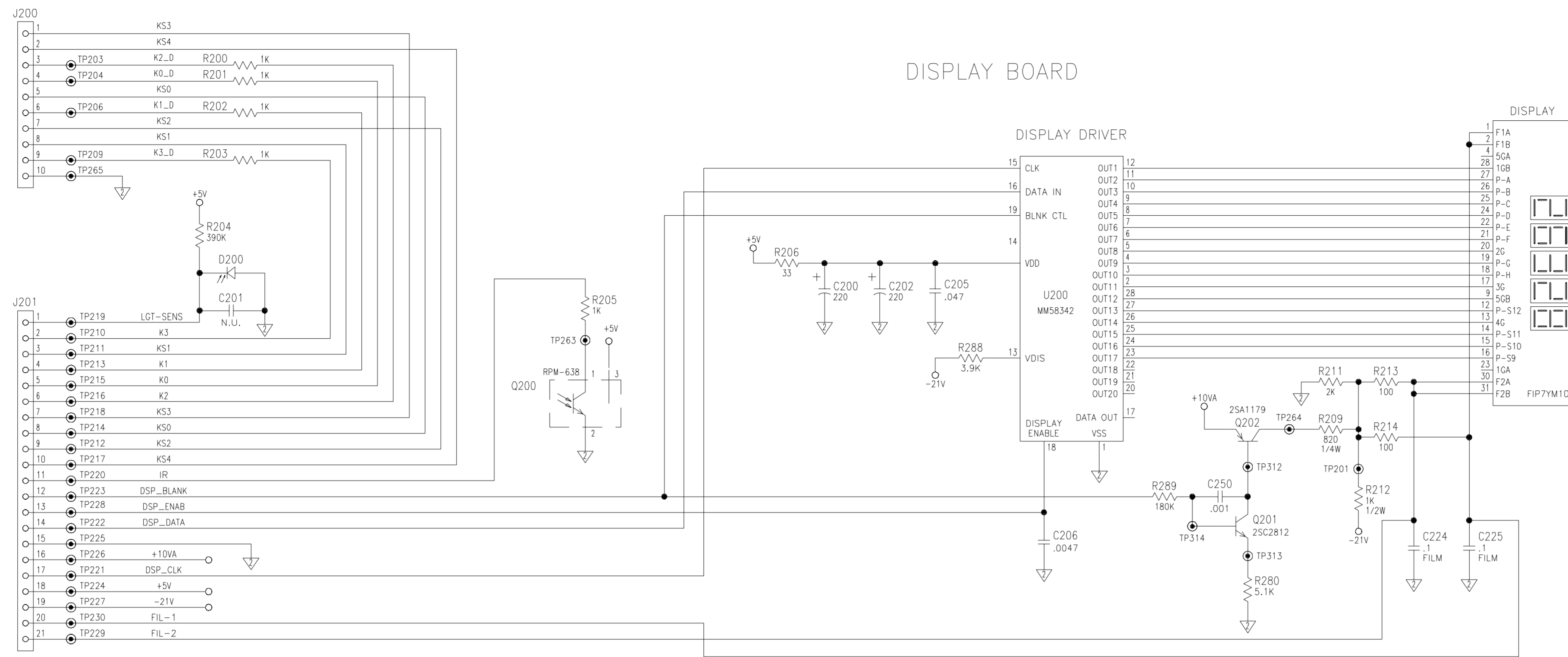

	R271	R272	R274	R275
US (120VAC)	--	1K	--	10K
JAPAN (100VAC)	1K	--	--	10K
EURO (220-240VAC)	--	1K	10K	--

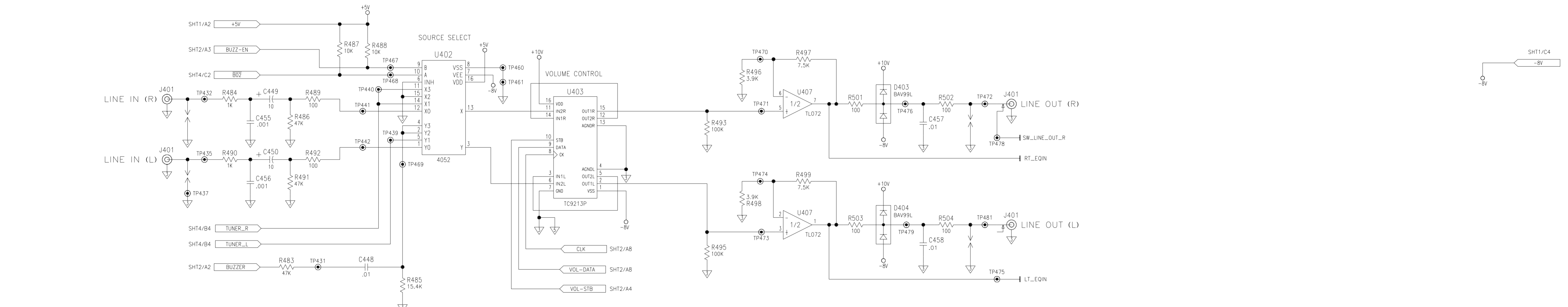
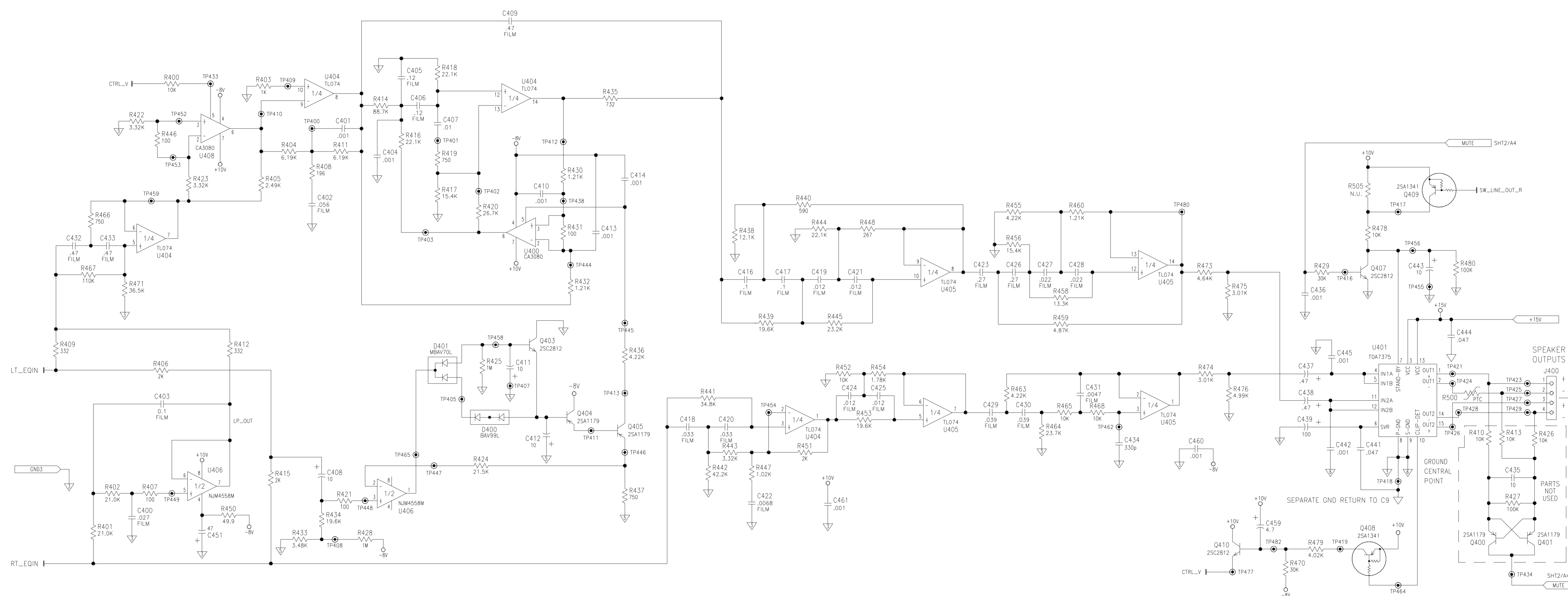

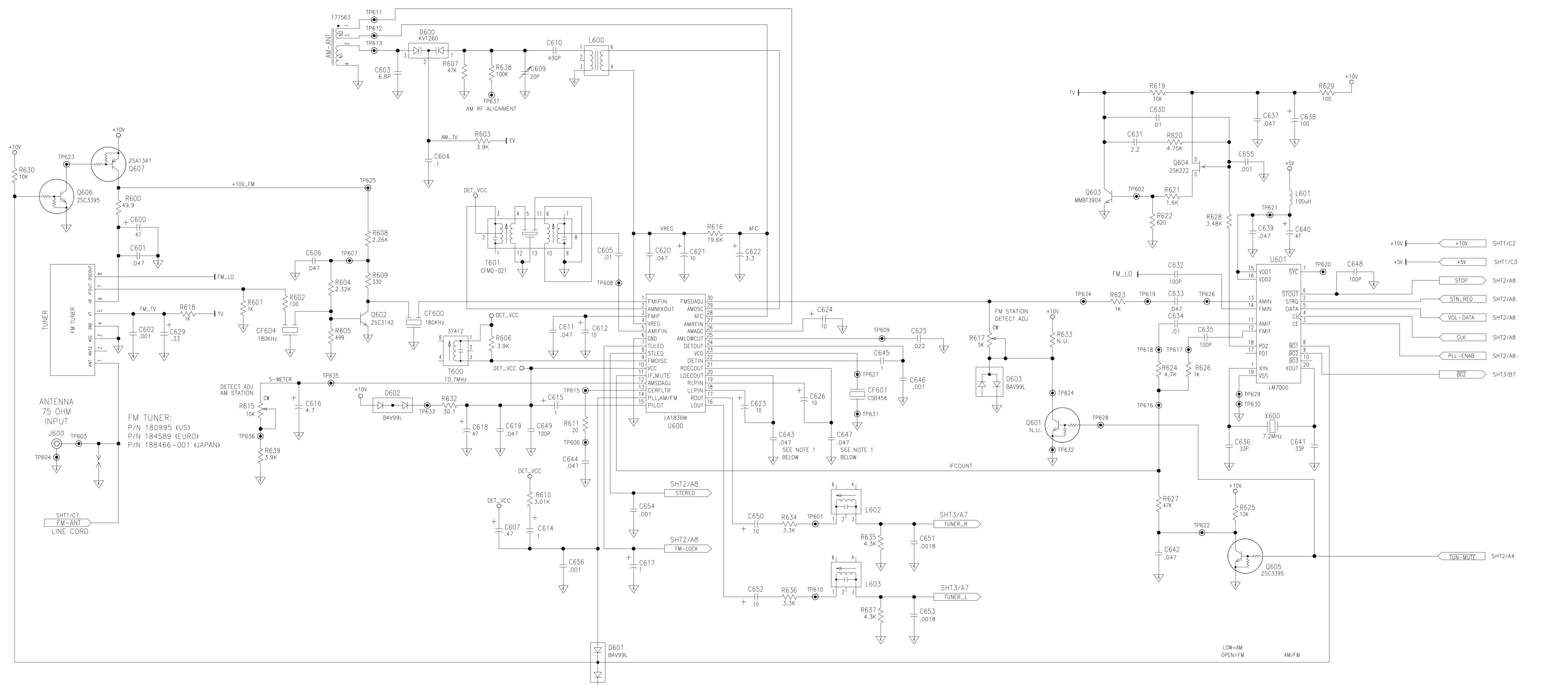

NOTE 1: FOR EUROPE AND JAPAN VERSIONS: C643, C647 = .033uF

CLASS	DWG NO.	SR	REVISIONS				
SD	198160	1	REV	DESCRIPTION	CHK	ENG	DATE
			01	INITIAL RELEASE	--	--	7/14/98
			--	--	--	--	--/--/--

- ⚠ DENOTES CRITICAL COMPONENTS.
REPLACE ONLY WITH IDENTICAL BOSE PARTS.**
- C1: P/N 183627-330 (100VAC/115VAC)
 - R1: P/N 121243-1511065 (100VAC/115VAC)
 - L3,L4: P/N 187598-2R2 (100VAC/115VAC/220VAC-240VAC)
 - BR1: P/N 187611-100 (100VAC/115VAC/220VAC-240VAC)
 - T1: P/N 188465-001 (100VAC)
 - P/N 187595 (115VAC)
 - P/N 188461-001 (220VAC-240VAC)
 - J1: P/N 146563 (100VAC/115VAC)
 - P/N 145306 (220VAC-240VAC)
 - J2: P/N 178742-2 (100VAC/115VAC/220VAC-240VAC)
 - J3: P/N 133220-6 (100VAC/115VAC/220VAC-240VAC)
 - F1: P/N 135677-04 (100VAC/115VAC)
 - P/N 135671-02 (220VAC-240VAC)
- LINE CORD ASSEMBLY:
- P/N 172045 (US)
 - P/N 184599 (EUR)
 - P/N 134725 (UK , SINGAPORE)
 - P/N 134726 (AUS)
 - P/N 145316 (JAPAN)

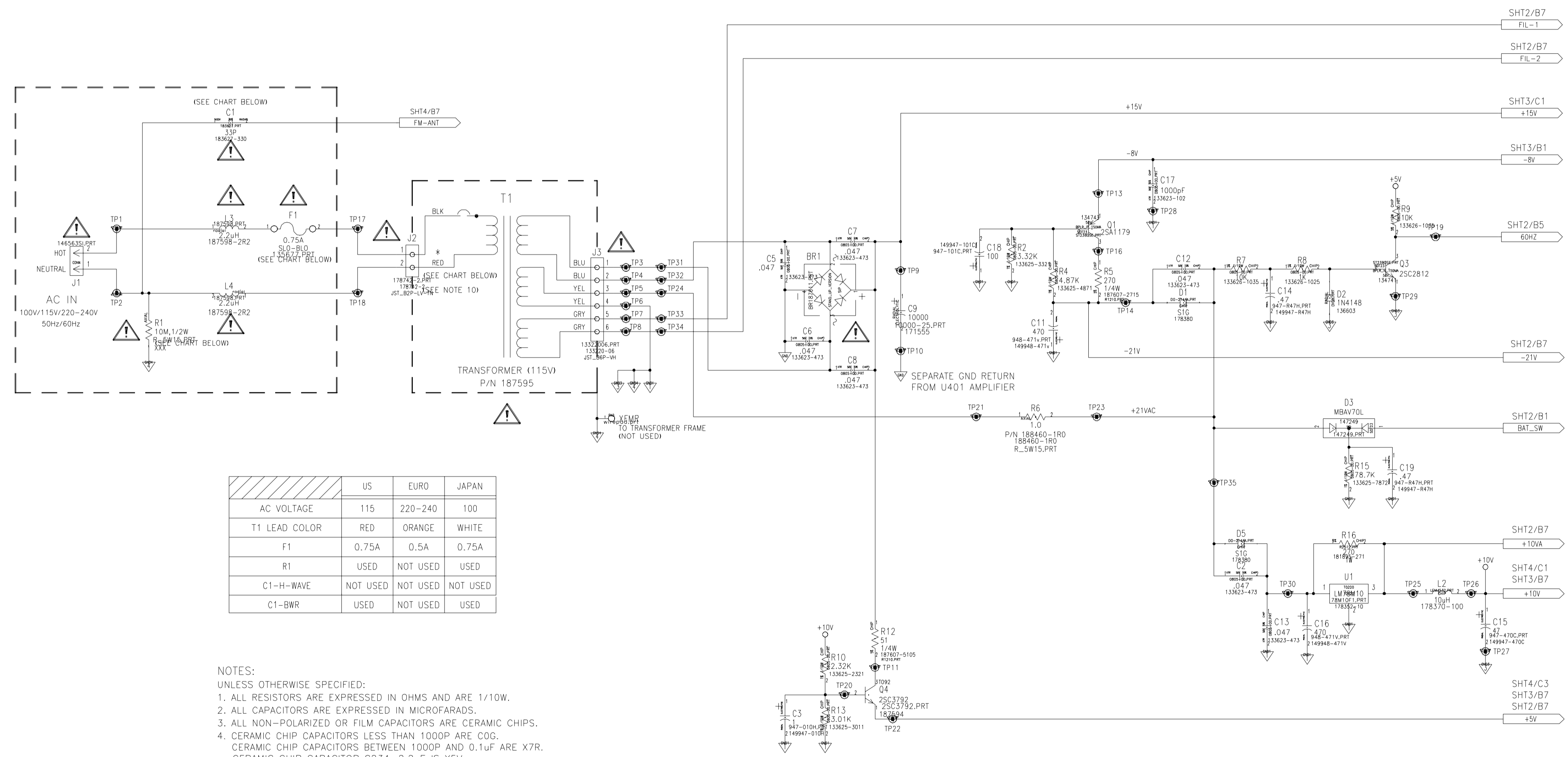

	US	EURO	JAPAN
AC VOLTAGE	115	220-240	100
T1 LEAD COLOR	RED	ORANGE	WHITE
F1	0.75A	0.5A	0.75A
R1	USED	NOT USED	USED
C1-H-WAVE	NOT USED	NOT USED	NOT USED
C1-BWR	USED	NOT USED	USED

- NOTES:
- UNLESS OTHERWISE SPECIFIED:
 - ALL RESISTORS ARE EXPRESSED IN OHMS AND ARE 1/10W.
 - ALL CAPACITORS ARE EXPRESSED IN MICROFARADS.
 - ALL NON-POLARIZED OR FILM CAPACITORS ARE CERAMIC CHIPS.
 - CERAMIC CHIP CAPACITORS LESS THAN 1000P ARE COG. CERAMIC CHIP CAPACITORS BETWEEN 1000P AND 0.1uF ARE X7R. CERAMIC CHIP CAPACITOR C234, 2.2uF IS Y5V.
 - LM393 (8 PIN): +10V IS PIN 8, GND4 IS PIN 4.
 - LM339 (14 PIN): B IS PIN 3, GND2 IS PIN 12.
 - TL074 (14 PIN): +10V IS PIN 4, -8V IS PIN 11.
 - NJM4558M (8 PIN): +10V IS PIN 8, -8V IS PIN 4.
 - TL072 (8 PIN): +10V IS PIN 8, -8V IS PIN 4.
 - POLARITY OF TRANSFORMER AT J2 IS OPTIONAL.
 - ALL VALUES SHOWN IN SCHEMATIC ARE FOR US VERSION.

SAFETY CONTROLLED

THIRD ANGLE PROJECTION 	LEVEL 3	DRAFTER	DATE	BOSE FRAMINGHAM, MA 01701-9168
		CHECKER	7/14/98	
UNLESS OTHERWISE SPECIFIED INTERPRET THIS DRAWING PER ANSI Y14.5M-1982	2	ENGINEER	7/14/98	
		SAFETY ENGINEER	7/14/98	
NOTICE BOSE CORP. PROPRIETARY RIGHTS ARE INCLUDED HEREIN. THIS INFORMATION MAY NOT BE COPIED, TRANSMITTED OR DISCLOSED EXCEPT AS AUTHORIZED BY BOSE CORP.	1	REL TO PROD PER NDI AT REV 00	7/17/98	

DESCRIPTION: PC BOARD, BOSE WAVE RADIO

SIZE	FSCM	CLASS	DWG NO.	REV
D	32108	SD	198160	01
SCALE	CAT. CODE	SHEET 1 OF 4		

DISPLAY BOARD

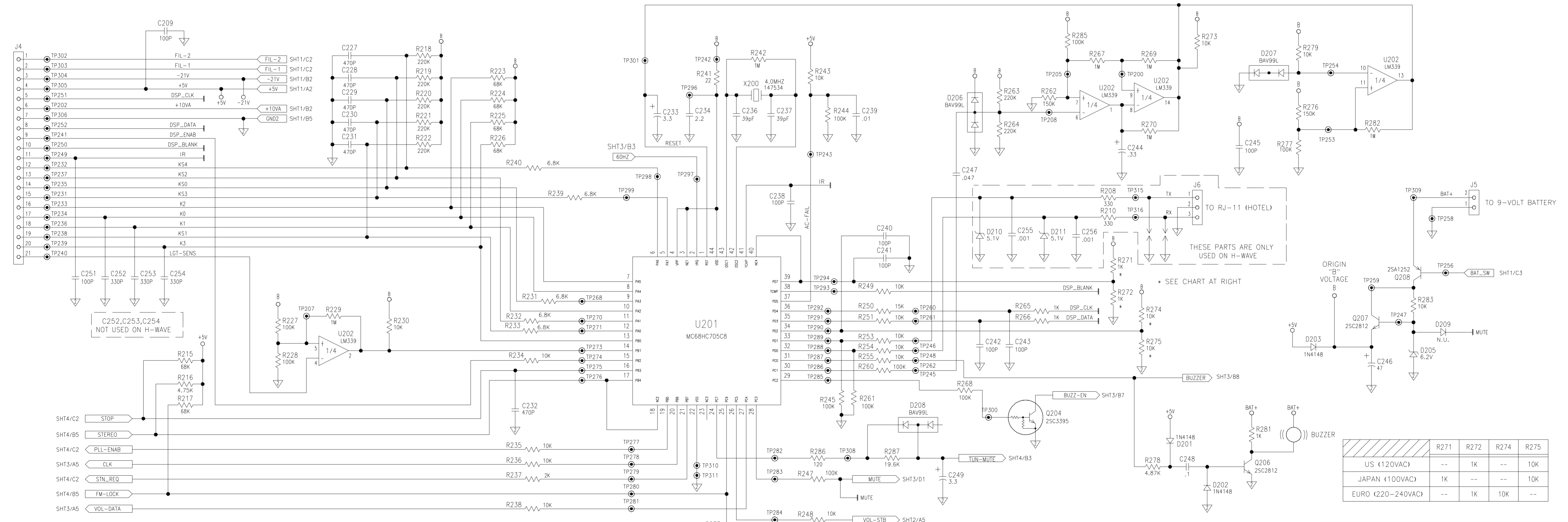
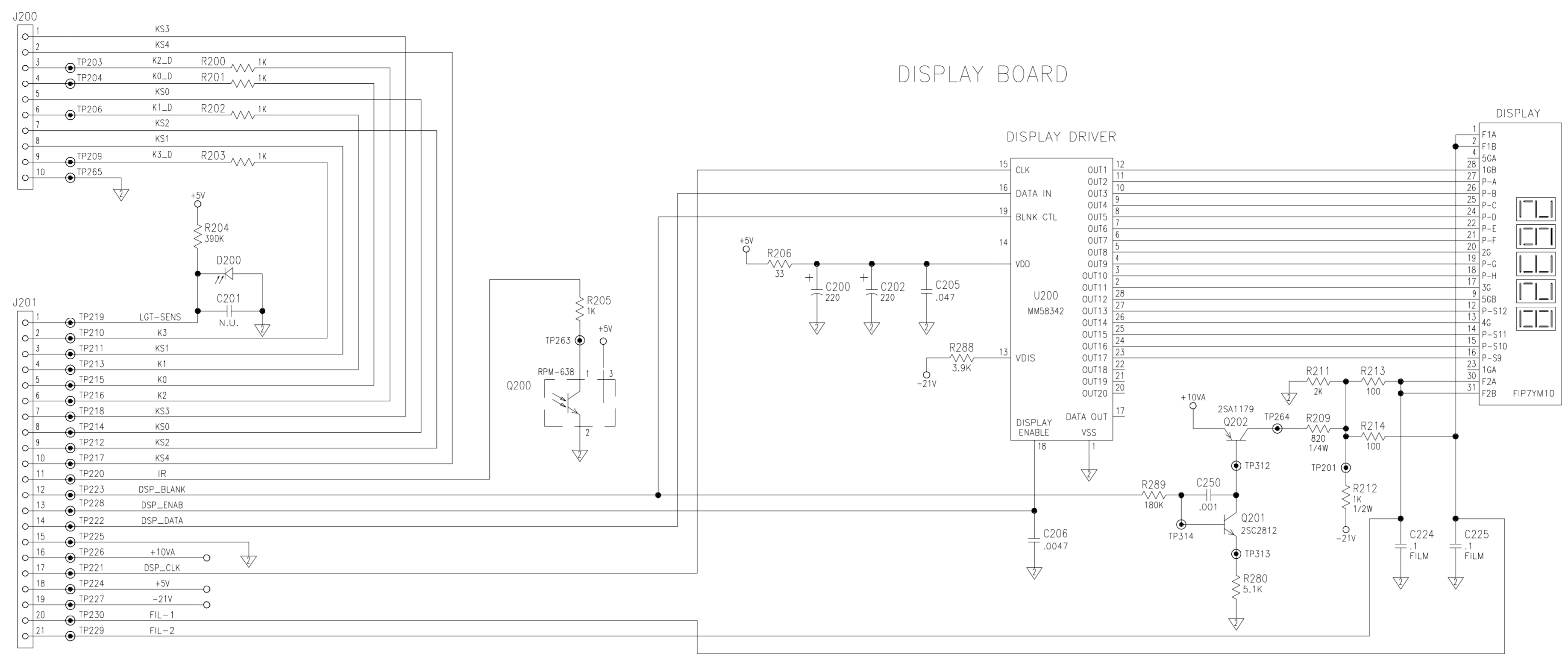

	R271	R272	R274	R275
US (120VAC)	--	1K	--	10K
JAPAN (100VAC)	1K	--	--	10K
EURO (220-240VAC)	--	1K	10K	--

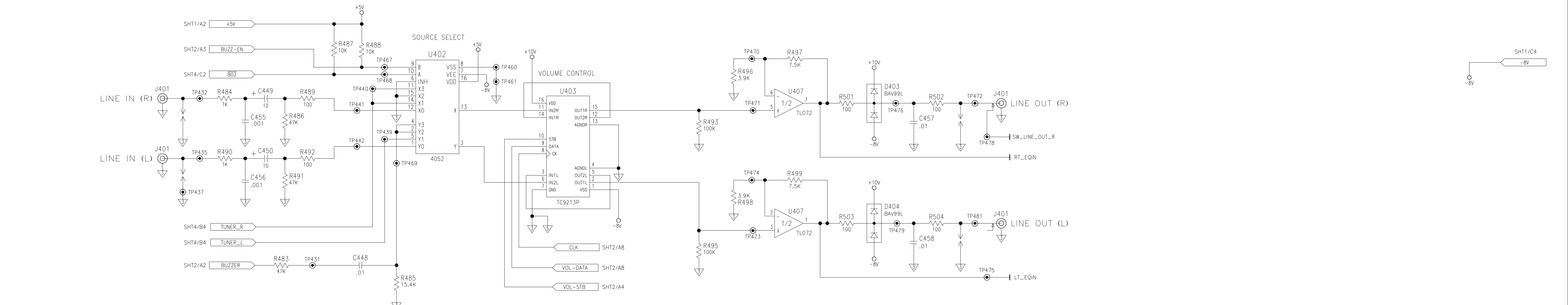
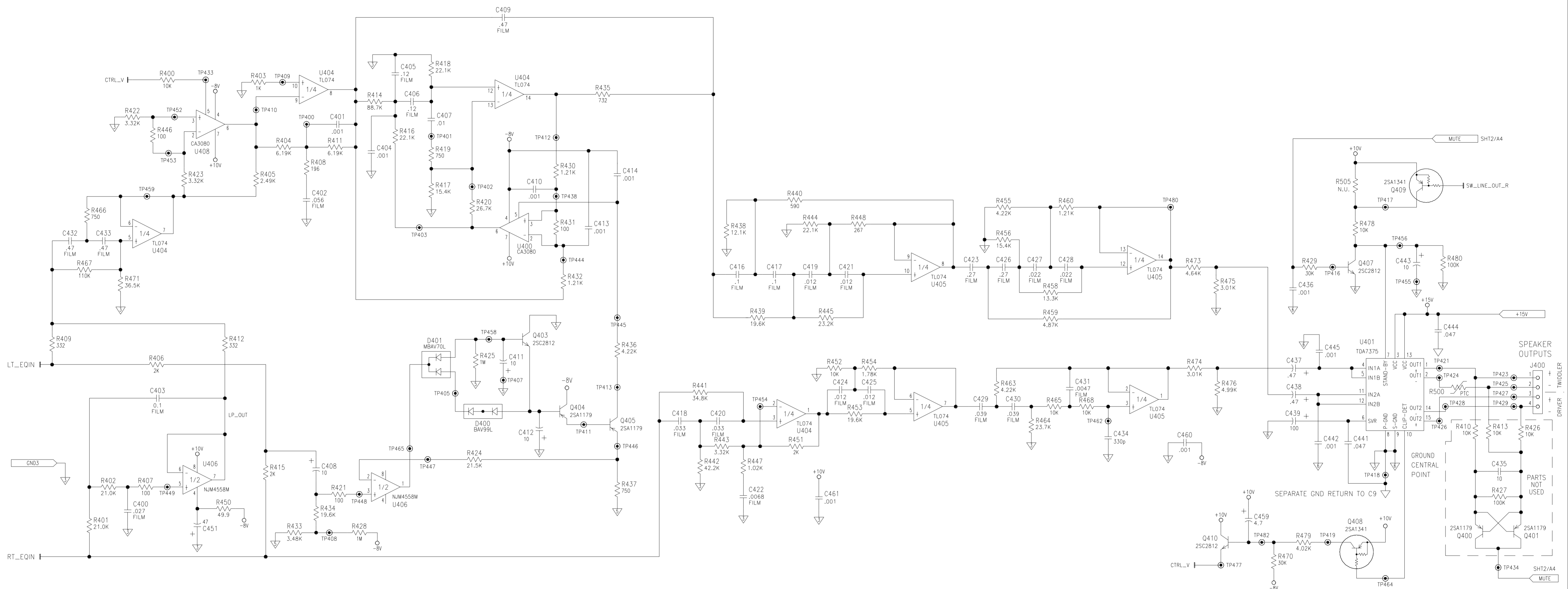

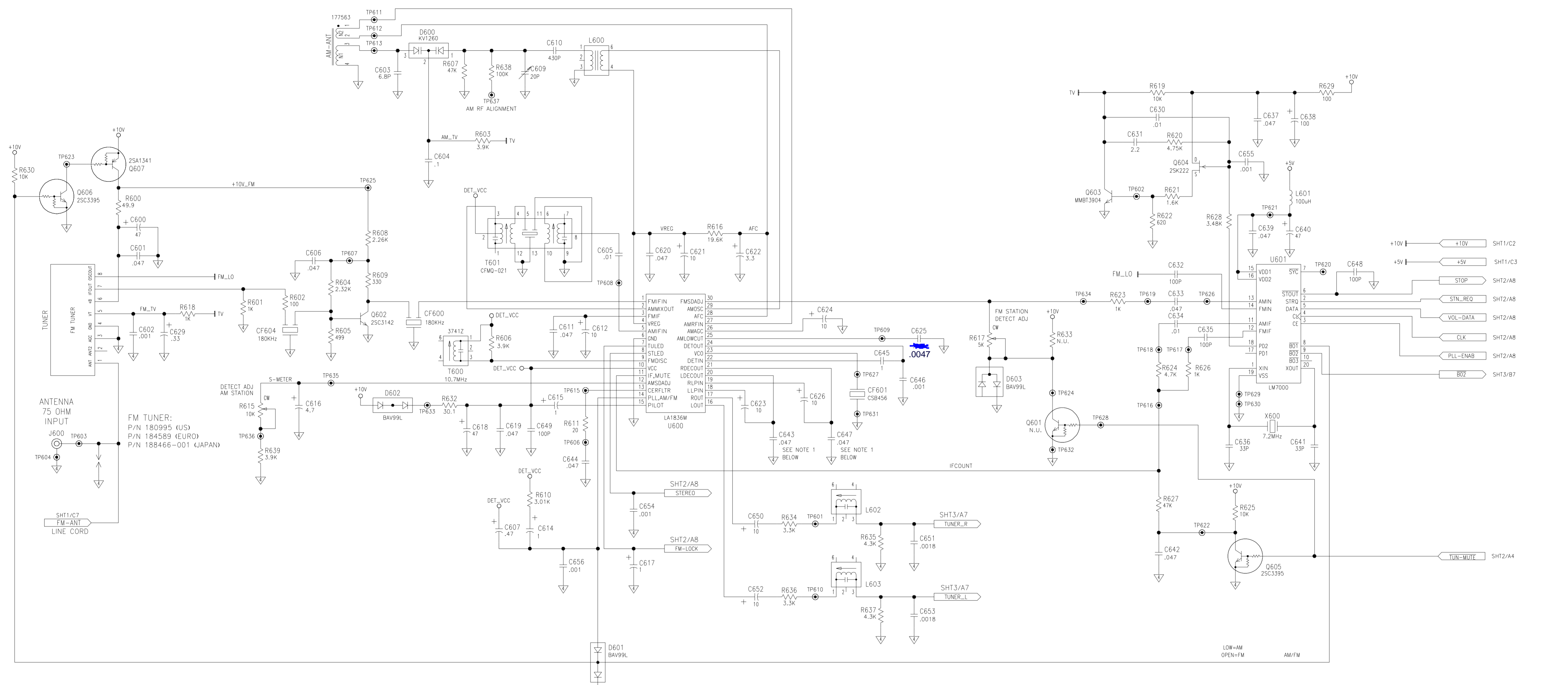

NOTE 1: FOR EUROPE AND JAPAN VERSIONS: C643, C647 = .033uF

⚠ DENOTES CRITICAL COMPONENTS.
 REPLACE ONLY WITH IDENTICAL BOSE PARTS.

- C1: P/N 183627-330 (100VAC/115VAC)
- R1: P/N 121243-1511065 (100VAC/115VAC)
- L3,L4: P/N 187598-2R2 (100VAC/115VAC/220VAC-240VAC)
- BR1: P/N 187611-100 (100VAC/115VAC/220VAC-240VAC)
- T1: P/N 188465-001 (100VAC)
- P/N 187595 (115VAC)
- P/N 188461-001 (220VAC-240VAC)
- J1: P/N 146563 (100VAC/115VAC)
- P/N 145306 (220VAC-240VAC)
- J2: P/N 178742-2 (100VAC/115VAC/220VAC-240VAC)
- J3: P/N 133220-6 (100VAC/115VAC/220VAC-240VAC)
- F1: P/N 135677-04 (100VAC/115VAC)
- P/N 135671-03 (220VAC-240VAC)
- LINE CORD ASSEMBLY: P/N 172045 (US)
- P/N 184599 (EUR)
- P/N 134725 (UK, SINGAPORE)
- P/N 134726 (AUS)
- P/N 145316 (JAPAN)

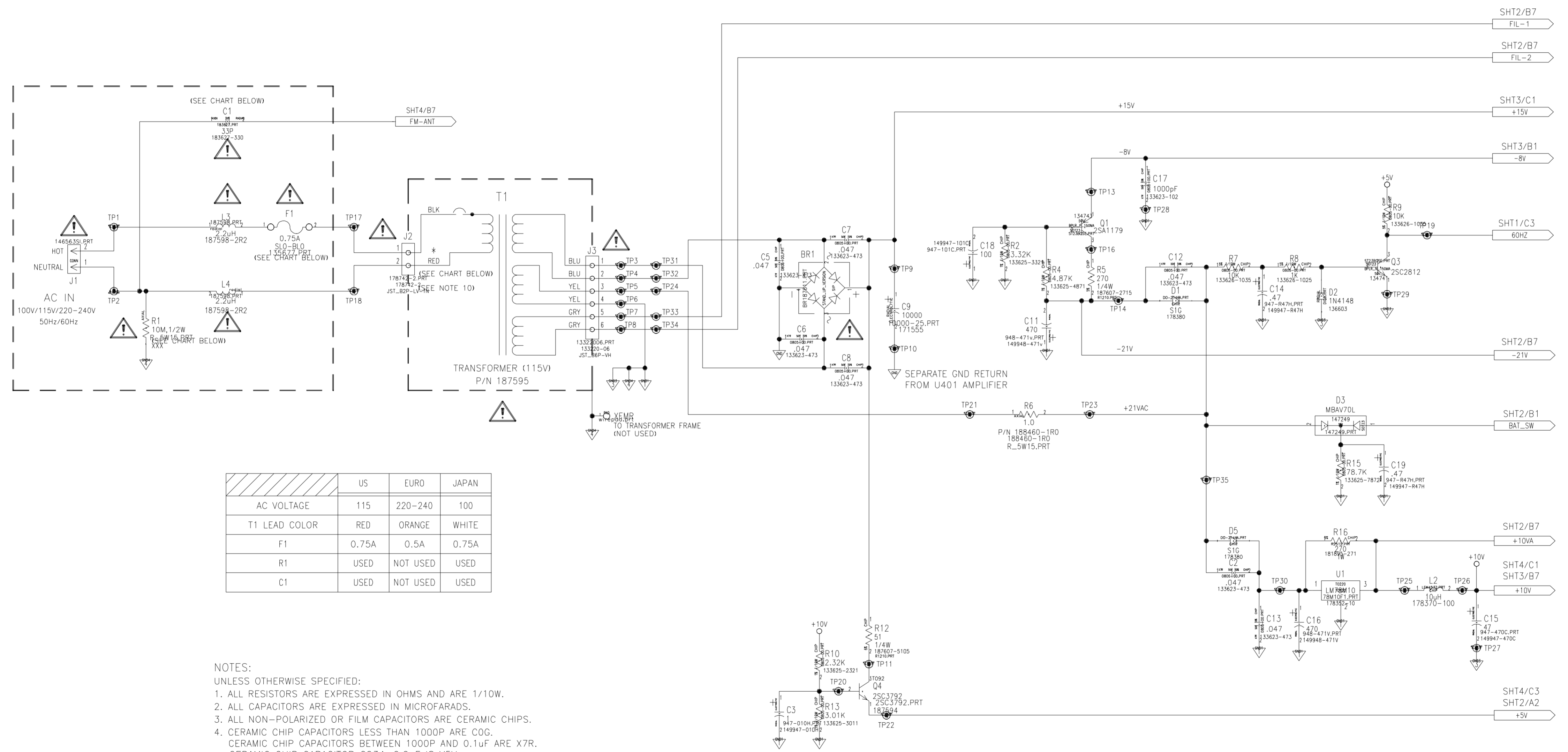

	US	EURO	JAPAN
AC VOLTAGE	115	220-240	100
T1 LEAD COLOR	RED	ORANGE	WHITE
F1	0.75A	0.5A	0.75A
R1	USED	NOT USED	USED
C1	USED	NOT USED	USED

- NOTES:
 UNLESS OTHERWISE SPECIFIED:
 1. ALL RESISTORS ARE EXPRESSED IN OHMS AND ARE 1/10W.
 2. ALL CAPACITORS ARE EXPRESSED IN MICROFARADS.
 3. ALL NON-POLARIZED OR FILM CAPACITORS ARE CERAMIC CHIPS.
 4. CERAMIC CHIP CAPACITORS LESS THAN 1000P ARE COG.
 CERAMIC CHIP CAPACITORS BETWEEN 1000P AND 0.1uF ARE X7R.
 CERAMIC CHIP CAPACITOR C234, 2.2uF IS Y5V.
 5. LM393 (8 PIN): +10V IS PIN 8, GND4 IS PIN 4.
 6. LM339 (14 PIN): B IS PIN 3, GND2 IS PIN 12.
 7. TL074 (14 PIN): +10V IS PIN 4, -8V IS PIN 11.
 8. NJM4558M (8 PIN): +10V IS PIN 8, -8V IS PIN 4.
 9. TL072 (8 PIN): +10V IS PIN 8, -8V IS PIN 4.
 10. POLARITY OF TRANSFORMER AT J2 IS OPTIONAL.
 11. ALL VALUES SHOWN IN SCHEMATIC ARE FOR US VERSION.

SAFETY CONTROLLED

THIRD ANGLE PROJECTION 	LEVEL 3	DRAFTER 12/6/96	FRAMINGHAM, MA 01701-9168
		CHECKER 12/6/96	
		ENGINEER 12/6/96	
UNLESS OTHERWISE SPECIFIED INTERPRET THIS DRAWING PER ANSI Y14.3M-1987	NOTICE BOSE CORP PROPRIETARY RIGHTS ARE INCLUDED HEREIN. THIS INFORMATION MAY NOT BE COPIED, TRANSFERRED OR DISCLOSED EXCEPT AS AUTHORIZED BY BOSE CORP	SAFETY ENGINEER 12/6/96	DESCRIPTION PC BOARD, BOSE WAVE RADIO
		REL TO PROD PER AT REV	SIZE: D FSCM: 32108 CLASS: SD DWG NO.: 187606 REV: 01

SCALE: CAT. CODE SHEET 1 OF 4