

# MDS-JE520

## SERVICE MANUAL



US Model  
Canadian Model  
AEP Model  
UK Model  
E Model  
Australian Model



U.S. and foreign patents licensed from Dolby Laboratories Licensing Corporation.

Model Name Using Similar Mechanism	NEW
MD Mechanism Type	MDM-5A
Optical Pick-up Type	KMS-260A/J1N

### SPECIFICATIONS

Disc	MiniDisc
Laser	Semiconductor laser ( $\lambda = 780 \text{ nm}$ ) Emission duration: continuous
Laser output	Less than $44.6 \mu\text{W}^*$  * This output is the value measured at a distance of 200 mm from the objective lens surface on the Optical Pick-up Block with 7 mm aperture.
Laser diode properties	Material: GaAlAs
Revolutions (CLV)	400 rpm to 900 rpm
Error correction	Advanced Cross Interleave Reed Solomon Code (ACIRC)
Sampling frequency	44.1 kHz
Coding	Adaptive Transform Acoustic Coding (ATRAC)
Modulation system	EFM (Eight-to-Fourteen Modulation)
Number of channels	2 stereo channels
Frequency response	5 to 20,000 Hz $\pm 0.3 \text{ dB}$
Signal-to-noise ratio	Over 96 dB during playback
Wow and flutter	Below measurable limit

#### Inputs

	Jack type	Input impedance	Rated input	Minimum input
LINE (ANALOG) IN	Phono jacks	47 kilohms	500 mVrms	125 mVrms
<b>EXCEPT US, Canadian models</b>				
DIGITAL OPTICAL IN	Square optical connector jack	Optical wave length: 660 nm	—	—

#### EXCEPT US, Canadian models

DIGITAL COAXIAL IN	Phono jack	75 ohms	0.5 V <sub>p-p</sub> , $\pm 20\%$	—
--------------------	------------	---------	-----------------------------------	---

#### US, Canadian models

DIGITAL OPT 1	Square optical connector jack	Optical wave length: 660 nm	—	—
---------------	-------------------------------	-----------------------------	---	---

#### US, Canadian models

DIGITAL OPT 2	Square optical connector jack	Optical wave length: 660 nm	—	—
---------------	-------------------------------	-----------------------------	---	---

#### Outputs

	Jack type	Rated output	Load impedance
PHONES	Stereo phone jack	28 mW	32 ohms
LINE (ANALOG) OUT	Phono jacks	2 Vrms (at 50 kilohms)	Over 10 kilohms
DIGITAL OPTICAL OUT	Square optical connector jack	-18 dBm	Optical wave length: 660 nm

— Continued on next page —

## MINIDISC DECK



# SONY®

## General

### Power requirements

Where purchased	Power requirements
Continental Europe and UK	220 – 230 V AC, 50/60 Hz
Other countries	110 – 120, 220 – 240 V AC, 50/60 Hz
US, Canadian	120 V AC, 60 Hz
Power consumption	18 W
Dimensions (approx.) (w/h/d) incl. projecting parts and controls	430 × 95 × 280 mm
Mass (approx.)	3.4 kg

### Supplied accessories

- Audio connecting cords (2)
- Optical cable (1)
- Remote commander (remote) RM-D15M (1)
- Sony R6 (size-AA) batteries (2)

### Optional accessories

Recordable MDs MDW-60 (60 min), MDW-74 (74 min)

Design and specifications are subject to change without notice.

## SELF-DIAGNOSIS FUNCTION

The self-diagnosis function consists of error codes for customers which are displayed automatically when errors occur, and error codes which show the error history in the test mode during servicing. For details on how to view error codes for the customer, refer to the following box in the instruction manual. For details on how to check error codes during servicing, refer to the following “Procedure for using the Self-Diagnosis Function (Error History Display Mode)”.

### Self-Diagnosis Function

The deck has a self-diagnosis display. This function shows a three-digit display (a combination of a letter and figures) and the corresponding message alternately, so you can check the deck's condition.

If such a display appears, check the following table in order to resolve the problem.

Should any problem persist, consult your nearest Sony dealer.

Self-diagnosis display



Three-digit display/Message	Cause/Remedy
C11/Protected	The inserted MD is record-protected. ➔ Take out the MD, and close the record-protect tab (page 7).
C13/REC Error	The recording was not made properly. ➔ Set the deck in a stable place, and repeat the recording procedure. The inserted MD is dirty (with smudges, fingerprints, etc.), scratched, or not up to standards. ➔ Replace the disc, and repeat the recording procedure.
C13/Disc Error	The deck could not read the TOC of the MD properly. ➔ Take out the MD, and insert it again.
C14/Disc Error	The deck could not read the TOC of the MD properly. ➔ Insert another disc. ➔ If possible, erase all tracks on the MD using the All Erase Function on page 29.
C71/13in Unlock	A moment's lighting is due to the signals of the digital program being recorded. This does not affect the recorded material. While recording from a digital component connected through the digital input connector, the digital connecting cable was unplugged or the digital component turned off. ➔ Connect the cable or turn the digital component back on.

### Procedure for using the Self-Diagnosis Function (Error History Display Mode).

**Note:** Perform the self-diagnosis function in the “error history display mode” in the test mode. The following describes the least required procedure. Be careful not to enter other modes by mistake. If you set other modes accidentally, press the **[MENU/NO]** button to exit the mode.

1. While pressing the **[AMS]** knob and **[■]** button, connect the power plug to the outlet, and release the **[AMS]** knob and **[■]** button.
2. Rotate the **[AMS]** knob and when “[Service]” is displayed, press the **[YES]** button.
3. Rotate the **[AMS]** knob and display “ERR DP MODE”.
4. Pressing the **[YES]** button sets the error history mode and displays “total rec”.
5. Select the contents to be displayed or executed using the **[AMS]** knob.
6. Pressing the **[AMS]** knob will display or execute the contents selected.
7. Pressing the **[AMS]** knob another time returns to step 4.
8. Pressing the **[MENU/NO]** button displays “ERROR DP MODE” and exits the error history mode.
9. To exit the test mode, press the **[REPEAT]** button. The unit sets into the STANDBY state, the disc is ejected, and the test mode ends.

## ITEMS OF ERROR HISTORY MODE ITEMS AND CONTENTS

### Selecting the Test Mode

Display	Details of History
total rec	Displays the recording time. Displayed as "r□□□□□h". The displayed time is the total time the laser is set to the high power state. This is about 1/4 of the actual recording time. The time is displayed in decimal digits from 0h to 65535h.
total play	Displays the play time. Displayed as "p□□□□□h". The time displayed is the total actual play time. Pauses are not counted. The time is displayed in decimal digits from 0h to 65535h.
retry err	Displays the total number of retries during recording and number of retry errors during play. Displayed as "r□□ p□□". "r" indicates the retries during recording while "p" indicates the retry errors during play. The number of retries and retry errors are displayed in hexadecimal digits from 00 to FF.
total err	Displays the total number of errors. Displayed as "total □□". The number of errors is displayed in hexadecimal digits from 00 to FF.
err history	Displays the 10 latest errors. Displayed as "0□ E@@". □ indicates the history number. The smaller the number, the more recent is the error. (00 is the latest). @@ indicates the error code. Refer to the following table for the details. The error history can be switched by rotating the <b>[AMS]</b> knob.
er refresh	Mode which erases the "retry err", "total err", and "err history" histories. When returning the unit to the customer after completing repairs, perform this to erase the past error history. After pressing the <b>[AMS]</b> button and "er refresh?" is displayed, press the <b>[YES]</b> button to erase the history. "Complete!" will be displayed momentarily. Be sure to check the following when this mode has been executed. <ul style="list-style-type: none"> <li>• The data has been erased.</li> <li>• The mechanism operates normally when recording and play are performed.</li> </ul>
tm refresh	Mode which erases the "total rec" and "total play" histories. These histories serve as approximate indications of when to replace the optical pickup. If the optical pickup has been replaced, perform this operation and erase the history. After pressing the <b>[AMS]</b> button and "tm refresh?" is displayed, press the <b>[YES]</b> button to erase the history. "Complete!" will be displayed momentarily. Be sure to check the following when this mode has been executed. <ul style="list-style-type: none"> <li>• The data has been erased.</li> <li>• The mechanism operates normally when recording and play are performed.</li> </ul>

**Table of Error Codes**

Error Code	Details of Error	Error Code	Details of Error
E00	No error	E05	FOK has deviated
E01	Disc error. PTOC cannot be read (DISC ejected)	E06	Cannot focus (Servo has deviated)
		E07	Recording retry
E02	Disc error. UTOC error (DISC not ejected)	E08	Recording retry error
		E09	Playback retry error (Access error)
E03	Loading error		
E04	Address cannot be read (Servo has deviated)	E0A	Play retry error (C2 error)

## CAUTION

Danger of explosion if battery is incorrectly replaced.  
Replace only with the same or equivalent type recommended by the equipment manufacturer.  
Discard used batteries according to manufacturer's instructions.

## ADVARSEL!

Lithiumbatteri - Eksplosionsfare ved fejlagtig håndtering.  
Udskiftning må kun ske med batteri af samme fabrikat og type.  
Levér det brugte batteri tilbage til leverandøren.

## ADVARSEL

Eksplosjonsfare ved feilaktig skifte av batteri.  
Benytt samme batteritype eller en tilsvarende type anbefalt av apparatfabrikanten.  
Brukte batterier katterier kasseres i henhold til fabrikantens

## VARNIG

Explosionsfara vid felaktigt batteribyte.  
Använd samma batterityp eller en likvärdig typ som rekommenderas av apparattillverkaren.  
Kassera använt batteri enligt gällande föreskrifter.

## VAROITUS

Parist voi räjähtää, jos se on virheellisesti asennettu.  
Vaihda paristo ainoastaan laitevalmistajan suosittelemaan tyyppiin.  
Hävitätä käytetty paristo valmistajan ohjeiden mukaisesti.

Laser component in this product is capable of emitting radiation exceeding the limit for Class 1.

CLASS 1 LASER PRODUCT  
LUOKAN 1 LASERLAITE  
KLASS 1 LASERAPPARAT

This appliance is classified as a CLASS 1 LASER product. The CLASS 1 LASER PRODUCT MARKING is located on the rear exterior.

CAUTION	;	INVISIBLE LASER RADIATION WHEN OPEN. AVOID EXPOSURE TO BEAM.
ADVARSEL	;	USYNLIG LASERSTRÅLING VED ÅBNING NÅR SIKKERHEDSAFBRYDERE ER UDE AF FUNKTION. UNDGÅ UDSÆTTELSE FOR STRÅLING.
VARO!	;	AVATTAESSA JA SUOJALUKITUS OHITETTAESSA DLET ALTTIINA LASERSÄTELYLLE.
VARNING	;	LASERSTRÅLING NÅR DENNA DEL ÅR OPPNÅD OCH SPÅRREN ÅR URKOPPLAD.
ADVARSEL	;	USYNLIG LASERSTRÅLING NÅR DEKSEL ÅPNES UNNGÅ EKSPONERING FOR STRÅLEN.

This caution label is located inside the unit.

## CAUTION

Use of controls or adjustments or performance of procedures other than those specified herein may result in hazardous radiation exposure.

## Notes on chip component replacement

- Never reuse a disconnected chip component.
- Notice that the minus side of a tantalum capacitor may be damaged by heat.

## Flexible Circuit Board Repairing

- Keep the temperature of soldering iron around 270°C during repairing.
- Do not touch the soldering iron on the same conductor of the circuit board (within 3 times).
- Be careful not to apply force on the conductor when soldering or unsoldering.

## SAFETY-RELATED COMPONENT WARNING !!

COMPONENTS IDENTIFIED BY MARK  $\triangle$  OR DOTTED LINE WITH MARK  $\triangle$  ON THE SCHEMATIC DIAGRAMS AND IN THE PARTS LIST ARE CRITICAL TO SAFE OPERATION. REPLACE THESE COMPONENTS WITH SONY PARTS WHOSE PART NUMBERS APPEAR AS SHOWN IN THIS MANUAL OR IN SUPPLEMENTS PUBLISHED BY SONY.

## ATTENTION AU COMPOSANT AYANT RAPPORT À LA SÉCURITÉ!!

LES COMPOSANTS IDENTIFIÉS PAR UNE MARQUE  $\triangle$  SUR LES DIAGRAMMES SCHÉMATIQUES ET LA LISTE DES PIÈCES SONT CRITIQUES POUR LA SÉCURITÉ DE FONCTIONNEMENT. NE REMPLACER CES COMPOSANTS QUE PAR DES PIÈCES SONY DONT LES NUMÉROS SONT DONNÉS DANS CE MANUEL OU DANS LES SUPPLÉMENTS PUBLIÉS PAR SONY.

## SAFETY CHECK-OUT

After correcting the original service problem, perform the following safety checks before releasing the set to the customer:  
Check the antenna terminals, metal trim, “metallized” knobs, screws, and all other exposed metal parts for AC leakage. Check leakage as described below.

### LEAKAGE

The AC leakage from any exposed metal part to earth Ground and from all exposed metal parts to any exposed metal part having a return to chassis, must not exceed 0.5 mA (500 microamperes). Leakage current can be measured by any one of three methods.

1. A commercial leakage tester, such as the Simpson 229 or RCA WT-540A. Follow the manufacturers’ instructions to use these instruments.
2. A battery-operated AC milliammeter. The Data Precision 245 digital multimeter is suitable for this job.
3. Measuring the voltage drop across a resistor by means of a VOM or battery-operated AC voltmeter. The “limit” indication is 0.75 V, so analog meters must have an accurate low-voltage scale. The Simpson 250 and Sanwa SH-63Trd are examples of a passive VOM that is suitable. Nearly all battery operated digital multimeters that have a 2V AC range are suitable. (See Fig. A)

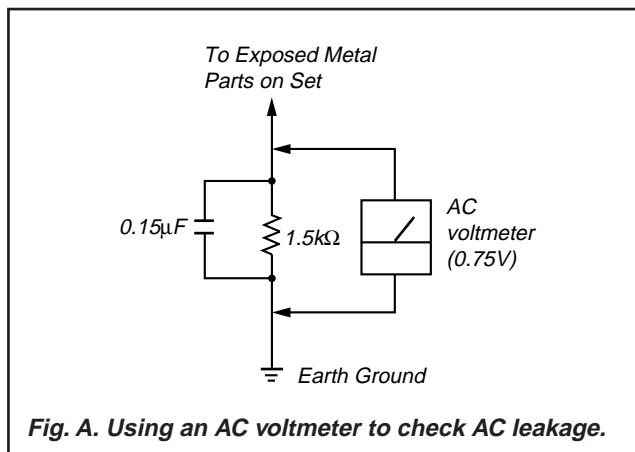

### MODEL IDENTIFICATION — BACK PANEL —

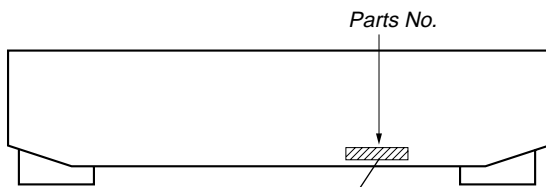

- 4-996-697-3□ US model
- 4-996-697-4□ Canadian model
- 4-998-210-0□ AEP model
- 4-998-210-1□ UK model
- 4-998-210-5□ Australian model
- 4-998-210-6□ E, Singapore model
- 4-998-210-7□ Hong Kong model

## TABLE OF CONTENTS

<b>1. SERVICING NOTE</b> .....	6
<b>2. GENERAL</b> .....	11
<b>3. DISASSEMBLY</b>	
3-1. Case and Front Panel .....	28
3-2. Slider (Cam) .....	28
3-3. Base Unit (MBU-5A) and BD Board .....	29
3-4. SW Board and Loading Motor (M103) .....	29
<b>4. TEST MODE</b> .....	30
<b>5. ELECTRICAL ADJUSTMENTS</b> .....	35
<b>6. DIAGRAMS</b>	
6-1. Circuit Boards Location .....	44
6-2. Brock Diagrams	
• BD Section .....	45
• Main Section .....	47
6-3. Printed Wiring Board – BD Section – .....	51
6-4. Schematic Diagram – BD Section – (1/2) .....	53
Schematic Diagram – BD Section – (2/2) .....	55
6-5. Schematic Diagram – Main Section – (1/2) .....	57
Schematic Diagram – Main Section – (2/2) .....	59
6-6. Printed Wiring Board – Main Section – .....	61
6-7. Printed Wiring Board – Panel Section – .....	63
6-8. Schematic Diagram – Panel Section – .....	65
6-9. Schematic Diagram – BD Switch Section – .....	67
6-10. Printed Wiring Board – BD Switch Section – .....	67
6-11. IC Block Diagrams .....	68
6-12. IC Pin Functions .....	72
<b>7. EXPLODED VIEWS</b>	
7-1. Case and Back Panel Section .....	80
7-2. Front Panel Section .....	81
7-3. Mechanism Section (MDM-5A) .....	82
7-4. Base Unit Section (MBU-5A) .....	83
<b>8. ELECTRICAL PARTS LIST</b> .....	84

# SECTION 1

## SERVICING NOTE

### JIG FOR CHECKING BD BOARD WAVEFORM

The special jig (J-2501-149-A) is useful for checking the waveform of the BD board. The names of terminals and the checking items to be performed are shown as follows.

- GND : Ground
- I+3V : For measuring IOP (Check the deterioration of the optical pick-up laser)
- IOP : For measuring IOP (Check the deterioration of the optical pick-up laser)
- TE : TRK error signal (Traverse adjustment)
- VC : Reference level for checking the signal
- RF : RF signal (Check jitter)

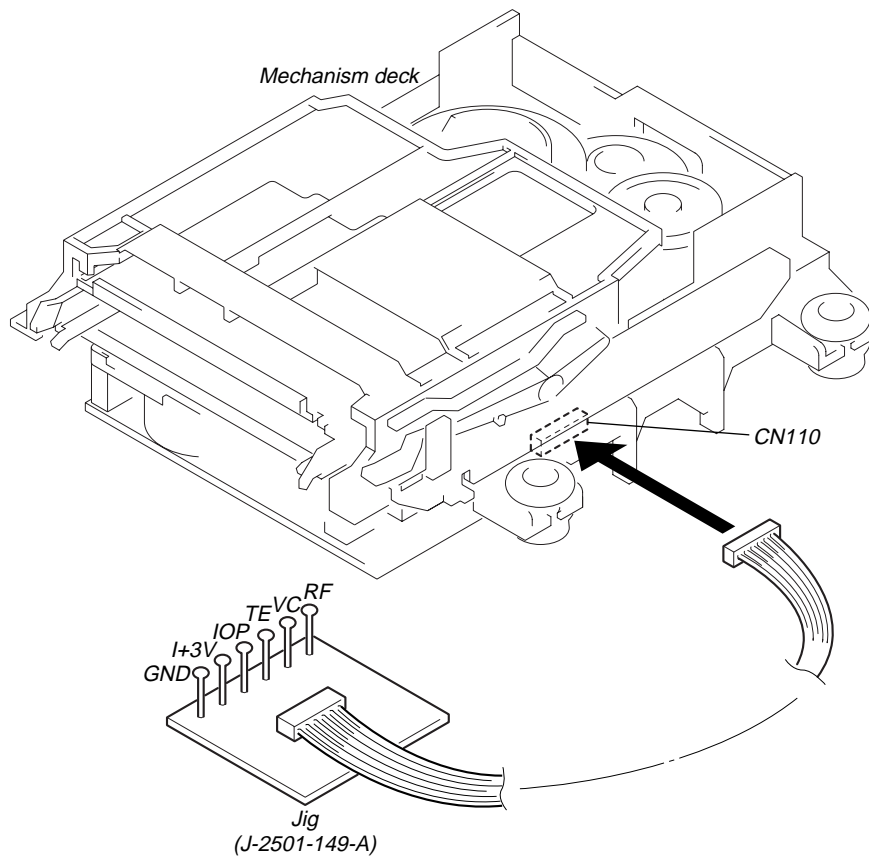

## LASER POWER METER

When performing laser power checks and adjustment (electrical adjustment), use of the new MD laser power meter 8010S (J-2501-145-A) instead of the conventional laser power meter is convenient.

It sharply reduces the time and trouble to set the laser power meter sensor onto the objective lens of the pick-up.



*External View of MD Laser Power Meter 8010S*

### IOP DATA RECORDING AND DISPLAY WHEN PICKUP AND NON-VOLATILE MEMORY (IC171 OF BD BOARD) ARE REPLACED

The IOP value labeled on the pick-up can be recorded in the non-volatile memory. By recording the value, it will eliminate the need to look at the value on the label of the optical pick-up. When replacing the pick-up or non-volatile memory (IC171 of BD board), record the IOP value on the pick-up according to the following procedure.

#### **Record Procedure:**

1. While pressing the [AMS] knob and [■] button, connect the power plug to the outlet, and release the [AMS] knob and [■] button.
2. Rotate the [AMS] knob to display “[Service]”, and press the [YES] button.
3. Rotate the [AMS] knob to display “Iop.Write” (C28), and press the [YES] button.
4. The display becomes “Ref=@ @ . @” (@ is an arbitrary number) and the numbers which can be changed will blink.
5. Input the IOP value written on the optical pick-up.  
To select the number : Rotate the [AMS] knob.  
To select the digit : Press the [AMS] knob.
6. When the [YES] button is pressed, the display becomes “Measu=@ @ @ . @” (@ is an arbitrary number).
7. As the adjustment results are recorded for the 6 value. Leave it as it is and press the [YES] button.
8. “Complete!” will be displayed momentarily. The value will be recorded in the non-volatile memory and the display will become “Iop Write”.
9. Press the [REPEAT] button to complete. “Standby” will be displayed.

#### **Display Procedure:**

1. While pressing the [AMS] knob and [■] button, connect the power plug to the outlet, and release the [AMS] knob and [■] button.
2. Rotate the [AMS] knob to display “[Service]”, and press the [YES] button.
3. Rotate the [AMS] knob to display “Iop.Read” (C27).
4. “@ @ . @ / ## . #” is displayed and the recorded contents are displayed.  
@ @ . @ : indicates the Iop value labeled on the pick-up.  
## . # : indicates the Iop value after adjustment
5. To end, press the [AMS] button or [MENU/NO] button to display “Iop Read”. Then press the [REPEAT] button to display “Standby”.

## CHECKS PRIOR TO PARTS REPLACEMENT AND ADJUSTMENTS

Before performing repairs, perform the following checks to determine the faulty locations up to a certain extent. Details of the procedures are described in "5 Electrical Adjustments".

	Criteria for Determination (Unsatisfactory if specified value is not satisfied)	Measure if unsatisfactory:
Laser power check (5-6-2 : See page 37)	<ul style="list-style-type: none"> <li>0.9 mW power Specified value : 0.84 to 0.92 mW</li> <li>7.0 mW power Specified value : 6.8 to 7.2 mW</li> </ul>	<ul style="list-style-type: none"> <li>Clean the optical pick-up</li> <li>Adjust again</li> <li>Replace the optical pick-up</li> </ul>
	<ul style="list-style-type: none"> <li>Iop (at 7mW)</li> <li>Labeled on the optical pickup</li> <li>Iop value <math>\pm</math> 10mA</li> </ul>	<ul style="list-style-type: none"> <li>Replace the optical pick-up</li> </ul>
Traverse check (5-6-3 : See page 37)	<ul style="list-style-type: none"> <li>Traverse waveform Specified value : Below 10% offset</li> </ul>	<ul style="list-style-type: none"> <li>Replace the optical pick-up</li> </ul>
Focus bias check (5-6-4 : See page 38)	<ul style="list-style-type: none"> <li>Error rate check Specified value : For points a, b, and c C1 error : Below 220 AD error : Below 2</li> </ul>	<ul style="list-style-type: none"> <li>Replace the optical pick-up</li> </ul>
C PLAY check (5-6-5 : See page 38)	<ul style="list-style-type: none"> <li>Error rate check Specified value: a. When using test disc (MDW-74/AU-1) C1 error : Below 80 AD error : Below 2 b. When using check disc (TDYS-1) C1 error : Below 50</li> </ul>	<ul style="list-style-type: none"> <li>Replace the optical pick-up</li> </ul>
Self-recording/playback check (REC/PLAY) (5-6-6 : See page 38)	<ul style="list-style-type: none"> <li>CPLAY error rate check Specified value: C1 error : Below 80 AD error : Below 2</li> </ul>	If always unsatisfactory: <ul style="list-style-type: none"> <li>Replace the overwrite head</li> <li>Check for disconnection of the circuits around the overwrite head</li> </ul>
		If occasionally unsatisfactory: <ul style="list-style-type: none"> <li>Check if the overwrite head is distorted</li> <li>Check the mechanism around the sled</li> </ul>
TEMP check (Temperature compensation offset check) (5-6-1 : See page 37)	<ul style="list-style-type: none"> <li>Unsatisfactory if displayed as T=@@ (##) [NG" NG (@@, ## are both arbitrary numbers)</li> </ul>	<ul style="list-style-type: none"> <li>Check for disconnection of the circuits around D101 (BD board)</li> <li>Check the signals around IC101, IC121, CN102, CN103 (BD board)</li> </ul>

### Note:

The criteria for determination above is intended merely to determine if satisfactory or not, and does not serve as the specified value for adjustments.

When performing adjustments, use the specified values for adjustments.

## FORCED RESET

The system microprocessor can be reset in the following procedure.

Use these procedure when the unit cannot be operated normally due to the overrunning of the microprocessor, etc.

### Procedure :

Disconnect the power plug, short-circuit jumper wire of JW800 and R451 (RESET).

### [MAIN BOARD] (Component Side)

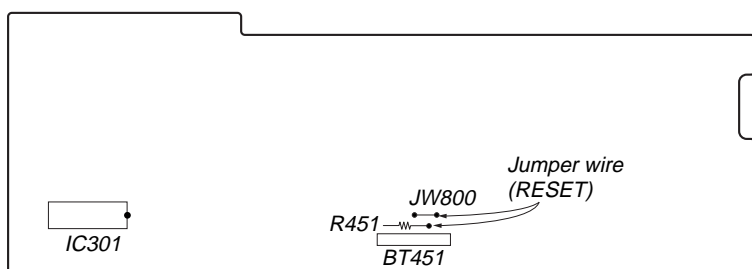



## RETRY CAUSE DISPLAY MODE

- In this test mode, the causes for retry of the unit during recording can be displayed on the fluorescent indicator tube. During playback, the “track mode” for obtaining track information will be set. This is useful for locating the faulty part of the unit.
- The following will be displayed :  
 During recording and stop : Retry cause, number of retries, and number of retry errors.  
 During playback : Information such as type of disc played, part played, copyright.  
 These are displayed in hexadecimal.

### Precedure:

- Load a recordable disc whose contents can be erased into the unit.
- Press the **MENU/NO** button. When “Edit/Menu” is displayed on the fluorescent display tube, rotate the **AMS** knob to display “All Erase?”.
- Press the **YES** button. (Or press the **AMS** knob)
- When “All Erase??” is displayed on the fluorescent display tube, the music calendar number blinks.
- Press the **YES** button to display “Complete!!”, and press the **■** button immediately. Wait for about 15 seconds while pressing the button. (The **AMS** knob can be pressed instead of the **YES** button for the same results.)
- When the “TOC” displayed on the fluorescent display tube goes off, release the **■** button.
- Press the **● REC** button to start recording. Then press the **||** button and start recording.
- To check the “track mode”, press the **▷** button to start play.
- To exit the test mode, press the **I/O** button, and turn OFF the power. When “TOC” disappears, disconnect the power plug from the outlet. If the test mode cannot be exited, refer to “Forced Reset” on page 8.

**Fig. 1 Reading the Test Mode Display (During recording and stop)**

**RTs@@c##c\*\***  
 Fluorescent display tube display

@@ : Cause of retry  
 ## : Number of retries  
 \*\* : Number of retry errors

**Fig. 2 Reading the Test Mode Display (During playback)**

**@@#####\*\*\$\$**  
 Fluorescent display tube display

@@ : Parts No. (name of area named on TOC)  
 ## : Cluster } Address (Physical address on disc)  
 \*\* : Sector }  
 \$\$ : Track mode (Track information such as copyright information of each part)

### Reading the Retry Cause Display

Hexadecimal	Higher Bits				Lower Bits				Hexadecimal	Cause of Retry	Occurring conditions
	8	4	2	1	8	4	2	1			
Bit	b7	b6	b5	b4	b3	b2	b1	b0			
Binary	0	0	0	0	0	0	0	1	01	shock	When track jump (shock) is detected
	0	0	0	0	0	0	1	0	02	ader5	When ADER was counted more than five times continuously
	0	0	0	0	0	1	0	0	04	Discontinuous address	When ADIP address is not continuous
	0	0	0	0	1	0	0	0	08	DIN unlock	When DIN unlock is detected
	0	0	0	1	0	0	0	0	10	FCS incorrect	When not in focus
	0	0	1	0	0	0	0	0	20	IVR rec error	When ABCD signal level exceeds the specified range
	0	1	0	0	0	0	0	0	40	CLV unlock	When CLV is unlocked
	1	0	0	0	0	0	0	0	80	Access fault	When access operation is not performed normally

### Reading the Display:

Convert the hexadecimal display into binary display. If more than two causes, they will be added.

### Example

When 42 is displayed:  
 Higher bit : 4 = 0100 → b6  
 Lower bit : 2 = 0010 → b1  
 In this case, the retry cause is combined of “CLV unlock” and “ader5”.

When A2 is displayed:  
 Higher bit : A = 1010 → b7+b5  
 Lower bit : 2 = 0010 → b2  
 The retry cause in this case is combined of “access fault”, “IVR rec error”, and “ader5”.

### Reading the Track Mode Display

Hexadecimal	Higher Bits				Lower Bits				Hexa- decimal	Details	
	8	4	2	1	8	4	2	1		When 0	When 1
Bit	b7	b6	b5	b4	b3	b2	b1	b0			
Binary	0	0	0	0	0	0	0	1	01	Emphasis OFF	Emphasis ON
	0	0	0	0	0	0	1	0	02	Monaural	Stereo
	0	0	0	0	0	1	0	0	04	This is 2-bit display. Normally 01.	
	0	0	0	0	1	0	0	0	08	01:Normal audio. Others:Invalid	
	0	0	0	1	0	0	0	0	10	Audio (Normal)	Invalid
	0	0	1	0	0	0	0	0	20	Original	Digital copy
	0	1	0	0	0	0	0	0	40	Copyright	No copyright
	1	0	0	0	0	0	0	0	80	Write prohibited	Write allowed

#### Reading the Display:

Convert the hexadecimal display into binary display. If more than two causes, they will be added.

Example When 84 is displayed:

Higher bit : 8 = 1000 → b7

Lower bit : 4 = 0100 → b2

In this case, as b2 and b7 are 1 and others are 0, it can be determined that the retry cause is combined of “emphasis OFF”, “monaural”, “original”, “copyright exists”, and “write allowed”.

Example When 07 is displayed:

Higher bit : 0 = 1000 → All 0

Lower bit : 7 = 0111 → b0+b1+b2

In this case, as b0, b1, and b2 are 1 and others are 0, it can be determined that the retry cause is combined of “emphasis ON”, “stereo”, “original”, “copyright exists”, and “write prohibited”.

#### Hexadecimal → Binary Conversion Table

Hexadecimal	Binary	Hexadecimal	Binary
0	0000	8	1000
1	0001	9	1001
2	0010	A	1010
3	0011	B	1011
4	0100	C	1100
5	0101	D	1101
6	0110	E	1110
7	0111	F	1111

## SECTION 2 GENERAL

### Front Panel

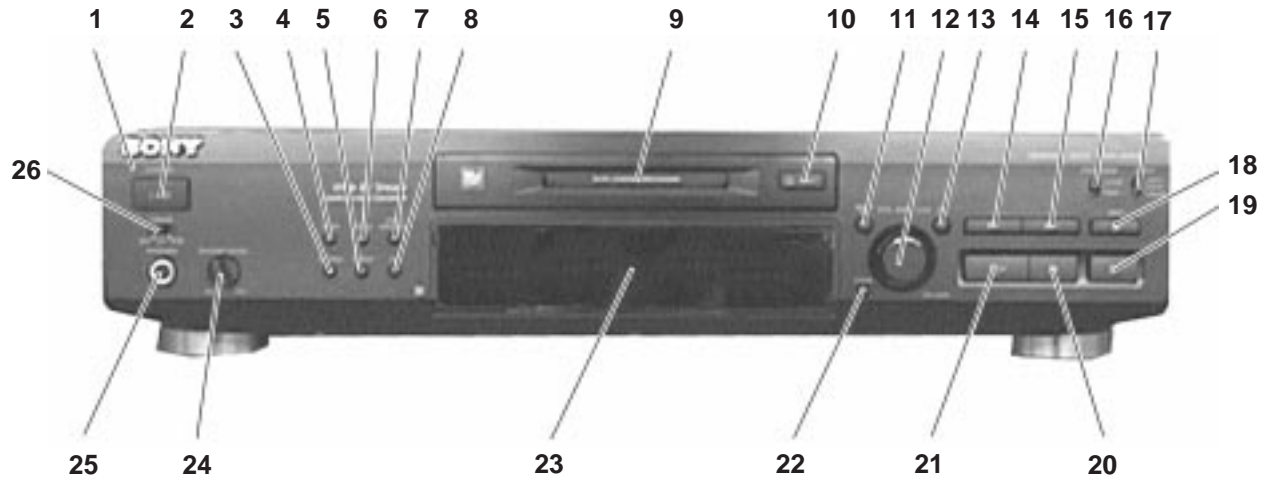

### Location of Parts and Controls

- 1 STANDBY indicator
- 2 I/⏻ button
- 3 PLAY MODE button
- 4 FADER button
- 5 REPEAT button
- 6 SCROLL button
- 7 LEVEL/DISPLAY/CHAR button
- 8 TIME button
- 9 DISK compartment
- 10 ≡ EJECT button
- 11 MENU/NO button
- 12 AMS knob
- 13 YES button
- 14 ◀ button
- 15 ▶ button
- 16 REC MODE switch
- 17 INPUT switch
- 18 ● REC (Recording) button
- 19 ■ (stop) button
- 20 || (Pause) button
- 21 ▷ (Play) button
- 22 CLEAR button
- 23 DISPLAY window
- 24 PHONE LEVEL knob
- 25 PHONES jack
- 26 TIMER switch

# Recording on an MD

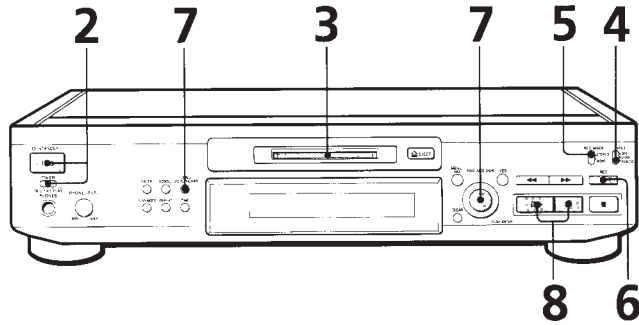

**1** Turn on the amplifier and play the program source you want to record.

**2** Press I/⏻.  
The STANDBY indicator turns off.

**3** Insert a recordable MD.

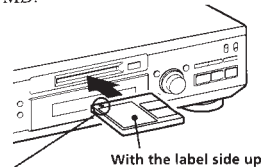

With the arrow pointing this way

If the MD has a recorded material on it, the deck will automatically start recording from the end of the last recorded track.

**4** Set INPUT to the corresponding input connector.

To record through	Set INPUT to
DIGITAL OPTICAL IN	OPT
DIGITAL COAXIAL IN	COAX
LINE (ANALOG) IN	ANALOG

**5** Set REC MODE to the mode you want to record in.

To record in	Set REC MODE*1 to
Stereo sound	STEREO
Monaural sound*2	MONO

\*1 If you switch REC MODE during recording or recording pause, recording stops.

\*2 In the monaural recording, you can record about two times longer than in the stereo recording.

**Monitor audio during recording**  
Even if you set REC MODE to MONO, the monitor signal does not become monaural.

### When "TOC Writing" flashes in the display

The deck is currently updating the Table Of Contents (TOC). Do not move the deck or pull out the AC power cord. Changes to an MD made through recording are saved only when you update the TOC by ejecting the MD or changing the deck to standby by pressing the I/⏻ switch.

**6** Press ● REC.  
The deck becomes ready to record.

**7** Press LEVEL/DISPLAY/CHAR to change the display, then turn AMS to adjust the recording level.  
For details, see pages 12 and 13.

**8** Press ▷ or ||.  
Recording starts.

**9** Start playing the program source.

### Do not disconnect the deck from the power source immediately after recording

If you do, recorded material may not be saved to the MD. To save the material, after recording, press ⏏ EJECT to take out the MD or change the deck to standby by pressing I/⏻. "TOC Writing" will flash in the display at this time.

After "TOC Writing" stops flashing and goes out, you can pull out the AC power cord.

To	Press
Stop recording	■
Pause recording*	. Press the button again or press ▷ to resume recording.
Take out the MD	⏏ EJECT after stopping

\* Whenever you pause recording, the track number increases by one. For example, if you paused recording while recording on track 4, the track number increases by one and recording continues on the new track when restarted.

### To protect an MD against accidental erasure

To make it impossible to record on an MD, slide the tab in the direction of arrow, opening the slot. To allow recording, close the slot.

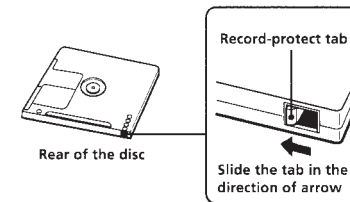

This section is extracted from instruction manual.

# Playing an MD

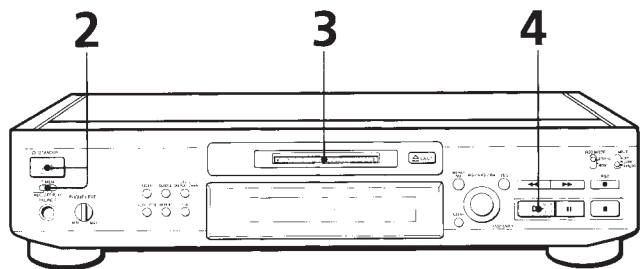

**You can locate and play back a track while the deck is stopped**

- 1 Turn AMS (or press ◀▶) until the number of the track you want to play appears.
- 2 Press AMS or ▷.

**To use headphones**  
Connect them to PHONES jack. Use PHONE LEVEL to adjust the volume.

**You can adjust the analog signal level output to the LINE (ANALOG) OUT jacks**

- 1 While the deck is playing, press LEVEL/DISPLAY/CHAR repeatedly until the line output adjustment display appears.
- 2 Turn AMS (or press LEVEL +/-) to adjust the output signal level.

**Notes**

- The output level for the PHONES jack is also changed.
- When you eject the MD or turn off the power by pressing the I/⏻ switch, the output level is reset to the initial setting (0.0dB).

**1** Turn on the amplifier and set the source selector to the position for MD deck.

**2** Press I/⏻.  
The STANDBY indicator turns off.

**3** Insert an MD.

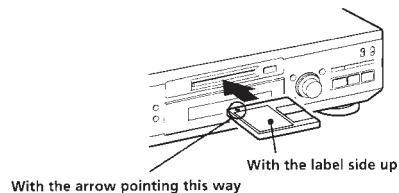

**4** Press ▷.  
The deck starts playing. Adjust the volume on the amplifier.

To	Do the following:
Stop playing	Press ■.
Pause playing	Press II. Press the button again or press ▷ to resume playing.
Go to the next track	Turn AMS clockwise (or press ▶▶ on the remote).
Go to the current track or the preceding track	Turn AMS counterclockwise (or press ◀◀ on the remote).
Take out the MD	Press ⏏ EJECT after stopping playing.

## Notes on Recording

**If "Protected" alternates with "C11" in the display**  
The MD is record-protected. Close the slot to record on the disc (see "To protect an MD against accidental erasure" on page 7).

**If "Din Unlock" alternates with "C71" in the display**

- The digital program source is not connected as you set with the INPUT switch in Step 4 on page 6. To continue, connect the program source properly.
- The program source is not on. Turn on the program source.

**Depending on the menu settings and source being recorded, track numbers are marked in following ways:**

- When recording from a CD or MD with the INPUT switch set at a digital position (OPT or COAX) and the source connected through the digital input (DIGITAL OPTICAL IN or DIGITAL COAXIAL IN) connector:  
The deck automatically marks track numbers in the same sequence as the original. If, however, a track is repeated two or more times (e.g. by single-track repeat play) or two or more tracks with the same track number (e.g. from different MDs or CDs) are played, the track or tracks are recorded as part of a single, continuous track with a single track number. If the source is an MD, track numbers may not be marked for tracks of less than 4 seconds.
- When recording from some CD players and multi disc players connected through one of the digital input connectors with the INPUT switch set at the respective digital position:  
The deck may not automatically mark track numbers. In these cases, mark the track numbers after recording, using the deck's Divide Function (see "Dividing Recorded Tracks" on page 31).
- When recording from a source connected through the LINE (ANALOG) IN jacks with the INPUT switch set at ANALOG or when recording from a DAT or satellite broadcast connected through one of the digital input connectors with the INPUT switch set at the respective digital position and "1.Mark Off" selected in Setup Menu 02:  
The source will be recorded as a single track.
- Even while recording an analog source or a DAT or satellite broadcast, you can mark track numbers if "T.Mark LSyn" is selected in Setup Menu 02 (see "Marking Track Numbers While Recording" on page 13).

- When recording from DAT or satellite broadcasts with the INPUT switch set at the respective digital position, the deck automatically marks a track number whenever the sampling frequency of the input signal changes regardless of the Setup Menu 02 setting.

**You can mark track numbers during or after recording**  
For details, see "Marking Track Numbers While Recording" (page 13) and "Dividing Recorded Tracks" (page 31).

**When "TOC Writing" flashes in the display**  
The deck is currently updating the Table Of Contents (TOC). Do not move the deck or pull out the AC power cord. Changes to an MD made through recording are saved only when you update the TOC by ejecting the MD or changing the deck to standby by pressing the I/⏻ switch.

**The MD deck uses the SCMS (Serial Copy Management System on page 41)**  
MDs recorded through digital input connector cannot be copied onto other MDs or DAT tapes through the digital output connector.

**When recording digital signals that have been emphasized (in the higher frequencies)**  
The signal is automatically de-emphasized (with attenuation proportional to the degree of emphasis) and the level of the de-emphasized signal is indicated on the peak level meters.

**When the deck is recording or in recording pause, digital signals input through one of the digital input connectors are output to the DIGITAL OPTICAL OUT connector with the same sampling rate**  
To change the digital input signal to another sampling rate for output (without recording it to an MD), use Input Monitor Function (see page 10).

## Useful Tips for Recording

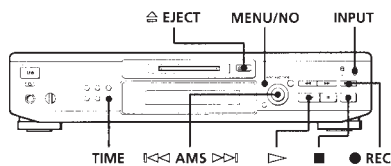

### Checking the remaining recordable time on the MD

Press TIME.

- When you press the TIME button repeatedly while recording, the display alternates between the recording time of the current track and the remaining recordable time on the MD.
- When you press the TIME button repeatedly while the deck is stopped, the display alternates between total disc playing time and remaining recordable time on the MD (see page 19).

### Monitoring the input signal (Input Monitor)

Before starting recording, you can monitor the selected input signal through the deck's output connectors.

- 1 Press **EJECT** to remove the MD.
- 2 Set INPUT according to the input signal you want to monitor.
 

**When the INPUT switch is set at ANALOG**  
The analog signal input through the LINE (ANALOG) IN jacks is output to the DIGITAL OPTICAL OUT connector after A/D conversion, and then to the LINE (ANALOG) OUT jacks and the PHONES jack after D/A conversion.

**When the INPUT switch is set at OPT or COAX**  
After passing through the sampling rate converter, the digital signal input through the respective digital input connector is output to the DIGITAL OPTICAL OUT connector, and after D/A conversion to the LINE (ANALOG) OUT jacks and PHONES jack.
- 3 Press **REC**.  
If the INPUT switch is set at ANALOG, "AD-DA" appears in the display.  
If the INPUT switch is set at OPT or COAX, "-DA" appears in the display.

### If "Auto Cut" appears in the display (Auto Cut)

There has been no sound input for about 30 seconds during recording. The 30 seconds of silence are replaced by a blank of about 3 seconds and the deck changes to recording pause.  
If the deck continues pausing for about 10 minutes after the Auto Cut Function activated, recording stops automatically.  
Note that this function does not activate even if there has been no sound input for about 30 seconds when the deck started recording from the blank portion.

- You can turn off the Auto Cut Function**  
For details, see "To turn off the Smart Space Function and Auto Cut Function" below. Note that when you turn off the Auto Cut Function, the Smart Space Function is turned off automatically.

### If "Smart Space" appears in the display (Smart Space)

There has been an extended silence of 4 to 30 seconds in length during recording. The silence is replaced with a blank of about 3 seconds and the deck continues recording. Note that new track numbers may not be marked for portions recorded while this function is activated. Also, the Smart Space Function does not activate even if there has been an extended silence of 4 to 30 seconds in length when the deck started recording from the blank portion.

#### To turn off the Smart Space Function and Auto Cut Function

- 1 While the deck is stopped, press MENU/NO twice to display "Setup Menu".
- 2 Turn AMS to select "Setup 05", then press AMS.
- 3 Turn AMS to select "S.Space Off", then press AMS.
- 4 Press MENU/NO.

#### To turn on the Smart Space Function and Auto Cut Function again

- 1 Do Steps 1 and 2 in "To turn off the Smart Space Function and Auto Cut Function" above.
- 2 Turn AMS to select "S.Space On", then press AMS.
- 3 Press MENU/NO.

#### Notes

- When you turn off the Smart Space Function, the Auto Cut Function is also turned off automatically.
- The Smart Space Function and Auto Cut Function are factory set to on.
- If you turn off the deck or disconnect the AC power cord, the deck will recall the last setting (On or Off) of the Smart Space and Auto Cut Functions the next time you turn on the deck.

### Playing back tracks just recorded

Do this procedure to immediately play back tracks that have just been recorded.

Press **▷** immediately after stopping recording. Playback starts from the first track of the material just recorded.

#### To play from the first track of the MD after recording

- 1 Press **■** again after stopping recording.
- 2 Press **▷**.  
Playback starts from the first track of the MD.

## Recording Over Existing Tracks

Follow the procedure below to record over existing material just as you would on an analog cassette tape.

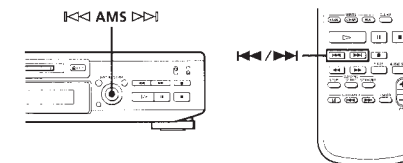

- 1 Do Steps 1 to 5 in "Recording on an MD" on page 6.
- 2 Turn AMS (or press **◀◀** or **▶▶**) until the number of the track to be recorded over appears.
- 3 To record from the start of the track, continue from Step 6 in "Recording on an MD" on page 7.

- While "Tr" flashes in the display**  
The deck is recording over an existing track, and stops flashing when it reaches the end of the recorded portion.

- To record from the middle of the track**
- 1 After Step 2 above, press **▷** to start playback.
  - 2 Press **||** where you want to start recording.
  - 3 Continue from Step 6 in "Recording on an MD" on page 7.

#### Note

You cannot record from the middle of an existing track when the "PROGRAM" or "SHUFFLE" is on.

## Adjusting the Recording Level

You can adjust the recording level before starting recording.

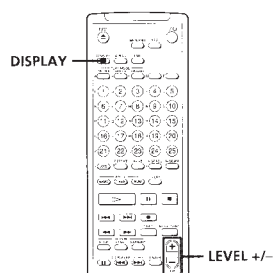
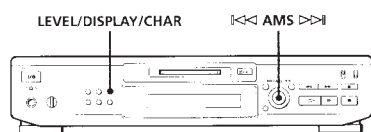

### Adjusting the digital recording level

- Do Steps 1 to 6 in "Recording on an MD" on pages 6 and 7.  
Set INPUT to OPT or COAX in Step 4.
- Play the portion of the program source with the strongest signal level.
- Press LEVEL./DISPLAY/CHAR (or DISPLAY) repeatedly until the recording level adjustment display appears.

- While monitoring the sound, turn AMS (or press LEVEL +/- repeatedly) to adjust the recording level so that the peak level meters reach their highest point without turning on the OVER indication. Occasional lighting of "OVER" is acceptable.

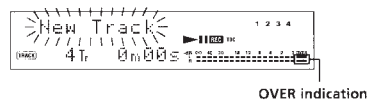

The volume can only be increased up to +12.0 dB. Therefore, if the digital signal level of the program source is low, it may not be possible to set the recording level to maximum.

- Stop playing the program source.
- To start recording, do the procedure starting from Step 8 in "Recording on an MD" on page 7.

### You can use Setup Menu 11 or 12 to adjust the digital recording level

- While recording or in recording pause, press MENU/NO twice to display "Setup Menu".
- Turn AMS to select "Setup 11" or "Setup 12", then press AMS. The dB display flashes.
- Turn AMS to adjust the recording level, then press AMS. The dB display changes from flashing to lighted steadily.
- Press MENU/NO.

### The Peak Hold Function freezes the level meter display at the highest level reached by the input signal

- While the deck is stopped, press MENU/NO twice to display "Setup Menu".
- Turn AMS to select "Setup 06", then press AMS.
- Turn AMS to select "P.Hold On", then press AMS.
- Press MENU/NO.

To turn off the Peak Hold Function, select "P.Hold Off" in Step 3 above.

## Adjusting the analog recording level

- Do Steps 1 to 6 in "Recording on an MD" on pages 6 and 7.  
Set INPUT to ANALOG in Step 4.
- Play the portion of the program source with the strongest signal level.
- Press LEVEL./DISPLAY/CHAR (or DISPLAY) repeatedly until the recording level adjustment display appears.
- While monitoring the sound, turn AMS (or press LEVEL +/- repeatedly) to adjust the recording level.  
The volume can only be increased up to +12.0 dB. Therefore, if the output level of the connected component is low, it may not be possible to set the recording level to maximum.
- Stop playing the program source.
- To start recording, do the procedure starting from Step 8 in "Recording on an MD" on page 7.

### You can use Setup Menu 10 to adjust the analog recording level

- While recording or in recording pause, press MENU/NO twice to display "Setup Menu".
- Turn AMS to select "Setup 10", then press AMS.
- Turn AMS to adjust the recording level, then press AMS.
- Press MENU/NO.

## Marking Track Numbers While Recording (Track Marking)

You can mark track numbers either manually or automatically. By marking track numbers at specific points, you can quickly locate the points later using the AMS Function, or use various Editing Functions.

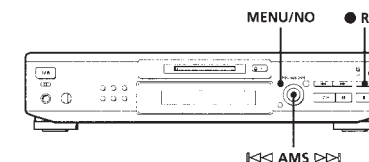

### Marking track numbers manually (Manual Track Marking)

You can mark track numbers at any time while recording on an MD.

Press ● REC at the place you want to add a track mark while recording.

### Marking track numbers automatically (Automatic Track Marking)

The deck adds track marks differently in the following cases:

- When recording from CDs or MDs with the INPUT switch set at OPT or COAX:  
The deck marks track numbers automatically. However, the Automatic Track Marking Function does not activate when recording from some CD players and multi disc players.
- In all other cases:  
If "T.Mark LSyn" is selected in Setup Menu 02, the deck marks a new track number whenever the signal drops to the specified level or below for about 1.5 seconds or longer, then rises to a specified level.

(Continued)



To select "T.Mark Off" or "T.Mark L.Syn" in Setup Menu 02, do the procedure below:

- 1 While the deck is stopped, press MENU/NO twice to display "Setup Menu".
- 2 Turn AMS to select "Setup 02", then press AMS.
- 3 Turn AMS to select "T.Mark Off" or "T.Mark L.Syn", then press AMS. "L.SYNC" lights up when you select "T.Mark L.Syn".
- 4 Press MENU/NO.

**You can set the reference level that must pass before a rise marks a new track number**

In Automatic Track Marking, the input signal must remain at or below a given reference level for 1.5 seconds or longer before a rise above the reference level will mark a new track number.

Do the following procedure to specify the reference level. Note that "T.Mark L.Syn" should be selected in Setup Menu 02.

- 1 While the deck is stopped, press MENU/NO twice to display "Setup Menu".
- 2 Turn AMS to select "Setup 03", then press AMS.
- 3 Turn AMS to set the reference level. You can set the reference level at -72 dB to 0 dB in 2 dB steps.
- 4 After selecting the reference level, press AMS.
- 5 Press MENU/NO.

**Note**

If you turn off the deck or disconnect the AC power cord, the deck will recall the last settings of the Automatic Track Marking Function ("T.Mark L.Syn" or "T.Mark Off") the next time you turn on the deck.

## Starting Recording With 6 Seconds of Prestored Audio Data (Time Machine Recording)

When recording from an FM or satellite broadcast, the first few seconds of material are often lost due to the time it takes you to ascertain the contents and press the record button. To prevent the loss of this material, the Time Machine Recording Function constantly stores 6 seconds of the most recent audio data in a buffer memory so that when you begin recording the program source using this function, the recording actually begins with the 6 seconds of audio data stored in the buffer memory in advance as shown in the illustration below.

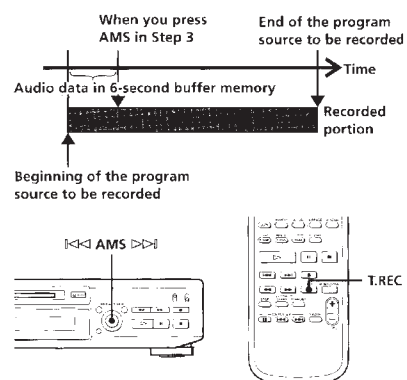

- 1 Do Steps 1 to 6 in "Recording on an MD" on pages 6 and 7. The deck changes to recording pause.
- 2 Start playing the program source you want to record. The most recent 6 seconds of audio data is stored in the buffer memory.
- 3 Press AMS (or T.REC) to start Time Machine Recording. Recording of the program source starts with the 6 seconds of audio data stored in the buffer memory.

### To stop Time Machine Recording

Press ■.

**Note**

The deck starts storing audio data when the deck is in recording pause and you start playing the program source. With less than 6 seconds of playing of the program source and audio data stored in the buffer memory, Time Machine Recording starts with less than 6 seconds of audio data.

## Synchro-Recording With Audio Equipment of Your Choice (Music Synchro-Recording)

By using the MUSIC SYNC button on the remote, you can automatically start recording in sync with the signal input from the program source.

The method of marking track numbers differs, depending on the program source being recorded and the setting of the Setup Menu 02 (see "Notes on Recording" on page 9).

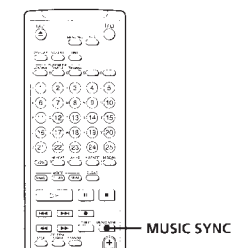

- 1 Do Steps 1 to 5 in "Recording on an MD" on page 6.
- 2 Press MUSIC SYNC. The deck changes to recording pause.
- 3 Start playing the program source you want to record. The deck starts recording automatically.

### To stop Music Synchro-Recording

Press ■.

**Note**

When Music Synchro-Recording, the Smart Space Function and the Auto Cut Function turn on automatically regardless of their setting (On or Off) and type of input (digital or analog).



## Synchro-Recording With a Sony CD Player

By connecting your deck to a Sony CD player or Hi-Fi Component System, you can easily dub CDs onto MDs using the CD synchro buttons on the remote. If your deck is connected to a Sony CD player by a digital input cable, track numbers are automatically marked as appear on the original even when "T.Mark Off" is selected in Setup Menu 02. If your deck is connected to a Sony CD player by audio connecting cords through the LINE (ANALOG) IN jacks, track numbers are automatically marked when you set Setup Menu 02 to "T.Mark LSyn" (see page 13). As the same remote controls both the CD player and the deck, you may have trouble operating both units if they are far from each other. If you do, place the CD player close to this deck.

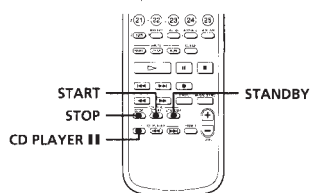

- 1 Set the source selector on the amplifier to CD.
- 2 Do Steps 2 to 5 in "Recording on an MD" on page 6 to prepare the deck for recording.
- 3 Insert a CD into the CD player.
- 4 Select the playback mode (Shuffle Play, Program Play, etc.) on the CD player.
- 5 Press STANDBY.  
The CD player pauses for playing and the deck pauses for recording.
- 6 Press START.  
The deck starts recording and the CD player starts playback.  
The track number and elapsed recording time of the track appear in the display.

### If the CD player does not start playing

Some CD player models may not respond when you press START on the remote of the deck. Press **II** on the remote of the CD player instead.

- 7 Press STOP to stop synchro-recording.

### To pause recording

Press STANDBY or CD PLAYER **II**.  
To restart recording, press START or CD PLAYER **II**.  
A new track number is marked each time you pause recording.

### Notes

- When the deck's remote controls the CD player with a mode selector, set the selector to CD1.
- The deck may not automatically mark track numbers when recording from some CD players and multi disc players.

### You can use the remote of the CD player during synchro-recording

When you press **II**, the CD player stops and the deck pauses for recording.

When you press **II**, the CD player pauses and the deck pauses for recording.

To restart synchro-recording, press **▷**.

### You can change CDs during synchro-recording

Do the following steps instead of Step 7 above.

- 1 Press **II** on the remote of the CD player.  
The deck pauses for recording.
- 2 Change the CD.
- 3 Press **▷** on the remote of the CD player.  
Synchro-recording restarts.

### You can also do synchro-recording with a Sony video CD player

Using the procedure for synchro-recording with a Sony CD player, you can do synchro-recording with a Sony video CD player also.

To select the video CD player, press button number 2 while pressing down the I/⏏ button on the remote before starting the procedure.

To select the CD player again, press button number 1 while pressing down the I/⏏ button.

The deck is factory set to a CD player for synchro-recording.

### You can check the remaining recordable time on the MD

Press TIME (see page 19).

## Fading In and Out (Fader)

You can gradually increase the recording level at the beginning of a recording (fade-in recording) or gradually decrease the recording level at the end of a recording (fade-out recording).

This function is convenient when, for example, you don't want the track cut off abruptly when the disc reaches to its end.

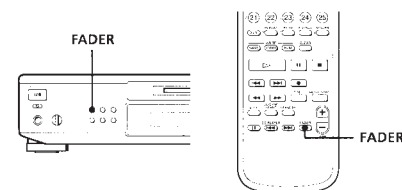

### Fade-in recording

During recording pause, press FADER at the position where you want to start fade-in recording.

◀ in "Fade ◀ 3.2s" flashes and the deck performs the fade-in recording until the counter reaches "0.0s".

### Fade-out recording

During recording, press FADER at the position where you want to start fade-out recording.

▶ in "Fade ▶ 3.2s" flashes and the deck performs the fade-out recording until the counter reaches "0.0s".

The deck changes to recording pause when fade-out recording finishes.

### You can set the duration of fade-in and fade-out recording independently

1 While the deck is stopped, press MENU/NO twice to display "Setup Menu".

2 To set the duration of fade-in recording:  
Turn AMS to select "Setup 08", then press AMS.

To set the duration of fade-out recording:  
Turn AMS to select "Setup 09", then press AMS.

3 Turn AMS to set the duration.  
Both the fade-in and fade-out recording durations can be set in 0.1 second steps.

4 After selecting the duration, press AMS.

5 Press MENU/NO.

## Recording on an MD Using a Timer

By connecting a timer (not supplied) to the deck, you can start and stop recording operations at specified times. For further information on connecting the timer and setting the starting and ending times, refer to the instructions that came with the timer.

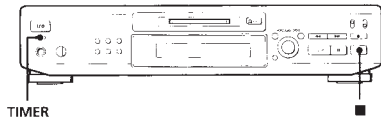

- 1 Do Steps 1 to 7 in "Recording on an MD" on pages 6 and 7.
- 2
  - If you want to specify the time for the start of recording, press ■.
  - If you want to specify the time for the end of recording, do Steps 8 and 9 in "Recording on an MD" on page 7.
  - If you want to specify the time for both start and end of recording, press ■.
- 3 Set TIMER on the deck to REC.
- 4 Set the timer as required.
  - When you have set the time for the start of recording, the deck turns off. When the specified time arrives, the deck turns on and starts recording.
  - When you have set the time for the end of recording, recording continues. When the specified time arrives, the deck stops recording and turns off.
  - When you have set the time for both the start and end of recording, the deck turns off. When the starting time arrives, the deck turns on and starts recording. When the ending time arrives, the deck stops recording and turns off.

- 5 After you have finished using the timer, set TIMER on the deck to OFF. Then place the deck in standby status by plugging the AC power cord of the deck into a wall outlet or set the timer to continuous operation.
  - If TIMER is left at REC, the deck will automatically start recording the next time you turn the deck on.
  - If you do not change the deck to standby status for more than a week after timer recording has finished, the recorded contents may disappear.

**Make sure to change the deck to standby status within a week after timer recording is completed**  
 The TOC on the MD is updated and recorded contents are written to the MD when you turn the deck on. If the recorded contents have disappeared, "Standby" flashes when you turn the deck on.

- Notes**
- It may take about 30 seconds after the deck is turned on until recording starts. When recording at a specified time using the timer, be sure to take this time into account when setting the recording start time.
  - During timer recording, new material is recorded from the end of the recorded portion on the MD.
  - Material recorded during timer recording will be saved to the disc the next time you turn the deck on. "IOE Writing" will flash in the display at that time. Do not move the deck or pull out the AC power cord while "IOE Writing" is flashing.
  - Timer recording will stop if the disc becomes full.

## Using the Display

You can use the display to check disc and track information such as the total track number, total playing time of the tracks, remaining recordable time of the disc and disc name.

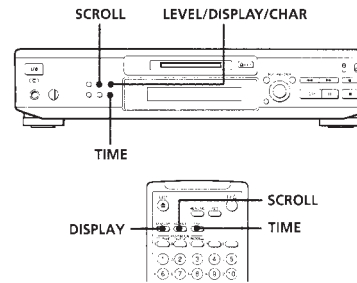

### Checking the total track number, total disc playing time and remaining recordable time of the disc

Each time you press TIME while the deck is stopped, you can change the display as follows:

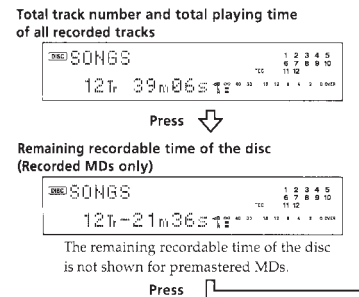

When you insert an MD, the disc name, total number of tracks, total disc playing time, and the music calendar appear in the display as follows:

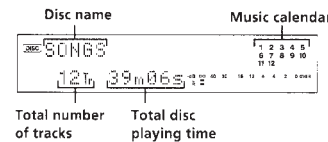

A music calendar shows all the track numbers within a grid if the MD is a premastered disc, or without a grid if the MD is a recordable disc. If the total track number exceeds 15, ► appears to the right of number 15 in the music calendar.

**Note**  
 When you insert a new MD or turn off the deck and turn it on again, the last item displayed will reappear.

### Checking the playing time, remaining time, and track number

Each time you press TIME while playing an MD, you can change the display as shown below. The track numbers in the music calendar disappear after they are played.

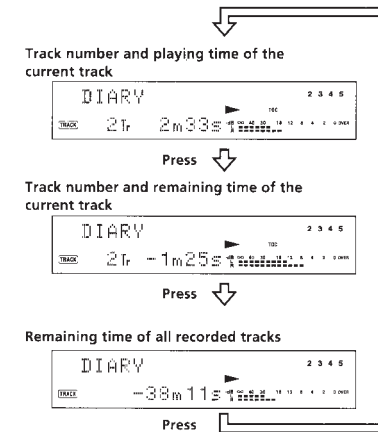

**Lightbulb icon:** The track name and disc name are displayed as follows:  
 The disc name appears whenever the deck is stopped, and the name of the current track appears when the track is playing. If no title is recorded, "No Name" appears instead of a title.  
 To label a recordable disc and its tracks, see "Labeling Recordings" on page 33.

(Continued)

**💡 You can scroll a title of more than 12 characters**  
 Press SCROLL.  
 Since the display shows up to 11 characters at a time, press SCROLL to see the rest of the title if the title has 12 characters or more.  
 Press SCROLL again to pause scrolling, and again to continue scrolling.

### Changing the display

Each time you press LEVEL/DISPLAY/CHAR (or DISPLAY) while the deck is stopped or playing, you can change the display as follows:

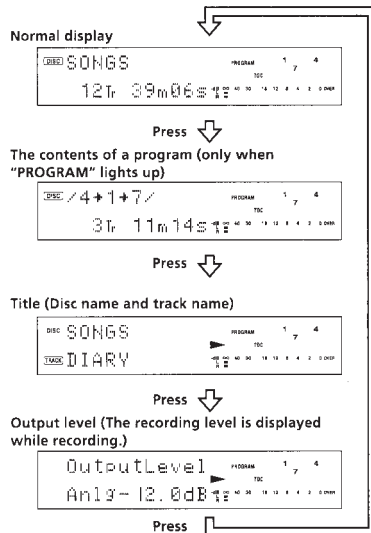

### Locating a Specific Track

You can quickly locate any track while playing a disc by using the AMS (Automatic Music Sensor) control, **⏮** and **⏭** buttons, number buttons, or M.SCAN button on the remote.

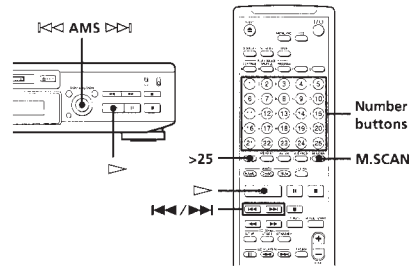

To locate	Do the following:
The next or succeeding tracks	During playback, turn AMS clockwise (or press <b>⏭</b> repeatedly) until you find the track.
The current or preceding tracks	During playback, turn AMS counterclockwise (or press <b>⏮</b> repeatedly) until you find the track.
A specific track directly	Press number buttons to enter the track number.
A specific track by using AMS	<ol style="list-style-type: none"> <li>1 Turn AMS until the track number you want to locate appears while the deck is stopped. (The track number is flashing.)</li> <li>2 Press AMS or <b>▶</b>.</li> </ol>
By scanning each track for 6 seconds (music scan)	<ol style="list-style-type: none"> <li>1 Press M.SCAN before you start playing.</li> <li>2 When you find the track you want, press <b>▶</b> to start playing.</li> </ol>

**💡 When you directly locate a track with a number over 25**  
 You must press >25 first, before entering the corresponding digits.  
 Press >25 once if it is a 2-digit track number, and twice if it is a 3-digit track number.  
 To enter "0", press button 10.  
 Examples:
 

- To play track number 30  
 Press >25 once, then 3 and 10.
- To play track number 100  
 Press >25 twice, then 1, 10 and 10.

### Locating a Particular Point in a Track

You can also use the **⏮** and **⏭** buttons to locate a particular point in a track during playback or playback pause.

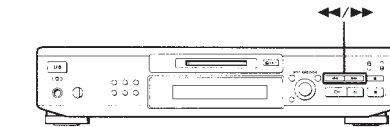

**💡 You can extend the playing time during music scan**  

- 1 While the deck is stopped, press MENU/NO twice to display "Setup Menu".
- 2 Turn AMS to select "Setup 07", then press AMS.
- 3 Turn AMS to select the playing time within a range of 6 to 20 seconds (in 1 second steps), then press AMS.
- 4 Press MENU/NO.

**💡 To pause playing at the beginning of a track**  
 Turn AMS (or press **⏮** or **⏭**) after pausing playback.

**💡 To go quickly to the beginning of the last track**  
 Turn AMS counterclockwise (or press **⏮**) while the display shows the total track number, total disc playing time or remaining recordable time of the disc (recordable disc only), or disc name (see page 19).

To locate a point	Press
While monitoring the sound	<b>⏭</b> (forward) or <b>⏮</b> (backward) and keep pressing until you find the point.
Quickly by observing the display during playback pause	<b>⏭</b> or <b>⏮</b> and keep pressing until you find the point. There is no sound output during this operation.

**💡 If "—Over—" appears while you are pressing **⏭** during playback pause**  
 The disc has reached its end. Press **⏮** (or **⏮**) or turn AMS counterclockwise to go back.

#### Notes

- If the disc reaches the end while you are pressing **⏭** during sound monitoring, the deck stops.
- Tracks that are only a few seconds long may be too short to scan using the search function. For such tracks, it is better to play the MD at normal speed.

## Playing Tracks Repeatedly

You can play tracks repeatedly in any play mode.



Press REPEAT.  
 "REPEAT" appears in the display.  
 The deck repeats the tracks as follows:

When the MD is played in	The deck repeats
Normal play (page 8)	All the tracks
Shuffle Play (page 23)	All the tracks in random order
Program Play (page 23)	The same program

### To cancel repeat play

Press REPEAT several times until "REPEAT" disappears.  
 The deck returns to the original playing mode.

## Repeating the current track

While the track you want to repeat is playing in normal, Shuffle, or Program Play, press REPEAT several times until "REPEAT 1" appears in the display.

## Repeating a specific portion (A-B Repeat)

You can play a specific portion of a track repeatedly. This might be useful when you want to memorize lyrics. Note that you can only repeat a portion within the boundaries of a single track.

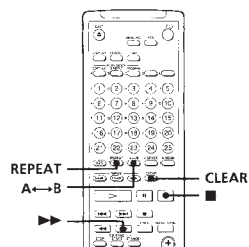

- 1 While playing a disc, press A↔B at the starting point (point A) of the portion to be played repeatedly.  
 "REPEAT A-" appears and "B" flashes in the display.
- 2 Continue playing the track or press ►► until you reach the ending point (point B), then press A↔B again.  
 "REPEAT A-B" lights continuously. The deck starts to play the specified portion repeatedly.

### To cancel A-B Repeat

Press REPEAT, CLEAR or ■.

### Setting new starting and ending points

You can repeat the portion immediately after the currently specified portion by changing the starting and ending points.

- 1 Press A↔B while "REPEAT A-B" appears.  
 The current ending point B becomes the new starting point A, "REPEAT A-" lights continuously, and "B" flashes in the display.
- 2 Continue playing the track or press ►► until you reach the new ending point (point B), then press A↔B again.  
 "REPEAT A-B" lights continuously and the deck starts playing repeatedly the newly specified portion.

## Playing in Random Order (Shuffle Play)

You can have the deck "shuffle" tracks and play them in random order.



- 1 Press PLAY MODE repeatedly (or SHUFFLE once) until "SHUFFLE" appears in the display when the deck is stopped.
- 2 Press ► to start Shuffle Play.  
 "Shuffle" and "E" appear in the display while the deck is "shuffling" the tracks.

### To cancel Shuffle Play

Press PLAY MODE repeatedly (or CONTINUE once) when the deck is stopped until "SHUFFLE" disappears.

### You can specify tracks during Shuffle Play

- To play the next track, turn AMS clockwise (or press ►►).
- To play from the beginning of the current track again, turn AMS counterclockwise (or press ◀◀). You cannot use AMS (or ◀◀) to go to tracks that have already been played.

## Creating Your Own Program (Program Play)

You can specify the playback order of the tracks on an MD and create your own programs containing up to 25 tracks.

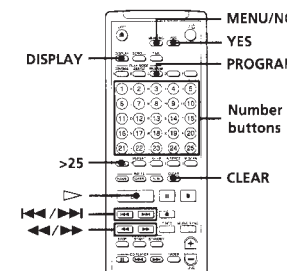
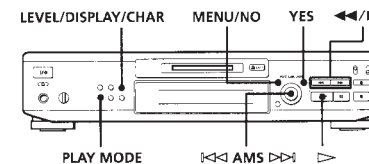

- 1 While the deck is stopped, press MENU/NO twice to display "Setup Menu".
- 2 Turn AMS to display "Program ?", then press AMS.
- 3 Do either a) or b):  
**a) When using the controls on the deck**
  - 1 Turn AMS until the track number you want appears in the display.
  - 2 Press AMS.

### If you enter the wrong track number

Press ◀◀ or ►► until the wrong track number flashes, turn AMS to set the correct track number, then press AMS.  
 If "0" flashes, press ◀◀.

(Continued)

**b) When using the remote**

Press the number buttons to enter the tracks you want to program in the order you want. To program a track with a number over 25, use the >25 button (see page 20).

**If you enter the wrong track number**

Press ◀ or ▶ until the wrong track number flashes, then enter the correct track number with the number buttons.

If "0" flashes, press ◀.

- 4 Repeat Step 3 to enter other tracks. The entered track is added to the location where the "0" flashes. Each time you enter a track, the total program time is added up and appears in the display.
- 5 After finishing programming, press YES. "Complete!!" appears and programming is completed.
- 6 Press PLAY MODE repeatedly (or PROGRAM once) until "PROGRAM" appears in the display.
- 7 Press ▷ to start Program Play.

**To cancel Program Play**

Press PLAY MODE repeatedly (or CONTINUE once) when the deck is stopped until "PROGRAM" disappears.

**The program remains even after Program Play ends**  
When you press ▷, you can play the same program again.

**Notes**

- The display shows "- m - s" instead of the total playing time when the total playing time of the program exceeds 199 minutes.
- "ProgramFull" appears when you program over 25 tracks. Erase the unnecessary tracks to enter other tracks.

**Checking the track order**

While the deck is stopped and "PROGRAM" is on, press LEVEL/DISPLAY/CHAR (or DISPLAY) several times.

The track numbers appear in the order they were programmed as follow:

"/3 → 5 → 8 → 1 → 2/"

**To check the rest of the track order**

Turn AMS.

You can scroll the display to check all the track numbers you programmed.

**Changing the track order**

You can change the order of the tracks in your program before you start playing.

To		Do the following procedure after Steps 1 and 2 in "Creating Your Own Program":
Erase	a track	Press ◀ or ▶ until the track number you want to erase flashes, then press CLEAR.
	the whole program	Keep pressing CLEAR until all programmed track numbers disappear.
Add a track	to the beginning of the program	1 Press ◀ until "0" flashes at the left of the first track. 2 Do Steps 3 to 5 on pages 23 and 24.
	in the middle of the program	1 Press ◀ or ▶ until the track which precedes the track to be added flashes. 2 Press AMS so that "0" flashes, then do Steps 3 to 5 on pages 23 and 24.
	to the end of the program	1 Press ◀ until "0" flashes at the right of the last track. 2 Do Steps 3 to 5 on pages 23 and 24.
Change a track in the program		1 Press ◀ or ▶ until the track number you want to change flashes. 2 Do Steps 3 to 5 on pages 23 and 24.

**Useful Tips When Recording From MDs to Tape**

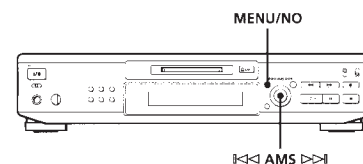

**Inserting blank spaces while recording to tape (Auto Space)**

The Auto Space Function inserts a 3-second blank space between each track while recording from MDs to tapes, allowing you to use the AMS function during later playback.

- 1 While the deck is stopped, press MENU/NO twice to display "Setup Menu".
- 2 Turn AMS to select "Setup 04", then press AMS.
- 3 Turn AMS to select "Auto Space", then press AMS.
- 4 Press MENU/NO.

**You can turn on the Auto Space Function using the remote**  
While the deck is stopped, press A.SPACE repeatedly until "Auto Space" appears in the display.

**To cancel Auto Space**

**Cancelling the function through menu operation on the deck**

- 1 Do Steps 1 and 2 in "Inserting blank spaces while recording to tape" on this page.
- 2 Turn AMS to select "Auto Off", then press AMS.
- 3 Press MENU/NO.

**Cancelling the function using the remote**

While the deck is stopped, press A.SPACE repeatedly until "Auto Off" appears.

**Note**

If the Auto Space Function is on while recording a selection containing multiple track numbers, (for example, a medley or symphony), blank spaces will be inserted within the selection whenever the track number changes.

**Pausing after each track (Auto Pause)**

When the Auto Pause Function is on, the deck pauses after playing each track. Auto Pause is convenient when recording single tracks or multiple, nonconsecutive tracks.

Select "Auto Pause" instead of "Auto Space" in Step 3 on "Inserting blank spaces while recording to tape" on this page.

**You can turn on the Auto Pause Function using the remote**  
While the deck is stopped, press A.SPACE repeatedly until "Auto Pause" appears in the display.

**To restart playback**

Press ▷ or II.

**To cancel Auto Pause**

**Cancelling the function through a menu operation on the deck**

Do Steps 1 to 3 in "To cancel Auto Pause" on this page.

**Cancelling the function using the remote**

While the deck is stopped, press A.SPACE repeatedly until "Auto Off" appears.

**Note**

If you turn off the deck or disconnect the AC power cord, the deck will recall the last setting of the Auto Space and Auto Pause Functions the next time you turn on the deck.

**Adjusting the analog signal level**

You can adjust the level of an analog signal for output to an amplifier connected through the LINE (ANALOG) OUT jacks.

- 1 While the deck is stopped, press MENU/NO twice to display "Setup Menu".
- 2 Turn AMS to select "Setup 13", then press AMS.
- 3 Turn AMS to adjust the analog output level.
- 4 Press AMS.
- 5 Press MENU/NO.

**To return to the initial setting (0.0dB)**

Press CLEAR.

**Notes**

- The analog signal level for output to the headphones connected through the PHONES jack is also changed.
- When you eject the MD or turn off the power by pressing the I/O switch, the output level is reset to the initial setting (0.0dB).

## Fading In and Out (Fader)

You can gradually increase the playback level of the signal output to the LINE (ANALOG) OUT jacks and the PHONES jack at the beginning of a playback (fade-in playback) or gradually decrease the playback level at the end of a playback (fade-out playback).

This function is convenient when, for example, you want to start or end playback in the middle of the track.

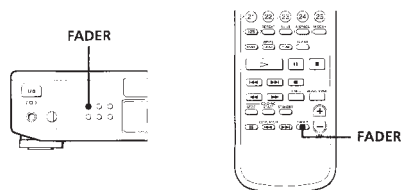

### Fade-in playback

During playback pause, press FADER at the position where you want fade-in playback to start.

◀ in "Fade ◀ 3.2s" flashes and the deck performs fade-in playback until the counter reaches to "0.0s".

### Fade-out playback

During playback, press FADER at the position where you want fade-out playback to start.

▶ in "Fade ▶ 3.2s" flashes and the deck performs fade-out playback until the counter reaches "0.0s".

The deck changes to playback pause when fade-out playback finishes.

#### Note

The signal level output to the DIGITAL OPTICAL OUT connector does not change.

#### 💡 You can set the duration of fade-in and fade-out playback independently

Do Steps 1 to 5 in "You can set the duration of the fade-in and fade-out recording independently" on page 17.

## Playing an MD Using a Timer

By connecting a timer (not supplied) to the deck, you can start and stop playback operations at specified times. For further information on connecting the timer or setting the starting and ending times, refer to the instructions that came with the timer.



- 1 Do Steps 1 to 3 in "Playing an MD" on page 8.
- 2 Press PLAY MODE repeatedly (or one of the PLAY MODE buttons once) to select the play mode you want.  
To play only specific tracks, create a program (see page 23).
- 3
  - If you want to specify the time for the start of playback, go to Step 4.
  - If you want to specify the time for the end of playback, press ▷ to start playback, then go to Step 4.
  - If you want to specify the time for both start and end of playback, go to Step 4.
- 4 Set TIMER on the deck to PLAY.
- 5 Set the timer as required.
  - When you have set the time for the start of playback, the deck turns off. When the specified time arrives, the deck turns on and starts playing.
  - When you have set the time for the end of playback, playback continues. When the specified time arrives, the deck stops playing and turns off.
  - When you have set the time for both the start and end of playback, the deck turns off. When the starting time arrives, the deck turns on and starts playing. When the ending time arrives, the deck stops playing and turns off.
- 6 After you have finished using the timer, set TIMER on the deck to OFF.

#### Note

You can select Program Play in Step 2. Note, however, that programs eventually fade away when the standby status is off, and therefore if you set the time too far in the future, the program may be gone when the specified time arrives. If this has occurred, the deck enters normal play mode at the specified time and the tracks play in consecutive order.

## Falling Asleep to Music

You can let the deck turn off at the specified time, so you can sleep to the music.  
You can specify the time to be turned off by 30 minutes.

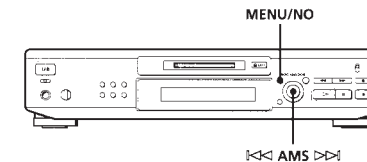

- 1 Press MENU/NO twice to display "Setup Menu".
- 2 Turn AMS to select "Setup 14", then press AMS.
- 3 Turn AMS to select the time.  
The minutes display changes as follows:  
30min ↔ 60min ↔ 90min ↔ 120min
- 4 Press AMS.
- 5 Turn AMS to select "Setup 15", then press AMS.
- 6 Turn AMS to select "Sleep On", then press AMS.  
"SLEEP" lights up in the display.
- 7 Press MENU/NO.

#### To change the time to turn off

Start over from Step 1 above.

#### To cancel the Sleep Timer Function

Select "Sleep Off" in Step 6 above, then press AMS.

## Notes on Editing

You can edit the recorded tracks after recording, using the following functions:

- Erase Function allows you to erase recorded tracks simply by specifying the corresponding track number.
- A-B Erase Function allows you to specify a portion within a track to erase it.
- Divide Function allows you to divide tracks at specified points so that you can quickly locate those points afterwards, using the AMS function.
- Combine Function allows you to combine two consecutive tracks into one.
- Move Function allows you to change the order of tracks by moving a specific track to a track position you want.
- Title Function allows you to create titles for your recorded MDs and tracks.

### If "Protected" alternates with "C11" in the display

The deck could not edit because the record-protect slot on the MD is open. Edit after closing the slot.

### When "TOC" and "TOC Writing" flash in the display

Do not move the deck or pull out the AC power cord. After editing, "TOC" lights continuously until you eject the MD or turn off the power. "TOC" and "TOC Writing" flash while the deck is updating the TOC. When the deck finishes updating the TOC, "TOC" goes off.

## Erasing Recordings (Erase Function)

Do the procedures below to erase following:

- A single track
- All tracks

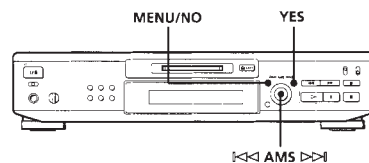

### Erasing a single track

You can erase a track simply by specifying the respective track number. When you erase a track, the total number of tracks on the MD decreases by one and all tracks following the erased one are renumbered. Since erasing merely updates the TOC, there is no need to record over material.

**Note** To avoid confusion when erasing multiple tracks, you should proceed in order of high to low track number to prevent the renumbering of tracks that have not been erased yet.

#### Example: Erasing B

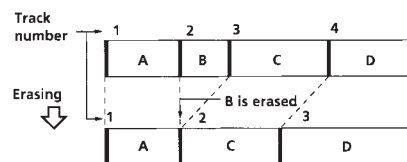

- 1 While the deck is stopped, playing, or pausing, press MENU/NO to display "Edit Menu".
- 2 Turn AMS until "Tr Erase ?" appears in the display.
- 3 Press AMS or YES. The display for erasing tracks appears and playback of the displayed track starts.
- 4 Turn AMS to select the track to be erased.

## Erasing all tracks on an MD

Erasing a recordable MD deletes the disc name, all recorded tracks, and titles.

- 1 While the deck is stopped, playing, or pausing, press MENU/NO to display "Edit Menu".
- 2 Turn AMS until "All Erase ?" appears in the display.
- 3 Press AMS or YES. "All Erase??" appears in the display and all tracks in the music calendar start flashing.
- 4 Press AMS or YES. When the disc name, all recorded tracks, and titles on the MD have been erased, "Complete!!" appears for a few seconds and the music calendar disappears.

### To cancel the Erase Function

Press MENU/NO or ■ to turn off the "All Erase ?" or "All Erase??" indication.

### **Note** You can undo the Erase Function

Use the Undo Function immediately after you erased the track (see page 37).

## 5 Press AMS or YES.

When the track selected in Step 4 has been erased, "Complete!!" appears for a few seconds and the total number of tracks in the music calendar decreases by one.

The track following the erased track begins playing. (If you erase the last track, the track preceding the erased track starts playing.)

## 6 Repeat Steps 1 to 5 to erase more tracks.

### To cancel the Erase Function

Press MENU/NO or ■.

### Note

If "Erase ???" appears in the display, the track was recorded or edited on another MD deck and is record-protected. If this indication appears, press AMS or YES to erase the track.



## Erasing a Part of a Track (A-B Erase Function)

You can specify a portion within a track and erase the portion with ease. It is convenient when erasing unnecessary sections after recording satellite broadcast or FM broadcast.

Example: Erasing a part of track A

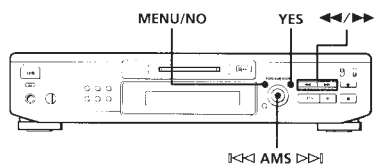
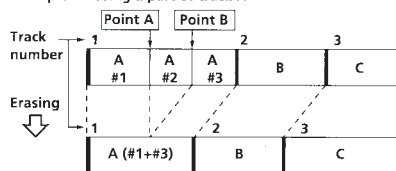

- 1 While the deck is stopped, playing, or pausing, press MENU/NO to display "Edit Menu".
- 2 Turn AMS until "A-B Erase?" appears in the display.
- 3 Press AMS or YES.
- 4 Turn AMS to select the number of the track, then press AMS or YES. "Rehearsal" and "Point A ok?" alternates in the display while the deck plays back the selected track from the beginning.

- 5 While monitoring the sound, turn AMS to find the starting point of the portion to be erased (point A). You can select the unit by which the starting point is shifted. Press the ◀◀ or ▶▶ button to select frame\*, second, or minute. For frame, the number of frames appears when you turn the AMS control; for second and minute, "s" or "m" flashes in the display. \* 1 frame is about 12 ms.

- 6 If the point A is still incorrect, repeat Step 5 until it is correct.
- 7 Press AMS or YES if the position is correct. "Point B set" appears in the display and playback for setting the end point of the portion to be erased (point B) starts.
- 8 Continue playback (or press ◀◀ or ▶▶) until the deck reaches point B, then press AMS or YES. "A-B Erase" and "Point B ok?" alternates in the display while the deck repeats a portion of a few seconds before point A and after point B successively.

- 9 Repeat Step 5 if point B is not correct.

- 10 Press AMS or YES when the position is correct. "Complete!!" appears for a few seconds and the portion between point A and B is erased.

### To cancel the A-B Erase Function

Press MENU/NO or ■.

### Note

If "Impossible" appears in the display, this means:  
 - You specified point B comes before point A. Point B should be specified after point A. The specified portion cannot be erased. This sometimes happens when you've edited the same track many times, and is due to a technical limitation of the MD system, not a mechanical error.

## Dividing Recorded Tracks (Divide Function)

With the Divide Function you can mark a track number at places that you want to randomly access afterwards. Use this function to add tracks to MDs recorded from an analog source (and therefore contain no track numbers), or to divide an existing track into multiple portions for locating positions in the middle of a track. When you divide a track, the total number of tracks on the MD increases by one and all tracks following the divided track are renumbered.

Example: Dividing track 2 to create a new track for C

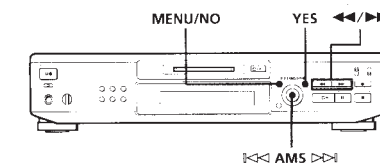
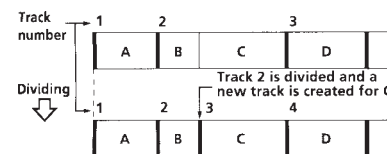

### Dividing a track after selecting the track

- 1 While the deck is stopped, playing, or pausing, press MENU/NO to display "Edit Menu".
- 2 Turn AMS until "Divide?" appears in the display, then press AMS or YES.
- 3 Turn AMS to select the track to be divided and press AMS or YES. "Rehearsal" appears in the display and the deck plays back the selected track from the beginning.

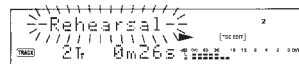

- 4 While monitoring the sound, turn AMS to find the point to divide the track. You can select the unit by which the starting point is shifted. Press the ◀◀ or ▶▶ button to select frame, second, or minute. For frame, the number of frames appears when you turn the AMS control; for second and minute, "s" or "m" flashes in the display.

- 5 Press AMS or YES when the position is correct. "Complete!!" appears for a few seconds and the newly created track begins playing. The new track will have no track title even if the original track was labeled. The total number of tracks in the music calendar increases by one.

### To cancel the Divide Function

Press MENU/NO or ■.

### You can undo the Divide Function

Use the Undo Function immediately after you divided the track (see page 37).

### You can divide a track while recording

Use the Track Marking Function (see page 13).

### Dividing a track after selecting the dividing point

- 1 While playing the MD, press AMS at the point where you want to create a new track. "Divide" and "Rehearsal" alternate in the display and playback continues from the position you selected.
- 2 To make fine adjustment on the dividing position, do Step 4 in "Dividing a track after selecting the track" on this page.
- 3 Press YES. "Complete!!" appears for a few seconds and the newly created track begins playing.

### To cancel the Divide Function

Press AMS, MENU/NO or ■.



## Combining Recorded Tracks (Combine Function)

Use the Combine Function to combine tracks on a recorded MD. The two tracks to be combined need not be consecutive and the latter track to be combined can be the track which comes before the former one in the track number order. This function is useful for combining several songs into a single medley, or several independently recorded portions into a single track. When you combine two tracks, the total number of tracks decreases by one and all tracks following the combined tracks are renumbered.

Example: Combining B and D

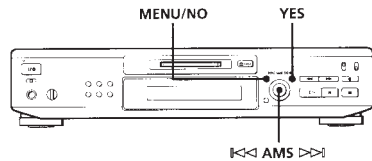
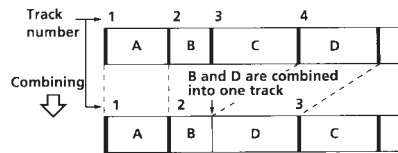

- 1 While the deck is stopped, playing, or pausing, press MENU/NO to display "Edit Menu".
- 2 Turn AMS until "Combine ?" appears in the display.
- 3 Press AMS or YES.

- 4 Turn AMS to select the first track of the two to be combined and press AMS or YES. The display for selecting the second track appears and the deck repeats the portion where the two tracks will join (i.e., the end of the first track and the beginning of the succeeding track).

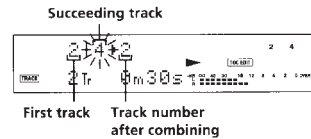

- 5 Turn AMS to select the second track of the two to be combined and press AMS or YES. "Complete!!" appears for a few seconds and the total number of tracks in the music calendar decreases by one. If both of the combined tracks have track titles, the title of the second track is erased.

### To cancel the Combine Function

Press MENU/NO or ■.

### You can undo the Combine Function

Use the Undo Function immediately after you combined the tracks (see page 37).

### Note

If "Impossible" appears in the display, the tracks cannot be combined. This sometimes happens when you've edited the same track many times, and is due to a technical limitation of the MD system, not a mechanical error.

## Moving Recorded Tracks (Move Function)

Use the Move Function to change the order of any track. After you move a track, the track numbers between the new and old track positions are automatically renumbered.

Example: Moving track C to track position 2

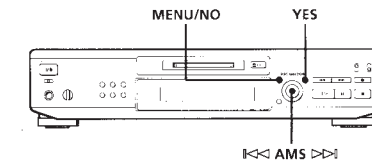
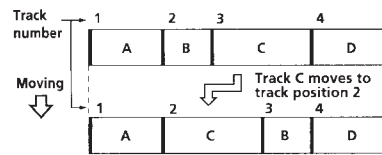

- 1 While the deck is stopped, playing, or pausing, press MENU/NO to display "Edit Menu".
- 2 Turn AMS until "Move ?" appears in the display.
- 3 Press AMS or YES.
- 4 Turn AMS to select the track to be moved and press AMS or YES.
- 5 Turn AMS until the new track position appears.

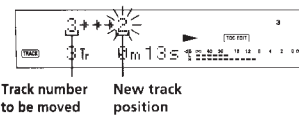

- 6 Press AMS or YES. "Complete!!" appears for a few seconds and the moved track begins playing back.

### To cancel the Move Function

Press MENU/NO or ■.

## Labeling Recordings (Title Function)

You can create titles for your recorded MDs and tracks. Titles — which may consist of uppercase and lowercase letters, numbers and symbols for a maximum of about 1,700 characters per disc — appear in the display during MD operation. You can also use the remote to label a track or an MD (see "Labeling tracks and MDs with the remote" on page 35).

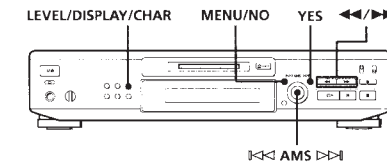

Use the following procedure to label a track or an MD. You can label a track while it is playing, pausing or recording. If the track is recording, be sure to finish labeling before the track ends. If the track ends before you've completed the labeling procedure, the characters already entered are not recorded and the track will remain unlabeled.

- 1 Press MENU/NO to display "Edit Menu".
- 2 Turn AMS until "Name ?" appears in the display and press AMS or YES. Skip this step while recording.
- 3 Turn AMS until "Nm In ?" appears in the display, then press AMS or YES.
- 4 Turn AMS to select "Disc" to label an MD, or to specify the track to label. While recording, go to Step 6.
- 5 Press AMS or YES. A flashing cursor appears in the display.

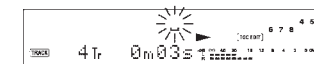

(Continued)

- 6 Press LEVEL/DISPLAY/CHAR to select the character type as follows:

To select	Press LEVEL/DISPLAY/CHAR repeatedly until
Uppercase letters	"A" appears in the display
Lowercase letters	"a" appears in the display
Numbers	"0" appears in the display



- 7 Turn AMS to select the character. The selected character flashes. Letters, numbers, and symbols appear in sequential order as you turn AMS. You can use the following symbols in titles:

! " # \$ % & ' ( ) \* + , - . / : ; < = > ? @ \_ `



You can press LEVEL/DISPLAY/CHAR to change the character type at any time during Step 7 (see Step 6).

- 8 Press AMS to enter the selected character. The cursor shifts rightward and waits for the input of the next character.



- 9 Repeat Steps 7 and 8 until you have entered the entire title.

**If you entered the wrong character**

Press ◀ or ▶ until the character to be corrected starts flashing, and repeat Steps 7 and 8 to enter the correct character.

**To erase a character**

Press ◀ or ▶ until the character to be erased starts flashing, then press CLEAR.

**To enter a space**

Press AMS while the cursor is flashing.

- 10 Press YES.

This completes the labeling procedure and the title appears in the display.

**To cancel labeling**

Press MENU/NO or ■.

**Note**

You cannot label a track or an MD while you are recording over an existing track.

**Copying a track or disc title**

You can copy a track or disc title to use it as a title of another track or the disc title within a disc. Note that you can do this operation by using the controls on the deck only.

- 1 Press MENU/NO to display "Edit Menu".
- 2 Turn AMS until "Name ?" appears in the display and press AMS or YES.
- 3 Turn AMS until "Nm Copy ?" appears in the display.
- 4 Press AMS or YES.

- 5 Turn AMS to select "Disc" to copy the disc title, or the track whose title you want to copy and press AMS or YES.

**If "No Name" appears in the display**

The disc or the track has no name.

- 6 Turn AMS to select "Disc" for disc title or to specify the track number to copy a title, and press AMS or YES. "Complete!!" appears for a few seconds to indicate that the copying operation is completed.

**If "Overwrite?" appears in the display**

The disc or track you selected in Step 6 above has a title. If you continue the title copying, press AMS or YES.

**To cancel title copying**

Press MENU/NO or ■.

**Labeling tracks and MDs with the remote**

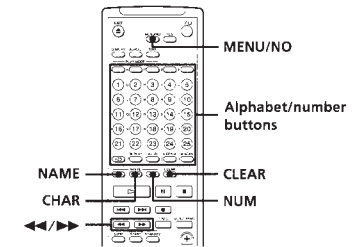

- 1 Press NAME repeatedly until a flashing cursor appears in the display, then do the following:

To label	Make sure that the deck is
A track	Playing, pausing, recording the track to be labeled, or stopped after locating the track to be labeled
An MD	Stopped with no track number appearing in the display

- 2 Select the character type as follows:

To select	Press
Uppercase letters	CHAR repeatedly until "Selected AB" appears in the display
Lowercase letters	CHAR repeatedly until "Selected ab" appears in the display
Numbers	NUM repeatedly until "Selected 12" appears in the display

- 3 Press an alphabet/number button to enter a character. After you enter a character, the cursor shifts rightward and waits for the input of the next character. You can change the character type at any time during Step 3 (see Step 2).

(Continued)

- Repeat Step 3 until you have entered the entire title.

**If you entered the wrong character**

Press ◀ or ▶ until the character to be corrected starts flashing.

Press CLEAR to erase the incorrect character, then enter the correct one.

- Press NAME again. This completes the labeling procedure and the title appears in the display.

**To cancel labeling**

Press MENU/NO or ■.

**Changing an existing title**

- Press NAME, then do the following:

To change	Make sure that the deck is
A track title	Playing, pausing the track whose title is to be changed, or stopped after locating the track whose title is to be changed
A disc name	Stopped with no track number appearing in the display

- Hold down CLEAR until the current title is erased.
- Enter the new title. Do Steps 6 to 9 of "Labeling Recordings" on page 34, or Steps 2 to 4 of "Labeling tracks and MDs with the remote" on page 35 and this page.
- Press NAME.

**Erasing a title on a disc (Name Erase)**

Use this function to erase a title on a disc.

- While the deck is stopped, playing, or pausing, press MENU/NO to display "Edit Menu".
- Turn AMS until "Name ?" appears in the display and press AMS or YES.

- Turn AMS until "Nm Erase ?" appears in the display and press AMS or YES.

- Turn AMS to select "Disc" to erase the disc title, or the track whose title you want to erase and press AMS or YES. "Complete!!" appears for a few seconds and the title is erased.

**To cancel Name Erase Function**

Press MENU/NO or ■.

**Erasing all titles on a disc (Name All Erase)**

Use this function to erase all titles on an MD simultaneously.

- While the deck is stopped, playing, or pausing, press MENU/NO to display "Edit Menu".
- Turn AMS until "Name ?" appears in the display and press AMS or YES.
- Turn AMS until "Nm AllErs?" appears in the display and press AMS or YES. "Nm AllErs?" appears in the display.
- Press AMS or YES. "Complete!!" appears for a few seconds and all titles are erased.

**To cancel the Name All Erase Function**

Press MENU/NO or ■.

 **You can undo the Name All Erase Function**  
See "Undoing the Last Edit" on page 37.

 **You can erase all recorded tracks and titles**  
See "Erasing all tracks on an MD" on page 29.

**Undoing the Last Edit (Undo Function)**

You can use the Undo Function to cancel the last edit and restore the contents of the MD to the condition that existed before editing was done. Note, however, that you cannot undo an edit if you do any of the following after the edit:

- Press the ● REC button on the deck.
- Press the ● button, the MUSIC SYNC button, or the CD SYNC STANDBY button on the remote.
- Update the TOC by turning off the power or ejecting the MD.
- Disconnect the AC power cord.

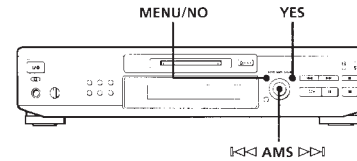

- With the deck stopped and no track number appearing in the display, press MENU/NO to display "Edit Menu".
- Turn AMS until "Undo ?" appears in the display. "Undo ?" does not appear if no editing has been done.
- Press AMS or YES.

One of the following messages appears in the display, depending on the type of editing to be undone:

Editing done:	Message:
Erasing a single track	
Erasing all tracks on an MD	"Erase Undo?"
Erasing a part of a track	
Dividing a track	"DivideUndo?"
Combining tracks	"CombinUndo?"
Moving a track	"Move Undo?"
Labeling a track or an MD	
Changing an existing title	"Name Undo?"
Erasing all titles on an MD	
Copying a title	

- Press AMS or YES again. "Complete!!" appears for a few seconds and the contents of the MD are restored to the condition that existed before the edit.

**To cancel the Undo Function**

Press MENU/NO or ■.

## SECTION 3 DISASSEMBLY

**Note:** Follow the disassembly procedure in the numerical order given.

### 3-1. CASE AND FRONT PANEL

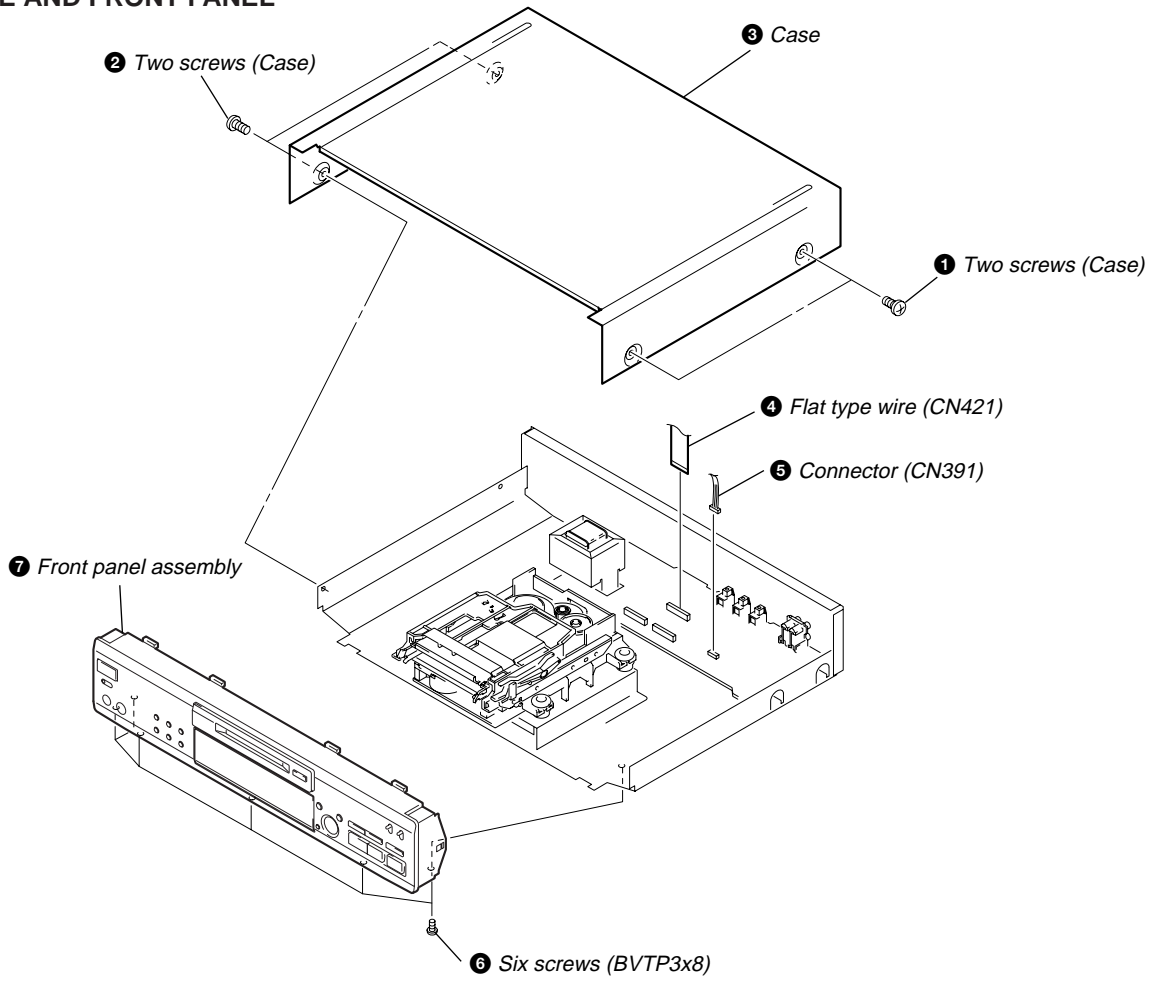

### 3-2. SLIDER (CAM)

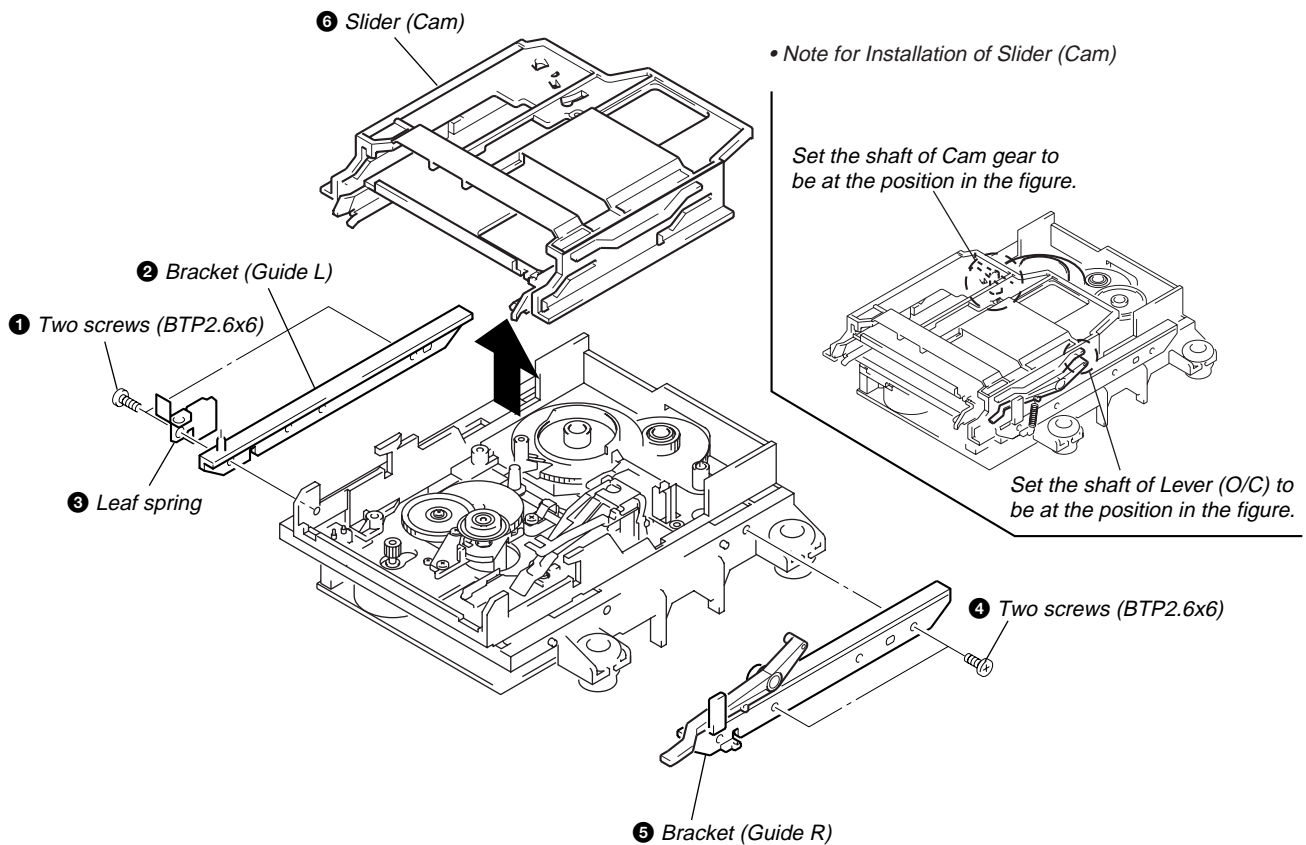

### 3-3. BASE UNIT (MBU-5A) AND BD BOARD

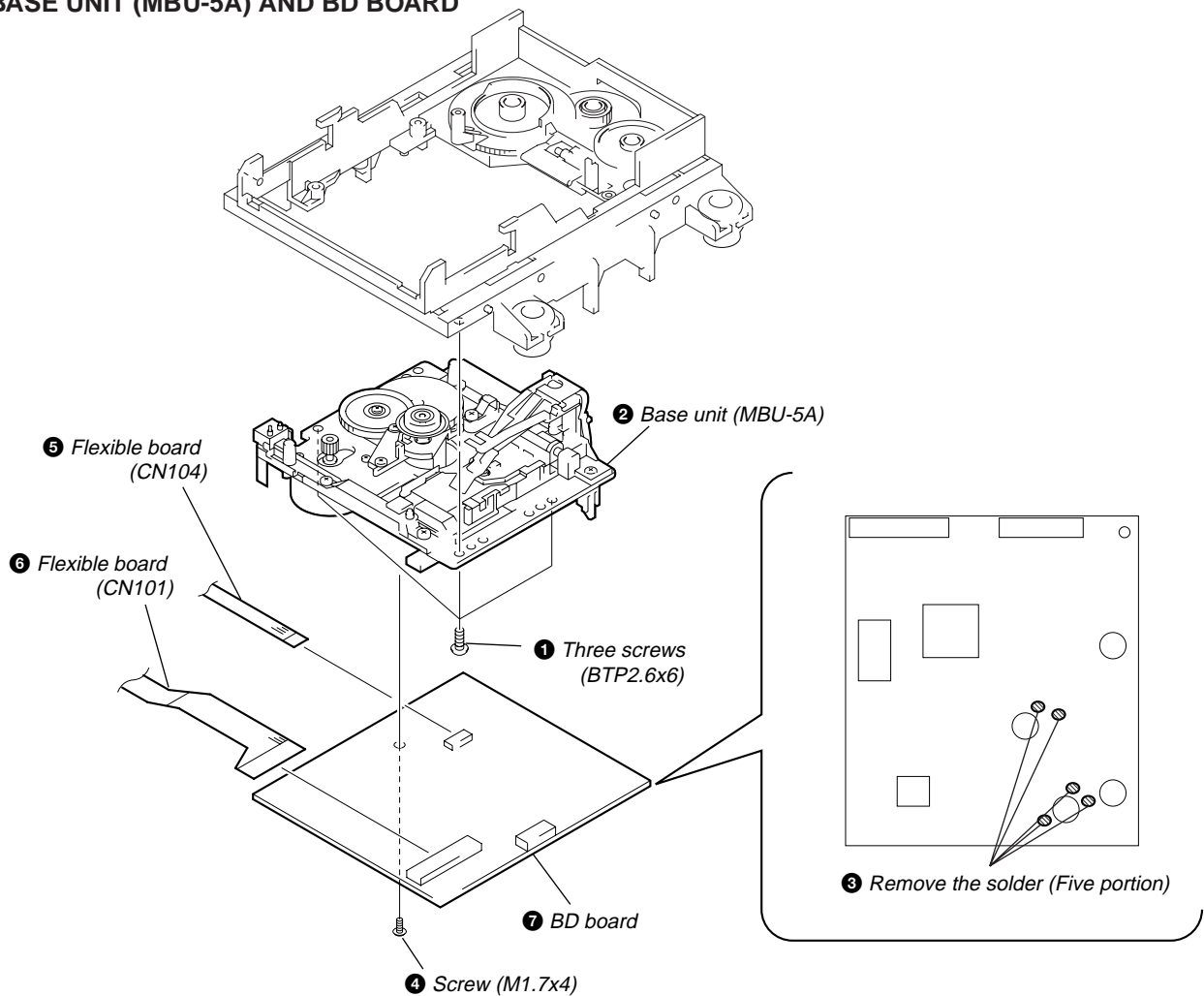

### 3-4. SW BOARD AND LOADING MOTOR (M103)

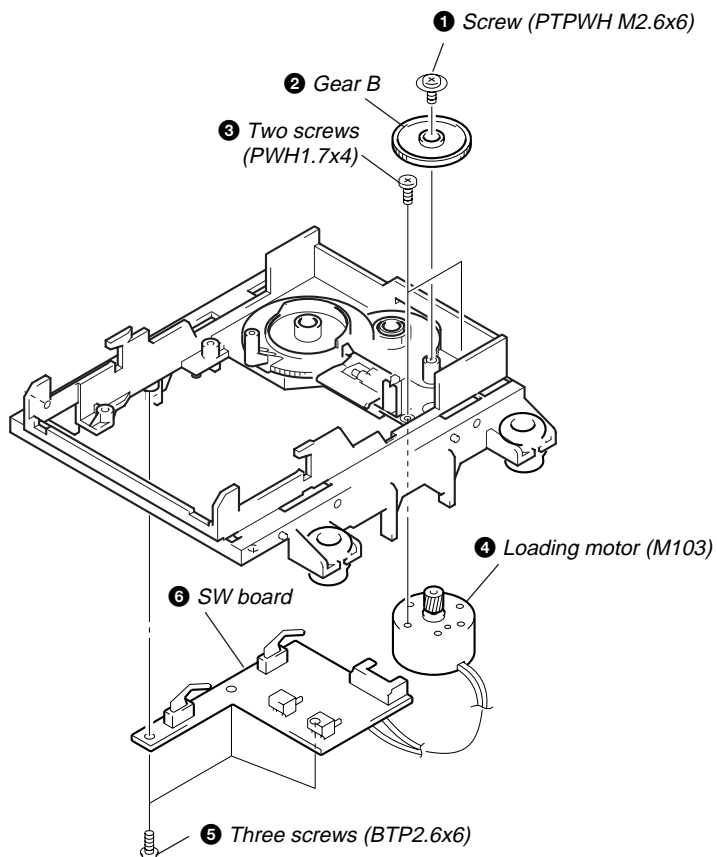

# SECTION 4 TEST MODE

## 4-1. PRECAUTIONS FOR USE OF TEST MODE

- As loading related operations will be performed regardless of the test mode operations being performed, be sure to check that the disc is stopped before setting and removing it.  
Even if the **[EJECT]** button is pressed while the disc is rotating during continuous playback, continuous recording, etc., the disc will not stop rotating.  
Therefore, it will be ejected while rotating.  
Be sure to press the **[EJECT]** button after pressing the **[MENU/NO]** button and the rotation of disc is stopped.

### 4-1-1. Recording laser emission mode and operating buttons

- Continuous recording mode (CREC MODE)
- Laser power check mode (LDPWR CHECK)
- Laser power adjustment mode (LDPWR ADJUST)
- Traverse (MO) check (EF MO CHECK)
- Traverse (MO) adjustment (EF MO ADJUST)
- When pressing the **[●REC]** button.

## 4-2. SETTING THE TEST MODE

The following are two methods of entering the test mode.

**Procedure 1:** While pressing the **[AMS]** knob and **[■]** button, connect the power plug to an outlet, and release the **[AMS]** knob and **[■]** button.  
When the test mode is set, “[Check]” will be displayed. Rotating the **[AMS]** knob switches between the following four groups;

...←→ Check ←→ Adjust ←→ Service ←→ Develop ←→ ...

**Procedure 2:** While pressing the **[AMS]** knob, connect the power plug to the outlet and release the **[AMS]** knob.

When the test mode is set, “TEMP CHECK” will be displayed. By setting the test mode using this method, only the “Check” group of method 1 can be executed.

## 4-3. EXITING THE TEST MODE

Press the **[REPEAT]** button. The disc is ejected when loaded, and “Standby” display blinks, and the STANDBY state is set.

## 4-4. BASIC OPERATIONS OF THE TEST MODE

All operations are performed using the **[AMS]** knob, **[YES]** button, and **[MENU/NO]** button.

The functions of these buttons are as follows.

Function name	Function
AMS knob	Changes parameters and modes
YES button	Proceeds onto the next step. Finalizes input.
MENU/NO button	Returns to previous step. Stops operations.

#### 4-5. SELECTING THE TEST MODE

There are 31 types of test modes as shown below. The groups can be switched by rotating the [AMS] knob. After selecting the group to be used, press the [YES] button. After setting a certain group, rotating the [AMS] knob switches between these modes. Refer to “Group” in the table for details selected.

All items used for servicing can be treated using group S. So be carefully not to enter other groups by mistake.

Display	No	Contents	Mark	Group (*)
TEMP CHECK	C01	Temperature compensation offset check		C S
LDPWR CHECK	C02	Laser power check		C S
EF MO CHECK	C03	Traverse (MO) check		C S
EF CD CHECK	C04	Traverse (CD) check		C S
FBIAS CHECK	C05	Focus bias check		C S
S curve CHECK	C06	S letter check	(X)	C
VERIFY MODE	C07	Non-volatile memory check	(X)	C
DETRK CHECK	C08	Detrack check	(X)	C
TEMP ADJUS	C09	Temperature compensation offset adjustment		A S
LDPWR ADJUS	C10	Laser power adjustment		A S
EF MO ADJUS	C11	Traverse (MO) adjustment		A S
EF CD ADJUS	C12	Traverse (CD) adjustment		A S
FBIAS ADJUS	C13	Focus bias adjustment		A S
EEP MODE	C14	Non-volatile memory control	(X) (!)	D
MANUAL CMD	C15	Command transmission	(X)	D
SVDATA READ	C16	Status display	(X)	D
ERR DP MODE	C17	Error history display, clear		S
SLES MOVE	C18	Sled check	(X)	D
ACCESS MODE	C19	Access check	(X)	D
0920 CHECK	C20	Outermost circumference check	(X)	D
HEAD ADJUST	C21	Head position check	(X)	D
CPLAY2 MODE	C22	Same functions as CPLAY MODE	(X)	D
CREC2 MODE	C23	Same functions as CREC MODE	(X)	D
ADJ CLEAR	C24	Initialization of non-volatile memory of adjustment value		A S
AG Set (MO)	C25	Auto gain output level adjustment (MO)		A S
AG Set (CD)	C26	Auto gain output level adjustment (CD)		A S
Iop Read	C27	IOP data display		C S
Iop Write	C28	IOP data write		A S
JE520 @.@.@	C29	Microprocessing version display		C S
CPLAY MODE	C30	Continuous play mode		C A S D
CREC MODE	C31	Continuous recording mode		C A S D

Group (\*)  
 C: Check      A: Adjust  
 S: Service    D: Develop

- For details of each adjustment mode, refer to “5. Electrical Adjustments”.
- For details of “ERR DP MODE”, refer to “Self-Diagnosis Function” on page 2.
- If a different mode has been selected by mistake, press the [MENU/NO] button to exit that mode.
- Modes with (X) in the Mark column are not used for servicing and therefore are not described in detail. If these modes are set accidentally, press the [MENU/NO] button to exit the mode immediately. Be especially careful not to set the modes with (!) as they will overwrite the non-volatile memory and reset it, and as a result, the unit will not operate normally.

#### 4-5-1. Operating the Continuous Playback Mode

##### 1. Entering the continuous playback mode

- ① Set the disc in the unit. (Whichever recordable discs or discs for playback only are available.)
- ② Rotate the [AMS] knob and display "CPLAY MODE" (C30).
- ③ Press the [YES] button to change the display to "CPLAY MID".
- ④ When access completes, the display changes to "C1 = [ ] AD = [ ]".

**Note :** The numbers "[ ]" displayed show you error rates and ADER.

##### 2. Changing the parts to be played back

- ① Press the [YES] button during continuous playback to change the display as below.

"CPLAY MID" → "CPLAY OUT" → "CPLAY IN" →



When pressed another time, the parts to be played back can be moved.

- ② When access completes, the display changes to "C1 = [ ] AD = [ ]".

**Note :** The numbers "[ ]" displayed show you error rates and ADER.

##### 3. Ending the continuous playback mode

- ① Press the [MENU/NO] button. The display will change to "CPLAY MODE".
- ② Press the [EJECT] button to remove the disc.

**Note :** The playback start addresses for IN, MID, and OUT are as follows.

IN 40h cluster  
MID 300h cluster  
OUT 700h cluster

#### 4-5-2. Operating the Continuous Recording Mode (Use only when performing self-recording/playback check.)

##### 1. Entering the continuous recording mode

- ① Set a recordable disc in the unit.
- ② Rotate the [AMS] knob and display "CREC MODE".
- ③ Press the [YES] button to change the display to "CREC MID" (C31).
- ④ When access completes, the display changes to "CREC [ ]" and [REC] lights up.

**Note :** The numbers "[ ]" displayed shows you the recording position addresses.

##### 2. Changing the parts to be recorded

- ① When the [YES] button is pressed during continuous recording, the display changes as below.

"CPLAY MID" → "CPLAY OUT" → "CPLAY IN" →



When pressed another time, the parts to be recorded can be changed. [REC] goes off.

- ② When access completes, the display changes to "CREC [ ]" and [REC] lights up.

**Note :** The numbers "[ ]" displayed shows you the recording position addresses.

##### 3. Ending the continuous recording mode

- ① Press the [MENU/NO] button. The display changes to "CREC MODE" and [REC] goes off.
- ② Press the [EJECT] button to remove the disc.

**Note 1 :** The recording start addresses for IN, MID, and OUT are as follows.

IN 40h cluster  
MID 300h cluster  
OUT 700h cluster

**Note 2 :** The [MENU/NO] button can be used to stop recording anytime.

**Note 3 :** Do not perform continuous recording for long periods of time above 5 minutes.

**Note 4 :** During continuous recording, be careful not to apply vibration.

#### 4-5-3. Non-Volatile Memory Mode (EEP MODE)

This mode reads and writes the contents of the non-volatile memory.

It is not used in servicing. If set accidentally, press the [MENU/NO] button immediately to exit it.



## 4-6. FUNCTIONS OF OTHER BUTTONS

Function	Contents
▷	Sets continuous playback when pressed in the STOP state. When pressed during continuous playback, the tracking servo turns ON/OFF.
■	Stops continuous playback and continuous recording.
▶▶	The sled moves to the outer circumference only when this is pressed.
◀◀	The sled moves to the inner circumference only when this is pressed.
● REC	Turns recording ON/OFF when pressed during continuous playback.
SCROLL	Switches between the pit and groove modes when pressed.
PLAY MODE	Switches the spindle servo mode (CLVS ↔ CLV A).
LEVEL/DISPLAY/CHAR	Switches the displayed contents each time the button is pressed
⊞ EJECT	Ejects the disc
REPEAT	Exits the test mode

## 4-7. TEST MODE DISPLAYS

Each time the [LEVEL/DISPLAY/CHAR] button is pressed, the display changes in the following order.

### 1. Mode display

Displays “TEMP ADJUST”, “CPLAYMODE”, etc.

### 2. Error rate display

Displays the error rate in the following way.

C = □□□□ AD = □□

C = Indicates the C1 error.

AD = Indicates ADER.

### 3. Address display

The address is displayed as follows. (MO:recordable disc, CD:playback only disc)

Pressing the [SCROLL] button switches between the group display and bit display.

h = □□□□ s = □□□□ (MO pit and CD)

h = □□□□ a = □□□□ (MO groove)

h = Indicates the header address.

s = Indicates the SUBQ address.

a = Indicates the ADIP address.

**Note:** “-” is displayed when servo is not imposed.

### 4. Auto gain display (Not used in servicing)

The auto gain is displayed as follows.

AG = □□ / □□ [□□

### 5. Detrack check display (Not used in servicing)

The detrack is displayed as follows.

ADR = □□□□□□□

### 6. IVR display (Not used in servicing)

The IVR is displayed as follows.

[□□][□□][□□

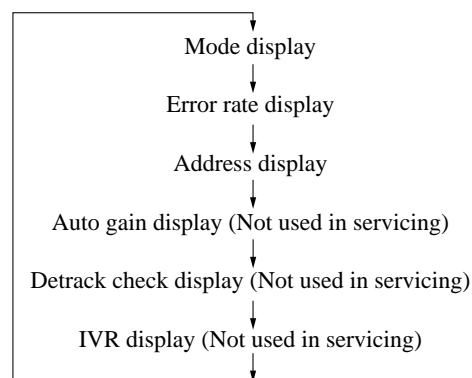

## MEANINGS OF OTHER DISPLAYS

Display	Contents	
	When Lit	When Off
▷	During continuous playback (CLV: ON)	STOP (CLV: OFF)
	Tracking servo OFF	Tracking servo ON
REC	Recording mode ON	Recording mode OFF
-SYNC	CLV low speed mode	CLV normal mode
A.SPACE	ABCD adjustment completed	
OVER	Tracking offset cancel ON	Tracking offset cancel OFF
REPEAT	Tracking auto gain OK	
A-B	Focus auto gain OK	
TRACK	Pit	Groove
DISC	High reflection	Low reflection
SLEEP	CLV-S	CLV-A
MONO	CLV LOCK	CLV UNLOCK

## SECTION 5 ELECTRICAL ADJUSTMENTS

### 5-1. PARTS REPLACEMENT AND ADJUSTMENT

- Check and adjust the MDM and MBU as follows.  
The procedure changes according to the part replaced

- Abbreviation  
OP : Optical pick-up  
OWH: Overwrite head

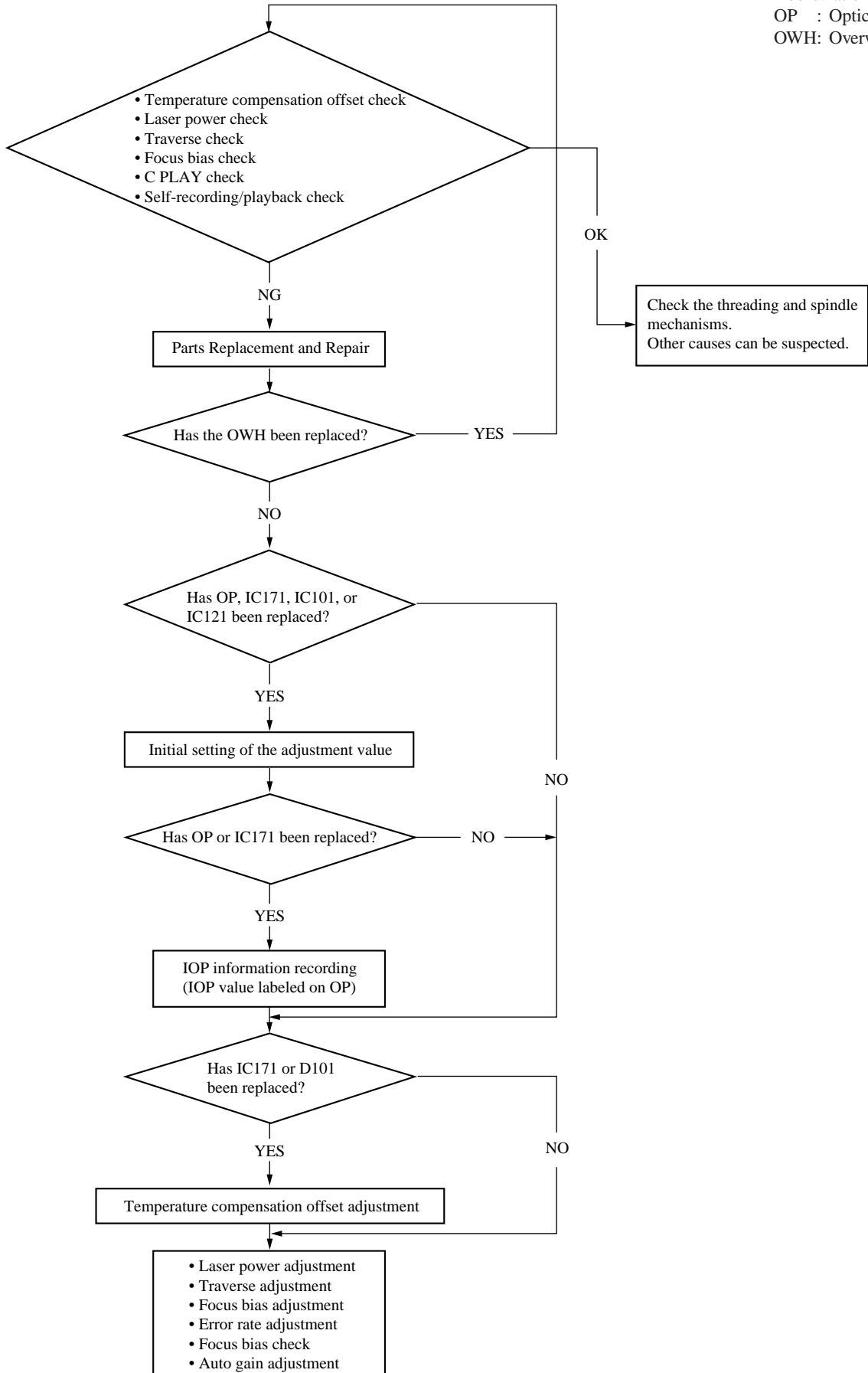

## 5-2. PRECAUTIONS FOR CHECKING LASER DIODE EMISSION

To check the emission of the laser diode during adjustments, never view directly from the top as this may lose your eye-sight.

## 5-3. PRECAUTIONS FOR USE OF OPTICAL PICK-UP (KMS-260A)

As the laser diode in the optical pick-up is easily damaged by static electricity, solder the laser tap of the flexible board when using it. Before disconnecting the connector, desolder first. Before connecting the connector, be careful not to remove the solder. Also take adequate measures to prevent damage by static electricity. Handle the flexible board with care as it breaks easily.

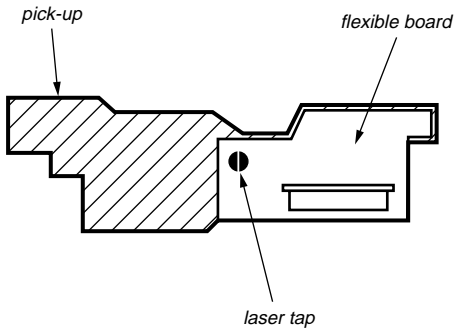

**Optical pick-up flexible board**

## 5-4. PRECAUTIONS FOR ADJUSTMENTS

1) When replacing the following parts, perform the adjustments and checks with ○ in the order shown in the following table.

	Optical Pick-up	BD Board			
		IC171	D101	IC101, IC121	IC192
1. Initial setting of adjustment value	○	○	×	○	×
2. Recording of IOP information (Value written in the pick-up)	○	○	×	×	×
3. Temperature compensation offset adjustment	×	○	○	×	×
4. Laser power adjustment	○	○	×	○	○
5. Traverse adjustment	○	○	×	○	×
6. Focus bias adjustment	○	○	×	○	×
7. Error rate check	○	○	×	○	×
8. Auto gain output level adjustment	○	○	×	○	×

- 2) Set the test mode when performing adjustments.  
After completing the adjustments, exit the test mode.  
Perform the adjustments and checks in "group S" of the test mode.
- 3) Perform the adjustments to be needed in the order shown.

- 4) Use the following tools and measuring devices.
  - Check Disc (MD) TDYS-1 (Parts No. 4-963-646-01)
  - TEST DISK (MDW-74/AU-1) (Parts No. 8-892-341-41)
  - Laser power meter LPM-8001 (Parts No. J-2501-046-A)
or
  - MD Laser power meter 8010S (Parts No. J-2501-145-A)
  - Oscilloscope (Measure after performing CAL of prove.)
  - Digital voltmeter
  - Thermometer
  - Jig for checking BD board waveform (Parts No. : J-2501-149-A)
- 5) When observing several signals on the oscilloscope, etc., make sure that VC and ground do not connect inside the oscilloscope. (VC and ground will become short-circuited.)
- 6) Using the above jig enables the waveform to be checked without the need to solder. (Refer to Servicing Note on page 6.)
- 7) As the disc used will affect the adjustment results, make sure that no dusts nor fingerprints are attached to it.

## 5-5. CREATING CONTINUOUSLY RECORDED DISC

\* This disc is used in focus bias adjustment and error rate check.

The following describes how to create a continuous recording disc.

1. Insert a disc (blank disc) commercially available.
2. Rotate the **[AMS]** knob and display "CREC MODE". (C31)
3. Press the **[YES]** button again to display "CREC MID".  
Display "CREC (0300)" and start to recording.
4. Complete recording within 5 minutes.
5. Press the **[MENU/NO]** button and stop recording .
6. Press the **[EJECT]** button and remove the disc.

The above has been how to create a continuous recorded data for the focus bias adjustment and error rate check.

### Note :

- Be careful not to apply vibration during continuous recording.

## 5-6. CHECKS PRIOR TO REPAIRS

These checks are performed before replacing parts according to “approximate specifications” to determine the faulty locations. For details, refer to “Checks Prior to Parts Replacement and Adjustments” (See page 8).

### 5-6-1. Temperature Compensation Offset Check

When performing adjustments, set the internal temperature and room temperature to 22 to 28 C.

#### Checking Procedure:

1. Rotate the **[AMS]** knob to display “TEMP CHECK”.
2. Press the **[YES]** button.
3. “T=@@ (##) [OK]” should be displayed. If “T=@@ (##) [NG]” is displayed, it means that the results are bad.  
(@@ indicates the current value set, and ## indicates the value written in the non-volatile memory.)

### 5-6-2. Laser Power Check

Before checking, check the IOP value of the optical pick-up. (Refer to 5-8. Recording and Displaying IOP Information.)

#### Connection :

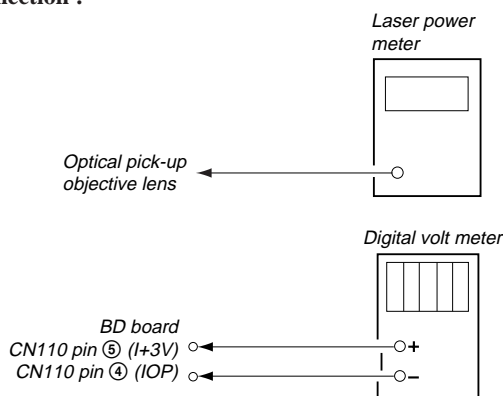

#### Checking Procedure:

1. Set the laser power meter on the objective lens of the optical pick-up. (When it cannot be set properly, press the **[◀▶]** button or **[▶▶]** button to move the optical pick-up.)  
Connect the digital volt meter to CN110 pin ⑤ (I+3V) and CN110 pin ④ (IOP).
2. Then, rotate the **[AMS]** knob and display “LDPWR CHECK” (C02).
3. Press the **[YES]** button once and display “LD 0.9 mW \$ [ ]”.  
Check that the reading of the laser power meter become 0.84 to 0.92 mW.
4. Press the **[YES]** button once more and display “LD 7.0 mW \$ [ ]”.  
Check that the reading of the laser power meter and digital volt meter satisfy the specified value.

#### Specified Value :

Laser power meter reading :  $7.0 \pm 0.2$  mW

Digital voltmeter reading : Optical pick-up displayed value  $\pm 10\%$

(Optical pick-up label)

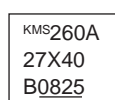

(For details of the method for checking this value, refer to “5-8. Recording and Displaying IOP Information”.)

$I_{op} = 82.5$  mA in this case

$I_{op}$  (mA) = Digital voltmeter reading (mV)/1 ( $\Omega$ )

5. Press the **[MENU/NO]** button and display “LDPWR CHECK” and stop the laser emission.  
(The **[MENU/NO]** button is effective at all times to stop the laser emission.)

**Note 1:** After step 4, each time the **[YES]** button is pressed, the display will be switched between “LD 0.7 mW \$ [ ]”, “LD 6.2 mW \$ [ ]”, and “LD Wp ホセイ \$ [ ]”. Nothing needs to be performed here.

### 5-6-3. Traverse Check

#### Connection :

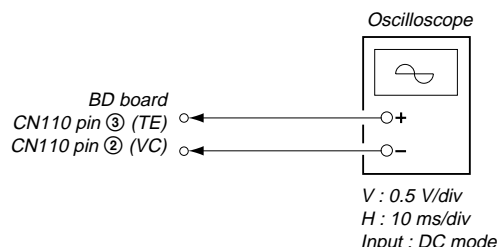

#### Checking Procedure:

1. Connect an oscilloscope to CN110 pin ③ (TE) and CN110 pin ② (VC) of the BD board.
2. Load a disc (any available on the market). (Refer to Note 1.)
3. Press the **[▶▶]** button and move the optical pick-up outside the pit.
4. Rotate the **[AMS]** knob and display “EF MO CHECK”(C03).
5. Press the **[YES]** button and display “EFB = [ ] MO-R”.  
(Laser power READ power/Focus servo ON/tracking servo OFF/spindle (S) servo ON)
6. Observe the waveform of the oscilloscope, and check that the specified value is satisfied. Do not rotate the **[AMS]** knob.  
(Read power traverse checking)

(Traverse Waveform)

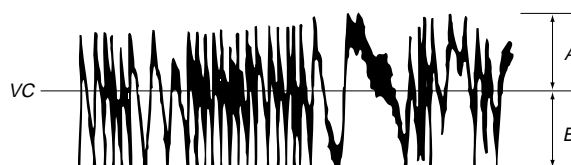

Specified value : Below 10% offset value

$$\text{Offset value (\%)} = \frac{A - B}{2(A + B)} \times 100$$

7. Press the **[YES]** button and display “EFB = [ ] MO-W”.
8. Observe the waveform of the oscilloscope, and check that the specified value is satisfied. Do not rotate the **[AMS]** knob.  
(Write power traverse checking)

(Traverse Waveform)

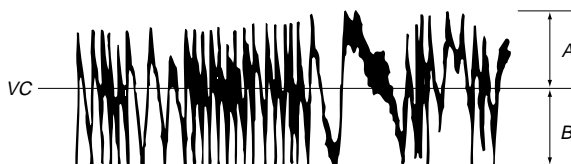

Specified value : Below 10% offset value

$$\text{Offset value (\%)} = \frac{A - B}{2(A + B)} \times 100$$

9. Press the **[YES]** button display “EFB = [ ] MO-P”.  
Then, the optical pick-up moves to the pit area automatically and servo is imposed.

10. Observe the waveform of the oscilloscope, and check that the specified value is satisfied. Do not rotate the **[AMS]** knob.

(Traverse Waveform)

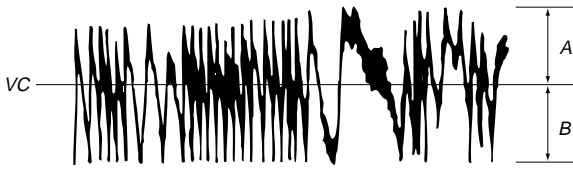

Specified value : Below 10% offset value

$$\text{Offset value (\%)} = \frac{|A - B|}{2(A + B)} \times 100$$

11. Press the **[YES]** button display “EF MO CHECK”  
The disc stops rotating automatically.
12. Press the **[EJECT]** button and remove the disc.
13. Load the check disc (MD) TDYS-1.
14. Rotate the **[AMS]** knob and display “EF CD CHECK” (C04).
15. Press the **[YES]** button and display “EFB =  $\square\square$  CD”. Servo is imposed automatically.
16. Observe the waveform of the oscilloscope, and check that the specified value is satisfied. Do not rotate the **[AMS]** knob.

(Traverse Waveform)

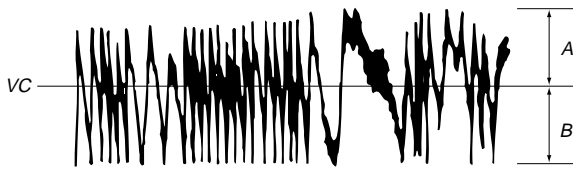

Specified value : Below 10% offset value

$$\text{Offset value (\%)} = \frac{|A - B|}{2(A + B)} \times 100$$

17. Press the **[YES]** button and display “EF CD CHECK”.
18. Press the **[EJECT]** button and remove the check disc (MD) TDYS-1.

**Note 1 :** MO reading data will be erased during if a recorded disc is used in this adjustment.

**Note 2 :** If the traverse waveform is not clear, connect the oscilloscope as shown in the following figure so that it can be seen more clearly.

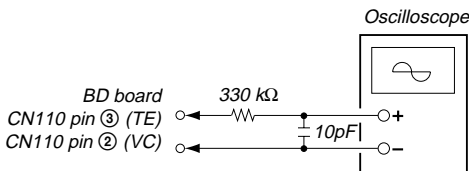

#### 5-6-4. Focus Bias Check

Change the focus bias and check the focus tolerance amount.

**Checking Procedure :**

1. Load a test disk (MDW-74/AU-1).
2. Rotate the **[AMS]** knob and display “CPLAY MODE” (C29).
3. Press the **[YES]** button twice and display “CPLAY MID”.
4. Press the **[MENU/NO]** button when “C =  $\square\square\square$  AD =  $\square$ ” is displayed.
5. Rotate the **[AMS]** knob and display “FBIAS CHECK” (C05).
6. Press the **[YES]** button and display “ $\square\square\square/\square$  c =  $\square$ ”.  
The first four digits indicate the C1 error rate, the two digits after [/] indicate ADER, and the 2 digits after [c =] indicate the focus bias value.  
Check that the C1 error is below 220 and ADER is below 2.
7. Press the **[YES]** button and display “ $\square\square\square/\square$  b =  $\square$ ”.  
Check that the C1 error is below 220 and ADER is below 2.
8. Press the **[YES]** button and display “ $\square\square\square/\square$  a =  $\square$ ”.  
Check that the C1 error is below 220 and ADER is below 2.
9. Press the **[MENU/NO]** button, next press the **[EJECT]** button, and remove the test disc.

#### 5-6-5. C PLAY Checking

**MO Error Rate Check**

**Checking Procedure :**

1. Load a test disk (MDW-74/AU-1).
2. Rotate the **[AMS]** knob and display “CPLAY MODE” (C29).
3. Press the **[YES]** button and display “CPLAY MID”.
4. The display changes to “C =  $\square\square\square$  AD =  $\square$ ”.
5. If the C1 error rate is below 80, check that ADER is below 2.
6. Press the **[MENU/NO]** button, stop playback, press the **[EJECT]** button, and test disc.

**CD Error Rate Check**

**Checking Procedure :**

1. Load a check disc (MD) TDYS-1.
2. Rotate the **[AMS]** knob and display “CPLAY MODE” (C29).
3. Press the **[YES]** button twice and display “CPLAY MID”.
4. The display changes to “C =  $\square\square\square$  AD =  $\square$ ”.
5. Check that the C1 error rate is below 50.
6. Press the **[MENU/NO]** button, stop playback, press the **[EJECT]** button, and the test disc.

#### 5-6-6. Self-Recording/playback Check

Prepare a continuous recording disc using the unit to be repaired and check the error rate.

**Checking Procedure :**

1. Insert a recordable disc (blank disc) into the unit.
2. Rotate the **[AMS]** knob to display “CREC MODE” (C31).
3. Press the **[YES]** button to display the “CREC MID”.
4. When recording starts, “**REC**” is displayed, this becomes “CREC @ @ @ @” (@ @ @ @ is the address), and recording starts.
5. About 1 minute later, press the **[MENU/NO]** button to stop continuous recording.
6. Rotate the **[AMS]** knob to display “C PLAY MODE”.
7. Press the **[YES]** button to display “C PLAY MID”.
8. “C =  $\square\square\square$  AD =  $\square$ ” will be displayed.
9. Check that the C1 error becomes below 80 and the AD error below 2.
10. Press the **[MENU/NO]** button to stop playback, and press the **[EJECT]** button and remove the disc.

## 5-7. INITIAL SETTING OF ADJUSTMENT VALUE

### Note:

Mode which sets the adjustment results recorded in the non-volatile memory to the initial setting value. However the results of the temperature compensation offset adjustment will not change to the initial setting value.

If initial setting is performed, perform all adjustments again excluding the temperature compensation offset adjustment.

For details of the initial setting, refer to “5-4. Precautions on Adjustments” and execute the initial setting before the adjustment as required.

### Setting Procedure :

1. Rotate the [AMS] knob to display “ADJ CLEAR (C24)”.
2. Press the [YES] button. “Complete!” will be displayed momentarily and initial setting will be executed, after which “ADJ CLEAR” will be displayed.

## 5-8. RECORDING AND DISPLAYING THE IOP INFORMATION

The IOP data can be recorded in the non-volatile memory. The IOP value on the label of the optical pickup and the IOP value after the adjustment will be recorded. Recording these data eliminates the need to read the label on the optical pick-up.

### Recording Procedure :

1. While pressing the [AMS] knob and [ ] button, connect the power plug to the outlet, and release the [AMS] knob and [ ] button.
2. Rotate the [AMS] knob to display “[Service]”, and press the [YES] button.
3. Rotate the [AMS] knob to display “Iop.Write” (C28), and press the [YES] button.
4. The display becomes Ref=@@.@ (@ is an arbitrary number) and the numbers which can be changed will blink.
5. Input the IOP value written on the optical pick-up.  
To select the number : Rotate the [AMS] knob.  
To select the digit : Press the [AMS] knob
6. When the [YES] button is pressed, the display becomes “Measu=@@.@” (@ is an arbitrary number).
7. As the adjustment results are recorded for the 6 value. Leave it as it is and press the [YES] button.
8. “Complete!” will be displayed momentarily. The value will be recorded in the non-volatile memory and the display will become “Iop Write”.

### Display Procedure :

1. Rotate the [AMS] knob to display “Iop.Read” .
2. “@@.@/##.##” is displayed and the recorded contents are displayed.  
@@.@ indicates the Iop value labeled on the pick-up.  
##.## indicates the Iop value after adjustment
3. To end, press the [AMS] button or [MENU/NO] button to display “Iop Read”.

## 5-9. TEMPERATURE COMPENSATION OFFSET ADJUSTMENT

Save the temperature data at that time in the non-volatile memory as 25 °C reference data.

### Note :

1. Usually, do not perform this adjustment.
2. Perform this adjustment in an ambient temperature of 22 °C to 28 °C. Perform it immediately after the power is turned on when the internal temperature of the unit is the same as the ambient temperature of 22 °C to 28 °C.
3. When D101 has been replaced, perform this adjustment after the temperature of this part has become the ambient temperature.

### Adjusting Procedure :

1. Rotate the [AMS] knob and display “TEMP ADJUS”.
2. Press the [YES] button and select the “TEMP ADJUS” mode.
3. “TEMP = [ ] [OK]” and the current temperature data will be displayed.
4. To save the data, press the [YES] button.  
When not saving the data, press the [MENU/NO] button.
5. When the [YES] button is pressed, “TEMP = [ ] SAVE” will be displayed and turned back to “TEMP ADJUS” display then.  
When the [MENU/NO] button is pressed, “TEMP ADJUS” will be displayed immediately.

### Specified Value :

The “TEMP = [ ]” should be within “E0 - EF”, “F0 - FF”, “00 - 0F”, “10 - 1F” and “20 - 2F”.

## 5-10. LASER POWER ADJUSTMENT

Check the IOP value of the optical pickup before adjustments. (Refer to 5-8. Recording and Displaying IOP Information.)

### Connection :

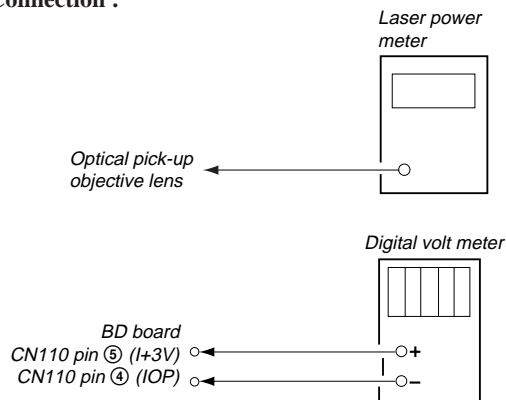

### Adjusting Procedure :

1. Set the laser power meter on the objective lens of the optical pick-up. (When it cannot be set properly, press the [◀] button or [▶] button to move the optical pick-up.)  
Connect the digital volt meter to CN110 pin ⑤ (+3V) and CN110 pin ④ (IOP).
2. Rotate the [AMS] knob and display “LDPWR ADJUS” (C10). (Laser power : For adjustment)
3. Press the [YES] button once and display “LD 0.9 mW \$ [ ]”.
4. Rotate the [AMS] knob so that the reading of the laser power meter becomes 0.85 to 0.91 mW. Press the [YES] button after setting the range knob of the laser power meter, and save the adjustment results. (“LD SAVE \$ [ ]” will be displayed for a moment.)
5. Then “LD 7.0 mW \$ [ ]” will be displayed.
6. Rotate the [AMS] knob so that the reading of the laser power meter becomes 6.9 to 7.1 mW, press the [YES] button and save it.

**Note :** Do not perform the emission with 7.0 mW more than 15 seconds continuously.



7. Then, rotate the **[AMS]** knob and display “LDPWR CHECK” (C02).
8. Press the **[YES]** button once and display “LD 0.9 mW \$  $\square\square$ ”. Check that the reading of the laser power meter become 0.85 to 0.91 mW.
9. Press the **[YES]** button once more and display “LD 7.0 mW \$  $\square\square$ ”. Check that the reading the laser power meter and digital volt meter satisfy the specified value.  
Note down the digital voltmeter reading value.

#### Specified Value :

Laser power meter reading :  $7.0 \pm 0.1$  mW

Digital voltmeter reading : Optical pick-up displayed value  $\pm 10\%$

(Optical pick-up label)

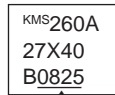

(For details of the method for checking this value, refer to “5-8. Recording and Displaying IOP Information”.)

$I_{op} = 82.5$  mA in this case  
 $I_{op}$  (mA) = Digital voltmeter reading (mV)/1 ( $\Omega$ )

10. Press the **[MENU/NO]** button and display “LDPWR CHECK” and stop the laser emission.  
(The **[MENU/NO]** button is effective at all times to stop the laser emission.)
11. Rotate the **[AMS]** knob to display “Iop.Write”.
12. Press the **[YES]** button. When the display becomes Ref=@@.@.@ (@ is an arbitrary number), press the **[YES]** button to display “Measu=@@.@.@” (@ is an arbitrary number).
13. The numbers which can be changed will blink. Input the Iop value noted down at step 9.  
To select the number : Rotate the **[AMS]** knob.  
To select the digit : Press the **[AMS]** knob
14. When the **[YES]** button is pressed, “Complete!” will be displayed momentarily. The value will be recorded in the non-volatile memory and the display will become “Iop Write”.

**Note 1:** After step 4, each time the **[YES]** button is pressed, the display will be switched between “LD 0.7 mW \$  $\square\square$ ”, “LD 6.2 mW \$  $\square\square$ ”, and “LD Wp ホセイ \$  $\square\square$ ”. Nothing needs to be performed here.

## 5-11. TRAVERSE ADJUSTMENT

### Connection :

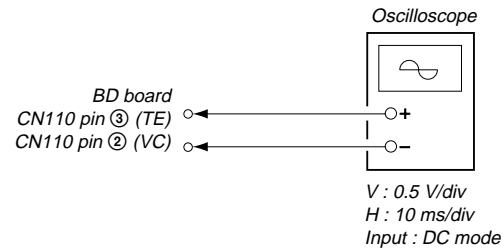

### Adjusting Procedure :

1. Connect an oscilloscope to CN110 pin ③ (TE) and CN110 pin ② (VC) of the BD board.
2. Load a disc (any available on the market). (Refer to Note 1.)
3. Press the **[▶▶]** button and move the optical pick-up outside the pit.
4. Rotate the **[AMS]** knob and display “EF MO ADJUS” (C10).
5. Press the **[YES]** button and display “EFB =  $\square\square$  MO-R”.  
(Laser power READ power/Focus servo ON/tracking servo OFF/spindle (S) servo ON)
6. Rotate the **[AMS]** knob so that the waveform of the oscilloscope becomes the specified value.  
(When the **[AMS]** knob is rotated, the  $\square\square$  of “EFB =  $\square\square$ ” changes and the waveform changes.) In this adjustment, waveform varies at intervals of approx. 2%. Adjust the waveform so that the specified value is satisfied as much as possible.  
(Read power traverse adjustment)

(Traverse Waveform)

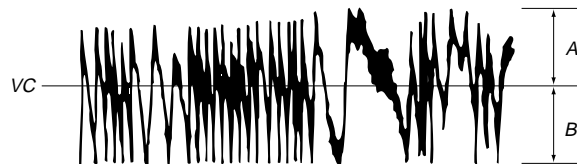

Specification A = B

7. Press the **[YES]** button and save the result of adjustment to the non-volatile memory (“EFB =  $\square\square$  SAV” will be displayed for a moment. Then “EFB =  $\square\square$  MO-W” will be displayed).
8. Rotate the **[AMS]** knob so that the waveform of the oscilloscope becomes the specified value.  
(When the **[AMS]** knob is rotated, the  $\square\square$  of “EFB =  $\square\square$ ” changes and the waveform changes.) In this adjustment, waveform varies at intervals of approx. 2%. Adjust the waveform so that the specified value is satisfied as much as possible.  
(Write power traverse adjustment)

(Traverse Waveform)

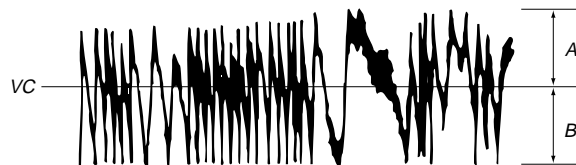

Specification A = B

9. Press the **[YES]** button, and save the adjustment results in the non-volatile memory. (“EFB =  $\square\square$  SAV” will be displayed for a moment.)
10. “EFB =  $\square\square$  MO-P”. will be displayed.  
The optical pick-up moves to the pit area automatically and servo is imposed.



- Rotate the **[AMS]** knob until the waveform of the oscilloscope moves closer to the specified value.  
In this adjustment, waveform varies at intervals of approx. 2%. Adjust the waveform so that the specified value is satisfied as much as possible.

(Traverse Waveform)

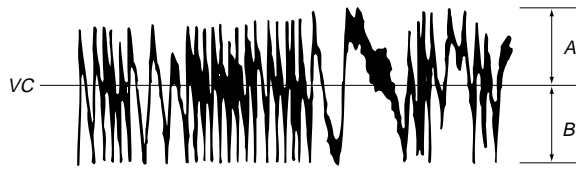

Specification  $A = B$

- Press the **[YES]** button, and save the adjustment results in the non-volatile memory. (“EFB =  $\square\square$  SAV” will be displayed for a moment.)  
Next “EF MO ADJUS” is displayed. The disc stops rotating automatically.
- Press the **[EJECT]** button and remove the disc.
- Load the check disc (MD) TDYS-1.
- Rotate **[AMS]** knob and display “EF CD ADJUS” (C12).
- Press the **[YES]** button and display “EFB =  $\square\square$  CD”. Servo is imposed automatically.
- Rotate the **[AMS]** knob so that the waveform of the oscilloscope moves closer to the specified value.  
In this adjustment, waveform varies at intervals of approx. 2%. Adjust the waveform so that the specified value is satisfied as much as possible.

(Traverse Waveform)

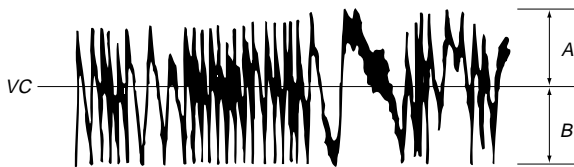

Specification  $A = B$

- Press the **[YES]** button, display “EFB =  $\square\square$  SAV” for a moment and save the adjustment results in the non-volatile memory.  
Next “EF CD ADJUS” will be displayed.
- Press the **[EJECT]** button and remove the check disc (MD) TDYS-1.

**Note 1 :** MO reading data will be erased during if a recorded disc is used in this adjustment.

**Note 2 :** If the traverse waveform is not clear, connect the oscilloscope as shown in the following figure so that it can be seen more clearly.

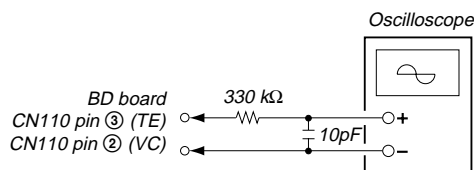

## 5-12. FOCUS BIAS ADJUSTMENT

### Adjusting Procedure :

- Load a test disk (MDW-74/AU-1).
- Rotate the **[AMS]** knob and display “CPLAY MODE” (C29).
- Press the **[YES]** button and display “CPLAY MID”.
- Press the **[MENU/NO]** button when “C =  $\square\square\square$  AD =  $\square\square$ ” is displayed.
- Rotate the **[AMS]** knob and display “FBIAS ADJUST” (C13).
- Press the **[YES]** button and display “ $\square\square\square/\square\square$  a =  $\square\square$ ”.  
The first four digits indicate the C1 error rate, the two digits after [/] indicate ADER, and the 2 digits after [a =] indicate the focus bias value.
- Rotate the **[AMS]** knob in the clockwise direction and find the focus bias value at which the C1 error rate becomes 220 (Refer to Note 2).
- Press the **[YES]** button and display “ $\square\square\square/\square\square$  b =  $\square\square$ ”.
- Rotate the **[AMS]** knob in the counterclockwise direction and find the focus bias value at which the C1 error rate becomes 220.
- Press the **[YES]** button and display “ $\square\square\square/\square\square$  c =  $\square\square$ ”.
- Check that the C1 error rate is below 50 and ADER is 00. Then press the **[YES]** button.
- If the “( )” in “ $\square\square - \square\square - \square\square$  ( )” is above 20, press the **[YES]** button.  
If below 20, press the **[MENU/NO]** button and repeat the adjustment from step 2.
- Press the **[EJECT]** button to remove the test disc.

**Note 1 :** The relation between the C1 error and focus bias is as shown in the following figure. Find points a and b in the following figure using the above adjustment. The focal point position C is automatically calculated from points a and b.

**Note 2 :** As the C1 error rate changes, perform the adjustment using the average value.

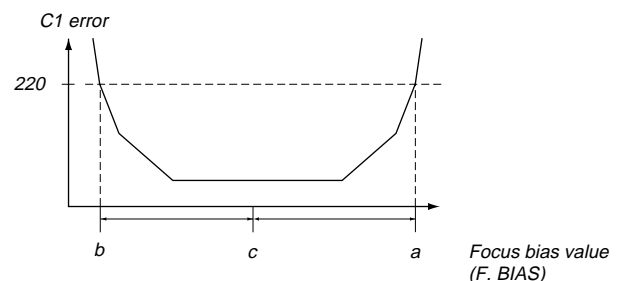

## 5-13. ERROR RATE CHECK

### 5-13-1. CD Error Rate Check

#### Checking Procedure :

1. Load a check disc (MD) TDYS-1.
2. Rotate the [AMS] knob and display "CPLAY MODE" (C29).
3. Press the [YES] button twice and display "CPLAY MID".
4. The display changes to "C = [ ] AD = [ ]".
5. Check that the C1 error rate is below 20.
6. Press the [MENU/NO] button, stop playback, press the [EJECT] button, and remove the test disc.

### 5-13-2. MO Error Rate Check

#### Checking Procedure :

1. Load a test disc (MDW-74/AU-1).
2. Rotate the [AMS] knob and display "CPLAY MODE" (C29).
3. Press the [YES] button and display "CPLAY MID".
4. The display changes to "C1 = [ ] AD = [ ]".
5. If the C1 error rate is below 50, check that ADER is 00.
6. Press the [MENU/NO] button, stop playback, press the [EJECT] button, and remove the test disc.

## 5-14. FOCUS BIAS CHECK

Change the focus bias and check the focus tolerance amount.

#### Checking Procedure :

1. Load a test disc (MDW-74/AU-1).
2. Rotate the [AMS] knob and display "CPLAY MODE" (C29).
3. Press the [YES] button twice and display "CPLAY MID".
4. Press the [MENU/NO] button when "C = [ ] AD = [ ]" is displayed.
5. Rotate the [AMS] knob and display "FBIAS CHECK" (C05).
6. Press the [YES] button and display "[ ]/[ ] c = [ ]".  
The first four digits indicate the C1 error rate, the two digits after [ / ] indicate ADER, and the 2 digits after [ c = ] indicate the focus bias value.  
Check that the C1 error is below 50 and ADER is below 2.
7. Press the [YES] button and display "[ ]/[ ] b = [ ]".  
Check that the C1 error is below 220 and ADER is below 2.
8. Press the [YES] button and display "[ ]/[ ] a = [ ]".  
Check that the C1 error is below 220 and ADER is below 2.
9. Press the [MENU/NO] button, next press the [EJECT] button, and remove the continuously recorded disc.

**Note 1 :** If the C1 error and ADER are above other than the specified value at points a (step 8. in the above) or b (step 7. in the above), the focus bias adjustment may not have been carried out properly. Adjust perform the beginning again.

## 5-15. AUTO GAIN CONTROL OUTPUT LEVEL ADJUSTMENT

Be sure to perform this adjustment when the pickup is replaced. If the adjustment results becomes "Adjust NG!", the pickup may be faulty or the servo system circuits may be abnormal.

### 5-15-1. CD Auto Gain Control Output Level Adjustment

#### Adjusting Procedure :

1. Insert the check disc (MD) TDYS-1.
2. Rotate the [AMS] knob to display "AG Set (CD)" (C26).
3. When the [YES] button is pressed, the adjustment will be performed automatically.  
"Complete!!" will then be displayed momentarily when the value is recorded in the non-volatile memory, after which the display changes to "AG Set (CD)".
4. Press the [EJECT] button to remove the disc.

### 5-15-2. MO Auto Gain Control Output Level Adjustment

#### Adjusting Procedure :

1. Insert the reference disc (MDW-74/AU-1) for recording.
2. Rotate the [AMS] knob to display "AG Set (MO)" (C25).
3. When the [YES] button is pressed, the adjustment will be performed automatically.  
"Complete!!" will then be displayed momentarily when the value is recorded in the non-volatile memory, after which the display changes to "AG Set (MO)".
4. Press the [EJECT] button to remove the disc.

## 5-15. ADJUSTING POINTS AND CONNECTING POINTS

### [BD BOARD] (SIDE A)

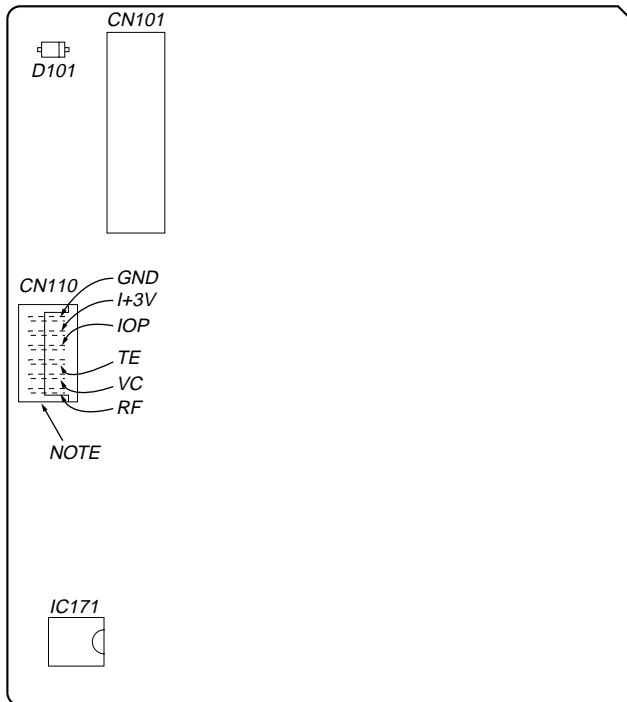

### [BD BOARD] (SIDE B)

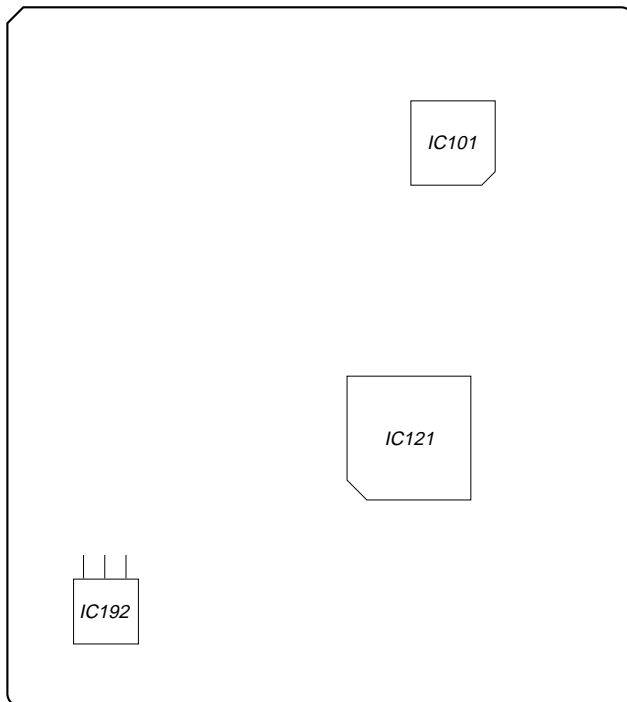

**NOTE:** It is useful to use the jig. for checking the waveform. (Refer to Servicing Note on page 6.)

# SECTION 6 DIAGRAMS

## 6-1. CIRCUIT BOARDS LOCATION

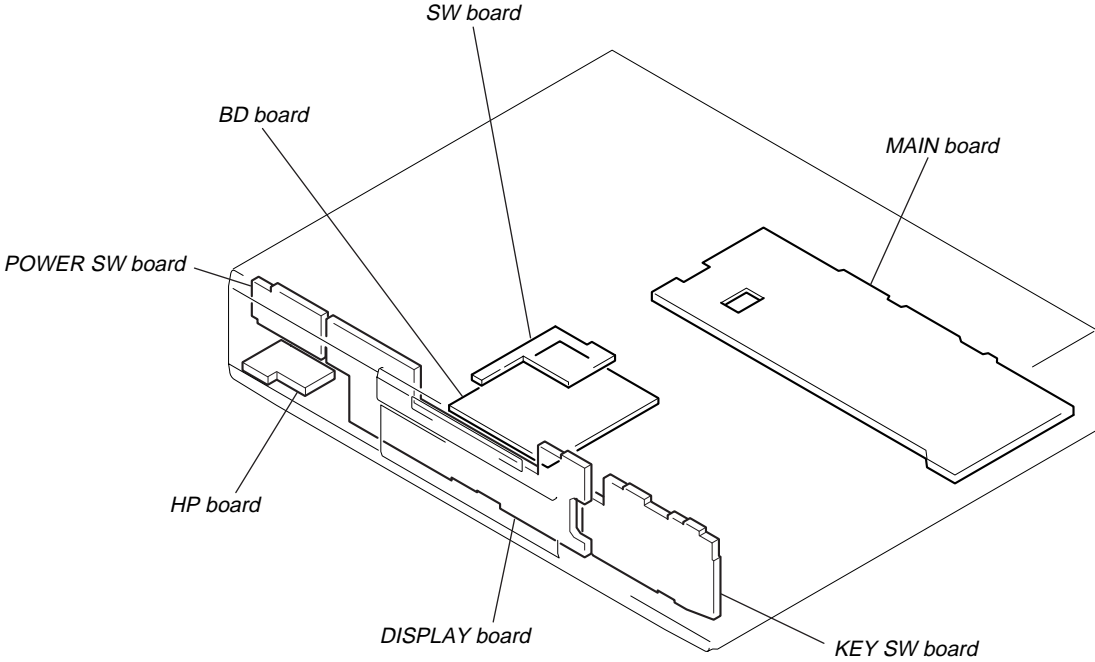

6-2. BLOCK DIAGRAMS  
- BD SECTION -

- Signal path
- ▬ : PB
- ▬ : REC
- ▬ : PB (Digital out)
- ▬ : REC (Digital in)

DIGITAL SERVO SIGNAL PROCESSOR, DIGITAL SIGNAL PROCESSOR  
EFM/ACIRC ENCODER/DECODER, SHOCK-PROOF MEMORY CONTROLLER,  
ATRAC ENCODER/DECODER  
IC121

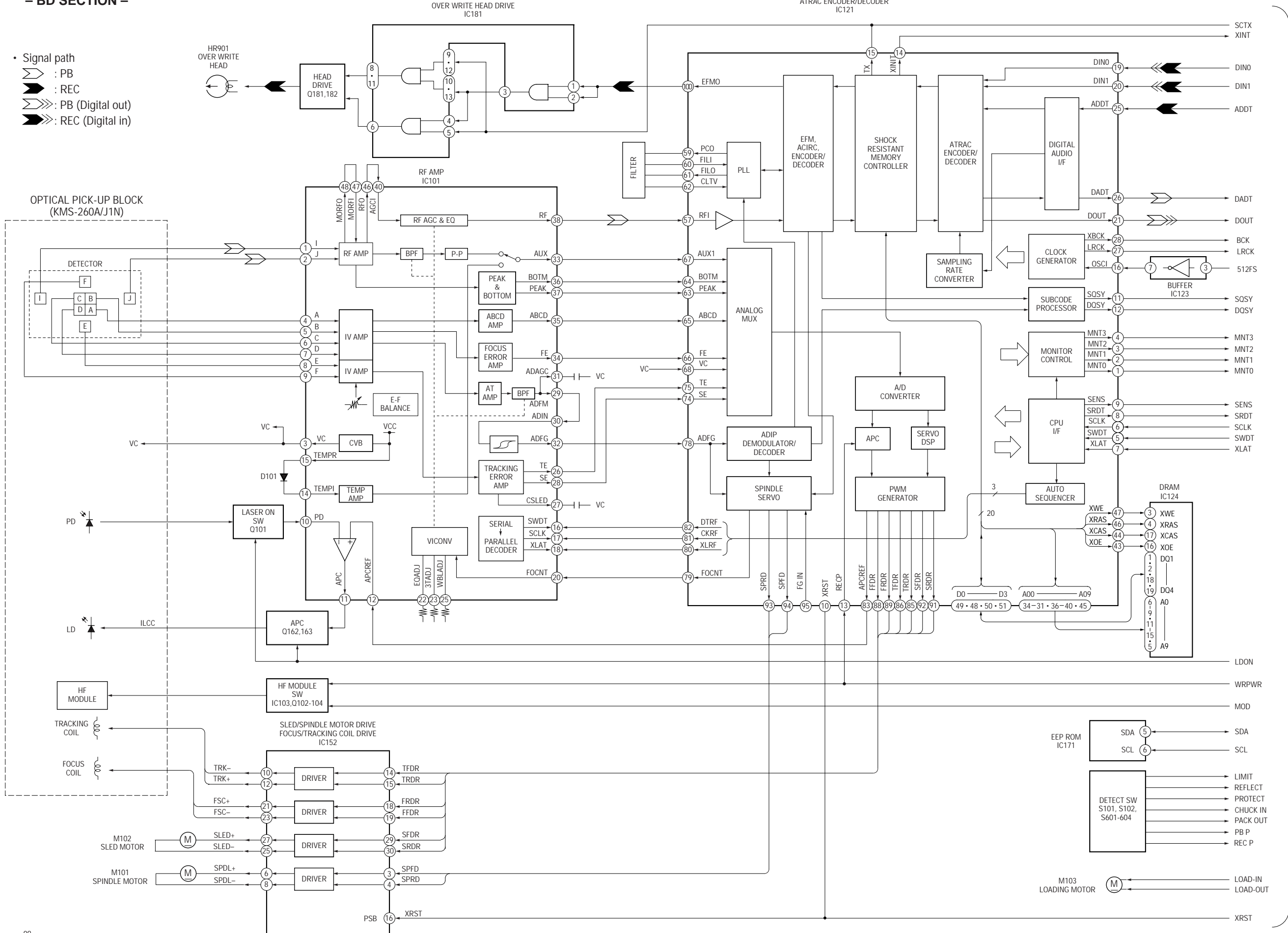

- MAIN SECTION -

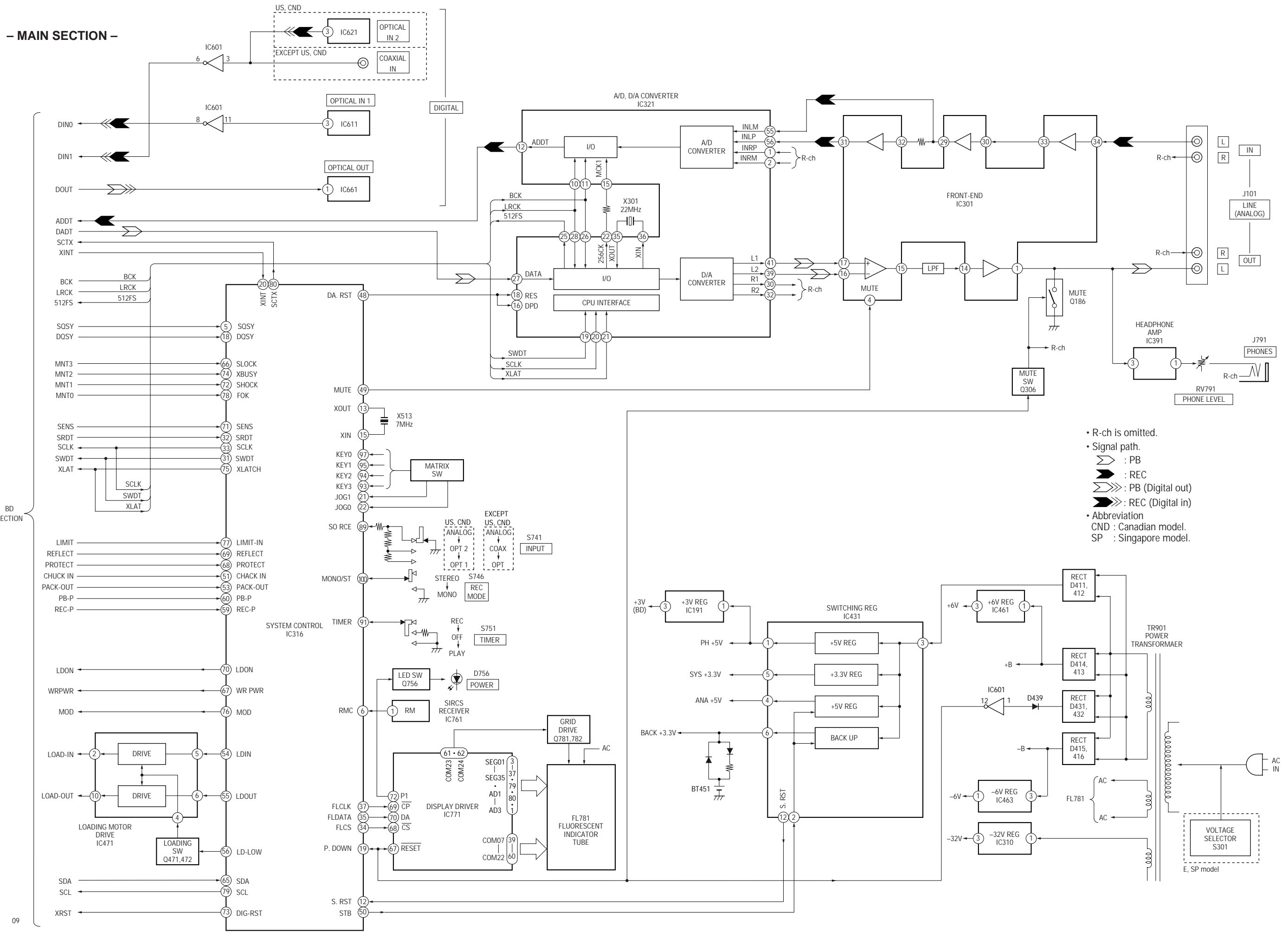

**THIS NOTE IS COMMON FOR PRINTED WIRING BOARDS AND SCHEMATIC DIAGRAMS.**  
**(In addition to this, the necessary note is printed in each block.)**

**For schematic diagrams.**

**Note:**











- All capacitors are in  $\mu\text{F}$  unless otherwise noted. pF:  $\mu\mu\text{F}$   
50 WV or less are not indicated except for electrolytics and tantalums.
- All resistors are in  $\Omega$  and  $1/4\text{ W}$  or less unless otherwise specified.
- $\triangle$  : internal component.
-  : panel designation.

**Note:**

The components identified by mark  $\triangle$  or dotted line with mark  $\triangle$  are critical for safety.  
 Replace only with part number specified.





**Note:**

Les composants identifiés par une marque  $\triangle$  sont critiques pour la sécurité.  
 Ne les remplacer que par une pièce portant le numéro spécifié.

-  : B+ Line.
-  : B- Line.
-  : adjustment for repair.
- Voltages and waveforms are dc with respect to ground in playback mode.  
no mark : STOP  
(  ) : Play the test disc (TDYS-1)  
<  > : REC  
\*  : can not be measured.
- Voltages are taken with a VOM (Input impedance 10 M $\Omega$ ).  
Voltage variations may be noted due to normal production tolerances.
- Waveforms are taken with a oscilloscope.  
Voltage variations may be noted due to normal production tolerances.
- Circled numbers refer to waveforms.
- Signal path.  
 : PB  
 : REC  
 : PB (Digital out)  
 : PB (Digital in)
- Abbreviation  
CND : Canadian model.  
SP : Singapore model.

**For printed wiring boards.**

**Note:**

-  : parts extracted from the component side.
-  : parts extracted from the conductor side.
-  : parts mounted on the conductor side.
-  : Through hole.
-  : Pattern from the side which enables seeing.  
(The other layers' patterns are not indicated.)

**Caution:**

Pattern face side: Parts on the pattern face side seen from the (Side B) pattern face are indicated.  
 Parts face side: Parts on the parts face side seen from the (Side A) parts face are indicated.



WAVEFORMS

• BD BOARD (1/2)

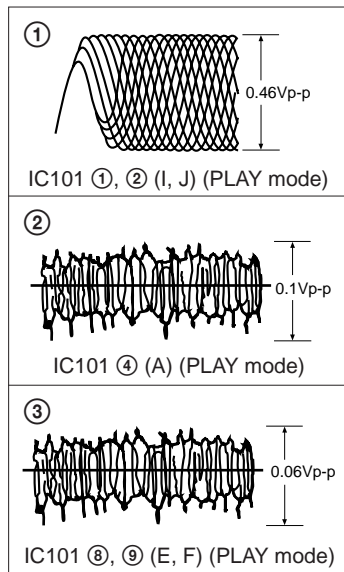

• BD BOARD (2/2)

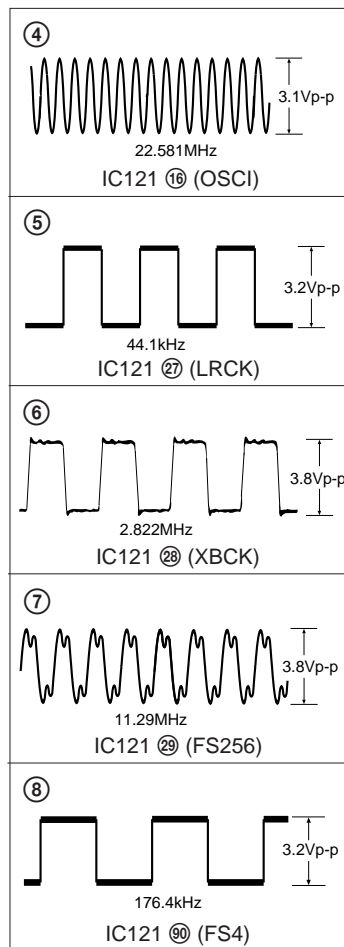

• MAIN BOARD

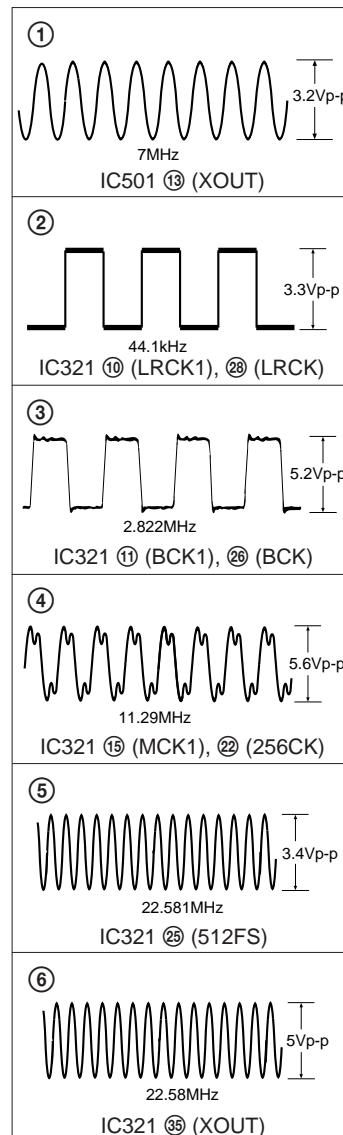

• DISPLAY BOARD



6-3. PRINTED WIRING BOARD — BD SECTION —

• See page 44 for Circuit Boards Location.

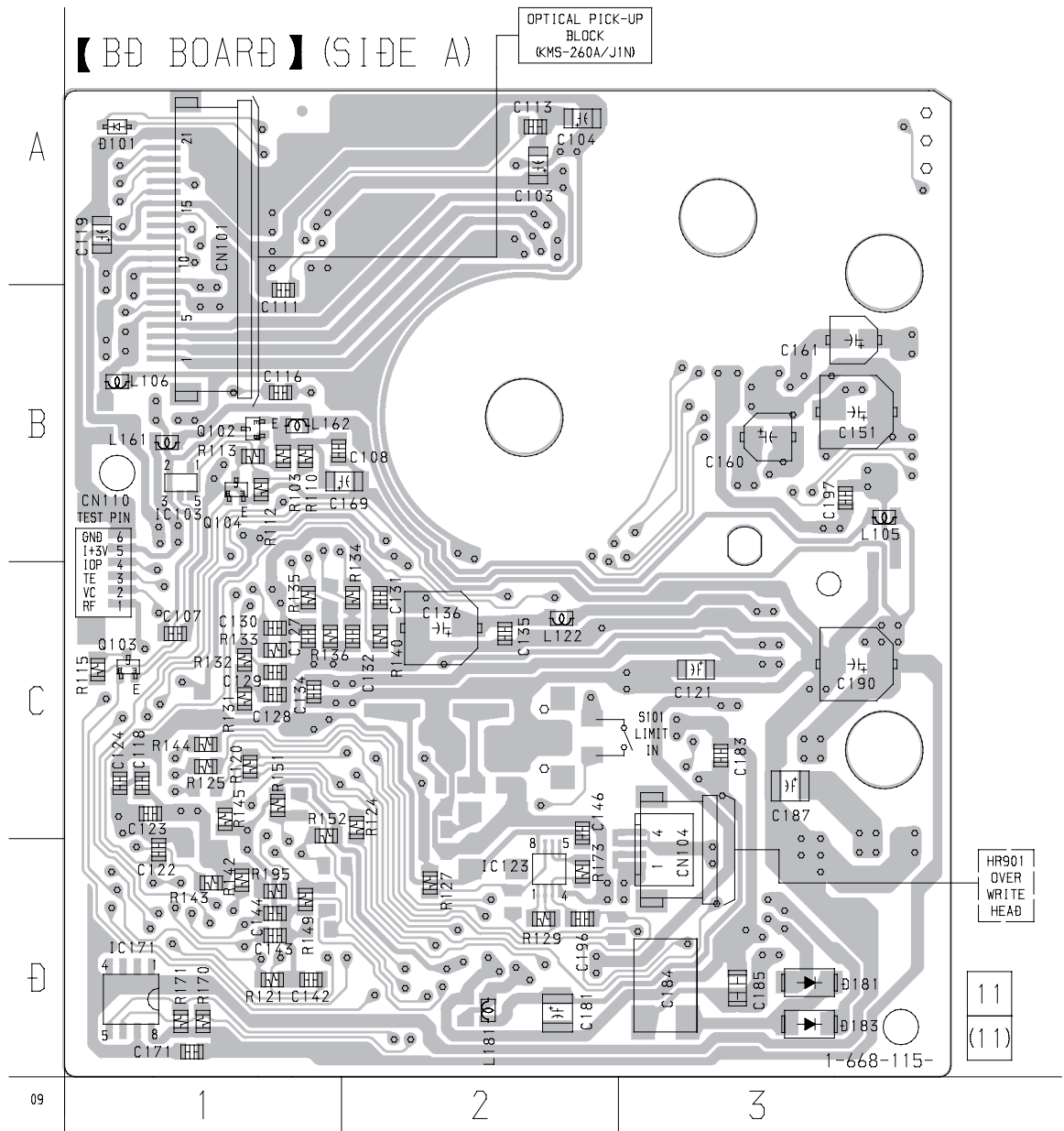

BD BOARD (SIDE A)

• Semiconductor Location

Ref. No.	Location
D101	A-1
D181	D-3
D183	D-3
IC103	B-1
IC171	D-1
Q102	B-1
Q103	B-1
Q104	B-1

• Indication of transistor

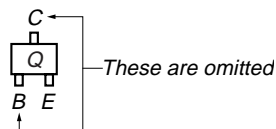

# 【 BD BOARD 】 (SIDE B)

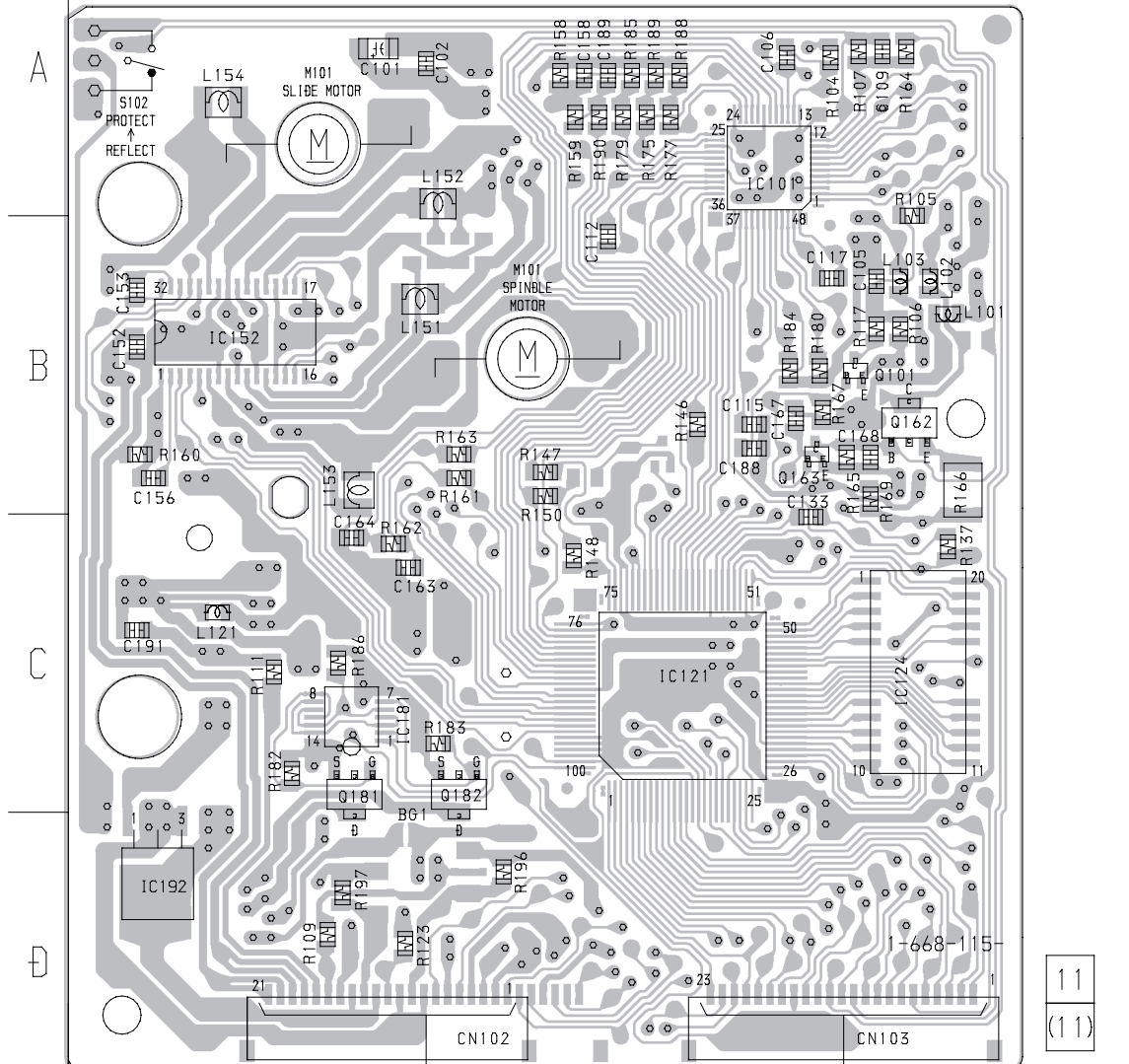

(Page 62) A

(Page 62) B

## BD BOARD (SIDE B)

### • Semiconductor Location

Ref. No.	Location
IC101	A-3
IC121	C-3
IC123	D-2
IC124	C-3
IC152	B-1
IC181	C-1
IC192	D-1
Q101	B-3
Q162	B-3
Q163	B-3
Q181	C-1
Q182	C-2

6-4. SCHEMATIC DIAGRAM – BD SECTION – (1/2)

- See page 50 for Waveforms.
- See page 68 for IC Block Diagrams.
- See page 72 for IC Pin Functions.

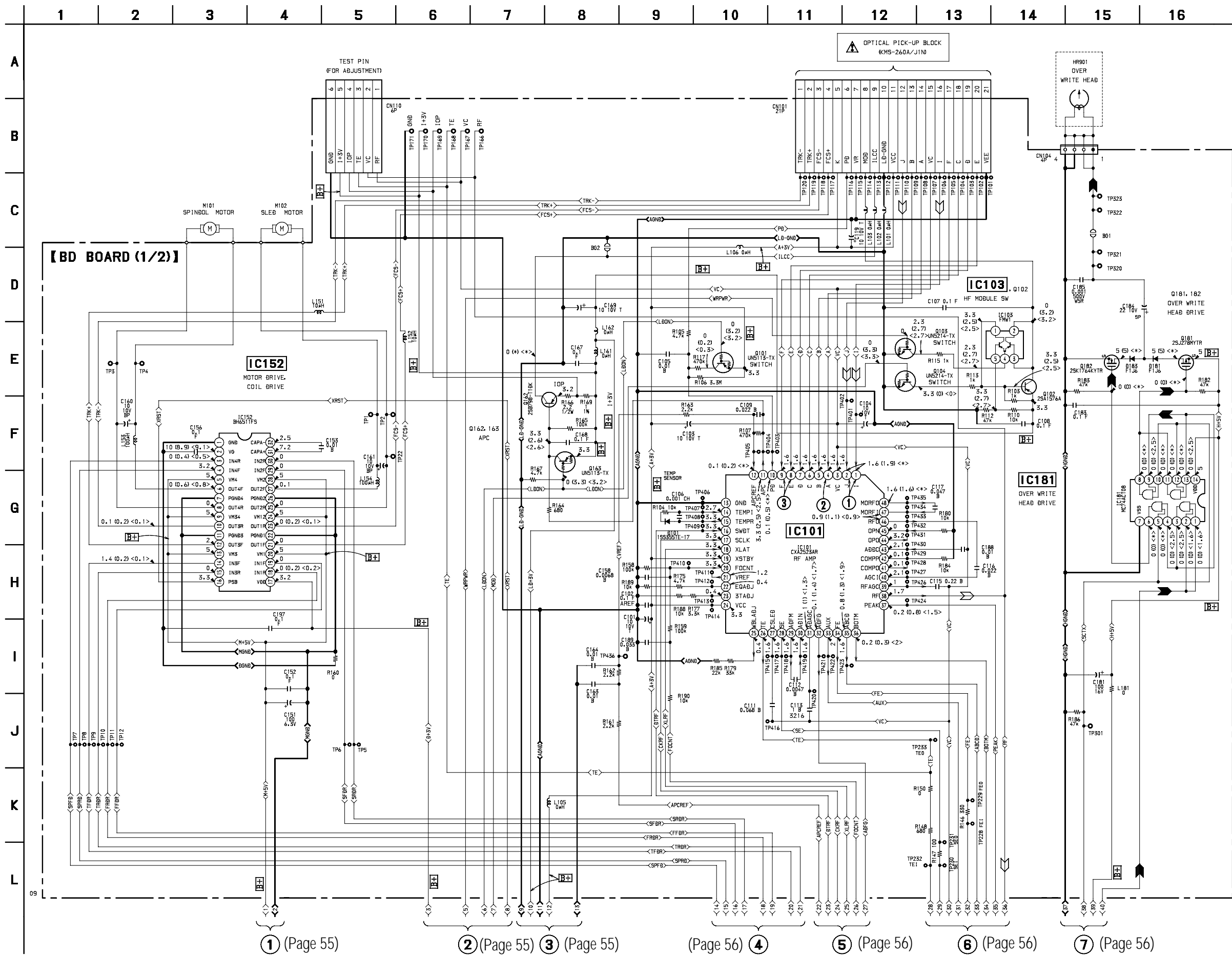

① (Page 55)                      ② (Page 55)   ③ (Page 55)                      (Page 56)   ④                      ⑤ (Page 56)                      ⑥ (Page 56)                      ⑦ (Page 56)



6-5. SCHEMATIC DIAGRAM – MAIN SECTION – (1/2)

- See page 50 for Waveforms.
- See page 61 Printed Wiring Board.
- See page 70 for IC Block Diagrams.
- See page 76 for IC Pin Functions.

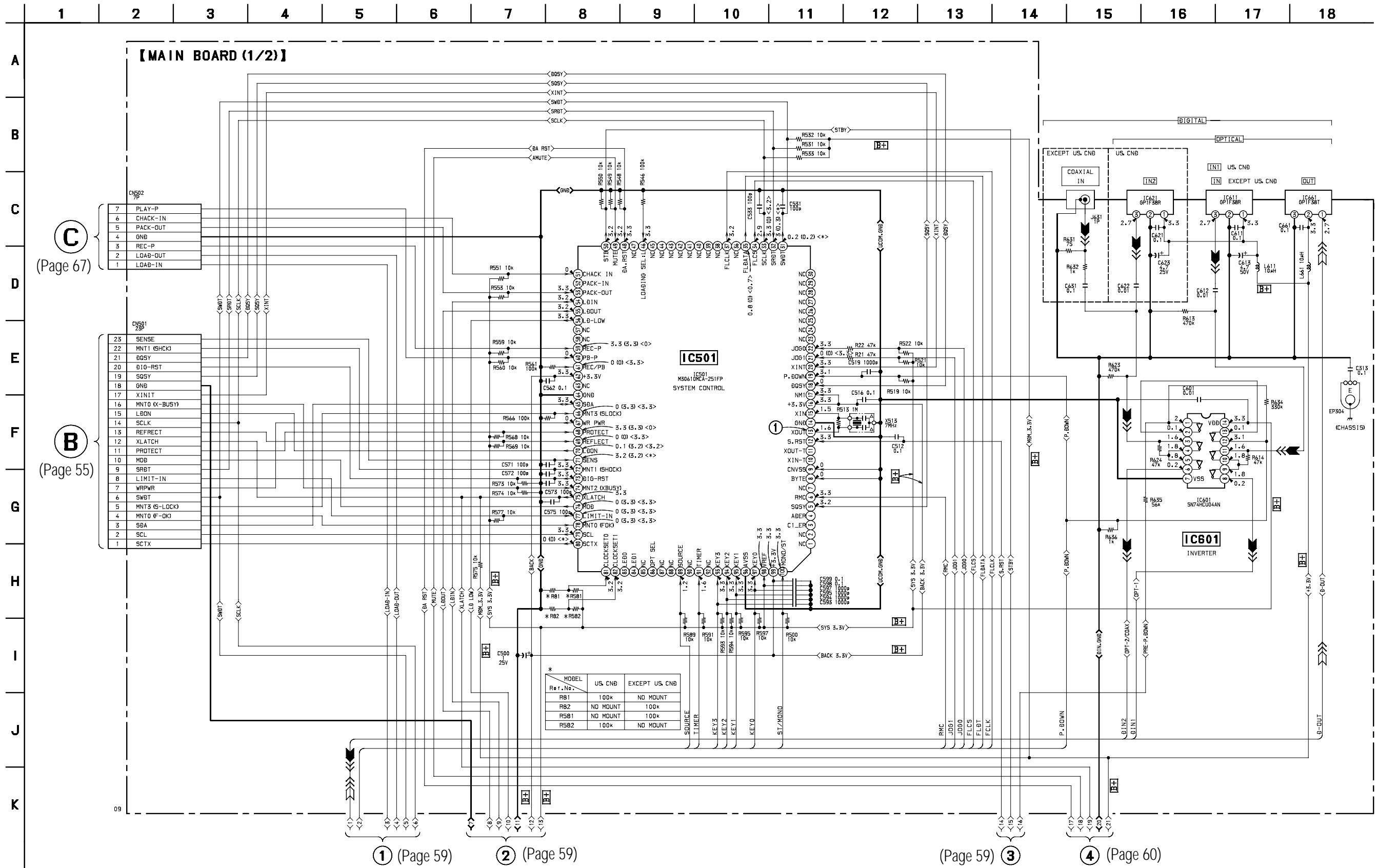



SCHEMATIC DIAGRAM – MAIN SECTION – (2/2)

• See page 50 for Waveforms.  
• See page 70 for IC Block Diagrams.

• See page 76 for IC Pin Functions.

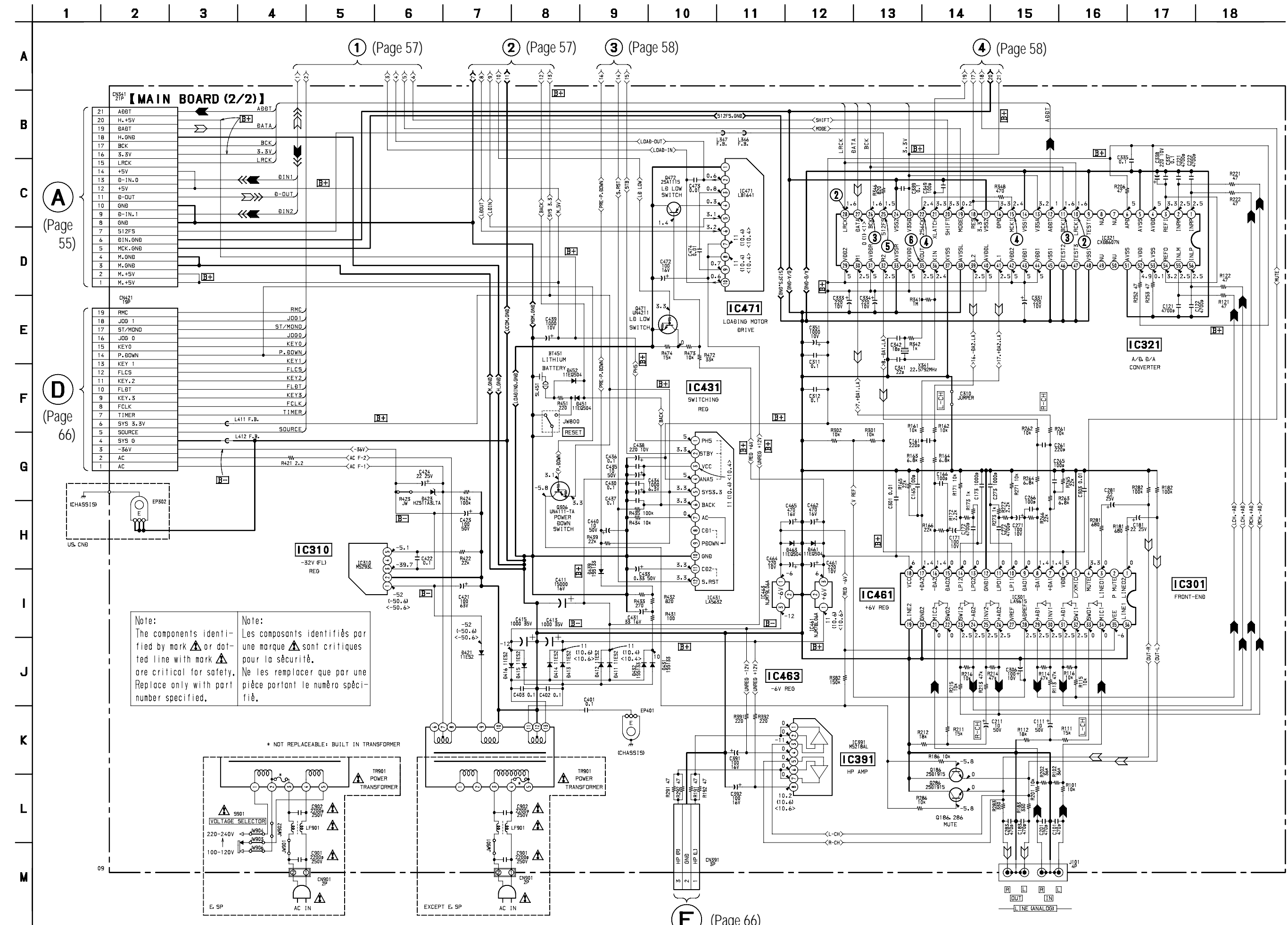

(Page 55)

(Page 66)

(Page 66)



6-6. PRINTED WIRING BOARD – MAIN SECTION –  
 • See page 44 for Circuit Boards Location.

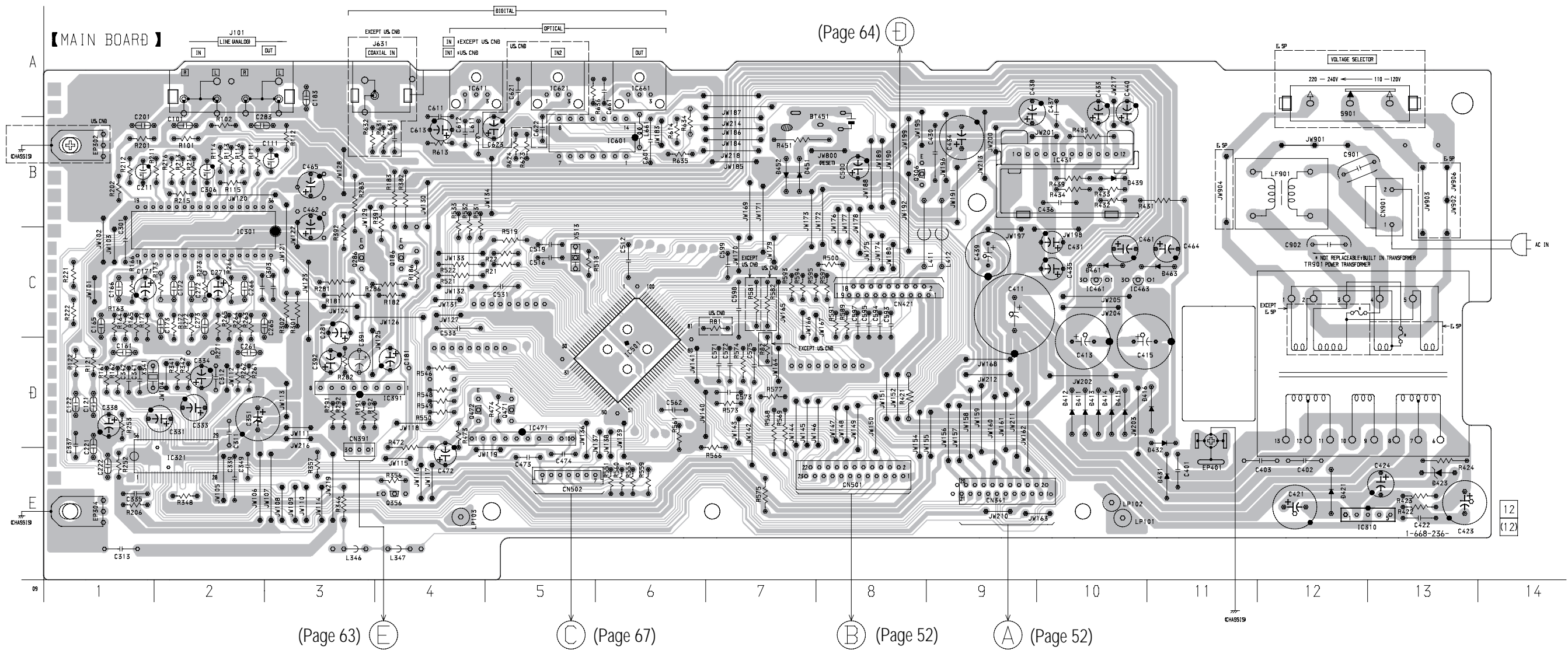

• Semiconductor Location

Ref. No.	Location	Ref. No.	Location
D411	D-10	IC321	E-2
D412	D-10	IC391	D-4
D413	D-10	IC461	C-10
D414	D-10	IC463	C-10
D415	D-10	IC471	D-5
D416	D-11	IC501	D-6
D421	E-12	IC601	B-6
D423	E-13	IC611	A-4
D431	E-11	IC621	A-5
D432	D-11	IC661	A-6
D439	B-10		
D451	B-7	Q186	C-4
D452	B-7	Q286	C-3
D461	C-10	Q306	B-8
D463	C-11	Q356	E-4
		Q471	D-5
IC301	C-2	Q472	D-4
IC310	E-13		

• Indication of transistor

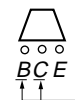

These are omitted

6-7. PRINTED WIRING BOARD – PANEL SECTION –  
 • See page 44 for Circuit Boards Location.

【 DISPLAY BOARD 】

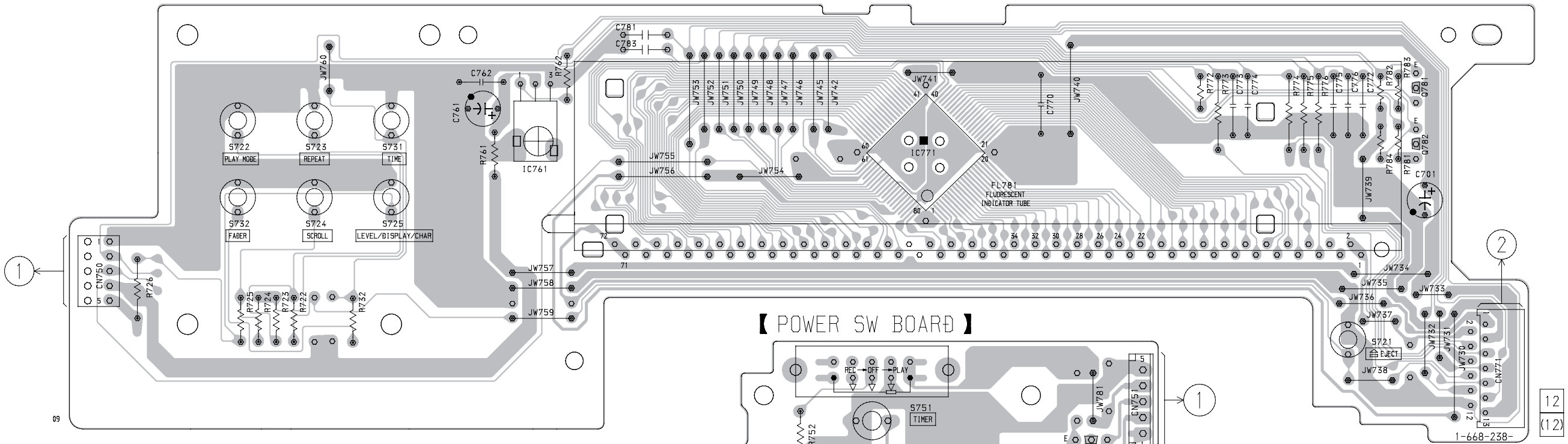

【 POWER SW BOARD 】

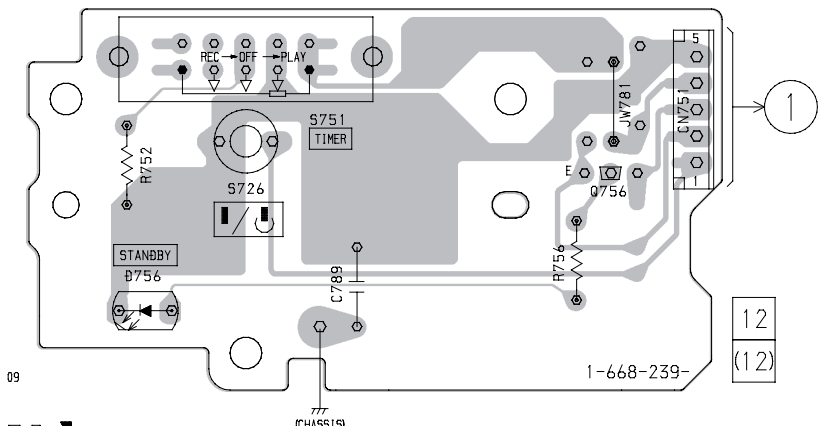

【 HP BOARD 】

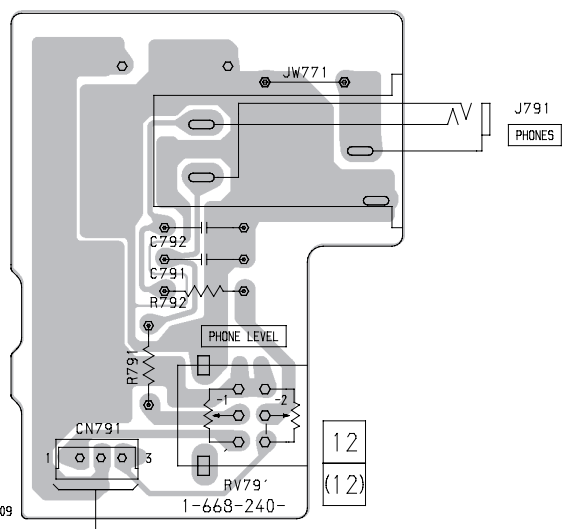

【 KEY SW BOARD 】

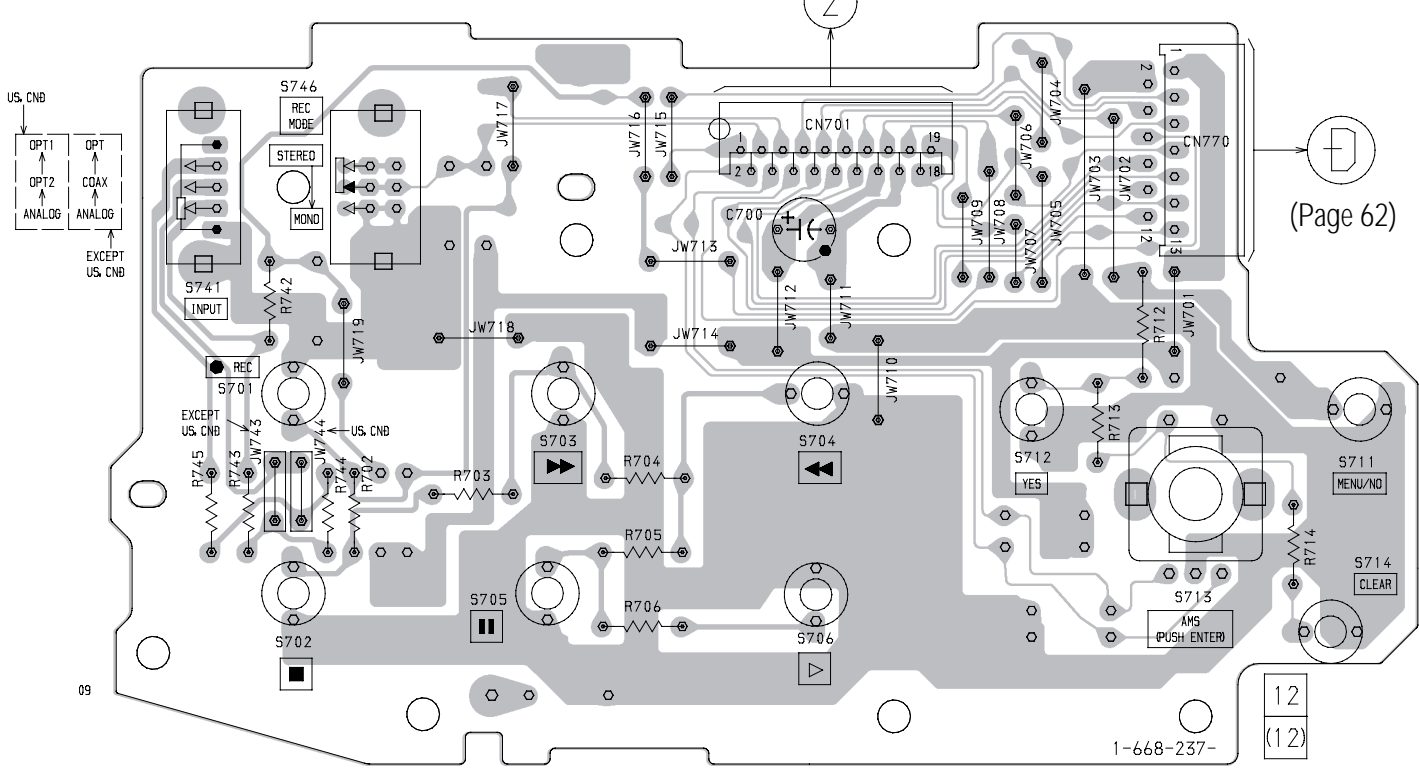

• Indication of transistor  
  
 These are omitted

6-8. SCHEMATIC DIAGRAM – PANEL SECTION –

- See page 50 for Waveforms.
- See page 78 for IC Pin Functions.

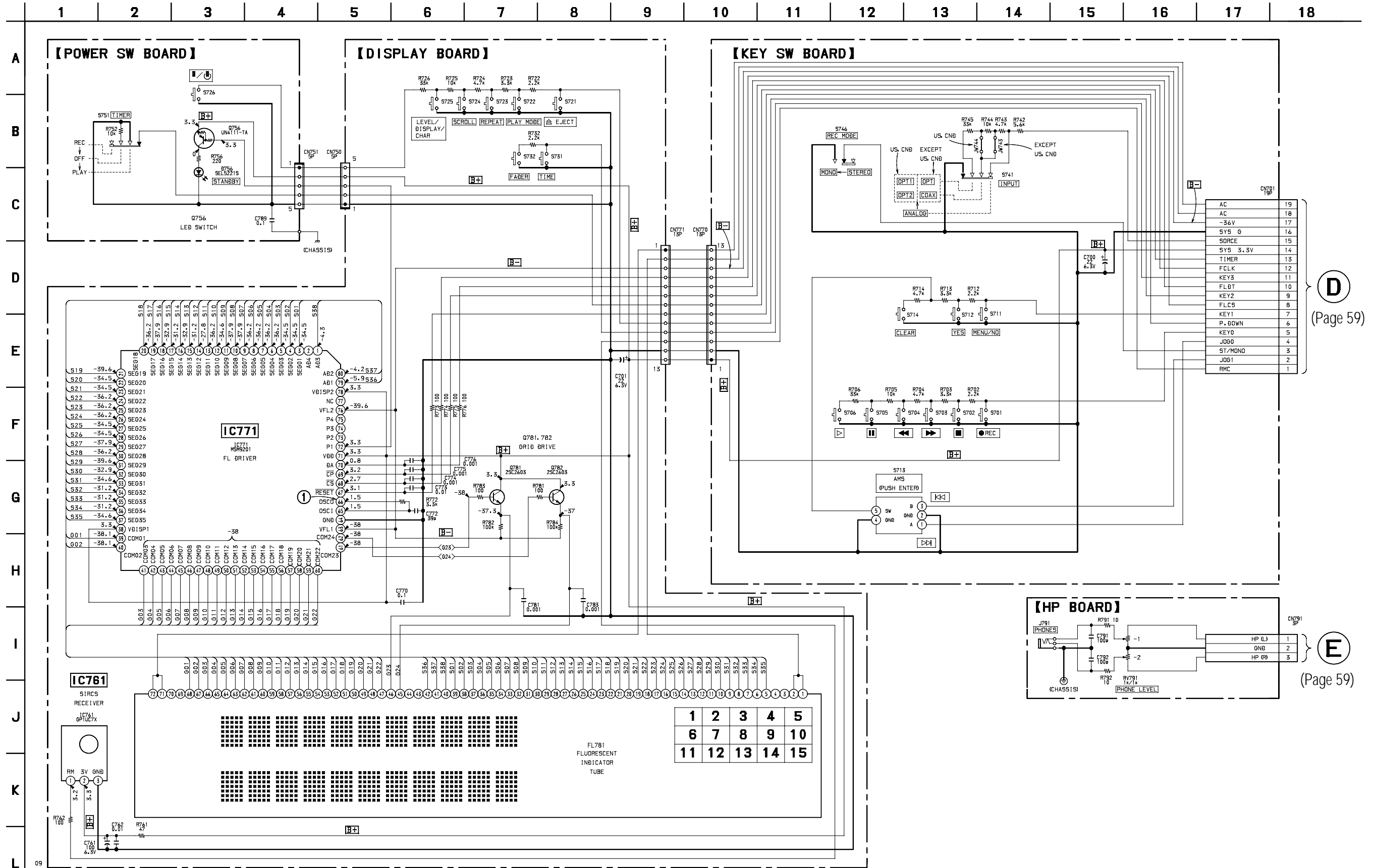

(Page 59)

(Page 59)

6-9. SCHEMATIC DIAGRAM – BD SWITCH SECTION –

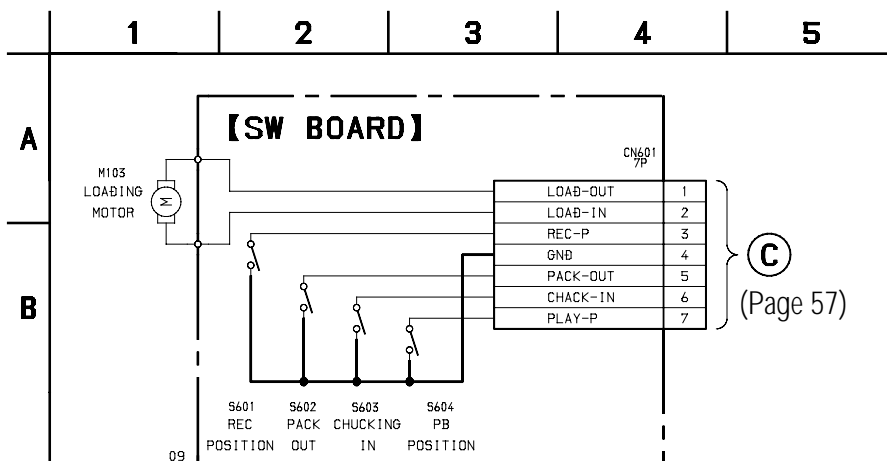

6-10. PRINTED WIRING BOARD – BD SWITCH SECTION –

• See page 44 for Circuit Boards Location.

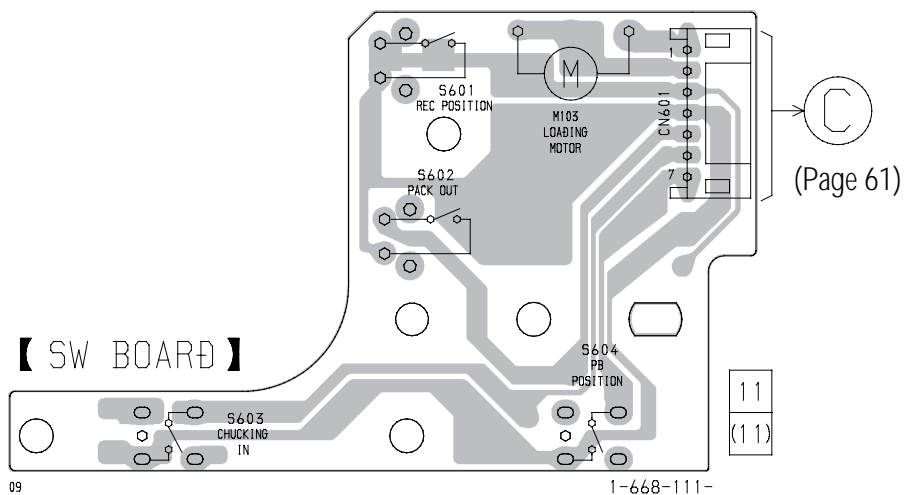

# 6-11. IC BLOCK DIAGRAMS

• BD section

## IC101 CXA2523AR

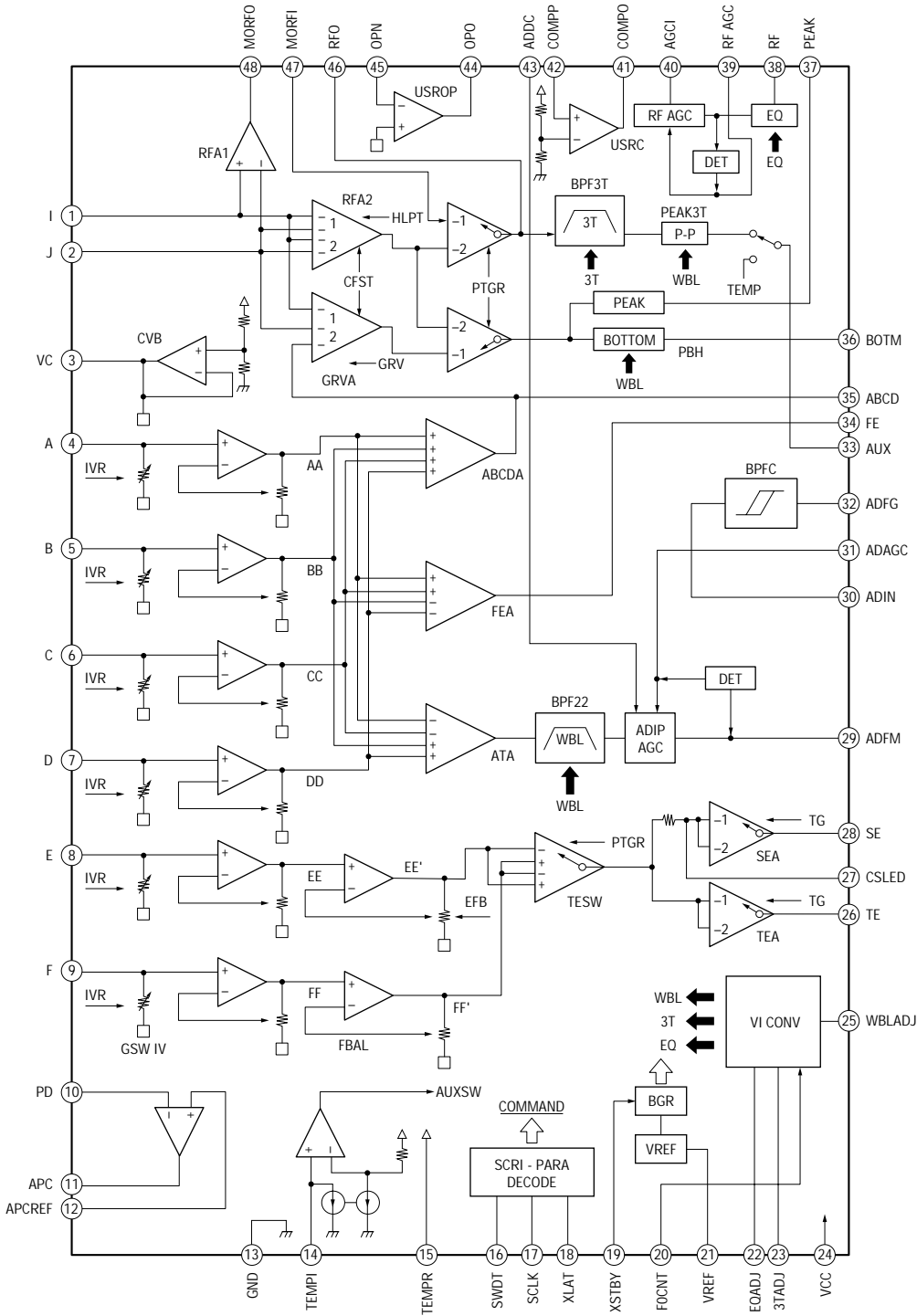

### IC121 CXD2654R

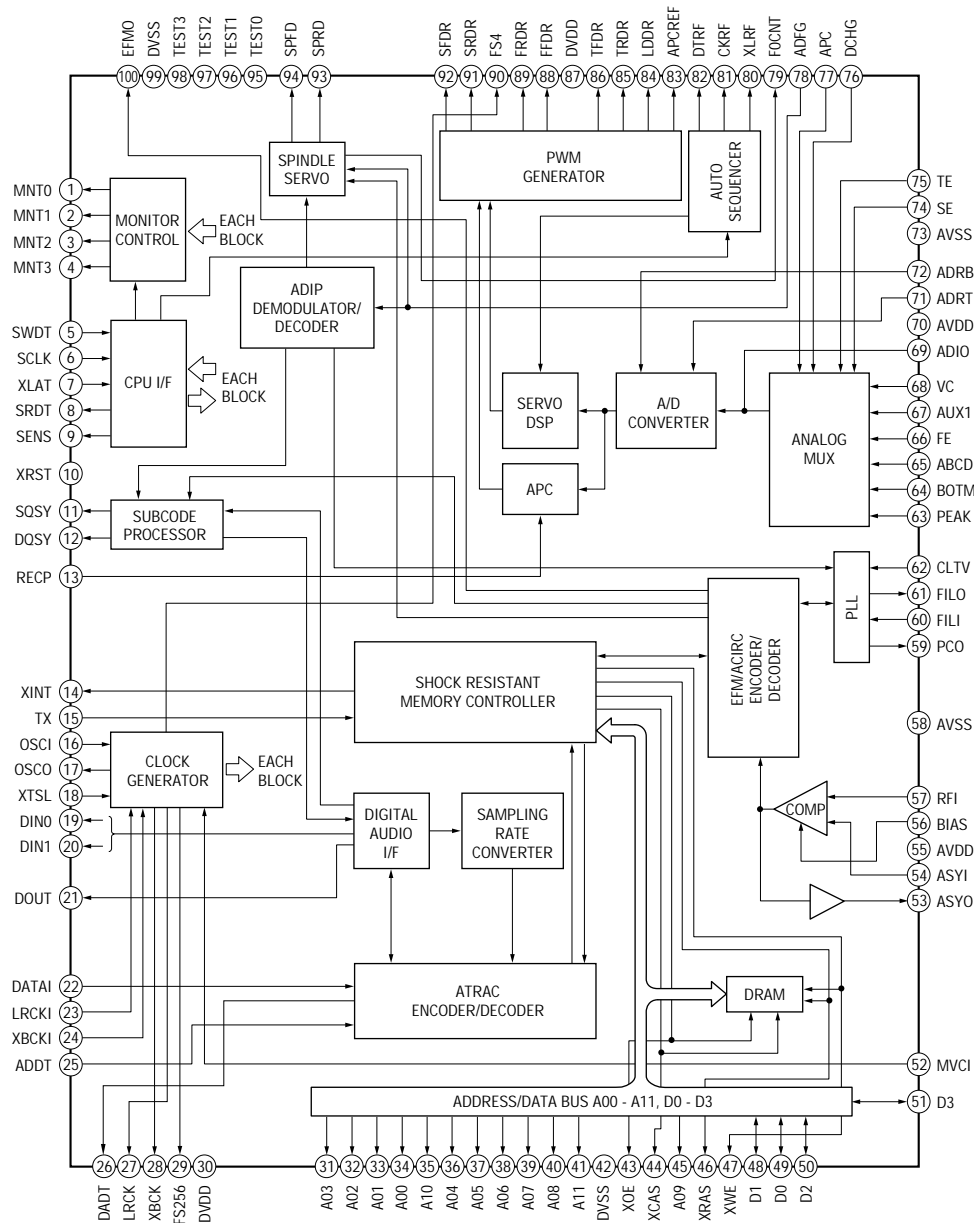

### IC152 BH6511FS

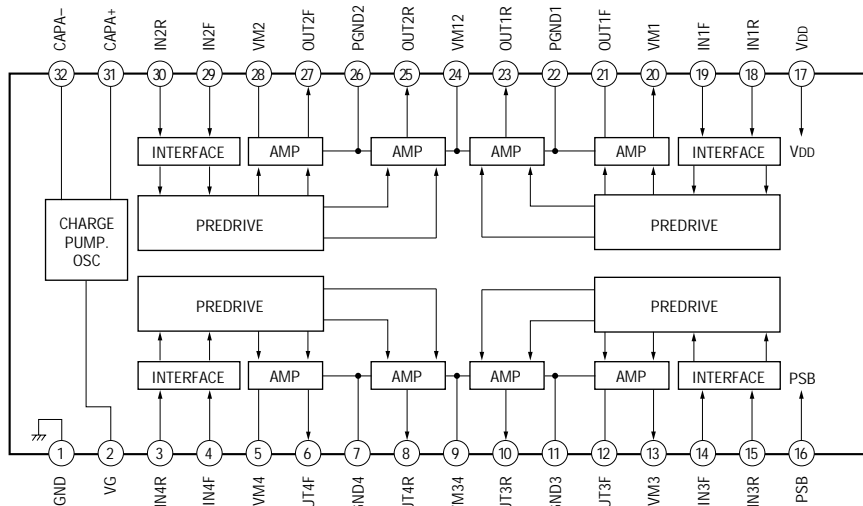



• MAIN section

IC310 M5293L

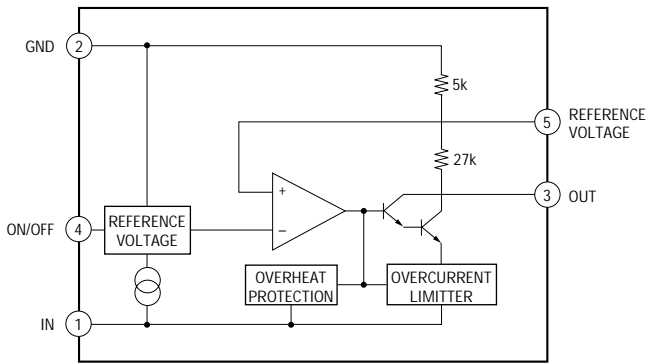

IC321 CXD8607N

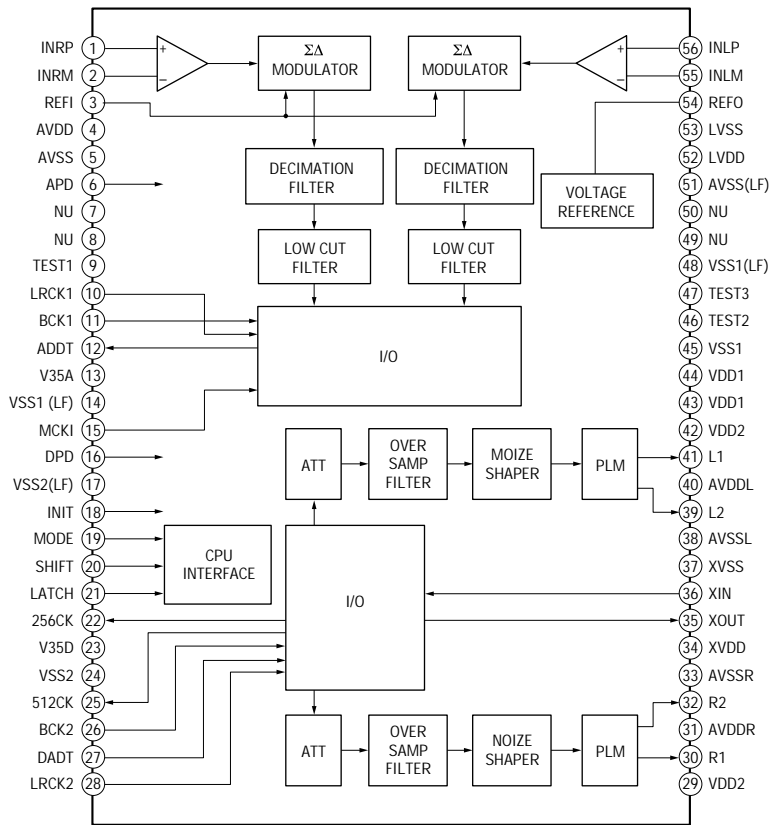

IC391 M5218AL

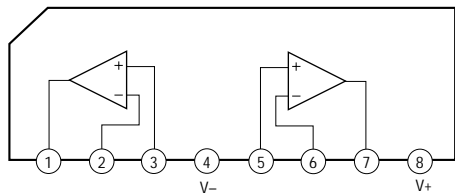



**IC431 LA5632**

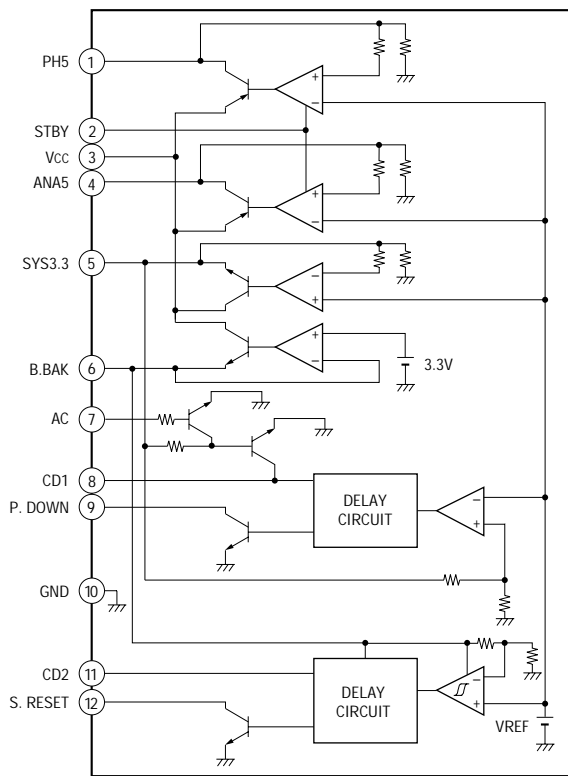

**IC471 LB1641**

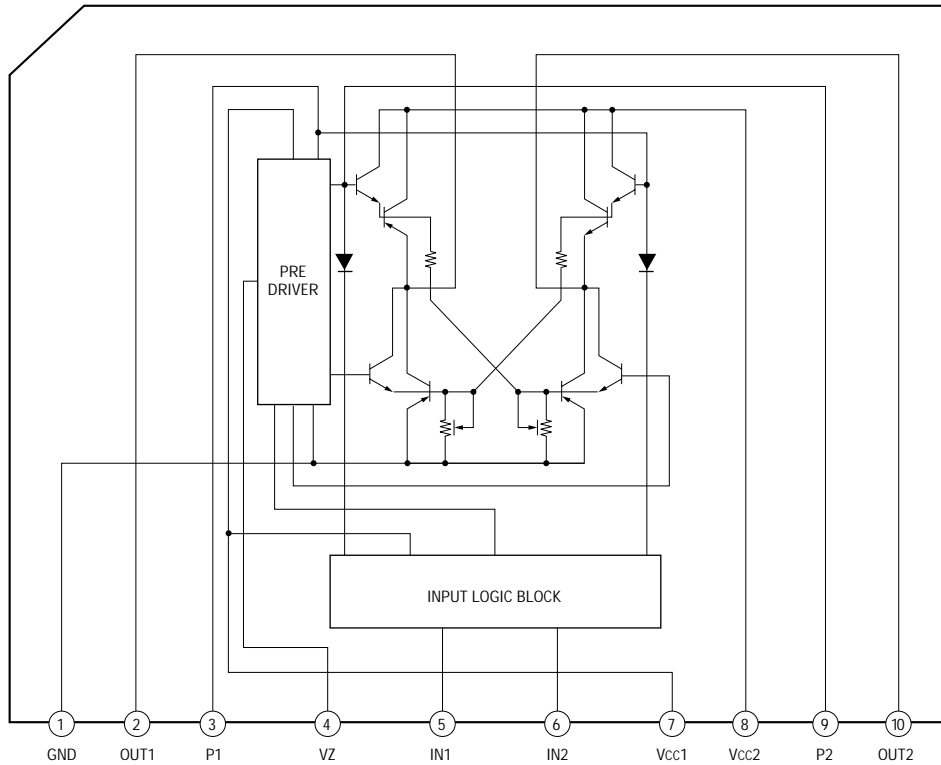

## 6-12. IC PIN FUNCTIONS

### • IC101 RF Amplifier (CXA2523R)

Pin No.	Pin Name	I/O	Function
1	I	I	I-V converted RF signal I input
2	J	I	I-V converted RF signal J input
3	VC	O	Middle point voltage (+1.5V) generation output
4 to 9	A to F	I	Signal input from the optical pick-up detector
10	PD	I	Light amount monitor input
11	APC	O	Laser APC output
12	APCREF	I	Reference voltage input for setting laser power
13	GND	—	Ground
14	TEMPI	I	Temperature sensor connection
15	TEMPR	O	Reference voltage output for the temperature sensor
16	SWDT	I	Serial data input from the CXD2650R or CXD2652AR
17	SCLK	I	Serial clock input from the CXD2650R or CXD2652AR
18	XLAT	I	Latch signal input from the CXD2650R or CXD2652AR “L”: Latch
19	XSTBY	I	Stand by signal input “L”: Stand by
20	F0CNT	I	Center frequency control voltage input of BPF22, BPF3T, EQ from the CXD2650R or CXD2652AR
21	VREF	O	Reference voltage output (Not used)
22	EQADJ	I/O	Center frequency setting pin for the internal circuit EQ
23	3TADJ	I/O	Center frequency setting pin for the internal circuit BPF3T
24	Vcc	—	+3V power supply
25	WBLADJ	I/O	Center frequency setting pin for the internal circuit BPF22
26	TE	O	Tracking error signal output to the CXD2650R or CXD2652AR
27	CSLED	—	External capacitor connection pin for the sled error signal LPF
28	SE	O	Sled error signal output to the CXD2650R or CXD2652AR
29	ADFM	O	FM signal output of ADIP
30	ADIN	I	ADIP signal comparator input ADFM is connected with AC coupling
31	ADAGC	—	External capacitor connection pin for AGC of ADIP
32	ADFG	O	ADIP duplex signal output to the CXD2650R or CXD2652AR
33	AUX	O	I3 signal/temperature signal output to the CXD2650R or CXD2652AR (Switching with a serial command)
34	FE	O	Focus error signal output to the CXD2650R or CXD2652AR
35	ABCD	O	Light amount signal output to the CXD2650R or CXD2652AR
36	BOTM	O	RF/ABCD bottom hold signal output to the CXD2650R or CXD2652AR
37	PEAK	O	RF/ABCD peak hold signal output to the CXD2650R or CXD2652AR
38	RF	O	RF equalizer output to the CXD2650R or CXD2652AR
39	RFAGC	—	External capacitor connection pin for the RF AGC circuit
40	AGCI	I	Input to the RF AGC circuit The RF amplifier output is input with AC coupling
41	COMPO	O	User comparator output (Not used)
42	COMPP	I	User comparator input (Fixed at “L”)
43	ADDC	I/O	External capacitor pin for cutting the low band of the ADIP amplifier
44	OPO	O	User operation amplifier output (Not used)
45	OPN	I	User operation amplifier inversion input (Fixed at “L”)
46	RFO	O	RF amplifier output
47	MORFI	I	Groove RF signal is input with AC coupling
48	MORFO	O	Groove RF signal output

#### • Abbreviation

APC: Auto Power Control

AGC: Auto Gain Control

• IC121 Digital Signal Processor, Digital Servo Signal Processor, EFM/ACIRC Encoder/Decoder, Shock-proof Memory Controller, ATRAC Encoder/Decoder, 2M Bit DRAM (CXD2654R)

Pin No.	Pin Name	I/O	Function
1	MNT0 (FOK)	O	FOK signal output to the system control (monitor output) “H” is output when focus is on
2	MNT1 (SHCK)	O	Track jump detection signal output to the system control (monitor output)
3	MNT2 (XBUSY)	O	Monitor 2 output to the system control (monitor output)
4	MNT3 (SLOC)	O	Monitor 3 output to the system control (monitor output)
5	SWDT	I	Writing data signal input from the system control
6	SCLK	I (S)	Serial clock signal input from the system control
7	XLAT	I (S)	Serial latch signal input from the system control
8	SRDT	O (3)	Reading data signal output to the system control
9	SENS	O (3)	Internal status (SENSE) output to the system control
10	XRST	I (S)	Reset signal input from the system control “L”: Reset
11	SQSY	O	Subcode Q sync (SCOR) output to the system control “L” is output every 13.3 msec. Almost all, “H” is output
12	DQSY	O	Digital In U-bit CD format or MD format subcode Q sync (SCOR) output to the system control
13	RECP	I	Laser power switching input from the system control “H”: Recording, “L”: Playback
14	XINT	O	Interrupt status output to the system control
15	TX	I	Recording data output enable input from the system control
16	OSCI	I	System clock input (512Fs=22.5792 MHz)
17	OSCO	O	System clock output (512Fs=22.5792 MHz) (Not used)
18	XTSL	I	System clock frequency setting “L”: 45.1584 MHz, “H”: 22.5792 MHz (Fixed at “H”)
19	DIN0	I	Digital audio input (Optical input)
20	DIN1	I	Digital audio input (Optical input)
21	DOUT	O	Digital audio output (Optical output)
22	DADTI	I	Serial data input
23	LRCKI	I	LR clock input “H”: Lch, “L”: R ch
24	XBCKI	I	Serial data clock input
25	ADDT	I	Data input from the A/D converter
26	DADT	O	Data output to the D/A converter
27	LRCK	O	LR clock output for the A/D and D/A converter (44.1 kHz)
28	XBCK	O	Bit clock output to the A/D and D/A converter (2.8224 MHz)
29	FS256	O	11.2896 MHz clock output (Not used)
30	DVDD	—	+3V power supply (Digital)
31 to 34	A03 to A00	O	DRAM address output
35	A10	O	DRAM address output (Not used)
36 to 40	A04 to A08	O	DRAM address output
41	A11	O	DRAM address output (Not used)
42	DVSS	—	Ground (Digital)
43	XOE	O	Output enable output for DRAM
44	XCAS	O	CAS signal output for DRAM
45	A09	O	Address output for DRAM
46	XRAS	O	RAS signal output for DRAM
47	XWE	O	Write enable signal output for DRAM (Used : CXD2652AR, Not used : CXD2650R)

\* I (S) stands for Schmidt input, I (A) for analog input, O (3) for 3-state output, and O (A) for analog output in the column I/O

Pin No.	Pin Name	I/O	Function
48	D1	I/O	Data input/output for DRAM
49	D0	I/O	
50, 51	D2, D3	I/O	
52	MVCI	I (S)	Clock input from an external VCO (Fixed at "L")
53	ASYO	O	Playback EFM duplex signal output
54	ASYI	I (A)	Playback EFM comparator slice level input
55	AVDD	—	+3V power supply (Analog)
56	BIAS	I (A)	Playback EFM comparator bias current input
57	RFI	I (A)	Playback EFM RF signal input
58	AVSS	—	Ground (Analog)
59	PCO	O (3)	Phase comparison output for the recording/playback EFM master PLL
60	FILI	I (A)	Filter input for the recording/playback EFM master PLL
61	FILO	O (A)	Filter output for the recording/playback EFM master PLL
62	CLTV	I (A)	Internal VCO control voltage input for the recording/playback EFM master PLL
63	PEAK	I (A)	Light amount signal peak hold input from the CXA2523R
64	BOTM	I (A)	Light amount signal bottom hold input from the CXA2523R
65	ABCD	I (A)	Light amount signal input from the CXA2523R
66	FE	I (A)	Focus error signal input from the CXA2523R
67	AUX1	I (A)	Auxiliary A/D input
68	VC	I (A)	Middle point voltage (+1.5V) input from the CXA2523R
69	ADIO	O (A)	Monitor output of the A/D converter input signal (Not used)
70	AVDD	—	+3V power supply (Analog)
71	ADRT	I (A)	A/D converter operational range upper limit voltage input (Fixed at "H")
72	ADRB	I (A)	A/D converter operational range lower limit voltage input (Fixed at "L")
73	AVSS	—	Ground (Analog)
74	SE	I (A)	Sled error signal input from the CXA2523R
75	TE	I (A)	Tracking error signal input from the CXA2523R
76	DCHG	I (A)	Connected to +3V power supply
77	APC	I (A)	Error signal input for the laser digital APC (Fixed at "L")
78	ADFG	I (S)	ADIP duplex FM signal input from the CXA2523R (22.05 ± 1 kHz)
79	F0CNT	O	Filter f <sub>0</sub> control output to the CXA2523R
80	XLRF	O	Control latch output to the CXA2523R
81	CKRF	O	Control clock output to the CXA2523R
82	DTRF	O	Control data output to the CXA2523R
83	APCREF	O	Reference PWM output for the laser APC
84	TEST0	O	PWM output for the laser digital APC (Not used)
85	TRDR	O	Tracking servo drive PWM output (-)

- Abbreviation

EFM: Eight to Fourteen Modulation

PLL : Phase Locked Loop

VCO: Voltage Controlled Oscillator

Pin No.	Pin Name	I/O	Function
86	TFDR	O	Tracking servo drive PWM output (+)
87	DVDD	—	+3V power supply (Digital)
88	FFDR	O	Focus servo drive PWM output (+)
89	FRDR	O	Focus servo drive PWM output (-)
90	FS4	O	176.4 kHz clock signal output (X'tal) (Not used)
91	SRDR	O	Sled servo drive PWM output (-)
92	SFDR	O	Sled servo drive PWM output (+)
93	SPRD	O	Spindle servo drive PWM output (-)
94	SPFD	O	Spindle servo drive PWM output (+)
95	FGIN	I (S)	Test input (Fixed at "L")
96 to 98	TEST1 to TEST3	I	
99	DVSS	—	Ground (Digital)
100	EFMO	O	EFM output when recording

- Abbreviation

EFM: Eight to Fourteen Modulation

• IC307 A/D, D/A converter (CXD8607N)

Pin No.	Pin Name	I/O	Function
1	INRP	I	Rch analog (+) input
2	INRM	I	Rch analog (-) input
3	REFI	I	A/D reference voltage input (+3.2V)
4	AVDD	—	+5V power supply (A/D, analog)
5	AVSS	—	Ground (A/D, analog)
6	APD	I	A/D analog block power down “L”: Power down
7	NU	—	Not used
8	NU	—	
9	TEST1	I	Test pin (Fixed at “L”)
10	LRCK1	I	A/D LRCK input
11	BCK1	I	A/D BCK input
12	ADDT	O	A/D data output
13	V35A	—	+3.3V power supply
14	VSS1 (LF)	—	Ground (A/D, digital)
15	MCKI	I	A/D master clock input (256 fs)
16	DPD	I	A/D digital block power down “L”: Power down/reset
17	VSS2 (LF)	—	Ground (D/A, digital)
18	INIT	I	D/A initialize “L”: Initialize
19	MODE	I	Mode flag input
20	SHIFT	I	Shift clock input
21	LATCH	I	Latch clock input
22	256CK	O	256 fs clock output
23	V35D	—	+3.3V power supply
24	VSS2	—	Ground (D/A, digital)
25	512CK	O	512 fs clock output
26	BCK2	I	D/A BCK input
27	DADT	I	D/A data input
28	LRCK2	I	D/A LRCK input
29	VDD2	—	+5V power supply (D/A, digital)
30	R1	O	Rch PLM output 1
31	AVDDR	—	+5V power supply (D/A, Rch, analog)
32	R2	O	Rch PLM output 2
33	AVSSR	—	Ground (D/A, Rch, analog)
34	XVDD	—	+5V power supply (X’tal)
35	XOUT	O	X’tal oscillation output (22 MHz)
36	XIN	I	X’tal oscillation input (512 fs ) (22 MHz)
37	XVSS	—	Ground (X’tal)
38	AVSSL	—	Ground (D/A, Lch, analog)
39	L2	O	Lch PLM output 2
40	AVDDL	—	+5V power supply (D/A, Lch, analog)

Pin No.	Pin Name	I/O	Function
41	L1	O	Lch PLM output 1
42	VDD2	—	+5V power supply (D/A, digital)
43	VDD1	—	+5V power supply (A/D, digital)
44	VDD1	—	
45	VSS1	—	Ground (A/D, digital)
46	TEST2	I	Test pin (Fixed at “L”)
47	TEST3	I	
48	VSS1 (LF)	—	Ground (A/D, digital)
49	NU	—	Not used
50	NU	—	
51	AVSS (LF)	—	Ground (A/D, analog)
52	LVDD	—	+5V power supply (A/D, buffer)
53	LVSS	—	Ground (A/D, buffer)
54	REFO	O	A/D reference voltage output (+3.2V)
55	INLM	I	Lch analog (-) input
56	INLP	I	Lch analog (+) input



• IC501 System Control (M30610MCA-251FP)

Pin No.	Pin Name	I/O	Function
1, 2	NC	O	Not used (Fixed at "L")
3	C1ER	O	C1 error rate voltage output (Fixed at "L")
4	ADER	O	AD error rate voltage output (Fixed at "L")
5	SQSY	I	ADIP sync or subcode Q sync input from CXD2654R
6	RMC	I	Remote controls
7	NC	O	Not used (Fixed at "L")
8	BYTE	I	Data bus changed input (Fixed at "L")
9	CNVSS	—	Ground
10	XIN-T	O	Not used (Fixed at "L")
11	XOUT-T	O	Not used (Fixed at "L")
12	S.RST	I	System rest input
13	XOUT	O	Main clock output (7.0MHz)
14	VSS	—	Ground
15	XIN	I	Main clock input (7.0MHz)
16	+3.3V	—	+3.3V power supply
17	NMI	I	(Fixed at "H")
18	DQSY	I	Digital in sync input
19	P.DOWN	I	Power down detection input "L": Power down
20	XINT	I	Interrupt status input from CXD2654R
21, 22	JOG1, JOG0	I	JOG dial pulse input from the rotary encoder
23 to 30	NC	O	Not used
31	SWDT	O	Writing data signal output to the serial bus
32	SRDT	I	Reading data signal input from the serial bus
33	SCLK	O	Clock signal output to the serial bus
34	FLCS	O	Chip select signal output to the display driver
35	FLDATA	O	Serial data signal output to the display driver
36	NC	O	Not used (Fixed at "L")
37	FLCLK	O	Serial clock signal output to the display driver
38 to 45	NC	O	Not used
46	LOADING SEL: L	I	Loading control system select signal input (Fixed at "L")
47	NC	O	Not used (Fixed at "L")
48	DA.RST	O	Reset signal output to the D/A, A/D converter Reset: "L"
49	MUTE	O	DA line out muting output Mute: "L"
50	STB	O	Strobe signal output to the power supply circuit Power supply ON: "H", stand by: "L"
51	CHACK IN	I	Detection input from the chucking-in switch "L": Chucking
52	PACK-IN	I	Detection input from the disc detection switch (Fixed at "L")
53	PACK-OUT	I	Detection input from the loading out switch. Loaded out position: "L", Others: "H"
54	LDIN	I	Loading motor control input
55	LDOUT	O	Loading motor control output
56	LD-LOW	O	Loading motor voltage control output Low voltage: "H"
57, 58	NC	O	Not used (Fixed at "L")
59	REC-P	I	Detection signal input from the recording position detection switch
60	PB-P	I	Detection signal input from the playback position detection switch
61	REC/PB	O	Operation mode output Write: "H"
62	+3.3V	—	+3.3V power supply

Pin No.	Pin Name	I/O	Function
63	NC	O	Not used (Fixed at "L")
64	GND	—	Ground
65	SDA	I/O	Data signal input/output pin with the backup memory
66	MNT3 (SLOCK)	I	In the state of spindle srvo lock from the CXD2564R
67	WR PWR	O	Write power ON/OFF output
68	PROTECT	I	Recording-protection claw detection input from the protection detection switch Protect: "H"
69	REFLECT	I	Disk reflection rate detection input from the reflect detection switch Disk with low reflection rate: "H"
70	LDON	O	Laser ON/OFF control output "H": Laser ON
71	SENS	I	Internal status (SENSE) input from the CXD2654R
72	NMT1 (SHOCK)	I	Track jump signal input from the CXD2654R
73	DIG-RST	O	Digital rest signal output to the CXD2654R and motor driver Reset: "L"
74	MNT2 (XBUSY)	I	In the state of executive command from the CXD2654R
75	XLATCH	O	Latch signal output to the serial bus
76	MOD	O	Laser modulation switching signal output
77	LIMIT-IN	I	Detection input from the limit switch Sled limit-In: "L"
78	MNT0 (FOK)	I	Focus OK signal input from the CXD26504R "H" is input when focus is on
79	SCL	O	Clock signal output to the backup memory
80	SCTX	O	Writing data transmission timing output to the CXD2654R Shared with the magnetic head ON/OFF output
81	CLKSET0	I	Clock destination select pin US, Canadian: "L", Except US, Canadian : "H"
82	CLKSET1	I	Clock destination select pin US, Canadian: "H", Except US, Canadian : "L"
83	LED0	O	Not used
84	LED1	O	
85	NC	O	
86	OPT SEL	O	
87,88	NC	O	
89	SOURCE	I	
90	NC	O	Not used
91	TIMER	I	Timer mode change input (A/D input)
92	NC	O	Not used
93 to 95	KEY 3 to KEY 1	I	Key input pin (A/D input)
96	AVSS	—	Ground (Analog)
97	KEY0	I	Key input pin (A/D input)
98	VREF	—	A/D reference voltage (Fixed at "H")
99	+3.3V	—	+3.3V power supply
100	MONO/ST	I	Monaural, stereo change input Monaural: "H"

# SECTION 7 EXPLODED VIEWS

**NOTE:**

- -XX, -X mean standardized parts, so they may have some difference from the original one.
- Items marked "\*" are not stocked since they are seldom required for routine service. Some delay should be anticipated when ordering these items.
- Color Indication of Appearance Parts Example:  
KNOB, BALANCE (WHITE)

↑  
Cabinets color

- The mechanical parts with no reference number in the exploded views are not supplied.
- Hardware (# mark) list and accessories and packing materials are given in the last of this parts list.
- Abbreviation  
CND : Canadian model  
HK : Hong Kong model  
SP : Singapore model  
AUS : Australian model

The components identified by mark  $\triangle$  or dotted line with mark  $\triangle$  are critical for safety.  
Replace only with part number specified.

Les composants identifiés par une marque  $\triangle$  sont critiques pour la sécurité.  
Ne les remplacer que par une pièce portant le numéro spécifié.

## 7-1. CASE AND BACK PANEL SECTION

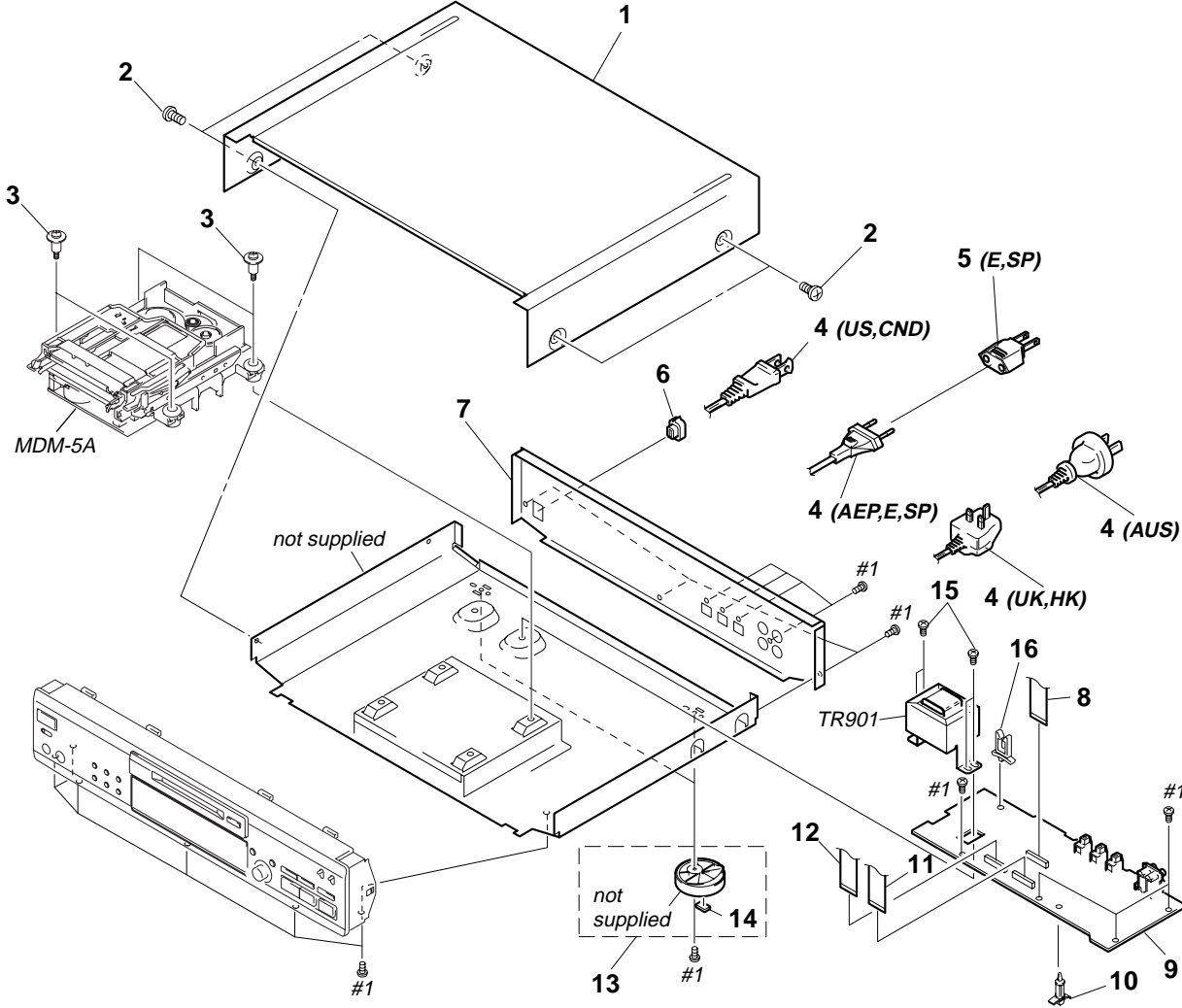

Ref. No.	Part No.	Description	Remark	Ref. No.	Part No.	Description	Remark
* 1	4-983-661-01	CASE (408226)(BLACK)		* 7	4-998-210-61	PANEL, BACK (E,SP)	
* 1	4-983-661-41	CASE (408226)(SILVER)		* 7	4-998-210-71	PANEL, BACK (HK)	
2	3-363-099-11	SCREW (CASE 3 TP2)(SILVER)		8	1-783-138-11	WIRE (FLAT TYPE)(19 CORE)	
2	3-704-366-01	SCREW (CASE)(M3X8)(BLACK)		* 9	A-4699-922-A	MAIN BOARD, COMPLETE (US,CND)	
3	4-999-839-01	SCREW, STEP		* 9	A-4699-927-A	MAIN BOARD, COMPLETE (E,SP)	
$\triangle$ 4	1-558-945-21	CORD, POWER (POLAR.SPT-1)(US,CND)		* 9	A-4699-932-A	MAIN BOARD, COMPLETE (AEP,UK,HK,AUS)	
$\triangle$ 4	1-696-586-21	CORD, POWER (UK,HK)		* 10	4-954-051-51	HOLDER, PC BOARD	
$\triangle$ 4	1-696-846-21	CORD, POWER (AUS)		11	1-783-140-11	WIRE (FLAT TYPE)(23 CORE)	
$\triangle$ 4	1-751-275-11	CORD, POWER (AEP,E,SP)		12	1-783-139-11	WIRE (FLAT TYPE)(21 CORE)	
$\triangle$ 5	1-569-008-11	ADAPTOR, CONVERSION 2P (E,SP)		13	X-4947-389-1	FOOT ASSY (F50150S)(BLACK)	
6	3-703-244-00	BUSHING (2104), CORD (AEP,UK,E,SP,HK,AUS)		13	X-4947-748-1	FOOT ASSY (F50150S)(SILVER)	
6	3-703-571-11	BUSHING (S)(4516), CORD (US,CND)		14	4-983-762-02	CUSHION	
* 7	4-996-697-31	PANEL, BACK (US)		15	4-886-821-11	SCREW, S TIGHT, +PTTWX 3X6	
* 7	4-996-697-41	PANEL, BACK (CND)		* 16	3-644-407-00	CLIP, AC WIRE E	
* 7	4-998-210-01	PANEL, BACK (AEP)		$\triangle$ TR901	1-431-684-11	TRANSFORMER, POWER (E,SP)	
* 7	4-998-210-11	PANEL, BACK (UK)		$\triangle$ TR901	1-431-685-11	TRANSFORMER, POWER (AEP,UK,HK,AUS)	
* 7	4-998-210-51	PANEL, BACK (AUS)		$\triangle$ TR901	1-431-686-11	TRANSFORMER, POWER (US,CND)	

## 7-2. FRONT PANEL SECTION

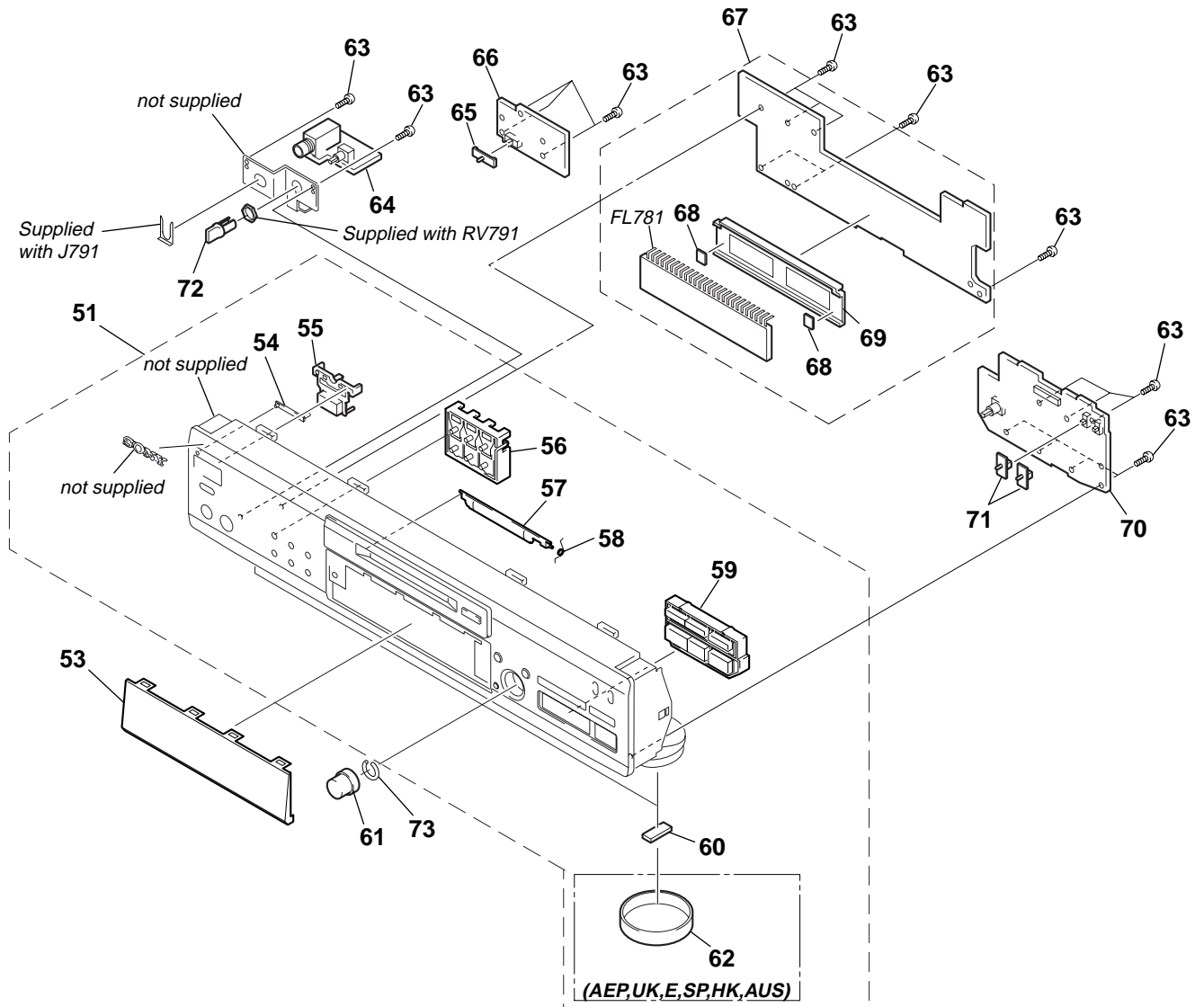

Ref. No.	Part No.	Description	Remark	Ref. No.	Part No.	Description	Remark
51	X-4949-367-1	PANEL ASSY, FRONT (US,CND)		* 64	1-668-240-11	HP BOARD	
51	X-4949-609-1	PANEL ASSY, FRONT (BLACK)(EXCEPT US,CND)		65	3-917-216-02	KNOB (TIMER)(SILVER)	
51	X-4949-610-1	PANEL ASSY, FRONT (SILVER)(EXCEPT US,CND)		65	3-917-216-11	KNOB (TIMER)(BLACK)	
53	4-996-691-11	WINDOW (FL)		* 66	1-668-239-11	POWER SW BOARD	
54	4-996-682-11	INDICATOR		* 67	A-4699-924-A	DISPLAY BOARD, COMPLETE (US,CND)	
				* 67	A-4699-929-A	DISPLAY BOARD, COMPLETE (E,SP)	
55	4-996-683-21	BUTTON (POWER)(BLACK)		* 67	A-4699-934-A	DISPLAY BOARD, COMPLETE (AEP,UK,HK,AUS)	
55	4-996-683-31	BUTTON (POWER)(SILVER)		68	2-389-320-01	CUSHION	
56	4-996-684-21	BUTTON (SUB)(BLACK)		69	4-996-686-01	HOLDER (FL)(US,CND)	
56	4-996-684-31	BUTTON (SUB)(SILVER)		69	4-996-686-11	HOLDER (FL)(AEP,UK,E,SP,HK,AUS)	
57	4-996-690-21	LID (CARTRIDGE)(BLACK)		* 70	A-4699-923-A	KEY SW BOARD, COMPLETE (US,CND)	
				* 70	A-4699-928-A	KEY SW BOARD, COMPLETE (E,SP)	
57	4-996-690-31	LID (CARTRIDGE)(SILVER)		* 70	A-4699-933-A	KEY SW BOARD, COMPLETE (AEP,UK,HK,AUS)	
58	4-976-593-01	SPRING (LID), TORSION		71	4-996-312-11	KNOB (TIMER)(BLACK)	
59	4-996-689-21	BUTTON (MAIN)(BLACK)		71	4-996-312-21	KNOB (TIMER)(SILVER)	
59	4-996-689-31	BUTTON (MAIN)(SILVER)		72	4-950-189-01	KNOB (A)(VOL)(BLACK)	
60	4-983-762-02	CUSHION					
				72	4-950-189-31	KNOB (A)(VOL)(SILVER)	
61	4-996-687-51	KNOB (AMS)(BLACK)		73	3-354-981-01	SPRING (SUS), RING	
61	4-996-687-61	KNOB (AMS)(SILVER)		FL781	1-517-738-11	INDICATOR TUBE, FLUORESCENT	
62	4-981-435-11	RING (DIA. 50), ORNAMENTAL (AEP,UK,E,SP,HK,AUS)					
63	4-951-620-01	SCREW (2.6X8), +BVTP					

### 7-3. MECHANISM SECTION (MDM-5A)

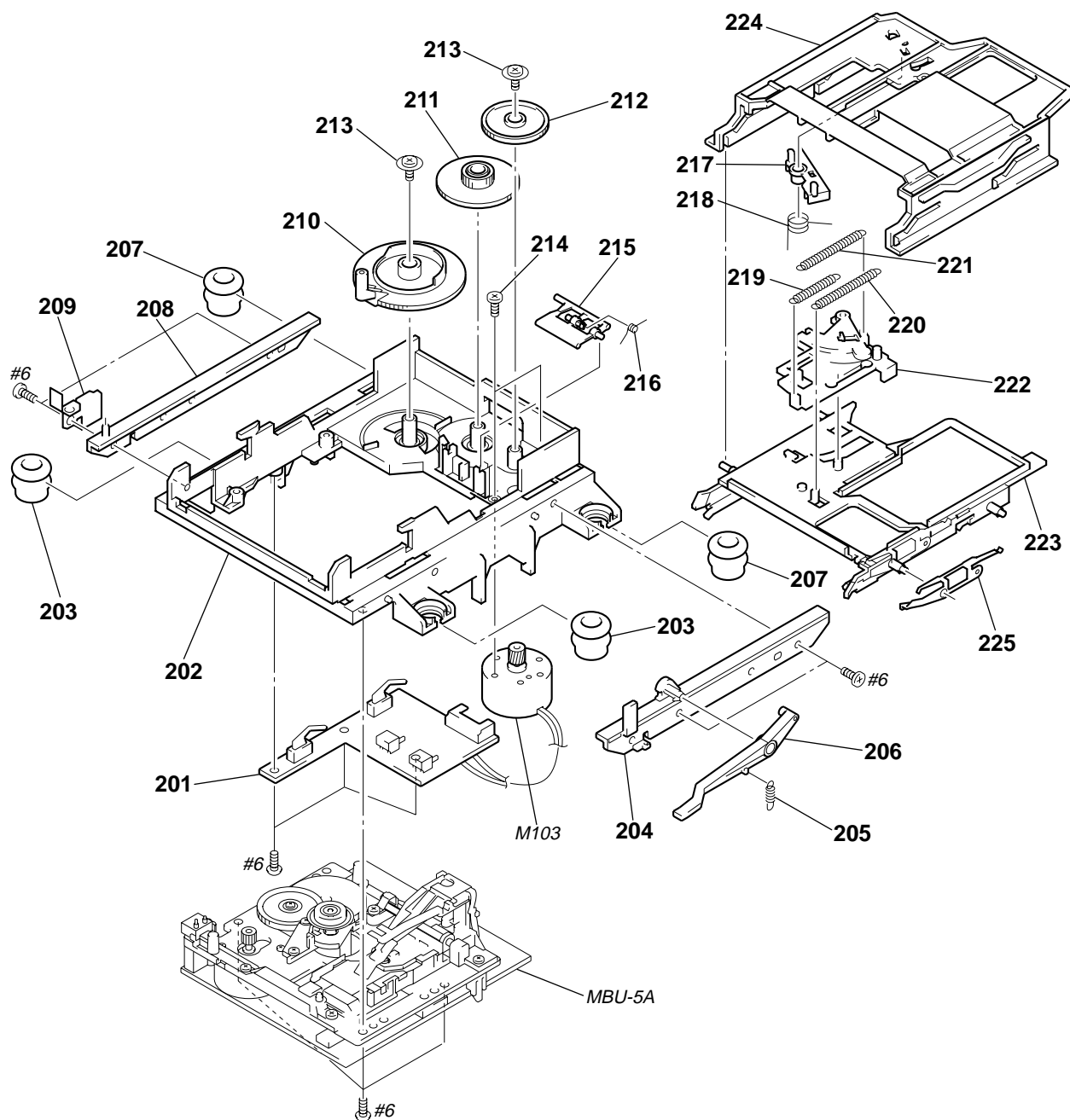

Ref. No.	Part No.	Description	Remark	Ref. No.	Part No.	Description	Remark
* 201	1-668-111-11	SW BOARD		215	4-996-227-01	LEVER (HEAD)	
* 202	4-996-217-01	CHASSIS		216	4-996-229-01	SPRING (HEAD LEVER), TORSION	
203	4-996-223-01	INSULATOR (F)(BLACK)		217	4-996-212-01	LEVER (LIMITER)	
* 204	4-996-218-01	BRACKET (GUIDE R)		218	4-996-213-01	SPRING (LIMITER), TORSION	
205	4-996-277-01	SPRING (O/C), TENSION		219	4-996-214-01	SPRING (SLIDER), TENSION	
206	4-996-226-01	LEVER (O/C)		220	4-996-216-01	SPRING (HOLDER), TENSION	
207	4-999-347-01	INSULATOR (R)(GREEN)		221	4-210-396-01	SPRING (LOCK), TENSION	
* 208	4-996-225-01	BRACKET (GUIDE L)		222	X-4949-246-1	SLIDER ASSY	
209	4-988-466-21	SPRING (ELECTROSTATIC), LEAF		* 223	X-4949-245-1	HOLDER ASSY	
210	4-996-219-01	GEAR (CAM GEAR)		* 224	4-996-211-01	SLIDER (CAM)	
211	4-996-220-01	GEAR (A)		225	4-998-763-01	SPRING (SHUTTER), LEAF	
212	4-996-221-01	GEAR (B)					
213	4-933-134-01	SCREW (+PTPWH M2.6X6)		M103	X-4949-264-1	MOTOR ASSY, LOADING	
214	4-996-224-01	SCREW (1.7X4), +PWH					

7-4. BASE UNIT SECTION (MBU-5A)

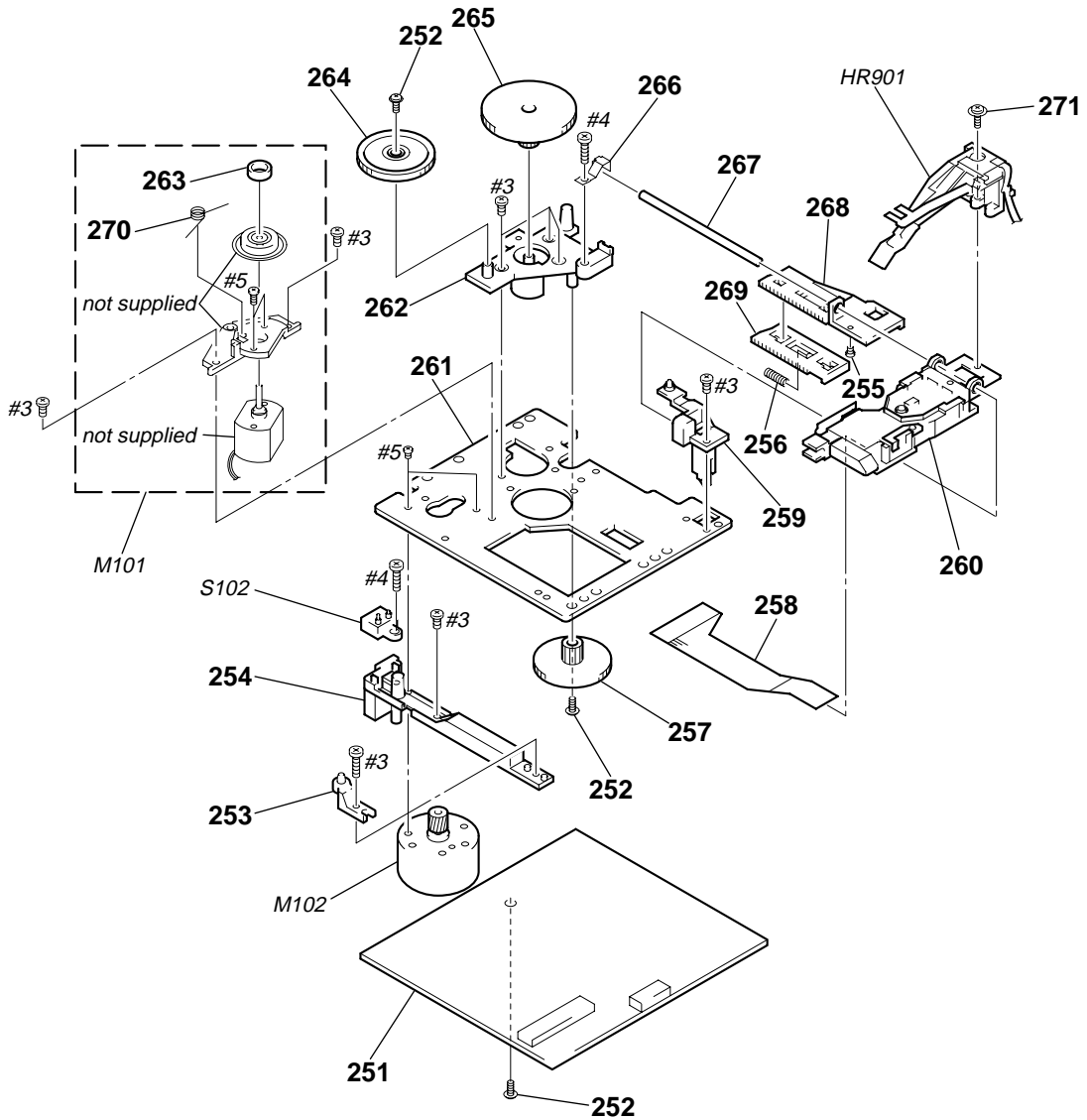

<p>The components identified by mark <math>\triangle</math> or dotted line with mark <math>\triangle</math> are critical for safety. Replace only with part number specified.</p>	<p>Les composants identifiés par une marque <math>\triangle</math> sont critiques pour la sécurité. Ne les remplacer que par une pièce portant le numéro spécifié.</p>
---	--

Ref. No.	Part No.	Description	Remark	Ref. No.	Part No.	Description	Remark
* 251	A-4699-893-A	BD BOARD, COMPLETE		264	4-996-260-01	GEAR (SL-A)	
252	3-372-761-01	SCREW (M1.7X4), TAPPING		265	4-996-261-01	GEAR (SL-B)	
* 253	4-996-267-01	BASE (BU-D)		266	4-996-264-01	SPRING (SHAFT), LEAF	
* 254	4-996-255-01	BASE (BU-C)		267	4-996-265-01	SHAFT (OP)	
255	4-900-590-01	SCREW, PRECISION SMALL		268	4-996-256-01	BASE, SL	
256	4-996-258-01	SPRING (SL), COMPRESSION		269	4-996-257-01	RACK (SL)	
257	4-996-262-01	GEAR (SL-C)		270	4-996-263-01	SPRING (SPDL), TORSION	
258	1-667-954-11	FLEXIBLE BOARD		271	4-988-560-01	SCREW (+P 1.7X6)	
* 259	4-996-253-01	BASE (BU-A)		HR901	1-500-502-11	HEAD, OVER WRITE	
$\triangle$ 260	8-583-028-02	OPTICAL PICK-UP KMS-260A/J1N		M101	A-4672-475-A	MOTOR ASSY, SPINDLE	
* 261	4-996-252-01	CHASSIS, BU		M102	A-4672-474-A	MOTOR ASSY, SLED	
* 262	4-996-254-01	BASE (BU-B)		S102	1-762-148-21	SWITCH, PUSH (REFLECT/PROTECT)	
263	4-967-688-11	MAGNET, ABSORPTION					



## SECTION 8 ELECTRICAL PARTS LIST

## Note:

The components identified by mark  $\Delta$  or dotted line with mark  $\Delta$  are critical for safety.

Replace only with part number specified.

Les composants identifiés par une marque  $\Delta$  sont critiques pour la sécurité.

Ne les remplacer que par une pièce portant le numéro spécifié.

When indicating parts by reference number, please include the board name.

• Due to standardization, replacements in the parts list may be different from the parts specified in the diagrams or the components used on the set.

• -XX, -X mean standardized parts, so they may have some difference from the original one.

• Items marked “\*” are not stocked since they are seldom required for routine service. Some delay should be anticipated when ordering these items.

### RESISTORS

All resistors are in ohms

METAL: Metal-film resistor

METAL OXIDE: Metal Oxide-film resistor

F : nonflammable

### SEMICONDUCTORS

In each case, u:  $\mu$ , for example:

uA...:  $\mu$  A..., uPA...:  $\mu$  PA..., uPB...:  $\mu$  PB...,

uPC...:  $\mu$  PC..., uPD...:  $\mu$  PD...

### CAPACITORS

uF :  $\mu$  F

### COILS

uH :  $\mu$  H

### Abbreviation

CND : Canadian model

HK : Hong Kong model

AUS : Australian model

SP : Singapore model

Ref. No.	Part No.	Description	Remark	Ref. No.	Part No.	Description	Remark
	A-4699-893-A	BD MOUNTED BOARD, COMPLETE *****		C163	1-164-232-11	CERAMIC CHIP 0.01uF	50V
		< CAPACITOR >		C164	1-164-232-11	CERAMIC CHIP 0.01uF	50V
C101	1-125-822-21	TANTALUM 10uF 20%	10V	C167	1-163-038-91	CERAMIC CHIP 0.1uF	25V
C102	1-163-038-91	CERAMIC CHIP 0.1uF	25V	C168	1-163-038-91	CERAMIC CHIP 0.1uF	25V
C103	1-125-822-21	TANTALUM 10uF 20%	10V	C169	1-125-822-21	TANTALUM 10uF 20%	10V
C104	1-125-822-21	TANTALUM 10uF 20%	10V	C171	1-163-038-91	CERAMIC CHIP 0.1uF	25V
C105	1-164-232-11	CERAMIC CHIP 0.01uF	50V	C181	1-104-913-11	TANTAL. CHIP 100uF 20%	16V
C106	1-163-275-11	CERAMIC CHIP 0.001uF 5%	50V	C183	1-163-038-91	CERAMIC CHIP 0.1uF	25V
C107	1-163-038-91	CERAMIC CHIP 0.1uF	25V	C184	1-117-970-11	ELECT CHIP 22uF 20%	10V
C108	1-163-038-91	CERAMIC CHIP 0.1uF	25V	C185	1-164-611-11	CERAMIC CHIP 0.001uF 10%	500V
C109	1-163-037-11	CERAMIC CHIP 0.022uF 10%	25V	C187	1-104-913-11	TANTAL. CHIP 100uF 20%	16V
C111	1-164-344-11	CERAMIC CHIP 0.068uF 10%	25V	C188	1-164-232-11	CERAMIC CHIP 0.01uF	50V
C112	1-163-017-00	CERAMIC CHIP 0.0047uF 5%	50V	C189	1-163-989-11	CERAMIC CHIP 0.033uF 10%	25V
C113	1-109-982-11	CERAMIC CHIP 1uF 10%	10V	C190	1-126-206-11	ELECT CHIP 100uF 20%	6.3V
C115	1-164-489-11	CERAMIC CHIP 0.22uF 10%	16V	C191	1-163-038-91	CERAMIC CHIP 0.1uF	25V
C116	1-163-037-11	CERAMIC CHIP 0.022uF 10%	25V	C196	1-163-038-91	CERAMIC CHIP 0.1uF	25V
C117	1-163-809-11	CERAMIC CHIP 0.047uF 10%	25V	C197	1-163-038-91	CERAMIC CHIP 0.1uF	25V
C118	1-163-038-91	CERAMIC CHIP 0.1uF	25V			< CONNECTOR >	
C119	1-125-822-21	TANTALUM 10uF 20%	10V	CN101	1-569-479-21	CONNECTOR, FPC 21P	
C121	1-125-822-21	TANTALUM 10uF 20%	10V	CN102	1-784-833-21	CONNECTOR (SMD) 21P	
C122	1-164-232-11	CERAMIC CHIP 0.01uF	50V	CN103	1-784-834-21	CONNECTOR (SMD) 23P	
C123	1-163-038-91	CERAMIC CHIP 0.1uF	25V	CN104	1-770-687-11	CONNECTOR, FFC/FPC 4P	
C124	1-163-038-91	CERAMIC CHIP 0.1uF	25V	CN110	1-695-440-21	PIN, CONNECTOR (PC BOARD) 6P	
C127	1-163-038-91	CERAMIC CHIP 0.1uF	25V			< DIODE >	
C128	1-164-232-11	CERAMIC CHIP 0.01uF	50V	D101	8-719-988-62	DIODE 1SS355	
C129	1-107-823-11	CERAMIC CHIP 0.47uF 10%	16V	D181	8-719-046-86	DIODE F1J6TP	
C130	1-163-251-11	CERAMIC CHIP 100PF 5%	50V	D183	8-719-046-86	DIODE F1J6TP	
C131	1-163-023-00	CERAMIC CHIP 0.015uF 5%	50V			< IC >	
C132	1-107-823-11	CERAMIC CHIP 0.47uF 10%	16V	IC101	8-752-080-95	IC CXA2523AR	
C133	1-164-161-11	CERAMIC CHIP 0.0022uF 10%	100V	IC103	8-729-903-10	IC TRANSISTOR FMW1	
C134	1-163-038-91	CERAMIC CHIP 0.1uF	25V	IC121	8-752-389-44	IC CXD2654R	
C135	1-163-038-91	CERAMIC CHIP 0.1uF	25V	IC123	8-759-096-87	IC TC7WU04FU(TE12R)	
C136	1-126-206-11	ELECT CHIP 100uF 20%	6.3V	IC124	8-759-334-38	IC MSM51V4400-70TS-K	
C142	1-163-251-11	CERAMIC CHIP 100PF 5%	50V	IC152	8-759-430-25	IC BH6511FS-E2	
C143	1-163-251-11	CERAMIC CHIP 100PF 5%	50V	IC171	8-759-487-04	IC BR24C02F-E2	
C144	1-163-251-11	CERAMIC CHIP 100PF 5%	50V	IC181	8-759-481-17	IC MC74ACT08DTR2	
C146	1-163-038-91	CERAMIC CHIP 0.1uF	25V	IC192	8-759-460-72	IC BA033FP-E2	
C151	1-126-206-11	ELECT CHIP 100uF 20%	6.3V			< COIL >	
C152	1-163-038-91	CERAMIC CHIP 0.1uF	25V	L101	1-414-813-11	INDUCTOR 0uH	
C153	1-164-232-11	CERAMIC CHIP 0.01uF	50V	L102	1-414-813-11	INDUCTOR 0uH	
C156	1-163-038-91	CERAMIC CHIP 0.1uF	25V	L103	1-414-813-11	INDUCTOR 0uH	
C158	1-163-019-00	CERAMIC CHIP 0.0068uF 10%	50V	L105	1-414-813-11	INDUCTOR 0uH	
C160	1-104-601-11	ELECT CHIP 10uF 20%	10V	L106	1-414-813-11	INDUCTOR 0uH	
C161	1-104-601-11	ELECT CHIP 10uF 20%	10V				

Ref. No.	Part No.	Description	Remark	Ref. No.	Part No.	Description	Remark
L121	1-414-813-11	INDUCTOR 0uH		R151	1-216-073-00	METAL CHIP 10K 5%	1/10W
L122	1-414-813-11	INDUCTOR 0uH		R152	1-216-073-00	METAL CHIP 10K 5%	1/10W
L151	1-412-029-11	INDUCTOR CHIP 10uH		R158	1-216-097-91	RES,CHIP 100K 5%	1/10W
L152	1-412-029-11	INDUCTOR CHIP 10uH		R159	1-216-097-91	RES,CHIP 100K 5%	1/10W
L153	1-412-032-11	INDUCTOR CHIP 100uH					
L154	1-412-032-11	INDUCTOR CHIP 100uH		R160	1-216-295-91	SHORT 0	
L161	1-414-813-11	INDUCTOR 0uH		R161	1-216-057-00	METAL CHIP 2.2K 5%	1/10W
L162	1-414-813-11	INDUCTOR 0uH		R162	1-216-057-00	METAL CHIP 2.2K 5%	1/10W
L181	1-216-295-91	SHORT 0		R163	1-216-057-00	METAL CHIP 2.2K 5%	1/10W
		< TRANSISTOR >		R164	1-216-045-00	METAL CHIP 680 5%	1/10W
Q101	8-729-403-35	TRANSISTOR UN5113		R165	1-216-097-91	RES,CHIP 100K 5%	1/10W
Q102	8-729-026-53	TRANSISTOR 2SA1576A-T106-QR		R166	1-220-149-11	REGISTER 2.2 10%	1/2W
Q103	8-729-028-99	TRANSISTOR RN1307-TE85L		R167	1-216-065-91	RES,CHIP 4.7K 5%	1/10W
Q104	8-729-028-99	TRANSISTOR RN1307-TE85L		R169	1-219-724-11	METAL CHIP 1 1%	1/4W
Q162	8-729-101-07	TRANSISTOR 2SB798-DL		R170	1-216-073-00	METAL CHIP 10K 5%	1/10W
Q163	8-729-403-35	TRANSISTOR UN5113		R171	1-216-073-00	METAL CHIP 10K 5%	1/10W
Q181	8-729-018-75	TRANSISTOR 2SJ278MY		R173	1-216-121-91	RES,CHIP 1M 5%	1/10W
Q182	8-729-017-65	TRANSISTOR 2SK1764KY		R175	1-216-065-91	RES,CHIP 4.7K 5%	1/10W
		< RESISTOR >		R177	1-216-061-00	METAL CHIP 3.3K 5%	1/10W
R103	1-216-049-91	RES,CHIP 1K 5%	1/10W	R179	1-216-085-00	METAL CHIP 33K 5%	1/10W
R104	1-216-073-00	METAL CHIP 10K 5%	1/10W	R180	1-216-073-00	METAL CHIP 10K 5%	1/10W
R105	1-216-065-91	RES,CHIP 4.7K 5%	1/10W	R182	1-216-089-91	RES,CHIP 47K 5%	1/10W
R106	1-216-133-00	METAL CHIP 3.3M 5%	1/10W	R183	1-216-089-91	RES,CHIP 47K 5%	1/10W
R107	1-216-113-00	METAL CHIP 470K 5%	1/10W	R184	1-216-073-00	METAL CHIP 10K 5%	1/10W
R109	1-216-295-91	SHORT 0		R185	1-216-081-00	METAL CHIP 22K 5%	1/10W
R110	1-216-073-00	METAL CHIP 10K 5%	1/10W	R186	1-216-089-91	RES,CHIP 47K 5%	1/10W
R111	1-216-295-91	SHORT 0		R188	1-216-073-00	METAL CHIP 10K 5%	1/10W
R112	1-216-089-91	RES,CHIP 47K 5%	1/10W	R189	1-216-073-00	METAL CHIP 10K 5%	1/10W
R113	1-216-049-91	RES,CHIP 1K 5%	1/10W	R190	1-216-073-00	METAL CHIP 10K 5%	1/10W
R115	1-216-049-91	RES,CHIP 1K 5%	1/10W	R195	1-216-073-00	METAL CHIP 10K 5%	1/10W
R117	1-216-113-00	METAL CHIP 470K 5%	1/10W	R196	1-216-295-91	SHORT 0	
R120	1-216-025-91	RES,CHIP 100 5%	1/10W	R197	1-216-295-91	SHORT 0	
R121	1-216-097-91	RES,CHIP 100K 5%	1/10W			< SWITCH >	
R123	1-216-033-00	METAL CHIP 220 5%	1/10W	S101	1-762-596-21	SWITCH, PUSH (1 KEY)(LIMIT IN)	
R124	1-216-025-91	RES,CHIP 100 5%	1/10W	S102	1-762-148-21	SWITCH, SLIDE (REFLECT/PROTECT)	
R125	1-216-025-91	RES,CHIP 100 5%	1/10W			*****	
R127	1-216-025-91	RES,CHIP 100 5%	1/10W	*	A-4699-924-A	DISPLAY BOARD, COMPLETE (US,CND)	*****
R129	1-216-295-91	SHORT 0		*	A-4699-929-A	DISPLAY BOARD, COMPLETE (E,SP)	*****
R131	1-216-073-00	METAL CHIP 10K 5%	1/10W	*	A-4699-934-A	DISPLAY BOARD, COMPLETE (AEP,UK,HK,AUS)	*****
R132	1-216-097-91	RES,CHIP 100K 5%	1/10W	*	4-996-686-11	HOLDER (FL)	
R133	1-216-117-00	METAL CHIP 680K 5%	1/10W		7-685-872-09	SCREW +BVTT 3X8 (S)	
R134	1-216-049-91	RES,CHIP 1K 5%	1/10W			< CAPACITOR >	
R135	1-216-061-00	METAL CHIP 3.3K 5%	1/10W	C701	1-126-153-11	ELECT 22uF 20%	6.3V
R136	1-216-049-91	RES,CHIP 1K 5%	1/10W	C761	1-124-584-00	ELECT 100uF 20%	10V
R137	1-216-295-91	SHORT 0		C762	1-162-306-11	CERAMIC 0.01uF 20%	16V
R140	1-216-029-00	METAL CHIP 150 5%	1/10W	C770	1-164-159-11	CERAMIC 0.1uF	50V
R142	1-216-073-00	METAL CHIP 10K 5%	1/10W	C772	1-162-213-31	CERAMIC 39PF 5%	50V
R143	1-216-073-00	METAL CHIP 10K 5%	1/10W	C773	1-162-306-11	CERAMIC 0.01uF 20%	16V
R144	1-216-025-91	RES,CHIP 100 5%	1/10W	C774	1-162-294-31	CERAMIC 0.001uF 10%	50V
R145	1-216-073-00	METAL CHIP 10K 5%	1/10W	C775	1-162-294-31	CERAMIC 0.001uF 10%	50V
R146	1-216-037-00	METAL CHIP 330 5%	1/10W				
R147	1-216-025-91	RES,CHIP 100 5%	1/10W				
R148	1-216-045-00	METAL CHIP 680 5%	1/10W				
R149	1-216-073-00	METAL CHIP 10K 5%	1/10W				
R150	1-216-295-91	SHORT 0					



<b>DISPLAY</b>	<b>HP</b>	<b>KEY SW</b>
----------------	-----------	---------------

Ref. No.	Part No.	Description	Remark		
C776	1-162-294-31	CERAMIC	0.001uF	10%	50V
C781	1-162-294-31	CERAMIC	0.001uF	10%	50V
C783	1-162-294-31	CERAMIC	0.001uF	10%	50V
< CONNECTOR >					
CN750	1-695-994-11	HOUSING, CONNECTOR 5P			
CN771	1-778-317-11	CONNECTOR, BOARD TO BOARD 13P			
< FLUORESCENT INDICATOR >					
FL781	1-517-738-11	INDICATOR TUBE, FLUORESCENT			
< IC >					
IC761	8-749-013-92	IC GP1UC7X			
IC771	8-759-525-49	IC MSM9201 (AEP,UK,E,SP,HK,AUS)			
< TRANSISTOR >					
Q781	8-729-620-05	TRANSISTOR 2SC2603-EF			
Q782	8-729-620-05	TRANSISTOR 2SC2603-EF			
< RESISTOR >					
R722	1-249-421-11	CARBON	2.2K	5%	1/4W F
R723	1-247-843-11	CARBON	3.3K	5%	1/4W
R724	1-249-425-11	CARBON	4.7K	5%	1/4W F
R725	1-249-429-11	CARBON	10K	5%	1/4W
R726	1-249-435-11	CARBON	33K	5%	1/4W
R732	1-249-421-11	CARBON	2.2K	5%	1/4W F
R761	1-249-401-11	CARBON	47	5%	1/4W F
R762	1-247-807-31	CARBON	100	5%	1/4W
R772	1-247-843-11	CARBON	3.3K	5%	1/4W
R773	1-247-807-31	CARBON	100	5%	1/4W
R774	1-247-807-31	CARBON	100	5%	1/4W
R775	1-247-807-31	CARBON	100	5%	1/4W
R776	1-247-807-31	CARBON	100	5%	1/4W
R781	1-247-807-31	CARBON	100	5%	1/4W
R782	1-249-441-11	CARBON	100K	5%	1/4W
R783	1-247-807-31	CARBON	100	5%	1/4W
R784	1-249-441-11	CARBON	100K	5%	1/4W
< SWITCH >					
S721	1-762-875-21	SWITCH, KEYBOARD (≡ EJECT)			
S722	1-762-875-21	SWITCH, KEYBOARD (PLAY MODE)			
S723	1-762-875-21	SWITCH, KEYBOARD (REPEAT)			
S724	1-762-875-21	SWITCH, KEYBOARD (SCROLL)			
S725	1-762-875-21	SWITCH, KEYBOARD (LEVEL/DISPLAY/CHAR)			
S731	1-762-875-21	SWITCH, KEYBOARD (TIME)			
S732	1-762-875-21	SWITCH, KEYBOARD (FADER)			
*****					
*	1-668-240-11	HP BOARD	*****		
< CAPACITOR >					
C791	1-162-282-31	CERAMIC	100PF	10%	50V
C792	1-162-282-31	CERAMIC	100PF	10%	50V

Ref. No.	Part No.	Description	Remark		
< CONNECTOR >					
* CN791	1-506-468-11	PIN, CONNECTOR 3P			
< JACK >					
J791	1-770-306-11	JACK (LARGE TYPE)(PHONES)			
< RESISTOR >					
R791	1-249-393-11	CARBON	10	5%	1/4W F
R792	1-249-393-11	CARBON	10	5%	1/4W F
< VARIABLE RESISTOR >					
RV791	1-225-329-11	RES, VAR, CARBON 1K/1K (PHONES LEVEL)	(US,CND)		
RV791	1-225-590-11	RES, VAR 1K/1K (PHONE LEVEL)	(AEP,UK,E,SP,HK,AUS)		
*****					
*	A-4699-923-A	KEY SW BOARD, COMPLETE (US,CND)	*****		
*	A-4699-928-A	KEY SW BOARD, COMPLETE (E,SP)	*****		
*	A-4699-933-A	KEY SW BOARD, COMPLETE (AEP,UK,HK,AUS)	*****		
< CAPACITOR >					
C700	1-126-153-11	ELECT	22uF	20%	6.3V
< CONNECTOR >					
CN701	1-778-449-11	CONNECTOR, FFC/FPC 19P			
CN770	1-778-318-11	CONNECTOR, BOARD TO BOARD 13P			
< RESISTOR >					
R702	1-249-421-11	CARBON	2.2K	5%	1/4W F
R703	1-247-843-11	CARBON	3.3K	5%	1/4W
R704	1-249-425-11	CARBON	4.7K	5%	1/4W F
R705	1-249-429-11	CARBON	10K	5%	1/4W
R706	1-249-435-11	CARBON	33K	5%	1/4W
R712	1-249-421-11	CARBON	2.2K	5%	1/4W F
R713	1-247-843-11	CARBON	3.3K	5%	1/4W
R714	1-249-425-11	CARBON	4.7K	5%	1/4W F
R742	1-249-426-11	CARBON	5.6K	5%	1/4W
R743	1-249-425-11	CARBON	4.7K	5%	1/4W F
R744	1-249-429-11	CARBON	10K	5%	1/4W
R745	1-249-435-11	CARBON	33K	5%	1/4W
< SWITCH >					
S701	1-762-875-21	SWITCH, KEYBOARD (● REC)			
S702	1-762-875-21	SWITCH, KEYBOARD (■)			
S703	1-762-875-21	SWITCH, KEYBOARD (▶▶)			
S704	1-762-875-21	SWITCH, KEYBOARD (◀◀)			
S705	1-762-875-21	SWITCH, KEYBOARD (▣)			
S706	1-762-875-21	SWITCH, KEYBOARD (▷)			
S711	1-762-875-21	SWITCH, KEYBOARD (MENU/NO)			
S712	1-762-875-21	SWITCH, KEYBOARD (YES)			

Ref. No.	Part No.	Description	Remark	Ref. No.	Part No.	Description	Remark
S713	1-475-543-11	ENCODER, ROTARY (AMS (PUSH ENTER))		C339	1-164-159-11	CERAMIC	0.1uF 50V
S714	1-762-875-21	SWITCH, KEYBOARD (CLEAR)		C341	1-162-207-31	CERAMIC	22PF 5% 50V
S741	1-771-047-11	SWITCH, SLIDE (INPUT)		C342	1-162-205-31	CERAMIC	18PF 5% 50V
S746	1-571-427-11	SWITCH, SLIDE (REC MODE)		C349	1-162-282-31	CERAMIC	100PF 10% 50V
*****							
*	A-4699-922-A	MAIN BOARD, COMPLETE (US,CND)		C351	1-126-926-11	ELECT	1000uF 20% 10V
*****							
*	A-4699-927-A	MAIN BOARD, COMPLETE (E,SP)		C391	1-126-933-11	ELECT	100uF 20% 16V
*****							
*	A-4699-932-A	MAIN BOARD, COMPLETE (AEP,UK,HK,AUS)		C392	1-126-933-11	ELECT	100uF 20% 16V
*****							
	2-389-320-01	CUSHION		C401	1-164-159-11	CERAMIC	0.1uF 50V
		< BATTERY >		C402	1-164-159-11	CERAMIC	0.1uF 50V
BT451	1-528-739-11	BATTERY, LITHIUM (SECONDARY)		C403	1-164-159-11	CERAMIC	0.1uF 50V
		< CAPACITOR >		C411	1-117-850-11	ELECT	15000uF 20% 16V
C101	1-130-467-00	MYLAR	470PF 5% 50V	C413	1-126-040-11	ELECT	1000uF 20% 35V
C111	1-126-964-11	ELECT	10uF 20% 50V	C415	1-126-040-11	ELECT	1000uF 20% 35V
C121	1-137-368-11	FILM	0.0047uF 5% 50V	C421	1-128-576-11	ELECT	100uF 20% 63V
C122	1-137-368-11	FILM	0.0047uF 5% 50V	C422	1-164-159-11	CERAMIC	0.1uF 50V
C161	1-137-360-11	FILM	220PF 5% 50V	C423	1-126-968-11	ELECT	100uF 20% 50V
C165	1-137-358-11	FILM	100PF 5% 50V	C424	1-128-551-11	ELECT	22uF 20% 25V
C166	1-137-358-11	FILM	100PF 5% 50V	C430	1-164-159-11	CERAMIC	0.1uF 50V
C171	1-126-933-11	ELECT	100uF 20% 10V	C431	1-126-966-11	ELECT	33uF 20% 16V
C172	1-137-368-11	FILM	0.0047uF 5% 50V	C433	1-124-252-00	ELECT	0.33uF 20% 50V
C173	1-137-364-11	FILM	0.001uF 5% 50V	C434	1-126-916-11	ELECT	1000uF 20% 6.3V
C181	1-128-551-11	ELECT	22uF 20% 25V	C435	1-126-964-11	ELECT	10uF 20% 50V
C183	1-130-467-00	MYLAR	470PF 5% 50V	C436	1-164-159-11	CERAMIC	0.1uF 50V
C201	1-130-467-00	MYLAR	470PF 5% 50V	C437	1-164-159-11	CERAMIC	0.1uF 50V
C211	1-126-964-11	ELECT	10uF 20% 50V	C438	1-126-923-11	ELECT	220uF 20% 10V
C221	1-137-368-11	FILM	0.0047uF 5% 50V	C439	1-126-926-11	ELECT	1000uF 20% 10V
C222	1-137-368-11	FILM	0.0047uF 5% 50V	C440	1-126-964-11	ELECT	10uF 20% 50V
C261	1-137-360-11	FILM	220PF 5% 50V	C461	1-126-923-11	ELECT	220uF 20% 10V
C265	1-137-358-11	FILM	100PF 5% 50V	C462	1-126-935-11	ELECT	470uF 20% 16V
C266	1-137-358-11	FILM	100PF 5% 50V	C464	1-126-923-11	ELECT	220uF 20% 10V
C271	1-126-933-11	ELECT	100uF 20% 10V	C465	1-126-935-11	ELECT	470uF 20% 16V
C272	1-137-368-11	FILM	0.0047uF 5% 50V	C472	1-126-933-11	ELECT	100uF 20% 16V
C273	1-137-364-11	FILM	0.001uF 5% 50V	C473	1-162-306-11	CERAMIC	0.01uF 20% 16V
C281	1-128-551-11	ELECT	22uF 20% 25V	C474	1-162-306-11	CERAMIC	0.01uF 20% 16V
C283	1-130-467-00	MYLAR	470PF 5% 50V	C500	1-131-347-00	TANTALUM	1uF 10% 35V
C301	1-162-306-11	CERAMIC	0.01uF 20% 16V	C512	1-164-159-11	CERAMIC	0.1uF 50V
C303	1-162-306-11	CERAMIC	0.01uF 20% 16V	C516	1-164-159-11	CERAMIC	0.1uF 50V
C306	1-126-933-11	ELECT	100uF 20% 10V	C519	1-162-294-31	CERAMIC	0.001uF 10% 50V
C311	1-164-159-11	CERAMIC	0.1uF 50V	C531	1-162-282-31	CERAMIC	100PF 10% 50V
C312	1-164-159-11	CERAMIC	0.1uF 50V	C533	1-162-282-31	CERAMIC	100PF 10% 50V
C313	1-164-159-11	CERAMIC	0.1uF 50V	C562	1-164-159-11	CERAMIC	0.1uF 50V
C331	1-126-923-11	ELECT	220uF 20% 10V	C571	1-162-282-31	CERAMIC	100PF 10% 50V
C333	1-126-923-11	ELECT	220uF 20% 10V	C572	1-162-282-31	CERAMIC	100PF 10% 50V
C334	1-126-923-11	ELECT	220uF 20% 10V	C573	1-162-282-31	CERAMIC	100PF 10% 50V
C335	1-164-159-11	CERAMIC	0.1uF 50V	C575	1-162-282-31	CERAMIC	100PF 10% 50V
C337	1-164-159-11	CERAMIC	0.1uF 50V	C593	1-162-294-31	CERAMIC	0.001uF 10% 50V
C338	1-126-923-11	ELECT	220uF 20% 10V	C594	1-162-294-31	CERAMIC	0.001uF 10% 50V
				C595	1-162-294-31	CERAMIC	0.001uF 10% 50V
				C597	1-162-294-31	CERAMIC	0.001uF 10% 50V
				C598	1-164-159-11	CERAMIC	0.1uF 50V
				C599	1-164-159-11	CERAMIC	0.1uF 50V
				C601	1-162-306-11	CERAMIC	0.01uF 20% 16V
				C611	1-164-159-11	CERAMIC	0.1uF 50V
				C612	1-162-306-11	CERAMIC	0.01uF 20% 16V
				C613	1-126-963-11	ELECT	4.7uF 20% 50V
				C621	1-164-159-11	CERAMIC	0.1uF 50V
							(US,CND)

# MAIN

Ref. No.	Part No.	Description	Remark
C622	1-162-306-11	CERAMIC	0.01uF 20% 16V (US,CND)
C623	1-126-963-11	ELECT	4.7uF 20% 50V (US,CND)
C631	1-164-159-11	CERAMIC	0.1uF 50V (AEP,UK,E,SP,HK,AUS)
C661	1-164-159-11	CERAMIC	0.1uF 50V
△C901	1-113-920-11	CERAMIC	0.0022uF 20% 250V
△C902	1-113-920-11	CERAMIC	0.0022uF 20% 250V
< CONNECTOR >			
CN341	1-784-418-11	CONNECTOR (FFC) 21P	
CN421	1-770-167-11	CONNECTOR, FFC/FPC 19P	
CN501	1-784-417-11	CONNECTOR (FFC) 23P	
* CN502	1-568-934-11	PIN, CONNECTOR (SMALL TYPE) 7P	
CN901	1-580-230-11	PIN, CONNECTOR (PC BOARD) 2P	
< DIODE >			
D411	8-719-200-82	DIODE 11ES2	
D412	8-719-200-82	DIODE 11ES2	
D413	8-719-200-82	DIODE 11ES2	
D414	8-719-200-82	DIODE 11ES2	
D415	8-719-200-82	DIODE 11ES2	
D416	8-719-200-82	DIODE 11ES2	
D421	8-719-200-82	DIODE 11ES2	
D423	8-719-986-16	DIODE HZS11A3LTA	
D431	8-719-911-19	DIODE 1SS119	
D432	8-719-911-19	DIODE 1SS119	
D439	8-719-911-19	DIODE 1SS119	
D451	8-719-210-21	DIODE 11EQS04	
D452	8-719-210-21	DIODE 11EQS04	
D461	8-719-210-21	DIODE 11EQS04	
D463	8-719-210-21	DIODE 11EQS04	
< GROUND PLATE >			
EP302	1-537-771-21	TERMINAL BOARD, GROUND (US,CND)	
EP304	1-537-771-21	TERMINAL BOARD, GROUND	
* EP401	4-962-200-01	PLATE (TR), GROUND	
< IC >			
IC301	8-759-426-97	IC LA9615	
IC310	8-759-633-42	IC M5293L	
IC321	8-759-426-99	IC CXD8607N	
IC391	8-759-634-50	IC M5218AL	
IC431	8-759-525-48	IC LA5632	
IC461	8-759-708-06	IC NJM78L06A	
IC463	8-759-700-69	IC NJM79L12A	
IC471	8-759-822-09	IC LB1641	
IC501	8-759-526-40	IC M30610MCA-251FP	
IC601	8-759-917-18	IC SN74HCU04AN	
IC611	8-749-012-70	IC GP1F38R	
(DIGITAL OPTICAL IN1)(US/CND)/(DIGITAL OPTICAL IN)(EXCEPT US/CND)			
IC621	8-749-012-70	IC GP1F38R (DIGITAL OPTICAL IN2)(US/CND)	
IC661	8-749-012-69	IC GP1F38T (DIGITAL OPTICAL OUT)	
< JACK >			
J101	1-784-429-11	JACK, PIN 4P (LINE (ANALOG)) (AEP,UK,E,SP,HK,AUS)	

Ref. No.	Part No.	Description	Remark
J101	1-784-430-11	JACK, PIN 4P (LINE (ANALOG))(US,CND)	
J631	1-784-431-11	JACK, PIN 1P (COAXIAL IN) (AEP,UK,E,SP,HK,AUS)	
< COIL >			
L346	1-414-793-21	INDUCTOR, FERRITE BEAD	
L347	1-414-793-21	INDUCTOR, FERRITE BEAD	
L411	1-414-747-11	INDUCTOR, FERRITE BEAD	
L412	1-414-747-11	INDUCTOR, FERRITE BEAD	
L611	1-410-509-11	INDUCTOR 10uH	
L661	1-410-509-11	INDUCTOR 10uH	
< LINE FILTER >			
△LF901	1-424-485-11	FILTER, LINE	
< TRANSISTOR >			
Q186	8-729-044-08	TRANSISTOR 2SD1915(F)-T(TA).SO	
Q286	8-729-044-08	TRANSISTOR 2SD1915(F)-T(TA).SO	
Q306	8-729-422-57	TRANSISTOR UN4111	
Q471	8-729-900-80	TRANSISTOR DTC114ES	
Q472	8-729-119-76	TRANSISTOR 2SA1175-HFE	
< RESISTOR >			
R21	1-249-437-11	CARBON 47K 5% 1/4W	
R22	1-249-437-11	CARBON 47K 5% 1/4W	
R81	1-249-441-11	CARBON 100K 5% 1/4W (US,CND)	
R82	1-249-441-11	CARBON 100K 5% 1/4W (AEP,UK,E,SP,HK,AUS)	
R101	1-249-429-11	CARBON 10K 5% 1/4W	
R102	1-247-868-11	CARBON 36K 5% 1/4W	
R111	1-249-431-11	CARBON 15K 5% 1/4W F	
R112	1-249-432-11	CARBON 18K 5% 1/4W F	
R113	1-249-437-11	CARBON 47K 5% 1/4W F	
R114	1-249-437-11	CARBON 47K 5% 1/4W F	
R115	1-249-429-11	CARBON 10K 5% 1/4W	
R116	1-249-429-11	CARBON 10K 5% 1/4W	
R121	1-249-401-11	CARBON 47 5% 1/4W F	
R122	1-249-401-11	CARBON 47 5% 1/4W F	
R161	1-249-429-11	CARBON 10K 5% 1/4W	
R162	1-249-429-11	CARBON 10K 5% 1/4W	
R163	1-249-427-11	CARBON 6.8K 5% 1/4W F	
R164	1-249-427-11	CARBON 6.8K 5% 1/4W F	
R165	1-249-433-11	CARBON 22K 5% 1/4W	
R166	1-249-433-11	CARBON 22K 5% 1/4W	
R171	1-249-429-11	CARBON 10K 5% 1/4W	
R172	1-249-421-11	CARBON 2.2K 5% 1/4W F	
R173	1-249-417-11	CARBON 1K 5% 1/4W F	
R181	1-249-415-11	CARBON 680 5% 1/4W F	
R182	1-249-441-11	CARBON 100K 5% 1/4W	
R183	1-249-411-11	CARBON 330 5% 1/4W	
R186	1-249-429-11	CARBON 10K 5% 1/4W	
R191	1-249-401-11	CARBON 47 5% 1/4W F	
R192	1-249-401-11	CARBON 47 5% 1/4W F	
R201	1-249-429-11	CARBON 10K 5% 1/4W	
R202	1-247-868-11	CARBON 36K 5% 1/4W	
R206	1-249-401-11	CARBON 47 5% 1/4W F	

The components identified by mark △ or dotted line with mark △ are critical for safety. Replace only with part number specified.

Les composants identifiés par une marque △ sont critiques pour la sécurité. Ne les remplacer que par une pièce portant le numéro spécifié.

Ref. No.	Part No.	Description	Remark	Ref. No.	Part No.	Description	Remark
R211	1-249-431-11	CARBON	15K 5% 1/4W F	R549	1-249-429-11	CARBON	10K 5% 1/4W
R212	1-249-432-11	CARBON	18K 5% 1/4W F	R550	1-249-429-11	CARBON	10K 5% 1/4W
R213	1-249-437-11	CARBON	47K 5% 1/4W F	R551	1-249-429-11	CARBON	10K 5% 1/4W
R214	1-249-437-11	CARBON	47K 5% 1/4W F	R553	1-249-429-11	CARBON	10K 5% 1/4W
R215	1-249-429-11	CARBON	10K 5% 1/4W	R559	1-249-429-11	CARBON	10K 5% 1/4W
R216	1-249-429-11	CARBON	10K 5% 1/4W	R560	1-249-429-11	CARBON	10K 5% 1/4W
R221	1-249-401-11	CARBON	47 5% 1/4W F	R561	1-249-441-11	CARBON	100K 5% 1/4W
R222	1-249-401-11	CARBON	47 5% 1/4W F	R566	1-249-441-11	CARBON	100K 5% 1/4W
R252	1-249-401-11	CARBON	47 5% 1/4W F	R568	1-249-429-11	CARBON	10K 5% 1/4W
R253	1-249-401-11	CARBON	47 5% 1/4W F	R569	1-249-429-11	CARBON	10K 5% 1/4W
R261	1-249-429-11	CARBON	10K 5% 1/4W	R573	1-249-429-11	CARBON	10K 5% 1/4W
R262	1-249-429-11	CARBON	10K 5% 1/4W	R574	1-249-429-11	CARBON	10K 5% 1/4W
R263	1-249-427-11	CARBON	6.8K 5% 1/4W F	R575	1-249-429-11	CARBON	10K 5% 1/4W
R264	1-249-427-11	CARBON	6.8K 5% 1/4W F	R577	1-249-429-11	CARBON	10K 5% 1/4W
R265	1-249-433-11	CARBON	22K 5% 1/4W	R581	1-249-441-11	CARBON	100K 5% 1/4W
R266	1-249-433-11	CARBON	22K 5% 1/4W				(AEP,UK,E,SP,HK,AUS)
R271	1-249-429-11	CARBON	10K 5% 1/4W	R582	1-249-441-11	CARBON	100K 5% 1/4W
R272	1-249-421-11	CARBON	2.2K 5% 1/4W F				(US,CND)
R273	1-249-417-11	CARBON	1K 5% 1/4W F	R589	1-249-429-11	CARBON	10K 5% 1/4W
R281	1-249-415-11	CARBON	680 5% 1/4W F	R591	1-249-429-11	CARBON	10K 5% 1/4W
R282	1-249-441-11	CARBON	100K 5% 1/4W	R593	1-249-429-11	CARBON	10K 5% 1/4W
R283	1-249-411-11	CARBON	330 5% 1/4W	R594	1-249-429-11	CARBON	10K 5% 1/4W
R286	1-249-429-11	CARBON	10K 5% 1/4W	R595	1-249-429-11	CARBON	10K 5% 1/4W
R291	1-249-401-11	CARBON	47 5% 1/4W F	R597	1-249-429-11	CARBON	10K 5% 1/4W
R292	1-249-401-11	CARBON	47 5% 1/4W F	R613	1-247-895-00	CARBON	470K 5% 1/4W
R301	1-249-429-11	CARBON	10K 5% 1/4W	R614	1-249-437-11	CARBON	47K 5% 1/4W
R302	1-249-429-11	CARBON	10K 5% 1/4W	R623	1-247-895-00	CARBON	470K 5% 1/4W
R341	1-247-903-00	CARBON	1M 5% 1/4W	R624	1-249-437-11	CARBON	47K 5% 1/4W
R342	1-249-417-11	CARBON	1K 5% 1/4W F	R631	1-247-804-11	CARBON	75 5% 1/4W
R346	1-249-829-81	CARBON	820 5% 1/4W F				(AEP,UK,E,SP,HK,AUS)
R348	1-249-413-11	CARBON	470 5% 1/4W F	R632	1-249-417-11	CARBON	1K 5% 1/4W F
R382	1-247-883-00	CARBON	150K 5% 1/4W				(AEP,UK,E,SP,HK,AUS)
R391	1-249-409-11	CARBON	220 5% 1/4W F	R634	1-247-891-00	CARBON	330K 5% 1/4W
R392	1-249-409-11	CARBON	220 5% 1/4W F	R635	1-249-438-11	CARBON	56K 5% 1/4W
R421	1-249-385-11	CARBON	2.2 5% 1/4W F	R636	1-249-417-11	CARBON	1K 5% 1/4W F
R422	1-249-433-11	CARBON	22K 5% 1/4W			< SWITCH >	
R424	1-249-441-11	CARBON	100K 5% 1/4W	△S901	1-572-675-11	SWITCH, POWER VOLTAGE CHANGE	
R431	1-247-807-31	CARBON	100 5% 1/4W			(VOLTAGE SELECTOR)(E,SP)	
R432	1-249-416-11	CARBON	820 5% 1/4W F			< VIBRATOR >	
R433	1-249-410-11	CARBON	270 5% 1/4W F	X341	1-579-314-11	VIBRATOR, CRYSTAL (22.5792MHz)	
R434	1-249-429-11	CARBON	10K 5% 1/4W	X513	1-767-845-21	VIBRATOR, CERAMIC (7MHz)	
R435	1-249-441-11	CARBON	100K 5% 1/4W			*****	
R439	1-249-433-11	CARBON	22K 5% 1/4W				
R451	1-249-409-11	CARBON	220 5% 1/4W F				
R472	1-249-435-11	CARBON	33K 5% 1/4W	*	1-668-239-11	POWER SW BOARD	
R473	1-249-429-11	CARBON	10K 5% 1/4W			*****	
R474	1-249-431-11	CARBON	15K 5% 1/4W			< CONNECTOR >	
R500	1-249-429-11	CARBON	10K 5% 1/4W	CN751	1-784-345-11	CONNECTOR(BOARD TO BOARD PLUG)	
R513	1-247-903-00	CARBON	1M 5% 1/4W			< DIODE >	
R519	1-249-429-11	CARBON	10K 5% 1/4W	D756	8-719-046-46	DIODE SEL5221S-TH8F (STANDBY)	
R521	1-249-429-11	CARBON	10K 5% 1/4W			< TRANSISTOR >	
R522	1-249-429-11	CARBON	10K 5% 1/4W				
R531	1-249-429-11	CARBON	10K 5% 1/4W	Q756	8-729-422-57	TRANSISTOR UN4111	
R532	1-249-429-11	CARBON	10K 5% 1/4W				
R533	1-249-429-11	CARBON	10K 5% 1/4W				
R546	1-249-441-11	CARBON	100K 5% 1/4W				
R548	1-249-429-11	CARBON	10K 5% 1/4W				

The components identified by mark △ or dotted line with mark △ are critical for safety. Replace only with part number specified.	Les composants identifiés par une marque △ sont critiques pour la sécurité. Ne les remplacer que par une pièce portant le numéro spécifié.
--	--

**POWER SW**      **SW**

Ref. No.	Part No.	Description	Remark
		< RESISTOR >	
R752	1-249-429-11	CARBON      10K      5%      1/4W	
R756	1-249-409-11	CARBON      220      5%      1/4W F	
		< SWITCH >	
S726	1-762-875-21	SWITCH, KEYBOARD (I/⏻)	
S751	1-572-210-11	SWITCH, SLIDE (TIMER)	
*****			
*	1-668-111-11	SW BOARD *****	
		< CONNECTOR >	
CN601	1-506-486-11	PIN, CONNECTOR 7P	
		< SWITCH >	
S601	1-572-126-11	SWITCH, PUSH (1 KEY)(REC POSITION)	
S602	1-572-126-11	SWITCH, PUSH (1 KEY)(PACK OUT)	
S603	1-771-264-11	SWITCH, PUSH (CHUCKING IN)	
S604	1-771-264-11	SWITCH, PUSH (PB POSITION)	
*****			
		MISCELLANEOUS *****	
△ 4	1-558-945-21	CORD, POWER (POLAR.SPT-1)(US,CND)	
△ 4	1-696-586-21	CORD, POWER (UK,HK)	
△ 4	1-696-846-21	CORD, POWER (AUS)	
△ 4	1-751-275-11	CORD, POWER (AEP,E,SP)	
△ 5	1-569-008-11	ADAPTOR, CONVERSION 2P (E,SP)	
8	1-783-138-11	WIRE (FLAT TYPE)(19 CORE)	
11	1-783-140-11	WIRE (FLAT TYPE)(23 CORE)	
12	1-783-139-11	WIRE (FLAT TYPE)(21 CORE)	
258	1-667-954-11	FLEXIBLE BOARD	
△ 260	8-583-028-02	OPTICAL PICK-UP KMS-260A/J1N	
FL781	1-517-738-11	INDICATOR TUBE, FLUORESCENT	
HR901	1-500-502-11	HEAD, OVER WRITE	
M101	A-4672-475-A	MOTOR ASSY, SPINDLE	
M102	A-4672-474-A	MOTOR ASSY, SLED	
M103	X-4949-264-1	MOTOR ASSY, LOADING	
S102	1-762-148-21	SWITCH, PUSH (REFLECT/PROTECT)	
△ TR901	1-431-684-11	TRANSFORMER, POWER (E,SP)	
△ TR901	1-431-685-11	TRANSFORMER, POWER (AEP,UK,HK,AUS)	
△ TR901	1-431-686-11	TRANSFORMER, POWER (US,CND)	
*****			

Ref. No.	Part No.	Description	Remark
		ACCESSORIES & PACKING MATERIALS *****	
	1-475-586-11	REMOTE COMMANDER (RM-D15M)	
	1-558-271-11	CORD, CONNECTION (AUDIO 108cm) (EXCEPT US,CND)	
	1-574-264-11	CORD, OPTICAL PLUG (CND,AEP,UK,E,SP,HK,AUS)	
	1-776-263-51	CORD, CONNECTION (AUDIO 100cm)(US,CND)	
	3-862-735-11	MANUAL, INSTRUCTION (ENGLISH,FRENCH)(US,CND)	
	3-862-735-21	MANUAL, INSTRUCTION (CHINESE)(E,SP,HK)	
	3-862-735-31	MANUAL, INSTRUCTION (ENGLISH,FRENCH,SPANISH,PORTUGUESE) (AEP,UK,E,SP,HK,AUS)	
	3-862-735-41	MANUAL, INSTRUCTION (GERMAN,DUTCH,ITALIAN)(AEP)	
	3-862-735-51	MANUAL, INSTRUCTION (SWEDISH,DANISH,FINNISH)(AEP)	
	3-862-735-61	MANUAL, INSTRUCTION (ENGLISH,POLISH,ROSSIAN)(AEP)	
	3-862-735-71	MANUAL, INSTRUCTION (GREEK)(AEP)	
	3-862-735-81	MANUAL, INSTRUCTION (CZECH)(AEP)	
	4-983-537-01	COVER, BATTERY (FOR RM-D15M)	
*****			
		HARDWARE LIST *****	
#1	7-685-646-01	SCREW +BVPT 3X8 TYPE1	
#2	7-685-131-19	SCREW (DIA. 2.6) (IT3B)	
#3	7-621-772-20	SCREW +B 2X5	
#4	7-621-772-40	SCREW +B 2X8	
#5	7-627-852-08	SCREW,PRECISION +P1.7X2.5TYPE3	
#6	7-685-533-19	SCREW +BTP 2.6X6 TYPE2 N-S	

The components identified by mark △ or dotted line with mark △ are critical for safety. Replace only with part number specified.	Les composants identifiés par une marque △ sont critiques pour la sécurité. Ne les remplacer que par une pièce portant le numéro spécifié.
--	--