

# Colour TV pattern generator

## PM 5519

9452 055 19003

Service manual

9499 525 00711

870501/4



**I&E**

Industrial & Electro-acoustic Systems Division



**Industrial &  
Electro-acoustic Systems**

**PHILIPS**



# SERVICE

Scientific & Analytical Equipment  
 Test & Measuring Instruments  
 Industrial Controls  
 Welding  
 Industrial Data-processing Systems

**Scientific &  
 Industrial  
 Equipment  
 Division**

840501

TEST AND MEASURING INSTRUMENTS

SGS 37

9499 528 03811

PM 5519 Colour pattern generator

Already published: SGS 20, SGS 27, SGS 30

Latest instruction manual: 9499 525 00711 820801/3/01-10

1. Problem: BAR-signal incorrect (e.g. one colour missing)  
 Solution: Insert capacitor 596, 150 pF, 4822 122 31413, on soldering side of unit 10, between pin 8 and 7 of IC 359.

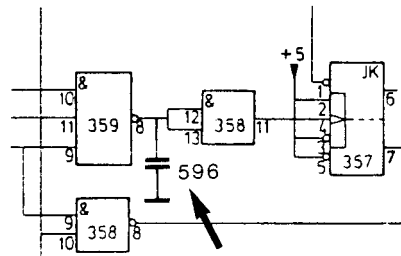

2. Diode BB 113, pos. 402 within the VHF/UHF modulator is replaced by 2 single diodes BB 130, 5322 130 32281. Because of the exchange a capacitor 39 pF parallel to C511 has to be added.

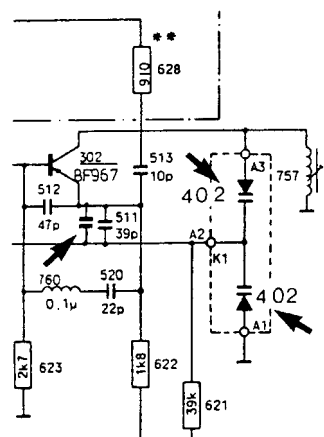
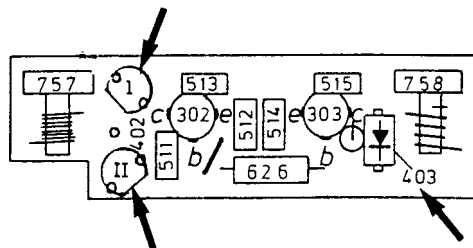

3. Diodes BB 105B, pos. 401/403 within the VHF/UHF modulator are replaced by diodes BB 405B, service code 5322 130 34953.

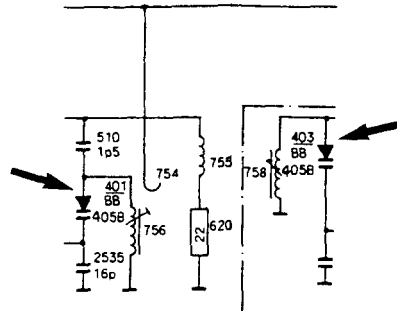

4. Within series L0 016.....IC351, TCA820 in the modulator is replaced by TDA820 T, 5322 209 81981.

Additional alterations:

C 501, 502, 506	altered to 1nF	5322 122 31998
R 602	" " 3K01	5322 116 54582

The pinning of TCA820 and TDA0820T is different.

TCA820 is not available anymore at Concern Service. In case of defective TCA820 a new complete VHF/UHF modulator 5322 218 64054 must be taken.

5. Please correct Service manual, chapter 2.1.2:  $V = 312,5$  (or  $262,5$ ) lines.
6. OQ 5501, pos. 351/unit 10, is not available due to end of production. Replacement type is OQ 5506 (same pinning), service code 5322 209 81945.

Additional alterations:

Remove NTC-resistor 330E pos. 605, replace resistor 42.2E, pos. 608 by 53.6E/MR 25, 5322 116 54444.

# Colour TV pattern generator

## PM 5519

9452 055 19003

### Service manual

9499 525 00711

870501/4

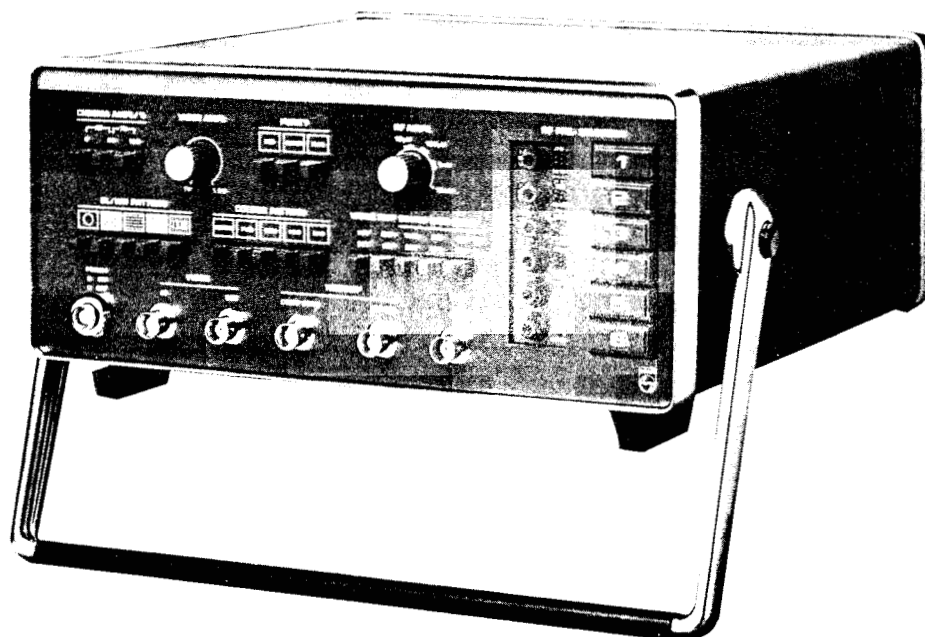

# PHILIPS

#### Please note

In correspondence concerning this instrument, please quote the type number and serial number as given on the type plate.

#### Bitte beachten

Bei Schriftwechsel über dieses Gerät wird gebeten, die Typennummer und die Geratenummer anzugeben. Diese befinden sich auf dem Typenschild an der Rückseite des Gerätes.

#### Note s.v.p.

Dans votre correspondance et dans vos réclamations se rapportant à cet appareil, veuillez toujours indiquer le numéro de type et le numéro de série qui sont marqués sur la plaquette de caractéristiques.

#### Important

As the instrument is an electrical apparatus, it may be operated only by trained personnel. Maintenance and repairs may also be carried out only by qualified personnel.

#### Wichtig

Da das Gerät ein elektrisches Betriebsmittel ist, darf die Bedienung nur durch eingewiesenes Personal erfolgen. Wartung und Reparatur dürfen nur von geschultem, fach- und sachkundigem Personal durchgeführt werden.

#### Important

Comme l'instrument est un équipement électrique, le service doit être assuré par du personnel qualifié. De même, l'entretien et les réparations sont confiés aux personnes suffisamment qualifiées.



# SERVICE

**Scientific &  
Industrial  
Equipment  
Division**

**850401** TEST AND MEASURING INSTRUMENTS

SGS47

9499 528 04411

**PM 5519** Colour TV pattern generator

Already published: SGS20, SGS27, SGS30, SGS37

Latest service manual: 9499 525 0071 1, dated 820801/3/01-10

1. Problem: In VIDEO EXT operating mode
- the pack porche of the sync pulse is distorted and
  - the working point of transistor 317 is not okay.
- Solution:
- Transistor 317, BC 338, video input amplifler, unit 10 is replaced by BC 337-16, 5322 130 41095 from instruments L 0 18 ... onwards.
  - Resistor 730 is paralalled by a resistor 56K2.
2. Problem: IC 351 on unit 3, TCA 240, was sometimes not working properly.
- Solution: Alteration of resistor 604 from 825R to 715R, already inserted from L 0 13 ... onwards.
3. Problem: Diode BA 244, items 402, 404, 406 on unit 2 is not available anymore.
- Solution: Replaced by diode BA 482, 5322 130 34955, already inserted from L 0 17 ... onwards
4. Problem: The small knobs 5322 414 30027 for memostat, pie-selection unit, can sometimes be damaged.
- Solution: Please operate the knobs only by hands or by cross-slotted screw-driver.  
Don't operate with normal screw driver.

5. Problem:
- Sound interference into Video
  - Residual carrier amplitude

- Solution:
- VHF/UHF modulator 5322 218 64054 is equipped with additional metal screening sheet, from Dec. 84 onwards.
  - Resistor 716, unit 10 is altered to 13K3;  
Resistor 716 is paralleled by capacitor 598, OP68, 4822 122 31213;  
resistor 722 is altered to 8K25, see figure.
  - Diode 434 in the 1 kHz oscillator, unit 10 is paralleled by capacitor 597, 1 N, 4822 122 31175 see figure.

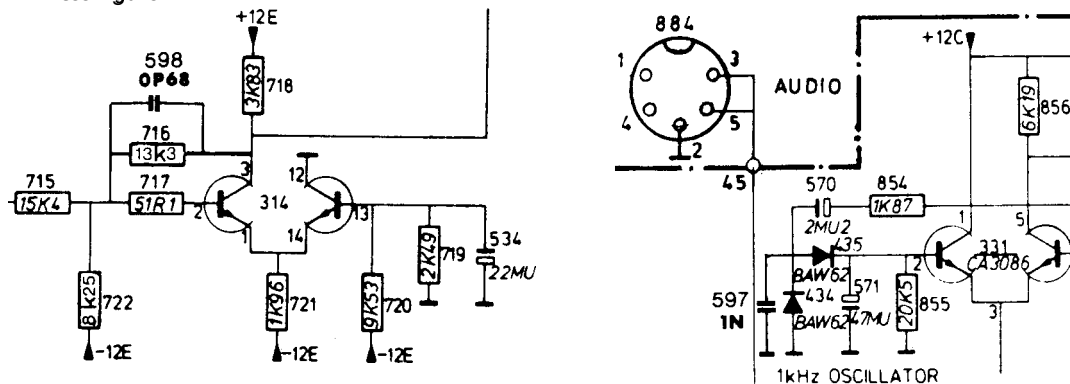

- Some chapters 'CHECK AND ADJUSTMENT' of the service manual are revised:

4.4.1. Sub-carrier amplitude

- Connect oscilloscope with 10 : 1 probe to TP 5, pin 11/U 1.
- Check the sub-carrier amplitude: 2.5 Vpp f0.5 V.
- If necessary readjust with 604

4.6.2. Residual RF carrier series L 0 17 ... onwards (new VHF/UHF modulator type)

- select abt. 200 MHz in the VHF range
- set attenuator RF AMPL to max. output level (10 mV).
- select WHITE test pattern
- connect spectrum analyzer\* to RF OUT
- adjust residual carrier with potmeter 606 of the VHF/UHF-modulator to 10% ... 12% (20dB ... 18 dB), from the sync. tips to white bar.
- set PM 5519 to abt. 623 MHz in the UHF-range channel 40.
- select GREYSCALE test pattern and set the attenuator RF AMPL to abt. 1 mV.
- connect CTV receiver to RF OUT
- check that greyscale pattern is correct (modulation not overdriven). Otherwise readjust residual carrier with potmeter 606.
- check that the residual carrier is within < 30 % in the whole VHF/UHF range.

\* if no spectrum analyzer available use well adjusted CTV receiver and connect oscilloscope (50 MHz) via high impedance probe to the IF-stage.

4.1.1.3. Amplitude RF/soundcarrier

- Pushbutton CHECKERBOARD and SOUND MOD CARR ON/OFF.
- Turn RF AMPL to maximum.
- Connect a selective voltmeter (e.g. Bruell & Kjaer 2007) to RF OUT and check that the amplitude ratio of the video to the sound carrier is 13 - 14 dB at a frequency of e.g. 200 MHz. If necessary adjust with 614/U 2.

Alteration concerns also table on page 48.

## CONTENTS

SGS 37	Service information	
SGS 47	Service information	
<b>1.</b>	<b>GENERAL</b>	<b>11</b>
1.1.	Introduction	11
1.2.	Technical data	11
1.3.	Accessories	15
1.4.	Survey of pattern	16
1.5.	Operating principle, block diagram, fig. 1	18
<b>2.</b>	<b>CIRCUIT DESCRIPTION</b> with figures 2 – 20	<b>19</b>
2.1.	General	19
2.2.	Video generator	21
2.2.1.	Raster signals	21
2.2.2.	Horizontal pattern components: vertical lines and bars	22
2.2.3.	Vertical pattern components: horizontal lines, bars and fields	24
2.2.4.	Staircase signals	26
2.2.5.	Circle components	28
2.2.6.	Synthesis of the Black/White test pattern	30
2.2.7.	Colour part	34
2.2.8.	Synthesis of the chroma signals	37
2.2.9.	Chroma and video channels	41
2.3.	Sound generator	42
2.3.1.	1 kHz oscillator	42
2.3.2.	Sound input amplifier	42
2.3.3.	Sound carrier oscillator and -modulator	42
2.4.	RF part	43
2.4.1.	VHF/UHF modulator	43
2.4.2.	RF pre-selector	43
2.5.	Power supply	43
<b>3.</b>	<b>INSTALLATION, ACCESS TO PARTS</b>	<b>45</b>
3.1.	Safety regulations	45
3.2.	Operating position	45
3.3.	Earthing	45
3.4.	Adjusting to mains voltage	46
3.5.	Dismantling the instrument	46
3.6.	Knobs	46
3.7.	Textplate	46
3.8.	Pushbutton unit	46
<b>4.</b>	<b>CHECK AND ADJUSTMENT</b>	<b>47</b>
4.1.	Survey of adjusting elements and auxiliary equipment	47
4.2.	General	49
4.3.	Power supply	49
4.4.	Modulation- and synchronisation-frequency and pulses	50
4.5.	Video signals	52
4.6.	RF-check	52
4.7.	B L/WH pattern and signals	53
4.8.	Colour signals	55
4.9.	Colour pattern signals	56
4.10.	External video	58
4.11.	Sound check, with table and figure for adjustment	58
<b>5.</b>	<b>MODIFICATION INTO VARIOUS VERSIONS</b>	<b>59</b>
5.1.	Performance details of various versions	59
5.2.	Modification of PM 5519 G into PM 5519 I	59
5.3.	Modification of PM 5519 G into PM 5519 N	59
5.4.	Modification of PM 5519 G into PM 5519 M	59
5.5.	Modification of PM 5519 G into PM 5519 MM	60
<b>6.</b>	<b>PARTS LIST</b>	<b>61</b>
6.1.	Mechanical parts, miscellaneous; with figures 21 - 23	61
6.2.	Electrical parts	64
<b>7.</b>	<b>FIGURES 24 – 35</b>	<b>76 – 79</b>
<b>8.</b>	<b>CODING SYSTEM OF FAILURE REPORTING FOR QUALITY</b>	
<b>9.</b>	<b>ADDRESSES FOR SALES AND SERVICE</b>	



## LIST OF FIGURES

Fig. 1	Block diagram	18
Fig. 2	Overall circuit diagram	20
Fig. 3	Phase locked loop of master and sub-carrier oscillator	21
Fig. 4	Field and line raster signals	22
Fig. 5.1	Pulse diagram of OQ5501: NTSC norm	23
Fig. 5.2	Pulse diagram of OQ5501: CCIR norm	23
Fig. 6	Blanking and control signals	24
Fig. 7	Horizontal pattern components	25
Fig. 8	Field pulse generation components	25
Fig. 9	Control signals for multiburst oscillator	27
Fig. 10.1	Forming the circle control pulse	29
Fig. 10.2	Forming the circle	29
Fig. 11	Digital addition of the BL/WH pattern	31
Fig. 12	Summing and scale factor of patterns and signals	32
Fig. 13	Greyscale generation	33
Fig. 14	Generation of the colour sync signal	34
Fig. 15	Phase diagram of the primary and complementary colours and of the colour sync signals	35
Fig. 16	Colour bar matrix, control signal and modulator input	35
Fig. 17	Synthesis of the Y, (R-Y) and (B-Y) signals out of the RGB components	36
Fig. 18	Colour difference modulators and phase switches of the colour carrier frequencies	37
Fig. 19	Matrix of the monochrome pattern red, green and blue	38
Fig. 20.1	Control of the colour modulator for DEM and VCR	39
Fig. 20.2	Control of the PAL and DEM phase switches	40
Fig. 21	Front view: spare parts	62
Fig. 22	Inside view: spare parts	63
Fig. 23	Back view: spare parts	63
Fig. 24	Unit 1, master oscillator, circuit diagram	76
Fig. 25	Unit 1, component lay-out	76
Fig. 26	Unit 2, sound oscillator and -modulator, circuit diagram	76
Fig. 27	Unit 2, component lay-out	76
Fig. 28	Unit 3, multiburst oscillator, circuit diagram	76
Fig. 29	Unit 3, component lay-out	76
Fig. 30	Unit 11, power supply, circuit diagram	77
Fig. 31	Unit 11, component lay-out	77
Fig. 32	VHF/UHF modulator, circuit diagram	77
Fig. 33	VHF/UHF modulator, components	77
Fig. 34	Unit 10, component lay-out	78
Fig. 35	Unit 10, circuit diagram	79

# GENERAL INFORMATION

## 1.1. INTRODUCTION

The multi-system CTV Pattern Generator PM5519 is used for servicing colour and B/W TV-sets, monitors, VCR and VLP sets. All test signals allow to determine faults by means of the screen of a TV set or monitor.

The generator provides 12 different test patterns, 7 of them in colour. In addition, the circle test pattern can be combined with any other test pattern and appears as white or black circle depending on the brightness of the selected picture.

The composite colour signal with standard number of lines (interlacing) and standard coupling of line and subcarrier frequency is available at the video output. This video signal of 1 Vpp into a 75Ω load (fixed position) is continuously adjustable from 0 to 1.5 Vpp. The amplitude of the chroma signal (including burst) is adjustable in steps of 25% from 0% to 100% of standard value.

The generator can be adapted to other TV systems.

The amplitude of the RF output signal of the generator is continuously variable. This RF signal is modulated with the video signal and the disconnectible 1 kHz-modulated sound carrier.

The carrier frequency of the generator can be tuned to all TV ranges (bands) and to the intermediate frequency. 6 tip-touch buttons are pre-settable to any frequency within the TV ranges. The preset values are displayed by the individual frequency and range indicator for each selector. The RF carrier can be modulated by video and sound signals from external signal sources via the video input and the audio socket.

For time base synchronisation of an oscilloscope, two signals are available for line or frame triggering, (comp. sync. and frame).

## 1.2. TECHNICAL DATA

Only data with indicated tolerances or limits are guaranteed; data without tolerances are given only for guidance.

### 1.2.1. Test signals

- |  |   |
|--|---|
| - CIRCLE                                   | white circle on grey background, combinable with all test patterns  |
| - CHECKERBOARD                             | 6x8 squares   |
| - DOIS                                     | 11x15 (intersections of crosshatch pattern)   |
| - CROSSHATCH                               | 11 horizontal and 15 vertical lines   |
| - GREYSCALE combined with DEFINITION LINES | staircase signal with 8 identical steps and sinusoidal line-frequent multi-burst of 0.8, 1.8, 2.8, 3.8, 4.8 Mhz |

- WHITE 100% white signal (with burst)
- PURITY red, green and blue signal selected via separate buttons, 75% saturation; also complementary by combination.
- DEM special test pattern of 4 vertical bars  
  - 1<sup>st</sup> bar (G-Y) = 0;
  - 2<sup>nd</sup> bar grey (Y)
  - 3<sup>th</sup> bar (R-Y) NTSC encoded with PAL burst;
  - 4<sup>th</sup> bar (B-Y).

The 2<sup>nd</sup> bar and lower part of the screen are for reference.
- VCR pattern with 5 horizontal bars  
  - 1) 1/6 of screen 100% Y
  - 2) 1/6 of screen 2.8 MHz
  - 3) 1/6 of screen 3.0 MHz
  - 4) 1/6 of screen 3.2 MHz
  - 5) 2/6 of screen 8-step of Linearly increasing saturation with 50% Y
- COLOUR BAR standard chroma signal with 75% saturation; the lower part of the screen is used as reference (75% Y)

Bar	Relative luminance amplitude	Chroma phase --	Relative chroma amplitude
White	0.75	-	-
Yellow	0.67	167°	±0.33
Cyan	0.53	283°	±0.47
Green	0.44	241°	±0.44
Magenta	0.31	61°	±0.44
Red	0.23	103°	±0.47
Blue	0.08	347°	±0.33
Black	0	-	-

### 1.2.2. performance details of various versions

PM 5519-	G	I	N	M	MM
TV standard	CCIR/PAL	CCIR/PAL	CCIR/PAL	RTMA/PAL	RTMA/NTSC
Lines per picture frame	625	625	625	525	525
Field frequency (Hz)	50	50	50	60	60
Line frequency (Hz)	15625	15625	15625	15734	15734
Chrominance sub-carrier (MHz)	4.433618	4.433618	3.582056	3.575611	3.579545
Sound carrier/ Vision carrier (MHz)	5,5	6	4,5	4,5	4,5
Sound modulation	FM	FM	FM	FM	FM
Pre-emphasis (µs)	50	50	75	75	75

### 1.2.3. Video Part

-Video carrier	
Frequency ranges	38 - 90 Mhz (IF and band I ) 170 - 250 MHz (band III ) 470 - 820 MHz (bands IV and V)
Range and frequency selection	6 tip-touch button to select the preset channel frequency
Indicator	of range and channel for each tip-touch button
- RF output	BNC connector (front panel)
Impedance	75 $\Omega$
Output voltage	> 10 mVpp (synchronizing level)
Attenuator	continuously >60dB
- Video modulation	AM negative (or positive, selectable by solder link); modulation will take place on IF. This modulated signal is then mixed up on RF. Internal or external modulation selectable by means of push-button
- Video outputs	
Connector 1	for VCR (rear panel)
- Coupling	DC, mean value 1.8 v
Connector 2	BNC socket (front panel)
- Coupling	AC
Impedance	75 $\Omega$
Nominal voltage	1 Vpp into a load of 75R (fixed position of VIDEO AMPL control) 0 - 1.5 Vpp, continuously adjustable, into a load of 75 $\Omega$
Polarity	positive
- Video input	BNC connector (front panel)
Impedance	75 $\Omega$
Nominal voltage	1 Vpp
Polarity	positive
Max. permissible external voltage	$\pm 5$ V

#### 1.2.4. Sound part

- Sound carrier
  - Frequency 4.5; 5.5; 6.0; 6.5 MHz, selectable by solder links;  
on delivery, adjusted to standard value
  - Tolerance <0.2%
- Sound modulation FM (or AM,selectable by solder link)
  - Internal signal 1KHz sine wave
  - FM sweep (40+-5) kHz with 5.5 MHz; slightly different with other carrier frequencies
  - AM modulation depth (30+-5) %
  - External signal 0.2 V<sub>rms</sub> results in the same modulation depth as for Internal signal
  - Bandwidth 100 Hz - 10 KHz
  - Preemphasis 50 μs (can be interrupted)
- Sound input DIN connector (rear panel)
  - Input impedance 0.5 MΩ
  - Max. permissible voltage ±40 V<sub>DC</sub>
- Sound selector carrier ON/OFF  
modulation ON/OFF  
modulation 1 kHz/external

#### 1.2.5. Sync. part

- Line frequency 15625 Hz or 15734 Hz, adjusted to standard value
- Tolerance 0.05%
- Line sync. signal according to standards CCIR and RIMA
- Lines /field 312,5 lines for f line = 15625Hz or  
262,5 lines for f line = 15734 Hz
- Field frequency 50Hz for f line =15625Hz or  
60 Hz for f<sub>line</sub> 15734 Hz
- Field sync. signal according to standards (with preequalizing and postequalizing pulses)
- RRP (Receiver Recognition Pulse) VCR identification In the synchronous pulse, selectable with button on front panel
- Sync. outputs 2 BNC connectors (front panel)
  - Output signal 1) COMP - SYNC  
2) FRAME
  - Output voltage 2 4 V
  - Impedance 15 kΩ
  - Polarity negative
  - Coupling DC (digital level)
  - Max. permissible ext. voltage +5 V and -1 V

1.2.6. Chroma part

Systems	PAL according to TV systems I, G or M; NTSC. (delivered according to standards)
Subcarrier frequency	4.433 619 MHz for PAL G and I 3.582 056 MHz for PAL N 3.575 611 MHz for PAL M 3 579 545 MHz for NTSC
- Tolerance	$\pm 5 \cdot 10^{-6}$ (+5...+40°C)
Burst	according to standards; contained in all test patterns
- Burst phase	135° and 225° for PAL, 180° for NTSC
Amplitude	burst and chroma amplitude adjustable in steps
- Attenuation	0%, 25%, 50%, 75% 100% selected by separate or combined push-buttons
Tolerance of chroma angle	$\pm 3^\circ$

## 1.2.7. Power supply

Mains voltage	110 V, 127 V, 220 V, 240 V externally switched-over
- Tolerance	$\pm 10\%$
Mains frequency	50 Hz - 60 Hz
- Tolerance	$\pm 5\%$
Power consumption	18 Watt

For Service Manuals Contact  
MAURITRON TECHNICAL SERVICES  
8 Cherry Tree Rd, Chinnor  
Oxon OX9 4QY  
Tel:- 01844-351694 Fax:- 01844-352554  
Email: enquiries@mauritron.w.uk

1.2.8. Environmental conditions

Reference temperature	+23°C
Nominal operating temperature	+5 to +40°C
Limits For storage and transportation	-40 to +70°C

This generator conforms to VDE 0411, class I, protective earth connection.

1.2.9. Dimensions (over all)

Height	140 mm
Width	305 mm
Depth	300 mm
Weight	approx. 4.5 kg

## 1.3. ACCESSORIES

Supplied with the instrument:

IM 9538 Connection Cable BNC - TV connector, 75 Ohm

Operating manual

Optional:

IM 9539 Connection Cable BNC - impedance transformer, 75 - 300 Ohm

IM 9075 Connection Cable BNC - BNC 75 Ohm

Service manual

## 1.4. SURVEY OF PATTERN

Signal content	B/W	Colour	VCR	For checking
CIRCLE	•	■		Overall linearity
White circle on grey background	•	■		Overall geometry
Black circle on white background (circle and white)	•	■		Reflections
<hr/>				
CHECKERBOARD				
6x8 B/W squares	•	■		Focus adjustment
	•	■		HOR/Vert. sync
	•	■		HOR/Vert. linearity
	•	■		HOR/Vert. deflection
	•	■		Amplitude/aspect ratio, geometry ringing,
	•	■		Bandwidth by observation of vert. transitions
	•	■	○	Mains hum interference in synchronization Black/white transitions
<hr/>				
DOTS				
11 horizontal lines of 15 dots		■		Static convergency
<hr/>				
CROSSHATCH				
11 horizontal and 15 vertical lines		■		Dynamic convergency
	•	■		Pincushion correction E/W - N/S corrections in 110 <sup>o</sup> CTV receivers
<hr/>				
GREYSCALE and DEFINITION LINES	•	■		Brightness and contrast circuit
Staircase signal white, with 8 identical steps combined with Definition lines 0.8 - 4.8 MHz (stepwidth 1MHz)	•	■		Greyscale
	•	■	○	Linearity of video amplifier
	•	■	○	Video bandwidth

Signal content	B/W	Colour	VCR	For checking
WHITE pattern	•	■		White-D
100% white signal (with burst or without burst)		■		Brightness control Beam current of picture tube Luminance writing current
PURITY pattern		■		Purity
Red, green and blue individually selectable	•	■		Interference between sound and chroma carrier Colour AGC Chrominance writing currents of video head
DEM pattern		■		PAL delay-line; amplitude and phase error detection
4 vertical bars, special encoding		■		PAL demodulators; sub-carrier frequency (phase) to (R-Y)-(B-Y) demodulators PAL switch
VCR pattern				
Chroma saturation step		■	o	Linearity of chroma amplifier
Staircase signal with 8 identical steps of saturation (R - Y) combined with Definition lines		■	o	Sensitivity of colour amplifier
2.8 MHz, 3.0 MHz, 3.2 MHz combined with horizontal white bar 100 % Y		■	o	Bandwidth setting
COLOUR BAR with white pattern		■		White level setting
75% saturation colour bar with white reference field in lower part of screen		■		Overall colour performance Burst keying Subcarrier regenerator PAL identification circuit Matrix circuit RGB amplifiers
			o	Delay colour versus B/W signal
			o	Saturation
			o	562.5 kHz interference

For Service Manuals Contact  
**MAURITRON TECHNICAL SERVICES**  
 8 Cherry Tree Rd, Chinnor  
 Oxon OX9 4QY  
 Tel:- 01844-351694 Fax:- 01844-352554  
 Email:- enquiries@mauritron.co.uk



1.5 OPERATING PRINCIPLE, BLOCK DIAGRAM

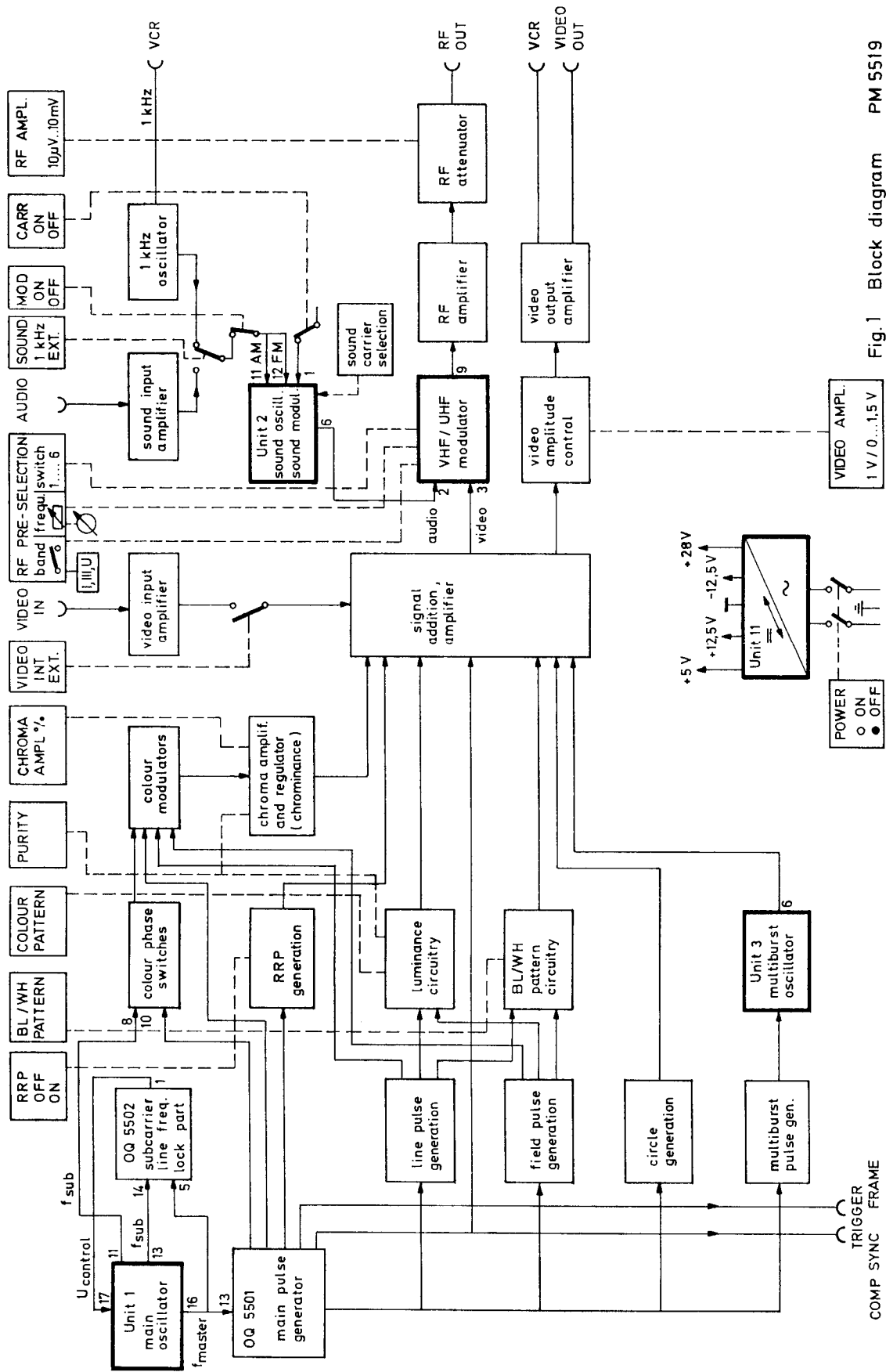

Fig.1 Block diagram PM 5519

## 2. CIRCUIT DESCRIPTION

### 2.1. GENERAL

The generation of the pattern-, sound- and raster signals is based on the synthesis of digital signals. The digital signals in the pictures are shown idealised.

2.1.1. The numeric values used in the description apply to the G- and I-version, see table 1.1.2. Modification into the versions N, M and MM see chapter 5.

2.1.2. **Explanation of symbols in the circuit diagram and the descriptions.**

$f_V$  is field frequency  $\hat{=} 50$  (or 60) Hz

$t_V$  is field time  $\hat{=} 20$  (or 16.67) ms  $\hat{=} V = 312,5$  (or 262,5) lines

$f_H$  is line frequency  $\hat{=} 15625$  (or 15734) Hz

$t_H$  is line time  $\hat{=} 64$  (or 63.56)  $\mu$ s  $\hat{=} H$ , see fig. 4

div. is the smallest time component for the synthesis of the raster and pattern signals.

2.1.3. **Component numbering:**

Numbers until 100 indicate mechanical parts, miscellaneous and units

Numbers starting with a 3 indicate transistors and IC's

Numbers starting with a 4 indicate diodes

Numbers starting with a 5 indicate capacitors

Numbers starting with a 6 indicate resistors

Numbers starting with a 7 indicate coils (and in some cases resistors)

Numbers starting with a 8 indicate switches (and in some cases resistors).

2.1.4. **Overall circuit diagram, fig. 2.**

The connections and terminations of the main unit U10, the power supply unit 11, and the controls and sockets of the sub-units of unit 10 are shown in the figure 2. The complete single circuit diagrams are shown in the figures 24, 26, 28, 30, 32 and 34.

For Service Manuals Contact  
**MAURITRON TECHNICAL SERVICES**  
 8 Cherry Tree Rd, Chinnor  
 Oxon OX9 4QY  
 Tel:- 01844-351694 Fax:- 01844-352554  
 Email:- enquiries@mauritron.co.uk

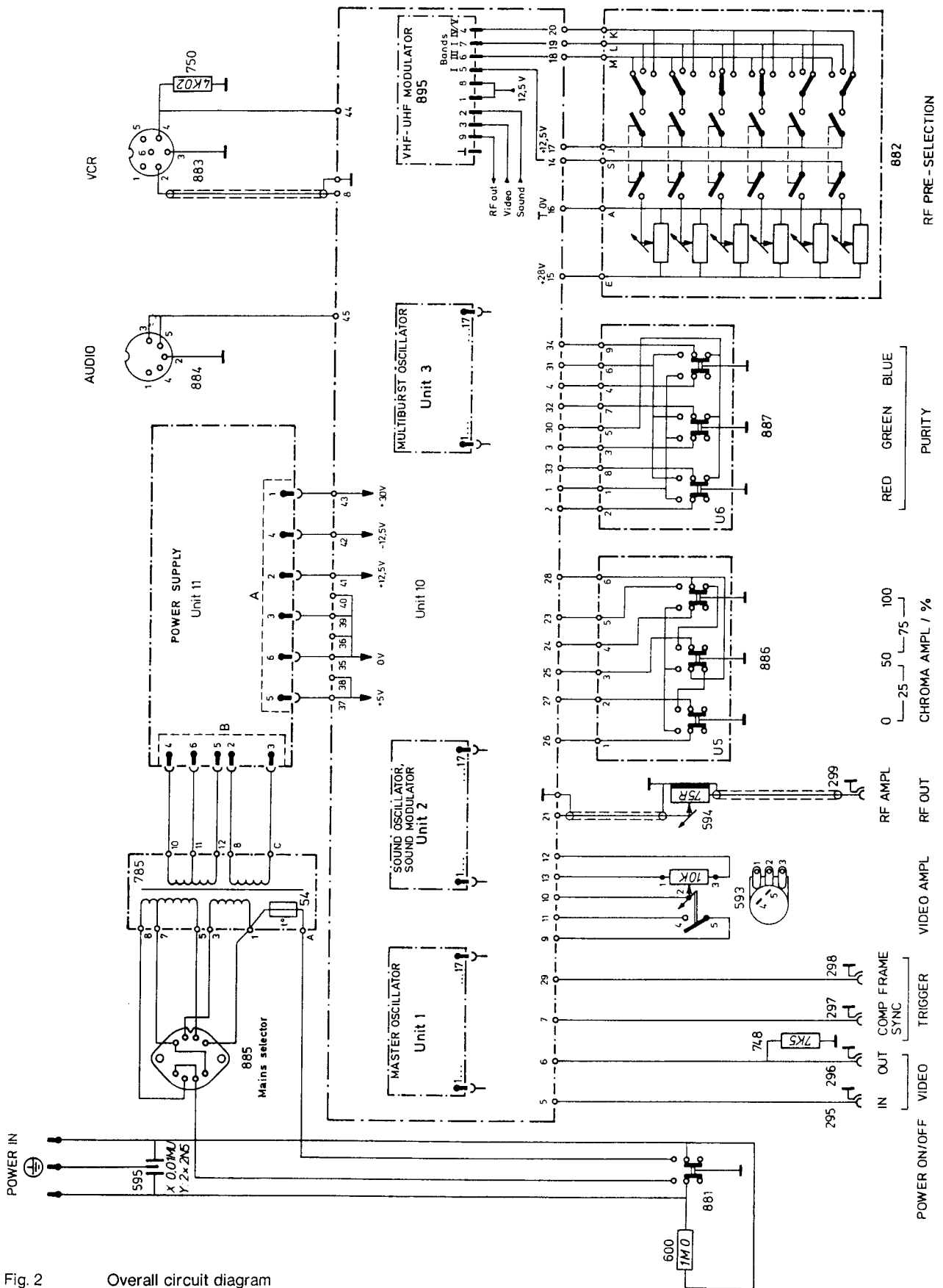

Fig. 2 Overall circuit diagram

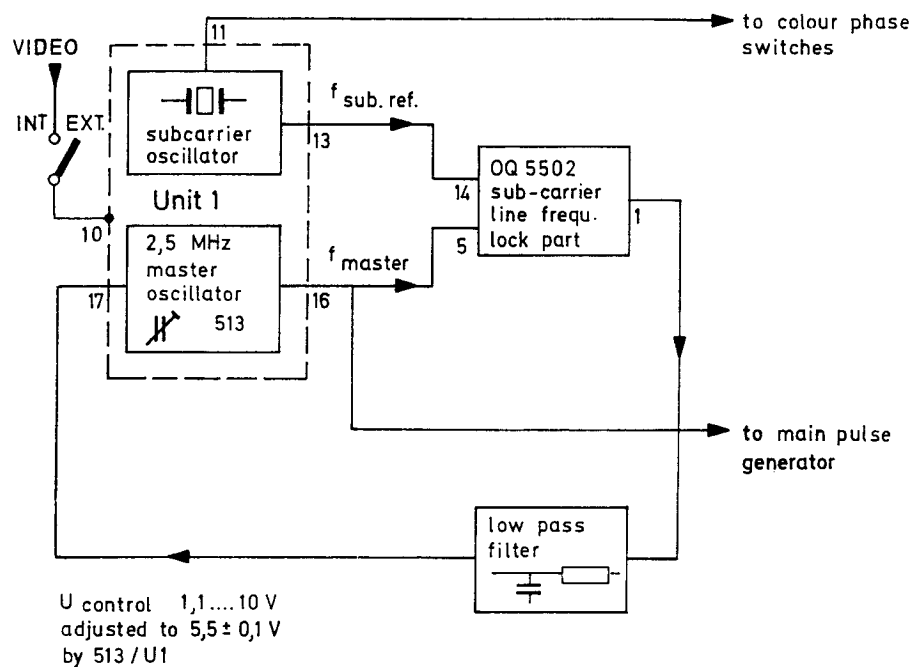

Fig. 3 Phase locked loop of master and sub-carrier oscillator

For Service Manuals Contact  
**MAURITRON TECHNICAL SERVICES**  
 8 Cherry Tree Rd, Chinnor  
 Oxon OX9 4QY  
 Tel:- 01844-351694 Fax:- 01844-352554  
 Email:- enquiries@mauritron.co.uk

## 2.2. VIDEO GENERATOR

The video generator internally generates the complete CVBS signal for 13 different BL/WH- and COLOUR PATTERN. These chapters are related only to the CCIR norm, version G. For the other versions see chapter 5.

### 2.2.1. Raster signals, fig. 4.

The high stability of the raster frequency is achieved by the phase-locked-loop (PLL) coupling of the master frequency with the sub-carrier frequency, fig. 3.

#### 2.2.1.1. Clock frequency, fig. 3.

The PLL circuitry compares the master frequency of 2.5 MHz with the sub-carrier reference frequency in the OQ5502, IC352 on unit 10 and controls the frequency deviations of the master frequency, which is set by 513/U1. So this frequency is x-tal controlled as it is fixed coupled to the sub-carrier frequency.

#### 2.2.1.2. Main pulse generator

The main pulse generator OQ5501, IC351/1 on unit 10 generates the required raster signals by dividing the master frequency of 2.5 MHz, see fig. 5.1, 5.2 and 6. The reference time  $t = 0$  is the leading edge of the line blank signal, the pulses of which have a duration of  $12 \mu\text{s}$  with a repetition time of  $64 \mu\text{s}$ . Decoupling inverter and gates 353/.. and 354/.. serve for signal generation in rhythm of line and picture, fig. 6.

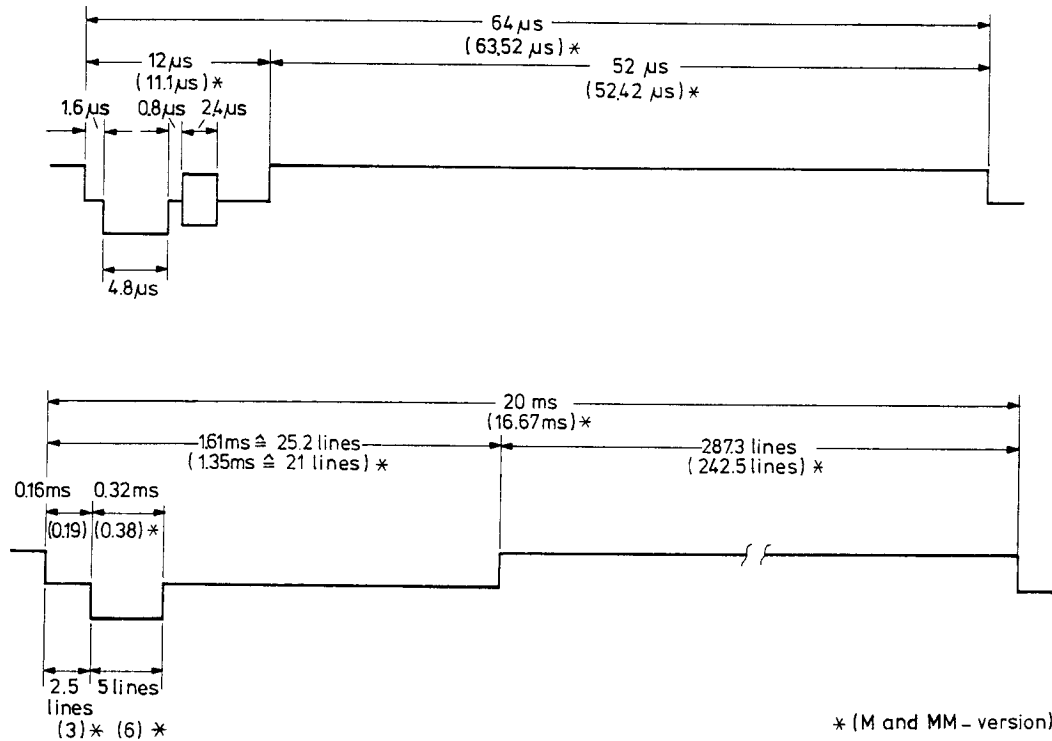

Fig. 4 Field and line raster signals

### 2.2.2. Horizontal pattern components: vertical lines and bars

With exception of the circle all the pattern components are normal square wave signals, the repetition frequencies of which are integer. From stage to stage, down to 1.25 times the line frequency the counters 356 and 355, fig. 7, divide the master frequency by 2. During 'line blank', the division is interrupted (although the clock frequency is further running), so that the pictures origine during the active line periods only.

- 2.2.2.1. The components for the **vertical lines and dots rows** are obtained by the flipflop 365, which in the rhythm of  $20 f_H$  is triggered by the counter output 356/6. After half a clock frequency ( $0.2 \mu s$ ) the master frequency resets the flipflop and thus determines the line width or the diameter of the dots.
- 2.2.2.2. The components for the **vertical bars** are taken from the outputs 3,2 and 6 of the counter 355. This signal is 8-4-2 coded. It is unsymmetrical with respect to the active part of the line. The period of the  $5f_H$  frequency is  $12.8 \mu s \hat{=} 1/5$  of  $t_H$ . The active line part is  $51.2 \mu s \hat{=} 4/5$  of  $t_H$ . The blanking signal of  $12 \mu s$  is finished delayed by  $0.4 \mu s$ , related to the outputs of the counter 355, corresponding to the period time of the clock frequency. The integer periods are finished by the same  $0.4 \mu s$  before the next blanking.

The prolongation of the blanking time is increased to  $6.6 \mu s$  by the flipflop 357 in connection with the gates 358 of the actual first bar of the signals. Similar to this the duration of the actual three last bars of the signals A, B, C is enlarged by  $0.4 \mu s$ .

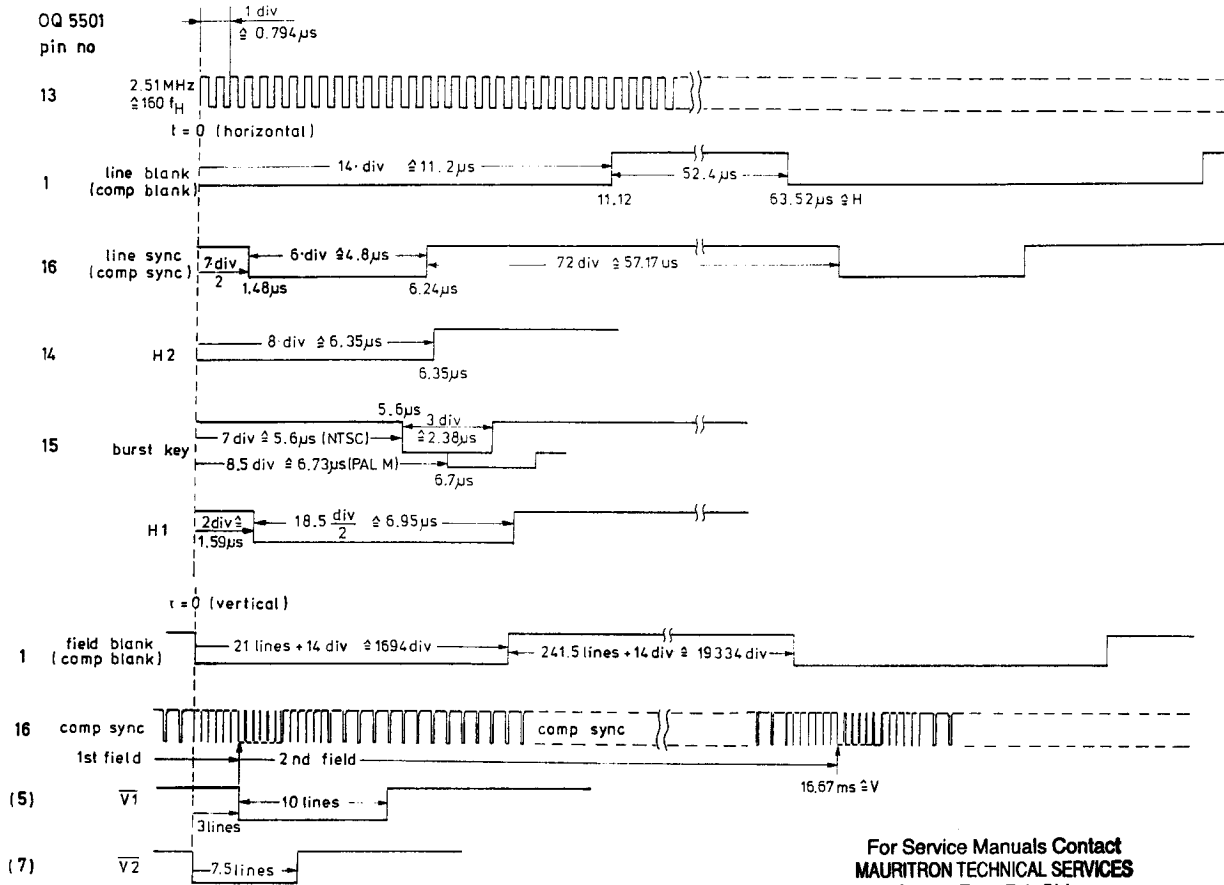

Fig. 5.1 Pulse diagram of OQ5501: NTSC norm

For Service Manuals Contact  
**MAURITRON TECHNICAL SERVICES**  
 8 Cherry Tree Rd, Chinnor  
 Oxon OX9 4QY  
 Tel:- 01844-351694 Fax:- 01844-352554  
 Email:- enquiries@mauritron.co.uk

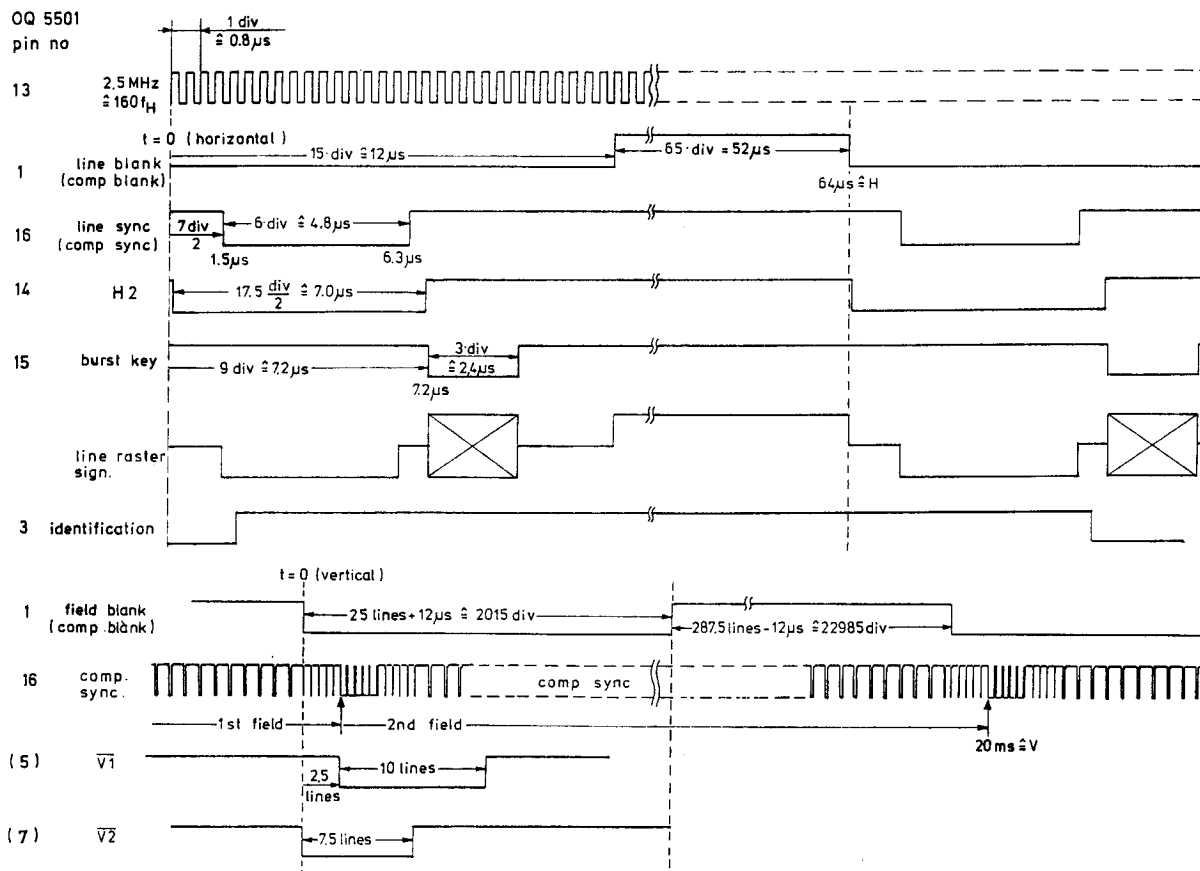

Fig. 5.2 Pulse diagram of OQ5501: CCIR norm

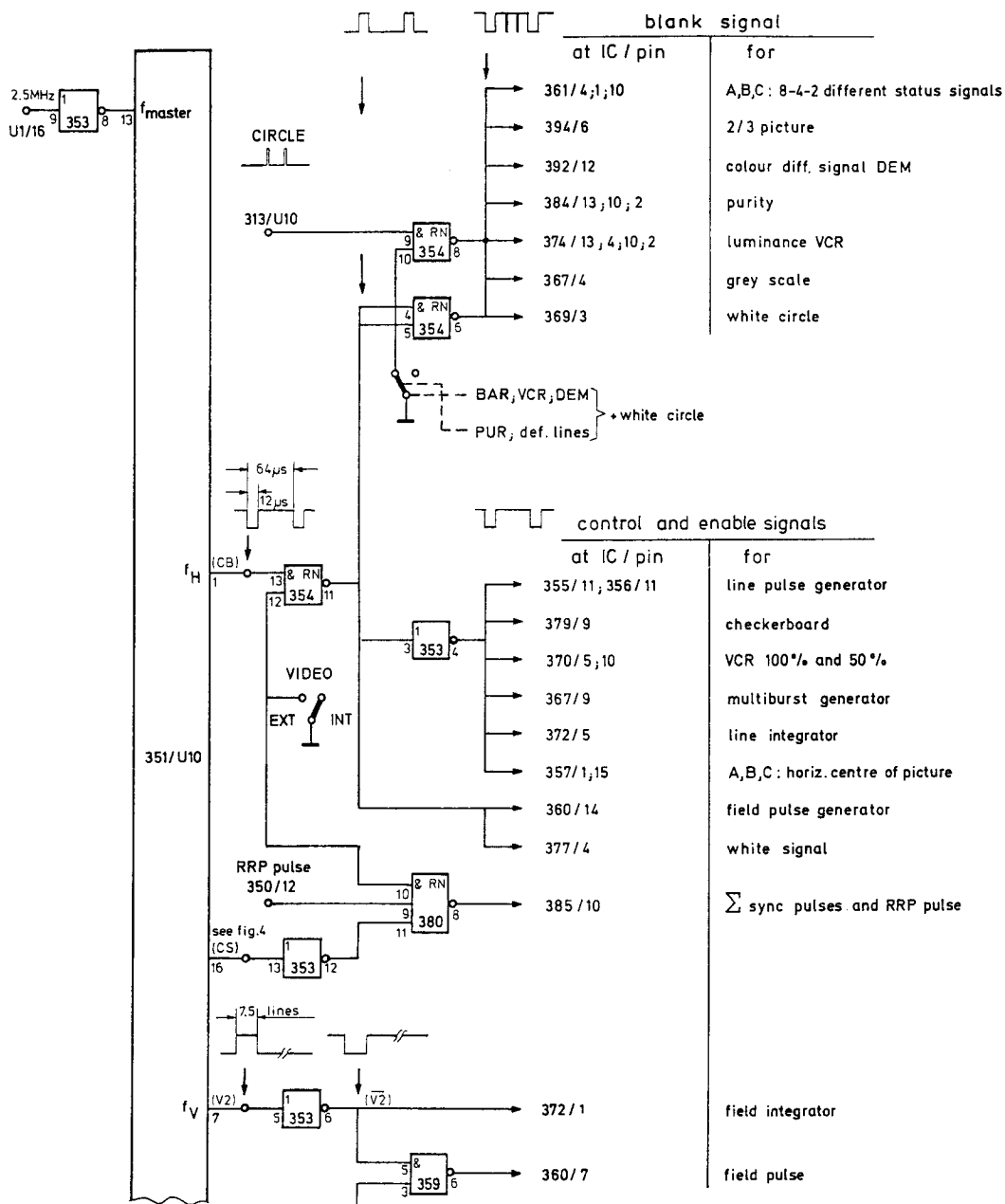

Fig. 6 Blanking and control signals

### 2.2.3. Vertical pattern components: horizontal lines, bars and fields

The square wave signals, fig. 8, are derived from the main pulse generator, fig. 6. The line frequency serves as clock frequency for the field pulse generator. The period times of the signals are defined as multiples of the line duration. Signals with period times of more than 1 line result in horizontal lines, bars and fields.

2.2.3.1. The components for the **horizontal lines and dots rows** are supplied by flipflop 362/5 and /6, fig. 35. Spaced by 24 line periods it is prepared by 362/9, triggered by the output of the counter 360/8 in the rhythm of 12 line periods and reset by the output of the main pulse generator 351/14.

2.2.3.2. The components for the **horizontal bars and fields** are achieved by frequency division, flipflop 363/...





#### 2.2.4. Staircase signals

The staircase signals for control of the multiburst oscillator, input unit 3 in fig. 9, are generated by summing the components of the generator 366/4/5/6/10/11 for the 5 vertical bars with different frequency groups (definition lines).

- 2.2.4.1. **In line rhythm** the inputs of the inverters 371/11/9/5/13 progressively receive H-level and thus 'switch' the concerning resistors, connected to the summing point  $\Sigma P1$ , via 371/... single-ended to ground. By this the summing point, being at a dc level of 4.2 V, is deprived of current, compensated by the input stage. In principle this input circuitry of the multiburst oscillator is a current/voltage/current converter, fig. 9.

In VCR mode the same multiburst oscillator generates the frequency groups for the horizontal bars.

- 2.2.4.2. **In rhythm of the picture raster frequency** 3 resistors are progressively parallel switched to the summing point via transistors 301 to 303. This current staircase superimposes the bars 2, 3 and 4 by frequency groups over the whole TV frame. A start and stop signal defines the position of the bars of frequency groups in vertical direction.
- 2.2.4.3. **The graduated signals for the greyscale** are formed by progressive subtraction of current  $i_5$ ,  $i_6$ , and  $i_7$ , see bottom of fig. 13, defined by resistors 688 to 690. During the active line time the resistors are switched to ground by the 8-4-2 coded signals A, B and C.

For Service Manuals Contact  
**MAURITRON TECHNICAL SERVICES**  
 8 Cherry Tree Rd, Chinnor  
 Oxon OX9 4QY  
 Tel:- 01844-351694 Fax:- 01844-352554  
 Email:- enquiries@mauritron.co.uk

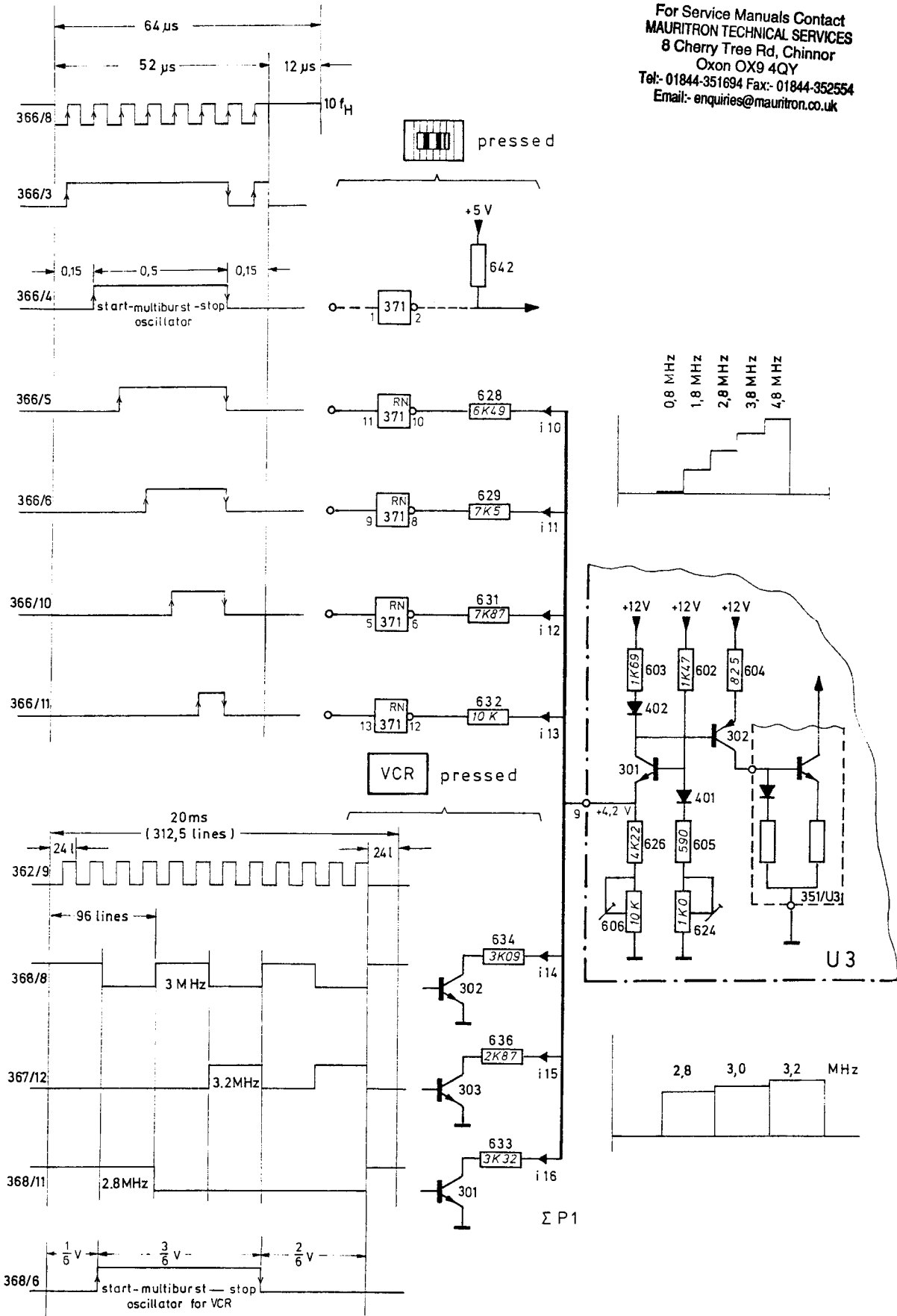

Fig. 9 Control signals for multiburst oscillator

### 2.2.5. Circle components, fig. 35

The circle is composed by two pulses, which at the intersection line/circle are two times actuated by the comparator during the active line time. With increasing number of lines in the upper part of the frame e.g. the distance between two pulses is automatically augmented with respect to the central row.

- 2.2.5.1. **Double integration** by the line- and field integrators, fig. 10.1 and 10.2, 304, 306 and 307, 308, causes parabola in line and picture deflection. The control is organized by the enable signals (H-level) 351/1 and 351/7 via the gates 372/6 and 372/3. These gates are disabled, if the CIRCLE pushbutton is not pressed.

The addition is achieved via resistors 663-665.  
The ellipticity is adjusted by potmeter 664, fig. 10.1.

- 2.2.5.2. **Forming the circle**, fig. 10.2. The comparator 309-313 is adjusted by 671 within the voltage divider 672/669 so that transistor 309 is cut off and 310 conducts. When the added parabola voltages are exceeding the comparator level, the current of the difference stage is taken over by transistor 309. Approaching the comparator level from higher voltages the same effect results in reverse direction. So at the common cathode pulses of half the diode forward voltage origine, fig. 10.1. The different thickness of the circle, when selecting white or black circle, is achieved by the differentiations within the decoupling stages 312 and 313.

- 2.2.5.3. **Multiburst signal**

The pulses which generate the stepwise increasing current into pin 9/U3 are shown in fig. 9. Just as this current the multivibrator frequency changes too (5 groups or 3 groups).

The multivibrator, fig. 28, is a symmetrical emitter-coupled oscillator. The transistors 351/11 and 351/14 work as normal amplifier and 351/13 and 351/12 as emitter-follower. By increasing (decreasing) the base-voltage of 351/5 and 4 to a higher (lower) level than 351/6 and 3 the whole current passes through 351/13 and 351/12 (no oscillation) [through 351/11 and 351/14 (oscillation)]. Oscillation starts if input 8/U3 is clamped to +5,8 V by the zener-diode 407/U10. The blanking and start-stop signal is generated by the AND-gate 368/6. The frequency of 4.8 MHz is adjustable by 606/U3 and 0.8 MHz by 624/U3. The adjustment of the multiburst amplitude is achieved by 631/U3.

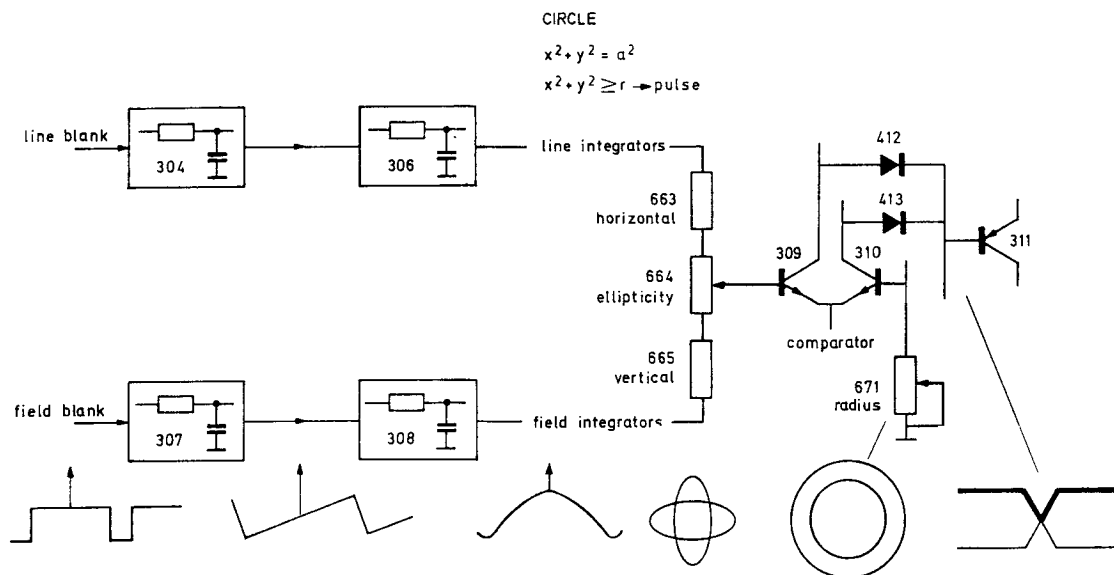

Fig. 10.1 Forming the circle control pulse

For Service Manuals Contact  
**MAURITRON TECHNICAL SERVICES**  
 8 Cherry Tree Rd, Chinnor  
 Oxon OX9 4QY  
 Tel:- 01844-351694 Fax:- 01844-352554  
 Email:- enquiries@mauritron.co.uk

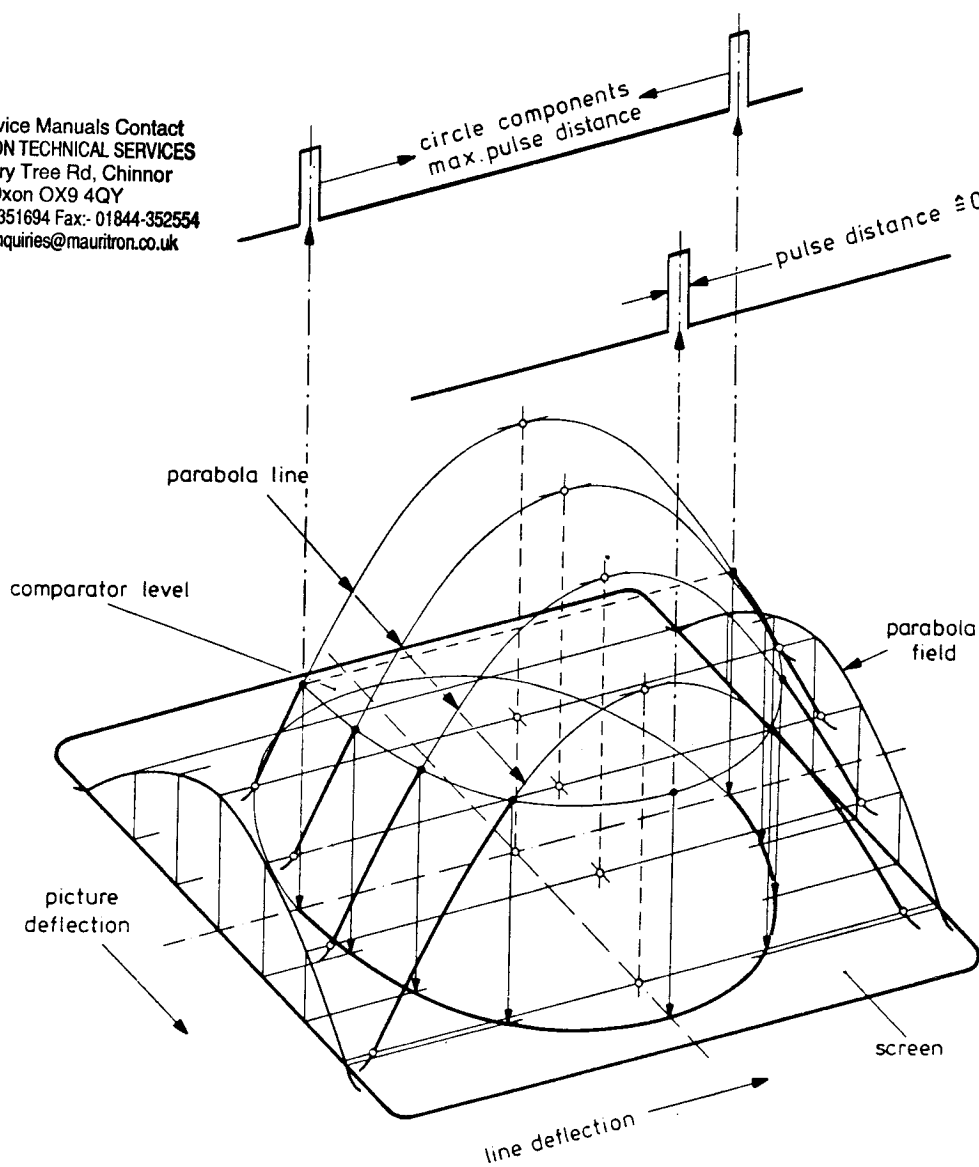

Fig. 10.2 Forming the circle

### 2.2.6. Synthesis of the Black/White test patterns, figs. 11 and 12

The test patterns are generated by addition of horizontal and vertical pulse groups, circle pulses, staircase pulses and the ac-coupled multiburst-frequencies (via resistor 692/U10).

Fig. 11 shows the connections between the required components for activation and inhibition of the chosen test pattern and the connection to the digital summing junction  $\Sigma 2$ . This summing junction  $\Sigma 2$  is connected to the main summing junction  $\Sigma 3$  via the resistor 687/U10, determining the amplitude. The potential of  $\Sigma 3$  is +5 V; 100 % White means no current through resistor 687/U10 and high level at  $\Sigma 2$ .

#### Pushbutton "checkerboard"

The gates 379/6, 380/6, 377/3 (see fig. 11) are inhibited, because of low level at one input of each gate. The NAND-gate 381/8 couples the square wave signals  $5 f_H$  (393/9) and  $1/3.25 V$  (393/10) to the summing junction  $\Sigma 2$ , if no other pushbutton (VCR, white) is depressed. The AND-gate 393/8 combines the horizontal checkerboard pulses  $5 f_H$  with the vertical  $1/3.25 V$  pulses to 8 vertical checkerboard-bars and 6 horizontal one's. White pattern squares are generated, if  $5 f_H$ ,  $1/3.25 V$  and the blanking signal  $f_H$  have high level. So the NAND-gate 379/8 gets low level, NAND-gate 381/8 high level and the current in resistor 687/U10 is inhibited.

#### Pushbutton "dots"

The NAND-gate 380/6 combines the  $20 f_H$  and  $1/13 V$  pulses resulting in a signal with 13 horizontal lines (distance 24 lines) of 17 pulses (pulse width 200 ns, pulse distance  $3.2 \mu s$ ).

The dots are the intersections of the horizontal and vertical crosshatch lines.

#### 2.2.6.3. Pushbutton "crosshatch"

The inverted signals  $\overline{20 f_H}$  and  $\overline{1/13 V}$  are connected via NAND-gate 380/12. Out of this connection 17 vertical lines are generated (distance  $3.2 \mu s$ ), if  $\overline{20 f_H}$  has low level and 13 horizontal lines (distance 24 lines), if  $\overline{1/13 V}$  has low level. Gate 377/3 inverts this crosshatch signal to the necessary polarity.

#### 2.2.6.4. Pushbutton "circle"

The NAND-gates 379/6 and 379/12 are enabled. The circle pulses (see chapter 2.2.5 and fig. 10.2) change their distance from line to line according to the function of a circle. The circle pulses cut off the current through resistor 687/U10 (379/6, 381/8 and 378/3), resulting in a white circle on a black field.

#### 2.2.6.5. Pushbutton "circle" and WHITE

The NAND-gate 377/6 is activated thus switching the summing junction  $\Sigma 2$  to high during the active line period by the pulse sequence " $\overline{1 f_H}$ " (via 378/6). The circle pulses 313/C pass gates 379/12 and 378/3 as 378/1 has high level because of inhibited gate 381. The circle pulses interrupt the high level of  $\Sigma 2$ . So a white field with a black circle is generated.

#### 2.2.6.6. Pushbuttons "circle" and BL/WH

The gates 381 and 378/3 are combining the circle pulses with all test-pattern signals generated in this section (fig. 11). In the white squares of the checkerboard circle pulses 312/C are engraved by 379/6 (pulse width 312/C being larger than 313/C). In this engraved black circle the white circle 313/C is added by 379/12 and 378/2.

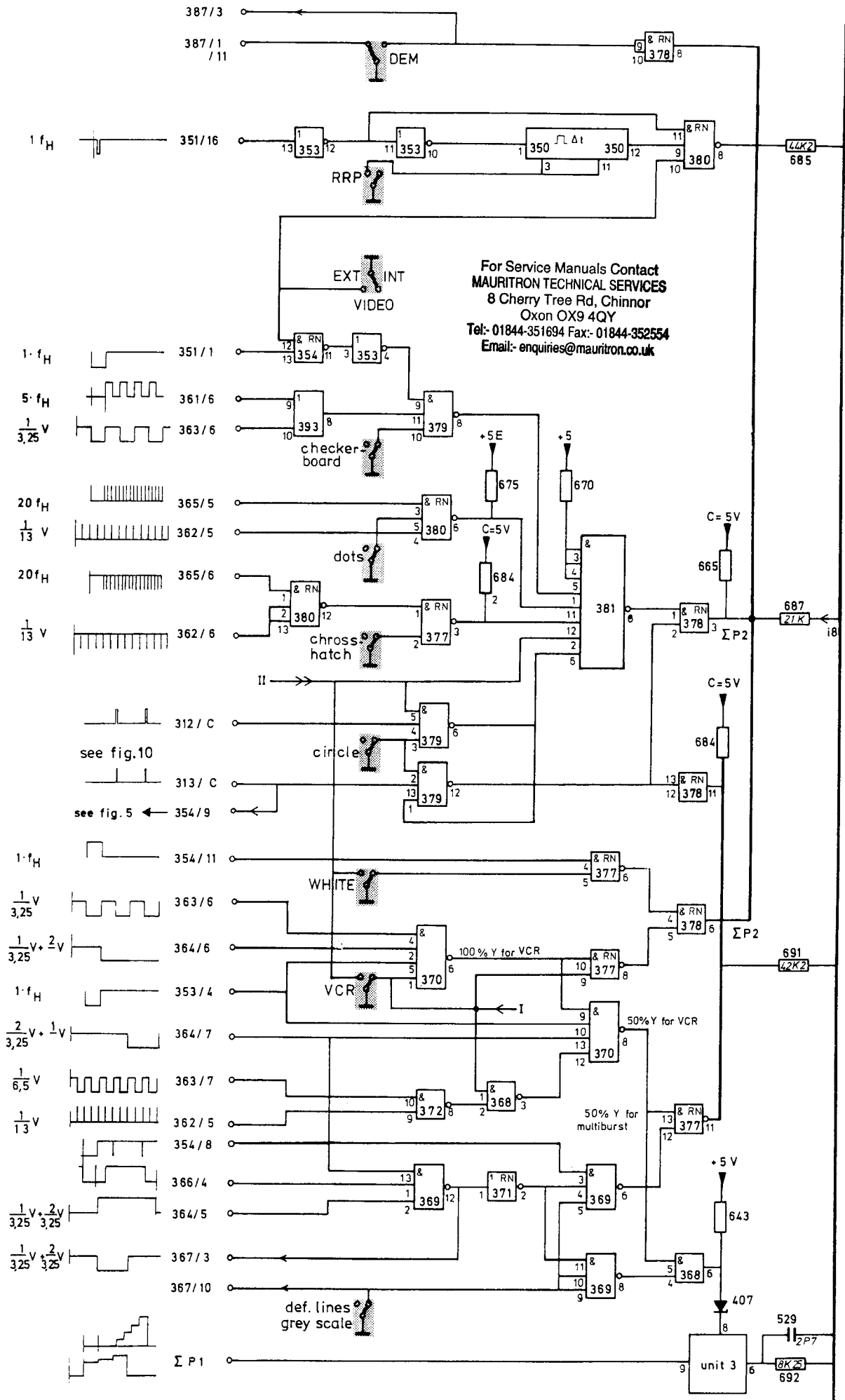

Fig. 11 Digital addition of the BL/WH pattern

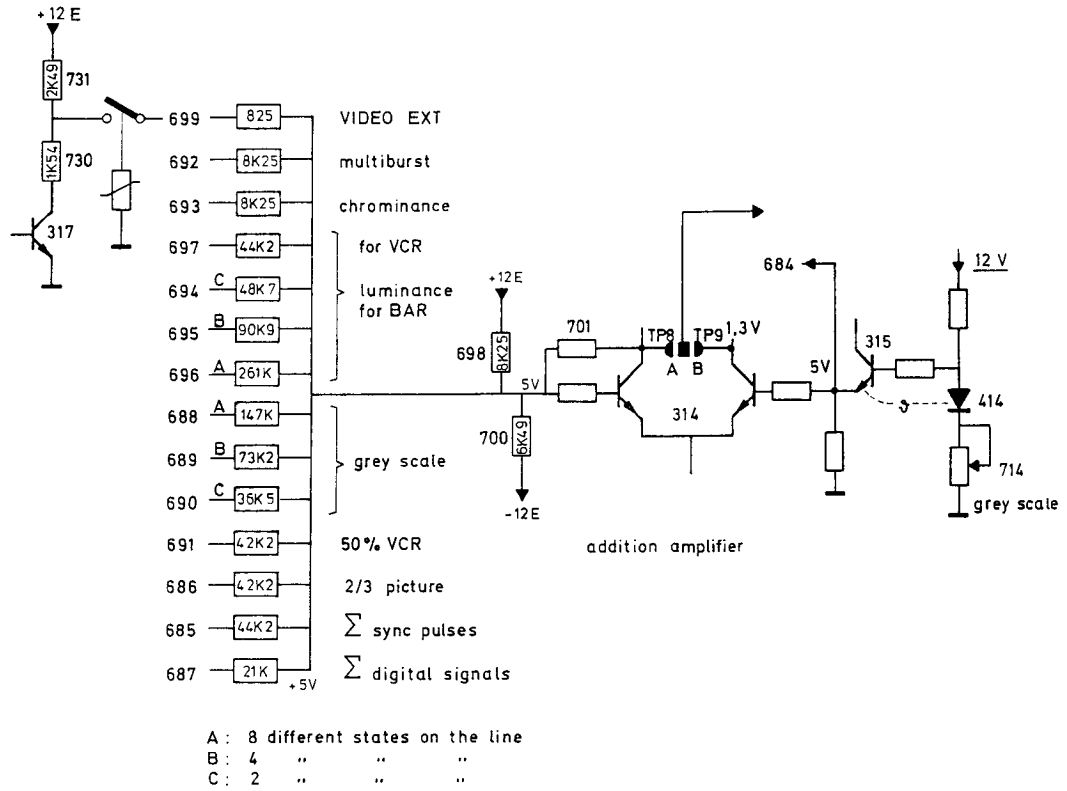

Fig. 12 Summing and scale factor of patterns and signals

#### 2.2.6.7. Pushbutton WHITE

The NAND-gate 381 is disabled by low level at pin 2. During the active line time the signal " $\overline{1} f_H$ " obtains high level at the summing junction  $\Sigma P2$ , resulting in 100 % white.

#### 2.2.6.8. Pushbutton "definition lines/grey scale"

The NAND-gates 370/6, 377/8 and 368/3 are inhibited by the VCR switch (see fig. 11); the output level is high. By combination of the vertical signals 364/7 and 364/5 the vertical start-stop signal for the multiburst oscillator in 368/6 is generated. The horizontal start-stop signal is given by the signals in fig. 9. The composite blanking signal 353/4 stops the luminance during the blanking time. Above mentioned signals are combined with the composite blanking signal 354/8 (signal includes the circle blanking, if circle push-button is depressed) to the 50 % -Y signal (luminance) in the NAND-gate 377/11. The current 50 % -Y is coupled by resistor 691/10 to  $\Sigma P2$ . The grey scale is described in 2.2.4.3.

For Service Manuals Contact  
**MAURITRON TECHNICAL SERVICES**  
 8 Cherry Tree Rd, Chinnor  
 Oxon OX9 4QY  
 Tel:- 01844-351694 Fax:- 01844-352554  
 Email:- enquiries@mauritron.co.uk

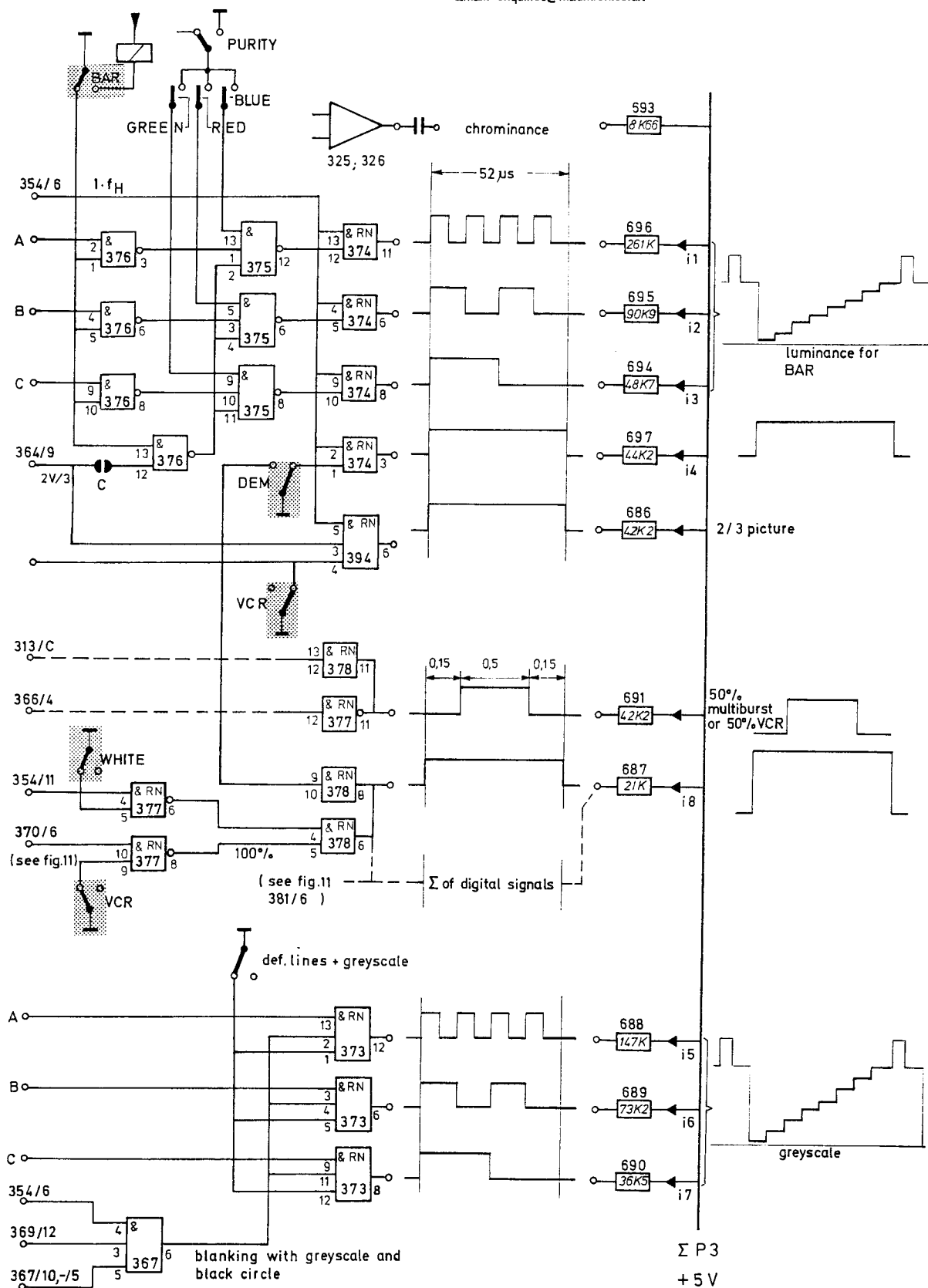

Fig. 13 Greyscale generation



## 2.2.7. Colour part

### 2.2.7.1. Colour carrier frequency ( $f_{sub}$ )

The colour carrier is X-tal stabilized. The colour carrier is the reference frequency for the line-master-frequency (phase locked loop circuitry, see 2.2.1.) and the source for the colour modulators and the colour sync signal.

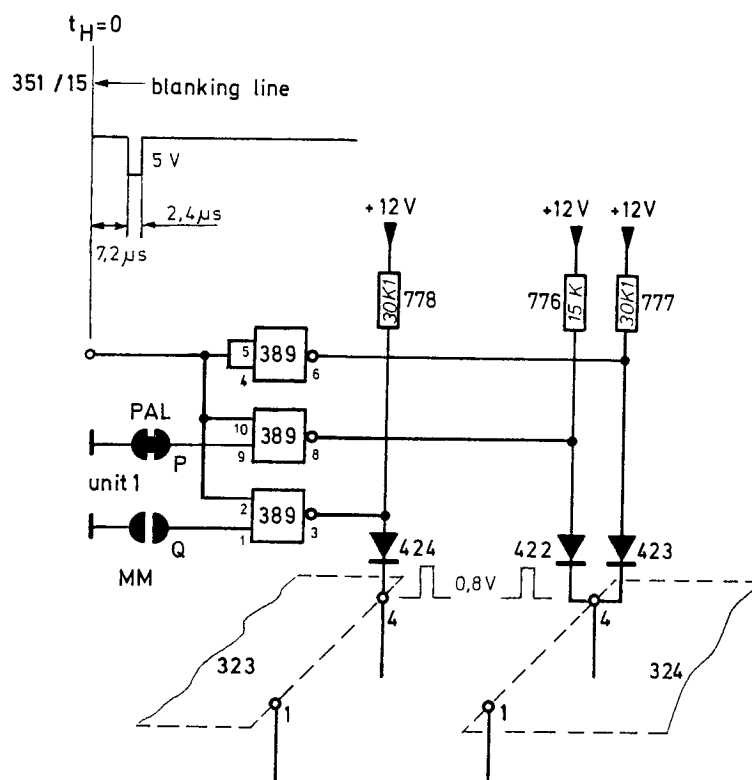

Fig. 14 Generation of the colour sync signal

### 2.2.7.2. Colour sync signal (burst), fig. 14

The burst is generated by activation of the colour modulators with the burst-key signal during blanking time. The burst includes 10 sine wave periods with alternating phase angle of  $135^\circ$  and  $225^\circ$  ( $180^\circ \pm 45^\circ$ ) from line to line.

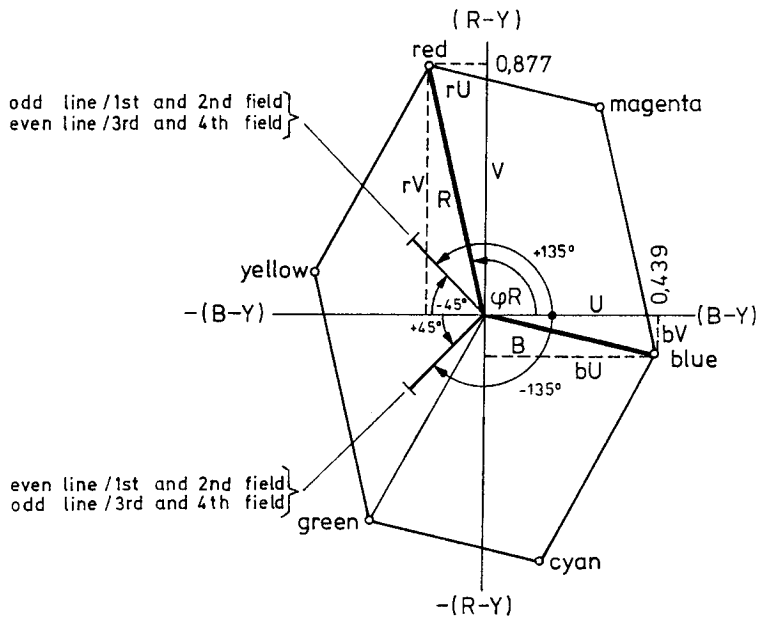

Fig. 15 Phase diagram of the primary and complementary colours and of the colour sync signals

For Service Manuals Contact  
**MAURITRON TECHNICAL SERVICES**  
 8 Cherry Tree Rd, Chinnor  
 Oxon OX9 4QY  
 Tel: 01844-351694 Fax: 01844-352554  
 Email: enquiries@mauritron.co.uk

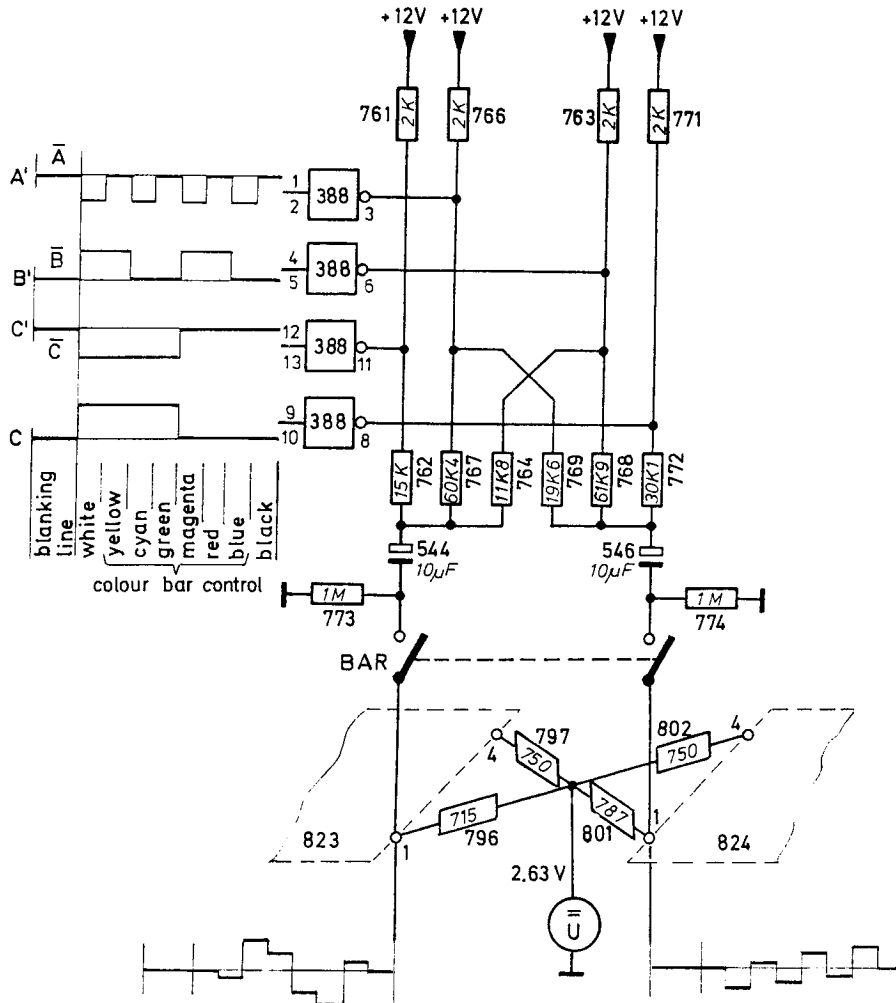

Fig. 16 Colour bar matrix, control signal and modulator input

## 2.2.7.3. RGB signals, fig. 17

The basic relationship between the luminance (Y) and the 3 primary colours red (R), green (G) and blue (B) is given by the following definition:

$$Y = 0.3 \cdot R + 0.59 \cdot G + 0.11 \cdot B$$

The colour bar pattern consists of these 3 primary colours, the 3 complementary colours cyan ( $\bar{R}$ ), magenta ( $\bar{G}$ ) and yellow ( $\bar{B}$ ), black and white (8 bars, fig. 16).

The colour modulation is performed by means of the colour difference signals (R-Y) and -(B-Y), whereby

$$(R-Y) = 0.7 \cdot R - 0.59 \cdot G - 0.11 \cdot B$$

$$-(B-Y) = 0.3 \cdot R + 0.59 \cdot G - 0.89 \cdot B$$

The colour difference signals are generated by a resistor matrix (fig. 16), which is obtained by means of the pulse signals A, B, C. The addition of (R-Y) and -(B-Y) results in a term missing the green, therefore no green colour component has to be modulated. The whole colour information is inherent in the two colour difference signals (R-Y) and -(B-Y).

Fig. 17 shows these signals (R-Y) and -(B-Y) which are modulating the colour subcarrier.

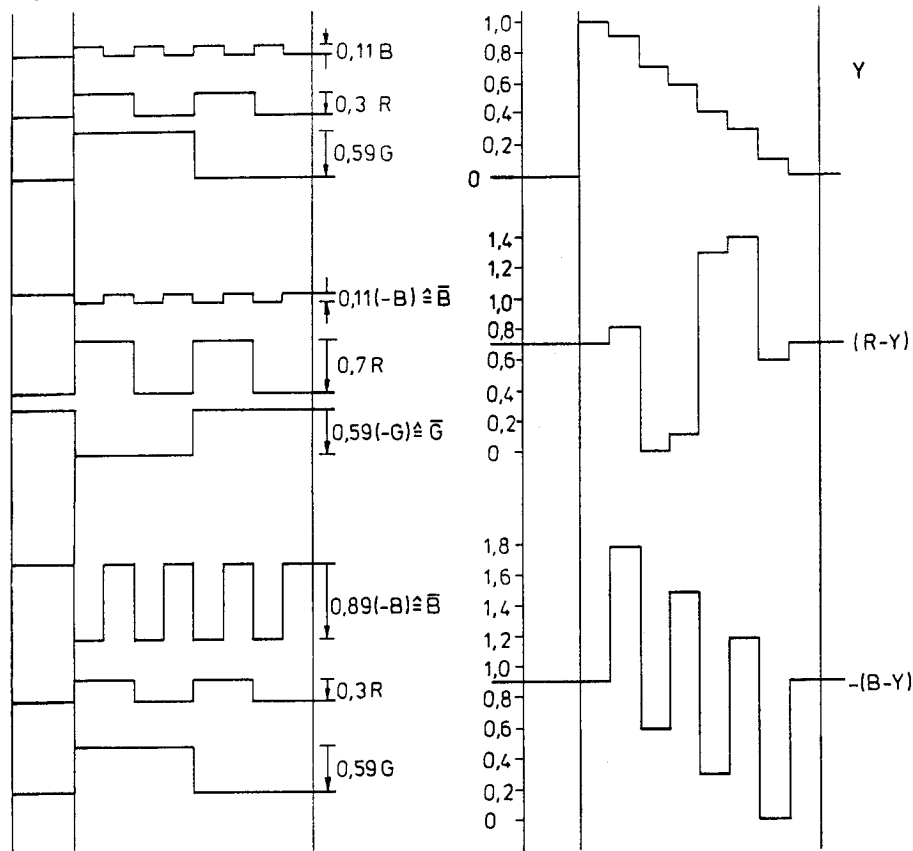

Fig. 17 Synthesis of the Y, (R-Y) and (B-Y) signals out of the RGB components

## 2.2.7.4. RRP signal (receiver recognition pulse)

This pulse is a gap within the line sync pulse (see 4.4.7). It serves for identification, from which source signals are sent to the TV receiver (VCR) and whether the video bandwidth has to be reduced (for VCR-source) or not (automatic commutation in modern TV sets).

The RRP pulse has a width of 530 ns starting 3.3  $\mu$ s after beginning of the sync pulse. This pulse is coupled to the normal "composite sync" signal by input 9 of the NAND-gate380/8. The RRP pulse is originated out of the sync pulses by means of two one-shots (pos. 350). The start time of 3.3  $\mu$ s is destined by the time constant of resistor 682 and capacitor 550, the stop time of (3.3  $\mu$ s + 530 ns) is given by resistor 683 and capacitor 551.

## 2.2.8. Synthesis of the chroma signals, fig. 18

- 2.2.8.1. The **chroma modulator** (fig. 18) consists of 2 output-coupled four quadrant multiplier 323 and 324/U10. The plus and minus signs are pointing out the directions of the input signals with respect to the outputs. The colour carrier frequency ( $f_{sub}$ ) having passed the phase switches 327, 328 are applied to the chroma modulators 323 and 324, whereby the phase shift of  $f_{sub}$  at the two different modulator inputs is  $90^\circ$ . The colour carrier frequencies phase shifted by  $90^\circ$  are multiplied with the colour difference signals (R-Y) and  $-(B-Y)$  in the (R-Y) and (B-Y) modulator. The correct amplitude relationship [(R-Y) to (B-Y)] is adjusted by potmeter 811, the residual colour carrier by 800 and 809.

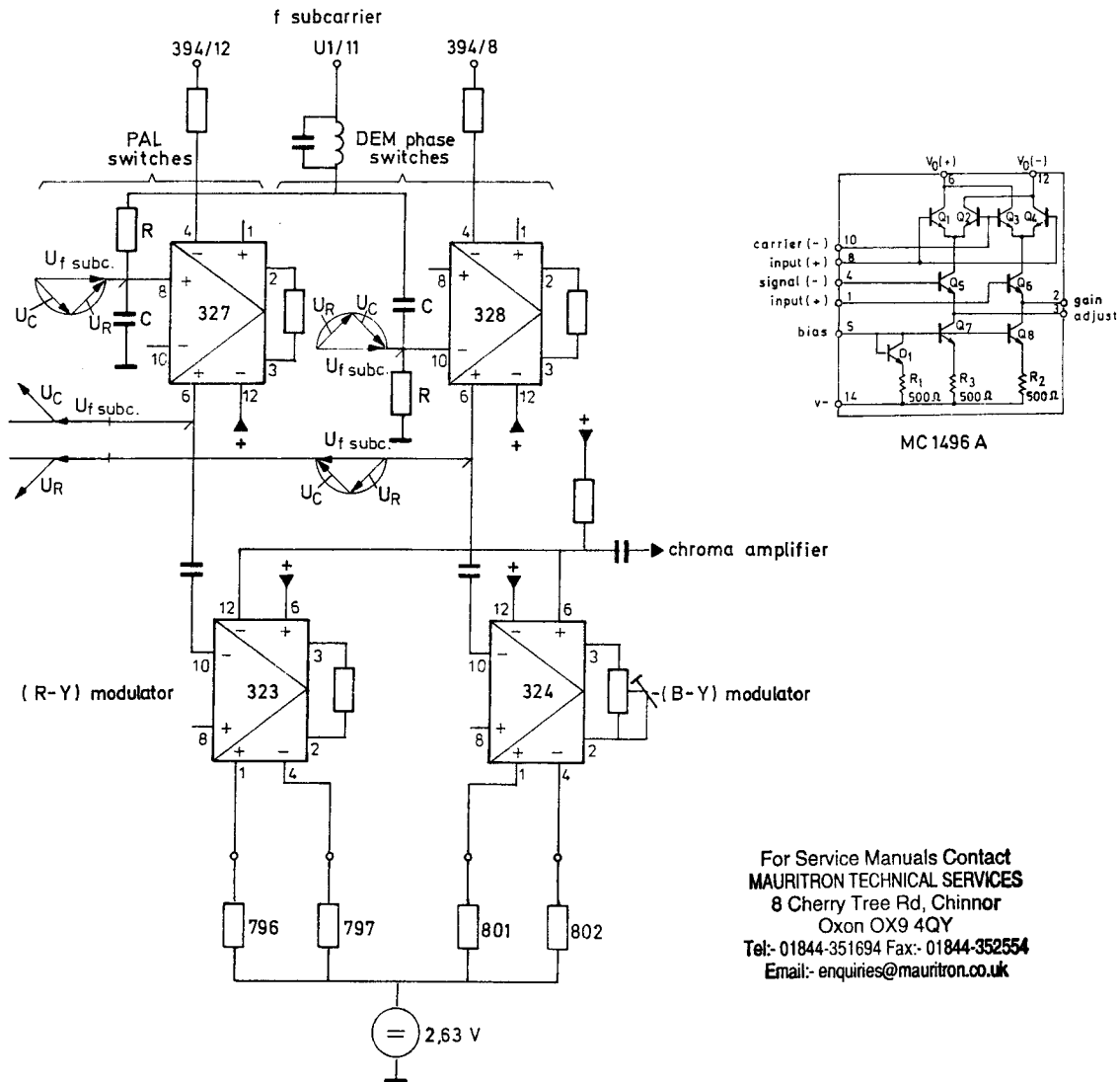

Fig. 18 Colour difference modulators and phase switches of the colour carrier frequencies

### 2.2.8.2. PAL and DEM phase switch

The colour carrier frequency is divided into two components,  $90^\circ$  phase shifted with respect to each other by means of an RC low pass filter and the CR high pass filter ( $\pm 45^\circ$  for  $f_{resonance} = f_{sub}$ ). The phase shifted frequencies are applied to different input polarities, 327/8 ("+" input) and 328/10 ("-" input).

The phase of the outputs 327/6 and 328/6 can be switched to  $0^\circ$  or  $180^\circ$  depending on the digital signals at the inputs 327/4 and 328/4. Low level e.g. at 327/4 cuts off the dc current source Q5 and so the transistors Q1 and Q2 (see fig. 18, detail MC 1496 A), the whole current of Q7, Q8 passes Q6. The output pin 6 obtains the polarity of Q3, and the negative polarity of Q1, if there is a high level at the input 327/4.

For Service Manuals Contact  
**MAURITRON TECHNICAL SERVICES**  
 8 Cherry Tree Rd, Chinnor  
 Oxon OX9 4QY  
 Tel: 01844-351694 Fax: 01844-352554  
 Email: enquiries@mauritron.co.uk

2.2.8.3. Monochrome pattern (purity), fig. 19

In combination with depressed PUR pushbutton and primary colour pushbutton the chosen colour is generated with 75 % saturation. Activating one of the primary colour switches originates two dc voltage components by means of three resistors; the components are rU, rV or gU, gV or bU, bV and they are applied to the "+" or "-" inputs of the (R-Y) and (B-Y) modulators. If the PUR- and one of the primary pushbuttons is pressed, the 90° phase shifted subcarrier frequencies are modulated by the corresponding U- and V- dc voltages, which are applied via decoupling diodes. If no pushbutton PUR is pressed, the centre points of the matrix is set to 0V, that means the matrix is out of operation.

The luminance matrix 694-696, fig. 13, generates the luminance of the 3 primary and 3 complementary colours and the colour bar luminance.

The colour purity luminance is applied to the summing junction by disabling the corresponding AND-gates 375/12, 375/6 and 375/8 by the purity contacts.

The automatic generation of the colour bar luminance staircase follows by releasing the ABC signals via the AND-gates 376/3, 376/6 and 376/8.

During line-return-time the blanking signal 354/6 stops the addition of the luminance staircase. In the same way, during active line time the circle pulses combined with the blanking signal reduce the staircase value to black level (fig. 6).

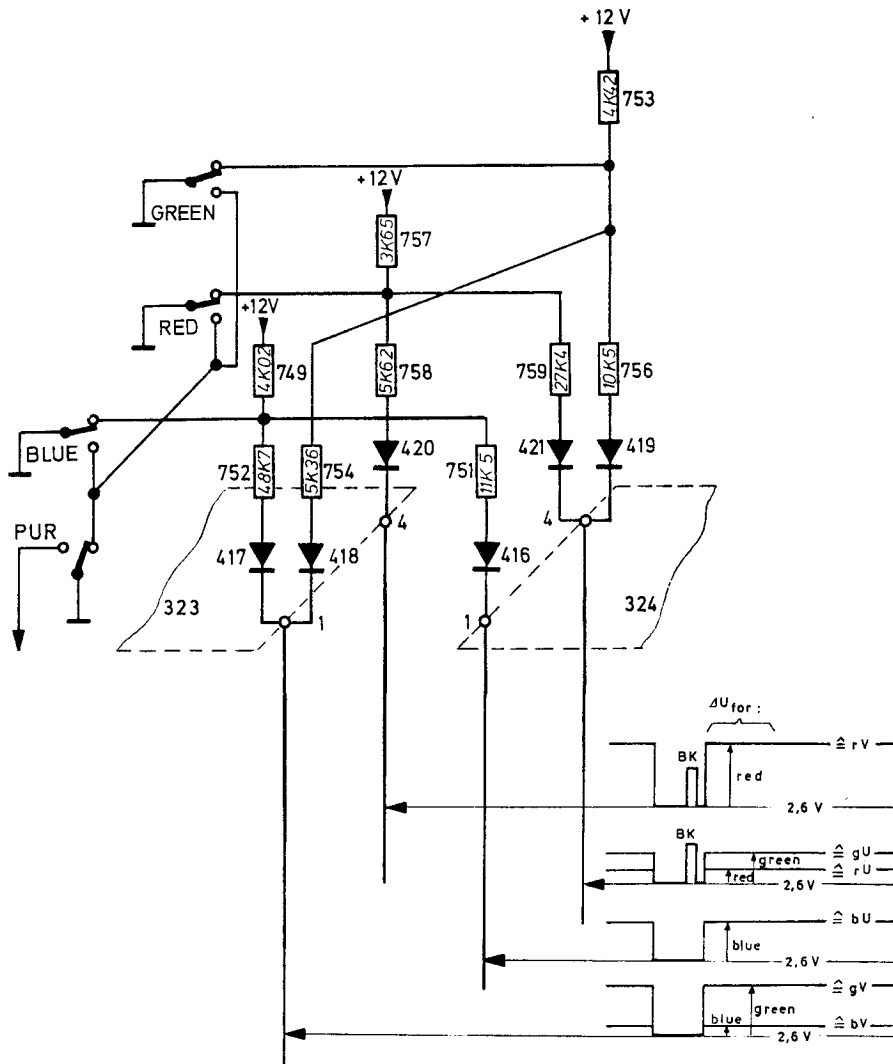

Fig. 19 Matrix of the monochrome pattern red, green and blue

2.2.8.4. Pushbutton DEM depressed, fig. 20.1

The summing junction  $\Sigma P2$  has low level via AND-gate 378/8, fig. 11.  
 The luminance of the whole DEM pattern is 50 % white, applied to the summing junction  $\Sigma P3$  via the AND-gate 374/3 (see fig. 13). In the first bar of the DEM pattern the component  $(G-Y) = 0$ . The second bar has no colour information at all. The third bar consists of a  $(R-Y)$  component only (but NTSC-coded) and the fourth bar consists only of the  $(B-Y)$  component (but PAL-coded).  
 The lower third part of the field serves as reference for all bars.  
 The necessary  $(R-Y)$  and  $(B-Y)$  pulses are applied to the colour matrix by the resistors 783 and 784 (fig. 20.1). Pulse B is one of the driving signals, the other one is a NAND combination of pulse C and B. In the phase-switches 327, 328 the colour carrier frequencies ( $f_{sub}$ ) are switched to the required NTSC- or PAL-coded mode by means of the AND-gates 394/8 and 394/12.

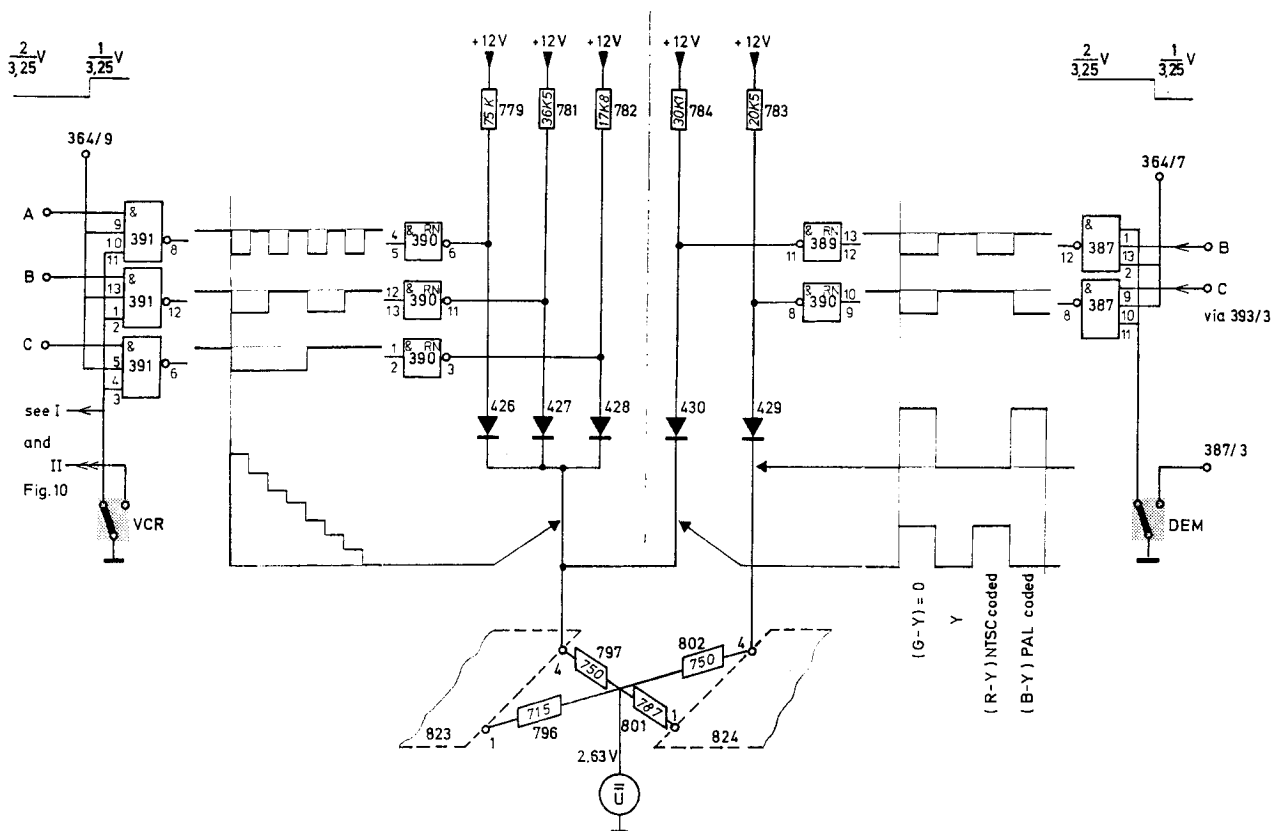

Fig. 20.1 Control of the colour modulator for DEM and VCR

For Service Manuals Contact  
**MAURITRON TECHNICAL SERVICES**  
 8 Cherry Tree Rd, Chinnor  
 Oxon OX9 4QY  
 Tel:- 01844-351694 Fax:- 01844-352554  
 Email:- enquiries@mauritron.co.uk

## 2.2.8.5. Pushbutton VCR depressed, fig. 20.1

The colour saturation staircase of the lower part of the VCR pattern is generated by driving the colour matrix by the signals A, B, C. The (R-Y) modulator gets dc-components from resistors 779, 781, 782, the (B-Y) modulator is inhibited. The (R-Y) saturation staircase is combined with a luminance of 50 %. The NAND-gates 391/8, 391/12 and 391/6 combine the blanking signals 2/3 V, 1/3 V from 364/9 with the A, B, C-signals.

The depressed VCR pushbutton (fig. 11) enables the NAND-gates 370/6, 377/8 and 368/3 and disables the NAND-gates 379/6 and 381/8. The signals 363/6 and 364/6 are combined in 370/6 to a 1/6 V pulse, which switches the 100 % white to  $\Sigma P2$ . The following 3 horizontal bars are separated by a "one-line"-blanking pulse (black luminance). This special signal is generated by combination of the signals 363/7, 362/5, 364/7 and 353/4 and helps to see the limits between the 3 horizontal bars of frequency groups (2.8, 3.0 and 3.2 MHz). The required composite-blanking signal 354/8 (signal includes circle blanking pulses, if pushbutton "circle" is depressed) is coupled via the NAND-gate 369/6.

The start-stop-signal for the VCR frequency groups is generated by combination of 363/6, 364/7 and 364/6 in the NAND-gates 370/6 and 370/8. This start-stop-signal is coupled by 368/6 to U3 (multiburst oscillator).

The corresponding driving signal for the multiburst oscillator is generated in  $\Sigma P1$  (see fig. 9).

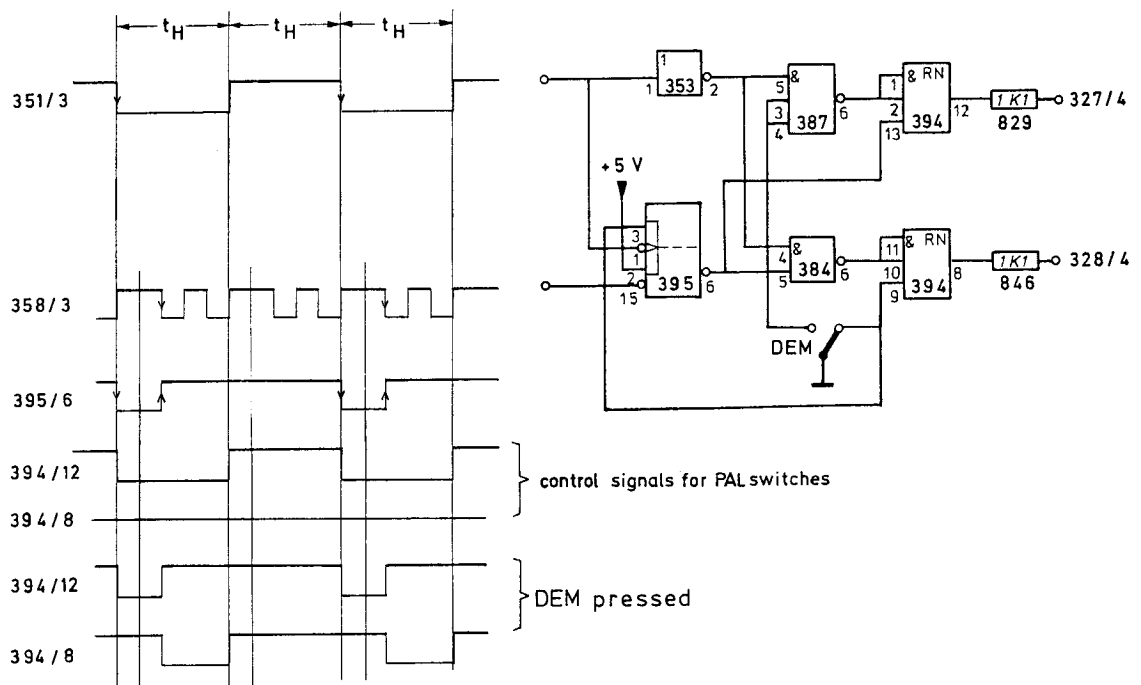

Fig. 20.2 Control of the PAL and DEM phase switches

## 2.2.8.6. Pushbutton COLOUR BAR depressed

The resistor matrix for the generation of the (R-Y) and (B-Y) colour difference signals is shown in fig. 16. These signals are coupled via capacitors 546 and 544 to the inputs of the modulators. The generation is done by means of the signals  $\bar{A}$ ,  $\bar{B}$ ,  $\bar{C}$  and C in the shown resistor matrix.

The corresponding luminance staircase is generated by the summing resistors 694, 695, 696; the driving signals are A, B, C.

The colour difference signals modulate the  $90^\circ$  phase-shifted colour carrier frequencies. The resulting chroma signal is separated from all dc components by the coil 889. The amplified and calibrated chroma signal is coupled to the summing junction  $\Sigma P3$  by 530 and 693, whereby the luminance staircase is fed-in via 694, 695, 696.

## 2.2.9. Chroma and video channels

2.2.9.1. The **chroma amplifier** is a differential amplifier with an input and output buffer (emitter follower). The chroma signal is fed-in via the emitter 326/10 and capacitor 556 and added to the dc emitter current of the differential amplifier. A dc current applied to the feed-back resistor 813 + 819 enables to change the current-balance through the two transistors. For a constant ac/dc current ratio the chroma amplitude at 326/6 can be adjusted by changing the applied dc current. The calibration to the correct chroma amplitude is done by potmeter 823 with depressed CHROMA AMPL pushbutton 100 %. Combined CHROMA AMPL pushbutton action of 50 % and 0 % decreases the chroma amplitude by increased dc current. Combined pushbuttons 100 % and 50 % result in nominal 75 %, 50 % and 0 % in nominal 25 % amplitude of the chroma amplitude with 75 % saturation. When none of the buttons is pressed the amplitude is 130 % approximatly.

2.2.9.2. The **VIDEO EXT** input is ac-coupled. A sync-separate circuitry (535, 724, 725, 726 and 316) separates a sync-clamp-pulse in order to clamp the external signal to ground by transistor 317. The external signal is buffered by transistor 318. By scaling resistors 730 and 731 the accurate signal level is fed into the summing junction  $\Sigma$ P3. The clamped external signal is coupled by reed-relay 891 and the resistor 699 to  $\Sigma$ P3.

2.2.9.3. The input  $\Sigma$ P3 of the **video summing amplifier** has a level of +5V, because of the +5V reference of pin 9/314. Within a small range this level can be varied by potmeter 714 in order to get the same level range for the two video polarities at pin 7 and pin 9. Diode 414 compensates the temperature coefficient of the base-emitter junction of transistor 315. This video summingamplifier is a differential amplifier. Choosing either soldering link A or B changes the video modulation of the RF signal (see 4.5.1.). The differential amplifier 314/1, 2, 3, 12, 13, 14 adapts the video signal to the required input range of the RF modulator.

The +5V reference level mentioned above is the reference level for all summing resistors too (resistors for  $\Sigma$ P3). This circuitry prevents digital spikes of the normal +5V power supply from influencing the video amplifier.

2.2.9.4. The **video amplitude control** amplifier is designed similar to the chroma amplifier. The current balance of the differential amplifier 320, 321 is controlled by different dc currents fed into the feed-back resistor 736. The video signal is decoupled by the emitter follower 319 and added to the constant dc emitter current of 320, 321 via 540 and 733. The ratio of the ac/dc-current through 320 and 321 is constant, independent of the current balance.

The calibrated video amplitude of  $1V_{pp}$  into  $75 \Omega$  is determined by the current through 737, which is fed-in by switching the VIDEO AMPL potentiometer to the stop-position. This value is calibrated by resistor 747 paralleled to 739. The video amplitude variation from 0 to  $1.5V_{pp}$  can be done by the VIDEO AMPL potentiometer. The amplitude at 735 is fed-out by the emitter follower 325 and, ac-coupled via 542, to the power emitter follower 322. The video signal is available at the BNC connector VIDEO OUT being ac-coupled. The output impedance is  $75 \Omega$ .

For Service Manuals Contact  
**MAURITRON TECHNICAL SERVICES**  
 8 Cherry Tree Rd, Chinnor  
 Oxon OX9 4QY  
 Tel:- 01844-351694 Fax:- 01844-352554  
 Email:- enquiries@mauritron.co.uk



### 2.3. SOUND GENERATOR

The sound part consists of the sound carrier oscillator, a 1kHz-generator, an input circuitry for external sound signals and a frequency- and amplitude modulator.

**2.3.1. The 1 kHz generator** is a RC oscillator based on the Wien-bridge principle, the components of which are 860, 573 and 861, 574. A rectifier is added balancing the differential amplifier 331/1, 2, 3, 4, 5. So the stability of oscillation and amplitude is achieved.

#### 2.3.2. Sound input amplifier

For external sound signals a decoupling preamplifier 329, 331/12, 13, 14, 9, 10, 11 is available. By means of soldering link E the required pre-emphasis of 50  $\mu$ s for FM mode can be obtained. The choice of internal or external sound to be fed into the modulation circuitry is done by the electronic relay 396.

**2.3.3. The sound-oscillator and -modulator**, unit 2, fig. 26, is a Colpitts-circuitry with transistor 301/U2. By means of adjusted capacitors activated by switching diodes it is possible to select the following frequencies: 6.5 MHz, 6.0 MHz, 5.5 MHz and 5 MHz. Corresponding solder links H, J, K are to be set on unit 10.

No soldering link closed means 6.5 MHz oscillation. This frequency is adjusted by 504/U2, while the amplitude is set by 614/U2. The other sound carriers are obtained by adding capacitors parallel to the oscillator circuitry. This coupling or decoupling is done by means of the corresponding diode-switching circuitries (e.g. 402, 403, 604, 605, 606).

The sound carrier frequencies of 4.5 MHz, 5.5 MHz and 6.0 MHz are adjusted by trimmer 508, 512 and 516.

The frequency modulation of the sound carrier occurs by varicap 401, whereby the frequency sweep for 5.5 MHz is adjusted by 877/U10. The sweep of the other sound carrier frequencies depends on the capacitance ratio. Transistor 302/U2 serves as amplitude modulator.

By depressing push-buttons CARR, MOD and SOUND, the operating mode of the sound circuitry can be selected.

For Service Manuals Contact  
**MAURITRON TECHNICAL SERVICES**  
 8 Cherry Tree Rd, Chinnor  
 Oxon OX9 4QY  
**Tel:- 01844-351694 Fax:- 01844-352554**  
**Email:- enquiries@maurtron.co.uk**

## 2.4. RF PART, fig. 35

This part consists of the VHF/UHF modulator, the RF PRE-SELECTION 882, the broadband amplifier and the attenuator RF AMPL.

### 2.4.1. VHF/UHF modulator, fig. 32

The VHF/UHF modulator 895 consists of an oscillator and a modulator part in one small case. Modulator and oscillator are separated by a partition, to prevent high frequency leakage into the modulator.

The oscillator part consists of three independently adjustable oscillators, they are:

- BAND I-oscillator with transistor 302, coil 757 and tuner diode 402 (double diode)
- BAND III-oscillator with transistor 303, coil 758 and tuner diode 403
- BAND IV/V-oscillator with transistor 301, coil 756 and tuner diode 401.

The HF signal is supplied to the wide band modulator via the coupling networks 513/28 for BAND I, 516/627 for BAND III and 508/754 for BAND IV/V. In principle the wide band modulator consists of IC 351, a double balanced multiplier, the matching transformer 751 and the potentiometer 606 for adjustment of the residual carrier.

Via input 2 (IC 351) the carrier is modulated with the video signal by current drive and via input 6 (IC 351) AM-modulated with the modulated sound carrier. At the output a double-sideband signal is available.

### 2.4.2. RF pre-selector, fig. 2

The RF channel selector consists of 6 independent pre-selectable band- and channel-memories. The 6 channels are stored by using the corresponding potentiometer; the band-selection can be done by rotary switches.

## 2.5. POWER SUPPLY, unit 11, fig. 30

The power supply unit supplies four stabilized voltages: +28V for tuning the RF modulator, +12V, -12V and +5V. The +12V is adjusted by 605-607 with solder bridges X, Y, Z. The -12V supply voltage is adjusted by 608-610 with solder bridges U, V, W.

The +5V is stabilized via 354.

### 3. INSTALLATION, ACCESS TO PARTS

#### 3.1. SAFETY REGULATIONS

Upon delivery, the instrument complies with the required safety regulations. To maintain this condition and to ensure safe operation, it is recommended to follow the instructions below.

##### 3.1.1. Before connecting

###### Mains voltage

Check whether the instrument is adapted to the nominal mains voltage.

###### Protection

This instrument is protected according to class I (protective earth) of the IEC 348 or VDE 0411. The mains cable provides earth connection. Outside specially protected rooms, the mains plug must be connected only to sockets with earthed contact.

It is not allowed to interrupt the earth connection inside or outside the instrument.

##### 3.1.2. Maintenance and repair

###### Failure and excessive stress

If the instrument is suspected of being unsafe, take it out of operation permanently.

This is the case when the instrument

- shows physical damage
- does not function anymore
- is stressed beyond the tolerable limits (e. g. during storage and transportation)

###### Dismantling the instrument

When removing covers or other parts by means of tools, live parts or terminals could be exposed. Before opening the instrument, disconnect it from all power sources.

If the open live instrument needs calibration, maintenance or a repair, it must be performed only by trained personnel being aware of the risks. After disconnection from all power sources, the capacitors in the instrument may remain charged for some seconds.

###### Fuses

Only use the specified fuses.

###### Repair, Replacing parts

Repairs must be made by trained personnel. Ensure that the construction of the instrument is not altered to the detriment of safety. Above all, leakage paths, air gaps and insulation layers must not be reduced. When replacing, use only original parts. Other spare parts are only acceptable when the safety precautions for the instrument are not impaired.

#### 3.2. OPERATING POSITION

The instrument may be used in any desired position. With the handle fold down, the instrument may be used in sloping position; for this purpose press the buttons of the handle. Do not position the instrument on any surface which produces or radiates heat or in direct sunlight.

#### 3.3. EARTHING

Before switching on, the instrument must be earthed in conformity with the local safety regulations. The mains cable includes an earth lead which is connected to the earth contacts of the plug. This cable must be connected only to an earthed mains socket, to ensure proper earthing. The circuit earth potential of the generator is connected to its chassis; the external contacts of the 5 BNC sockets, contact 2 of the socket AUDIO and contact 3 of the socket VCR are also connected to the chassis. The external contacts must not be used to connect a protective conductor.

###### Warning:

Connect the mains cable plug only to a socket with protective earth contacts. This protection must not be made ineffective, e. g. by using an extension cable without earth protection!

### 3.4. ADJUSTING TO MAINS VOLTAGE

The generator must be supplied only from AC sources. On delivery, it is set to a nominal mains voltage of 220 V. It can be adapted to mains voltages of 110 V, 127 V or 240 V via the voltage switch at the rear panel. This switch can be adjusted by means of a coin; the set voltage is indicated on the switch. For secure operation of the generator, the mains voltage must not exceed  $\pm 10\%$  of the nominal value.

### 3.5. DISMANTLING THE INSTRUMENT

- Unplug the mains connector.
- Fold up the handle to the top. For this push the buttons of the handle.
- Loosen the central screw at the rear.
- Remove the lead-through of the mains cable from the cabinet.
- Dismantle the cabinet.

### 3.6. KNOBS

- Remove the cap from the knob.
- Unscrew the nut and remove the knob.
- When replacing the knob, ensure that the white mark is correctly aligned with the text plate markings.

### 3.7. TEXTPLATE

- Remove the cabinet, see 3.5.
- Remove the turn-knobs, see 3.6.
- Remove the plastic cover of the mains switch.
- The text plate can now be removed.  
Be careful:  
The textplate is fitted to the frontplate by double sided adhesive tape.

### 3.8. PUSHBUTTON UNIT

#### Replacing a pushbutton lever

The single pushbutton lever can be replaced from the front.

- Push the spring towards the pushbuttons.
- Remove the wire strap and/or lift the plastic reed between the contacts.
- Carefully tear the pushbutton lever out of the pushbutton.

#### Replacing a switch of the pushbutton unit

- Straighten the 4 retaining lugs of the relevant switches as shown in the figure below.
- Break the body of the relevant switch by means of a pair of pliers and remove the pieces. The soldering pins are then accessible.
- Remove the soldering pins and clean the holes in the printed circuit board (e. g. with a suction soldering iron).
- Bend the 4 retaining lugs back to their original positions.
- Solder the new switch on the printed circuit board.

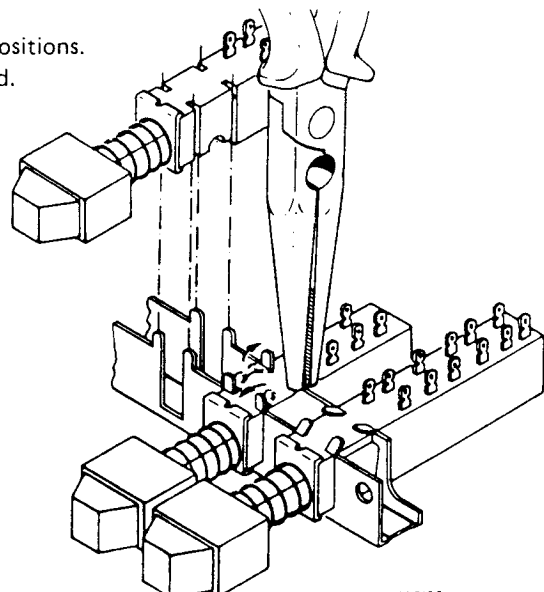

For Service Manuals Contact  
**MAURITRON TECHNICAL SERVICES**  
 8 Cherry Tree Rd, Chinnor  
 Oxon OX9 4QY  
 Tel:- 01844-351694 Fax:- 01844-352554  
 Email:- enquiries@mauritron.co.uk

## 4. CHECK AND ADJUSTMENT

## 4.1 SURVEY OF ADJUSTING ELEMENTS AND AUXILIARY EQUIPMENT

adjustment	adjusting elements	measured value	measuring instrument	example	chapter	fig.
power consumption	—	$I_{rms} \leq 85 \text{ mA}$	amperemeter	PM 2403	4.3.1	
supply voltages	X, Y, Z/U 11 U, V, W/U 11	+12.5 V $\pm$ 0.1 V -12.5 V $\pm$ 0.1 V + 5 V $\pm$ 0.15 V no influence	digital multimeter	PM 2412	4.3.2 4.3.3 4.3.4 4.3.5	31
mains fluctuations from 198 Vac to 242 Vac	—		checkerboard via oscilloscope			
	790/U 10	+28 V $\pm$ 0.5 V			4.3.6	34
hum: points A0 - A2	—	< 5 mV	oscilloscope	PM 3232	4.3.7	31
A0 - A4	—	< 10 mV				
A0 - A1	—					
A6 - A5	—					
sub-carrier frequency	503/U 1	4.433619 or 3.582056 or 3.575611 or 3.579545 } MHz $\pm$ 5 Hz	frequency counter	PM 6620	4.4.1	24
sub-carrier ampl	606/U 1	2, 6 Vpp $\pm$ 0.2 V	oscilloscope	PM 3232		
master oscillator, control voltage	513/U 1	+5.4 V ... +5.6 V	digital multimeter	PM 2403	4.4.2	25
line frequency	513/U 1	PAL: G,I,N 15625 Hz $\pm$ 2 Hz NTSC: M,MM 15734 Hz $\pm$ 2 Hz	frequency counter	PM 6620	4.4.3	25
field period time	—	PAL: G,I,N 20 $\pm$ 0.2 ms NTSC: M,MM 16.5 $\pm$ 0.2 ms	counter		4.4.4	21
line pulse, blank front porch	—	11,9 $\pm$ 0.2 $\mu$ s 1.45 $\pm$ 0.15 $\mu$ s	oscilloscope	PM 3232	4.4.5	21
line sync pulse	—	4.75 $\pm$ 0.2 $\mu$ s				
line- and burst pulse- distance	—	0.85 $\pm$ 0 $\mu$ s				
colour sync. pulse	—	2,3 $\pm$ 0.2 $\mu$ s				
RRP pulse distance width	—	3.3 $\pm$ 0.2 $\mu$ s 0.53 $\pm$ 0.05 $\mu$ s			4.4.7	
field pulse comp. sync. signal	—	160 $\pm$ 3 $\mu$ s or 158.9 $\pm$ 3 $\mu$ s	oscilloscope (delayed time base)	PM 3250	4.4.6	
field blank	—	1.6 $\pm$ 0.1 ms				
trigg. amplitude line and field	—	> 3,5 V > 3,5 V			4.4.8	21
video polarity	714/U 10	p-p level, see fig. 4.5.1	oscilloscope	PM 3232	4.5.1	fig. in 4.5.1
— ampl. via OUT	747/U 10	2 Vpp $\pm$ 0.06 V			4.5.2	for white patt.
— via VCR OUT, pin 2	—	2 Vpp $\pm$ 0.06 V				23
— sync. pulse ampl.	—	600 mVpp				
BL/WH pattern signals - circle	664/U 10 671/U 10 657/-, 748/ U 10	optically circular circle diameter eccentricity, ellipticity	oscilloscope TV receiver	PM 3232	4.7.1	
- checkerboard	—	2 $\pm$ 0.1 V			4.7.2	4.7.2
- dots	—	2 $\pm$ 0.1 V				29
- crosshatsch	—	2 $\pm$ 0.1 V				
- greyscale and definition lines	624/U 3 606/U 3	2 $\pm$ 0.1 V 1st bar: 1.25 $\pm$ 0.05 $\mu$ s 5th bar: 0.208 $\pm$ 0.006 $\mu$ s			4.7.3	4.7.3
- VCR ampl. period time	631/U 3	1.9 $\pm$ 0.1 Vpp 1st fr. group: 0,3 to 0,32 $\mu$ s 2nd fr. group: 0,322 to 0,344 $\mu$ s 3rd fr. group: 0,349 to 0,371 $\mu$ s			4.7.4	29

adjustment	adjusting elements	measured value	measuring instrument	example	chapter	fig.
chroma amplitude	823/U10	4th bar upper level to 75% white	oscilloscope	PM 3232	4.8.1.1	
fixed chroma ampl./%	635/U 10	0-25-50-75-±5 %	oscilloscope	PM 3232	4.8.1.2	
colour modulator - symmetry	800, 809/U 10 811/U 10	colour carrier to minimum only for rough adjustment	oscilloscope and	PM 3232	4.8.2	34
colour pattern signals - white ampl. - monochrome	747/U 10	1±0.05 V with 75-Ω-load-resistor vectorscope figures	termination vectorscope (75 Ω)	PM 9586 1421 (Tektronix)	4.9	4.9.
- bar - DEM - VCR	811/U 10	burst phase 90° ±1				4.9.1 } 4.9.2
sound check - 1 kHz generator, intern - carrier frequency - carrier ampl.	504 or 508 or 512 or 516/U 2 614/U 2	1±0.1 Vrms to VCR conn. pin 4; 1 kHz, at load of 10 kΩ see. table 1.1. 400 ±5 mVrms to TP 12	oscilloscope  counter or selektive voltmeter or	PM 3232  PM 6620 or (Bruell & Kjaer 2007)	4.11.1	4.11.1  table 1.1
ampl.: RF/sound carr.	614/U 2	-12.5 ±0.5 dB at a freq. of e.g. 200 MHz to RF OUT			4.11.3	27
sound external: 1 kHz 0.2 Vrms, sine wave	877/U 10	40 ±3 KHz, Δt at TP12 *	modulation meter (FM)		4.11.2	34
RF check	VHF-modulator 627 628	4-18 mV, ampl. alternation for range 170 - 250 MHz for range 38 - 90 MHz	counter sampling voltmeter	PM 6620 e.g. WISI WA 01	4.6.1	32
residual RF carrier	UHF/VHF modulator 606	10 - 15 % to RF OUT ** (UHF 40 %)	oscilloscope  sampl. voltmeter	PM 3240  e.g. WISI WA 01	4.6.2	
external video signal (of 1 Vpp/75 Ω) to VIDEO IN		check (samples only) according to 4.7, 4.8, 4.9          - 13 - 1 dB at freq. * of e. g. 200 MHz to RF OUT   series LO 17 . . . onwards: 10 % - 12 % at 200 MHz ** check modul. compression at ca. 623 MHz < 30 % in total range	video generator       spectrum analyzer CTV spectrum analyzer	PM 5509 or PM 5519	4.10.	         see SGS 47       see SGS 47

For Service Manuals Contact  
**MAURITRON TECHNICAL SERVICES**  
8 Cherry Tree Rd, Chinnor  
Oxon OX9 4QY  
Tel:- 01844-351694 Fax:- 01844-352554  
Email:- enquiries@mauritron.co.uk

## 4.2. GENERAL

### 4.2.1. Pushbuttons

In this chapter only the indicated pushbuttons are to be pressed; all others remain unlocked.

### 4.2.2. Tolerances

Tolerances given in this chapter apply for newly adjusted instruments and may differ from those given in chapter 1.2. "TECHNICAL DATA".

### 4.2.3. Positioning

For positioning of the elements see figs.

### 4.2.4. Warming-up

The instrument may only be adjusted after a warm-up time of at least 30 minutes.

## 4.3. POWER SUPPLY

### 4.3.1. Power consumption

- Adjust the instrument to a mains voltage of 220 V ~by means of a variable transformer.
- Measure the current consumption:  $I_{rms} < 85 \text{ mA}$ .

### 4.3.2. Adjustment to +12.5 V

- Connect a digital multimeter to test point 1 (TP 1), pin A 2/U 11.
- Check the voltage for  $+12.5 \text{ V} \pm 0.1 \text{ V}$ . If necessary, readjust with solder bridges X, Y, Z/U 11.

### 4.3.3. Adjustment to -12.5 V

- Connect a digital multimeter to TP 2, A 4/U 11.
- Check the voltage for  $-12.5 \text{ V} \pm 0.1 \text{ V}$ . If necessary, readjust with solder bridges U, V, W/U 11.

### 4.3.4. Adjustment to +5 V

- Connect a digital multimeter to TP 3, A 5/U 11.
- Check that the voltage is  $+5 \text{ V} \pm 0.15 \text{ V}$ .

### 4.3.5. Checking the stabilisation due to mains fluctuations

- Change the mains voltage from 198 V to 242 V a. c.
- Check that there is no influence to the above mentioned voltages.

### 4.3.6. Adjustment to +28 V

- Connect a digital multimeter to TP 4, 15/U 10 .
- Check that the voltage is  $+28 \text{ V} \pm 0.5 \text{ V}$ .
- If necessary, readjust with 790/U 10.

### 4.3.7. Checking hum voltages, unit 11

- Connect an oscilloscope successively to points A 0 and A 2; A 0 and A 4; A 0 and A 1; A 6 and A 5.
- Check that the hum voltages between points
  - A 0 – A 2 is  $< 5 \text{ mV}$
  - A 0 – A 4 is  $< 5 \text{ mV}$
  - A 0 – A 1 is  $< 10 \text{ mV}$
  - A 6 – A 5 is  $< 10 \text{ mV}$

#### 4.4. MODULATION- AND SYNCHRONISATION-FREQUENCY AND PULSES

##### 4.4.1. Sub-carrier frequency

- Connect a frequency counter to test point 5 (TP 5), pin 11/U 1.

- Check the sub-carrier frequency:

PAL G, I:	4.433619 MHz	} ±5 Hz
PAL N:	3.582056 MHz	
PAL M:	3.575611 MHz	
NTSC (MM):	3.579545 MHz	

If necessary, readjust with capacitor 503/U 1.

**Sub-carrier amplitude**, see also SGS 47

- Connect oscilloscope with 10 : 1 probe to TP 5 , pin 11/U 1.
- Check the sub-carrier amplitude : 2.6 V<sub>pp</sub> ±0.2 V.
- If necessary readjust with 606/U 1; R max < 470 Ω.

##### 4.4.2. Master oscillator, control voltage

- Connect a digital multimeter to TP 6, 17/U 1.
- Check that the voltage is between +5.4 and 5.6 V. If necessary readjust with capacitor 513/U 1.
- Check duty cycle at pin 16/U1 to 0.45 ... 0.55 (if necessary, correct by alter resistor 612/U1 to 64.9 K ... 121 K and capacitor 510/U1 to 22N).

##### 4.4.3. Line frequency

- Connect a frequency counter to TP 7, pin 11, integrated circuit 351/U 10.
- Check the line frequency:
 

PAL G, I, N:	15625 Hz ±2 Hz
NTSC, PAL M:	15734 Hz ±2 Hz

##### 4.4.4. Field frequency

- Connect a frequency counter to TRIGGER FRAME.
- Check the period time:
 

20 ±0.2 ms	for line frequency 15625 Hz
16.7 ±0.2 ms	for line frequency 16734 Hz

##### 4.4.5. Line pulses

- Connect oscilloscope to connector VIDEO OUT.
- Push buttons WHITE and CHROMA AMPL 0 %; without Burst.
- Push buttons WHITE and CHROMA AMPL 100 %; with Burst.
- Check line pulses according to the figure.

The indicated times should be:

A	11.9 ±0.2 μs
B	1.45 ±0.15 μs
C	4.75 ±0.2 μs
D	0.85 ±0.3 μs
E	2.3 ±0.2 μs

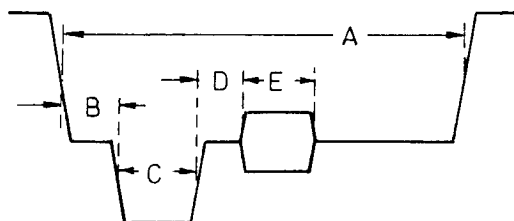

For Service Manuals Contact  
**MAURITRON TECHNICAL SERVICES**  
 8 Cherry Tree Rd, Chinnor  
 Oxon OX9 4QY  
 Tel:- 01844-351694 Fax:- 01844-352554  
 Email:- enquiries@mauritron.co.uk



#### 4.4.6. Frame pulses, composite sync signal

- Connect oscilloscope to connector TRIGGER COMP SYNC.
- Check the comp sync pulses according to the figure.

The indicated times should be:

- A             $160 \pm 3 \mu s$  or  $158.89 \pm 3 \mu s$   
 B             $320 \pm 6 \mu s$   
 C             $1.6 \pm 0.1 ms$  ( field blanking )

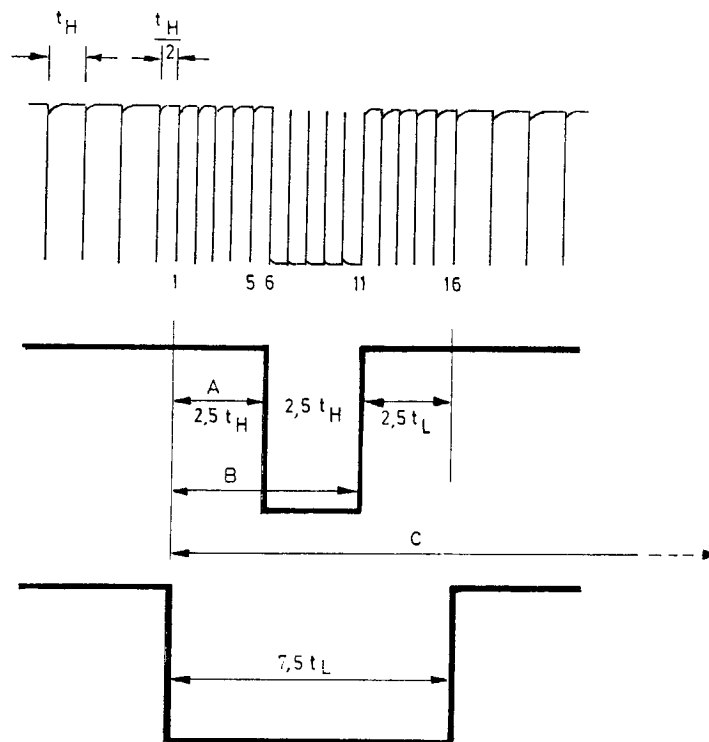

#### 4.4.7. RRP pulses

- Push buttons WHITE, CHROMA AMPL 0 % and RRP.
- Check the RRP pulse according to the figure.

The indicated time should be:

- A             $3.3 \pm 0.2 \mu s$   
 B             $0.53 \pm 0.05 \mu s$

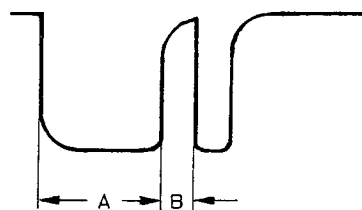

- Unlock button RRP.
- The RRP pulse must disappear.

#### 4.4.8. Trigger amplitude

- Connect oscilloscope to TRIGGER COMP SYNC.
- Check the pulse for  $> 3.5 V$ .
- Connect oscilloscope to TRIGGER FRAME.
- Check the pulse for  $> 3.5 V$

- 4.4.9. When replacing the OQ 5501 check and if necessary change the polarity of the clock pulse (instable checkerboard); see also Fig. 7.

## 4.5. VIDEO SIGNALS

### 4.5.1. Video polarity

- Connect an oscilloscope, channel A to TP 8, pin 7/314/U 10, channel B to TP 9, pin 8/314/U 10.
- Push buttons WHITE and CHROMA AMPL 0 %.
- Compare amplitude and level of the complementary video signals.
- If necessary readjust with 714/U 10.

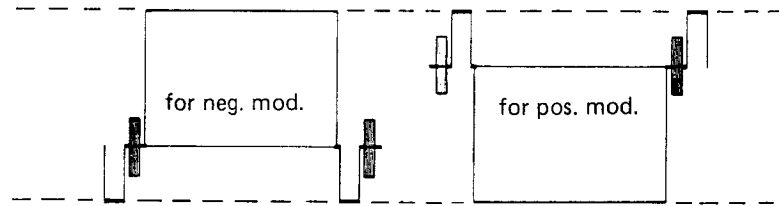

### 4.5.2. Video amplitude

- Connect oscilloscope to VIDEO OUT.
- Lock potentiometer VIDEO AMPL to 1 V.
- Push buttons WHITE and CHROMA AMPL/0 %.
- Check amplitude for 2 Vpp  $\pm$ 0.06 V, synchron pulse amplitude for 600 mVpp. If necessary adjust with resistor 747/U 10 in parallel to resistor 739/U 10.
- Turn potentiometer VIDEO AMPL to 0 V.
- Check video amplitude for <20 m Vpp.
- Turn potentiometer VIDEO AMPL to maximum.
- Check video amplitude for 2.9 ... 3.1 Vpp.
- Lock potentiometer VIDEO AMPL to 1 V.
- Connect oscilloscope to VCR out, pin 2
- Check amplitude for 2 Vpp  $\pm$ 0,06 V

For Service Manuals Contact  
**MAURITRON TECHNICAL SERVICES**  
 8 Cherry Tree Rd, Chinnor  
 Oxon OX9 4QY  
 Tel:- 01844-351694 Fax:- 01844-352554  
 Email:- enquiries@mauritron.co.uk

## 4.6. RF-CHECK

### 4.6.1. RF-frequency range and amplitude

- Connect frequency counter and a sampling voltmeter (e. g. WISI) via BNC-T-connector to RF OUT.
- Push button CHECKERBOARD.
- Unlock buttons VIDEO INT/EXT and SOUND CARR ON/OFF.
- Turn RF AMPL to maximum.
- Check RF frequency and amplitude within the indicated bands for attaining the indicated limits according to the following table.

tip-touch buttons	bands*	range	amplitude tolerance range	adjustment with
1	I	38 – 90 MHz	} 4 – 18 mV	} 628**
2	I	38 – 90 MHz		
3	III	170 – 250 MHz		} 627**
4	III	170 – 250 MHz		
5	IV/V	470 – 820 MHz		
6	IV/V	470 – 820 MHz		

\* The bands are adjusted by means of the rotary buttons near the tip-touch buttons of the RF PRE-SELECTION unit. For this purpose press and turn the required rotary button (see chapter 2.1.4. of the operating manual).

\*\* Select-in-test (amplitude band I and band III), positioned in the VHF/UHF modulator 895/U 10.

#### 4.6.2. Residual RF carrier , see also SGS 47

- Channel 1 may be switched on.
- Connect oscilloscope ( $f > 12$  MHz) to RF OUT.
- Push button CHECKERBOARD.
- Adjust the residual carrier to 10 – 15 % with 606 of the VHF/UHF modulator.

#### 4.7. BL/WH PATTERNS AND SIGNALS

- Connect oscilloscope to VIDEO OUT.
- Connect TV receiver to RF OUT.
- Push buttons CHROMA AMPL 0 % and CHROSSHATCH.

##### 4.7.1. Circle

Push buttons:



DOTS



CIRCLE

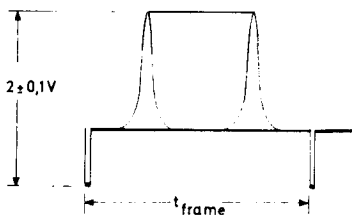
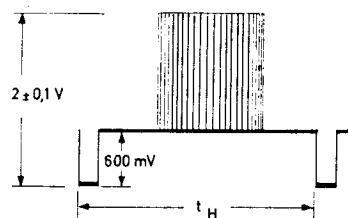

- The circle must be "optically circular".
- The circle must be positioned within 9 horizontal distances of the dots.
- Maximum permitted eccentricity of the circle:  
2 x diam. of a dot.
- Corrections can be attained by 664/U 10, 671/U 10.
- Correction of the vertical ellipticity is possible with 657/U 10.
- Check the circle for being combinable with all test patterns.

#### 4.7.2. Standardized digital signals



CHECKERBOARD

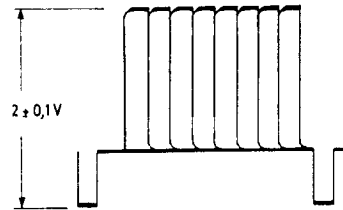

DOTS

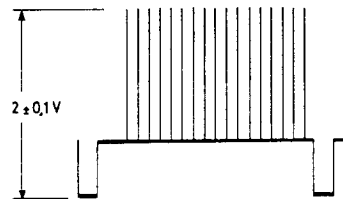

CROSSHATCH

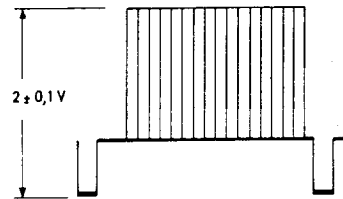

#### 4.7.3. GREYSCALE and DEFINITION LINES



- Push buttons CHROMA AMPL 0 % and
- Connect oscilloscope with 10 : 1 probe to TP 10, 6/U 3.
- Check the period time of the burst in the group of frequencies in the 1st and 5th bar.
 

1st bar:	$1.25 \pm 0.05 \mu s$ , adjustable with 624/U 3
5th bar:	$0.208 \pm 0.006 \mu s$ , adjustable with 606/U 3

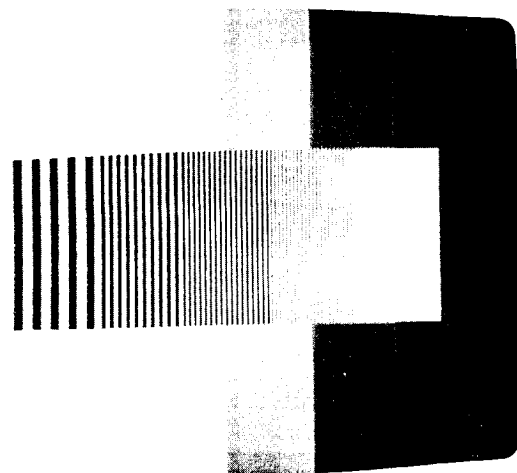
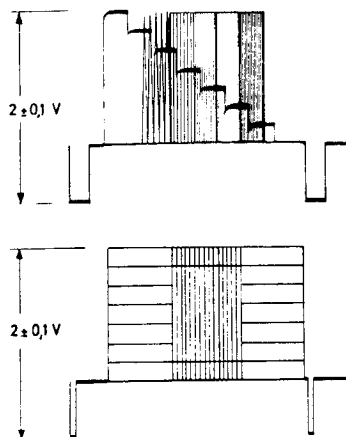

#### 4.7.4. VCR

- Push button VCR
- Check the period times: 1st frequency group  $0.300$  to  $0.320 \mu s$ , 2nd frequency group  $0.322$  to  $0.344 \mu s$ , 3rd frequency group  $0.349$  to  $0.371 \mu s$
- Check the amplitude for  $1.9 \pm 0.1 V_{pp}$ . If necessary adjust with 631/U 3, not exceeding the white level in the video signal.

## 4.8. COLOUR SIGNALS

### 4.8.1. Chroma amplitude

#### 4.8.1.1 Adjusting the 4th bar of the BAR-pattern

- Oscilloscope to connector VIDEO OUT
- Oscilloscope to trigger mode LINE
- Depress button BAR
- The 4th bar should have an amplitude which is the same as the amplitude of 75 % white. Adjustment with potentiometer 823/U 10, so that  $B = A \pm 0.03 \text{ V}$ . VIDEO OUTPUT must be terminated with  $75 \Omega$ .
- The 3rd bar should be on black level.

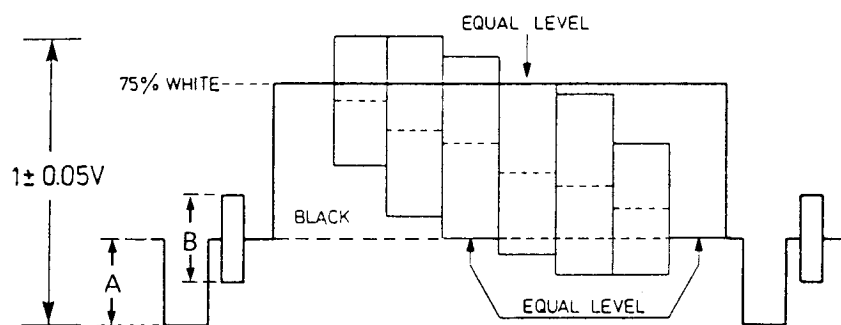

#### 4.8.1.2 Fixed CHROMA AMPLITUDE/%

- Connect oscilloscope with 10 : 1 probe to TP 11, 693/530/U 10.
- Pushbuttons BAR and CHROMA AMPL 100 %.
- Check signals according to the figure; the amplitude (pp) is 100 %.
- Unlock button CHROMA AMPL 100 %; amplitude (pp) is 120 %  $\pm 10$  %.
- Pushbuttons

CHROMA AMPL/..	Effective chroma ampli.	Adjustment, check
50 % and 100 %	75 % $\pm 5$ %	
50 %	50 % $\pm 5$ %	635/U 10
50 % and 0 %	25 % $\pm 5$ %	
0 %	0 % $\pm 5$ %	no colour on connected C.T.V.

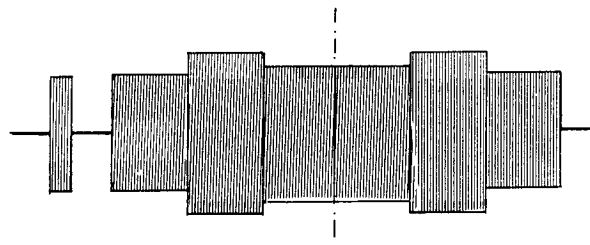



#### 4.8.2. Residual colour carrier and symmetry of the colour modulator

- Check the residual colour carrier for being minimum. If necessary adjust with 800/U 10 and 809/U 10.
- Adjust signal symmetry with 811/U 10 (only for rough adjustment).
- Pushbutton DEM, control the residual colour carrier and adjust to minimum.

4.9. COLOUR PATTERN SIGNALS for PAL and NTSC

- Pushbutton CHROMA AMPL 100%.
- Lock potentiometer VIDEO AMPL to 1V.
- Connect oscilloscope and vectorscope to VIDEO OUT (75 Ω input impedance for vectorscope)
- Pushbutton

Indicated tolerances on the vectorscope:  
 field of tolerance for adjustment  
 extended field of tolerance.

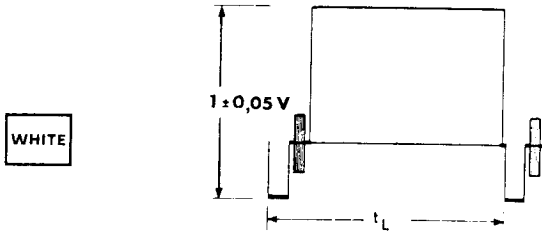

- Burst must be present.
- Check the colour video amplitude (pp) for  $1V \pm 0.05V$ .
- If necessary repeat 4.8.2.
- Check video signal range for 0 to  $\geq 1.5V_{pp}$  with potentiometer VIDEO AMPL.

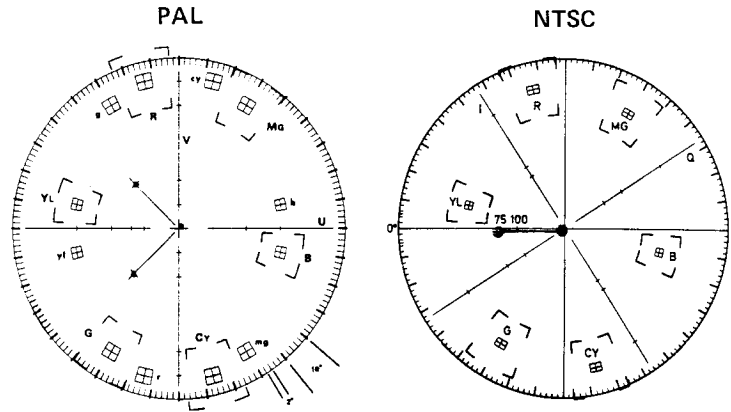

4.9.1. Monochrome patterns

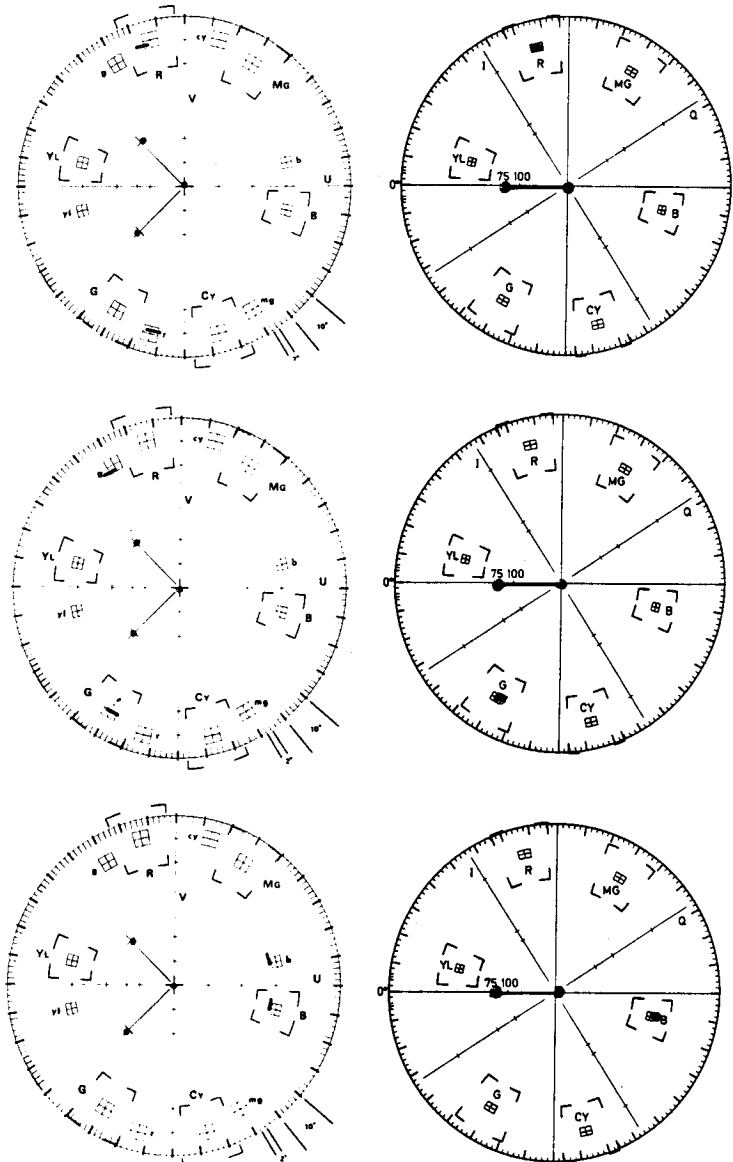
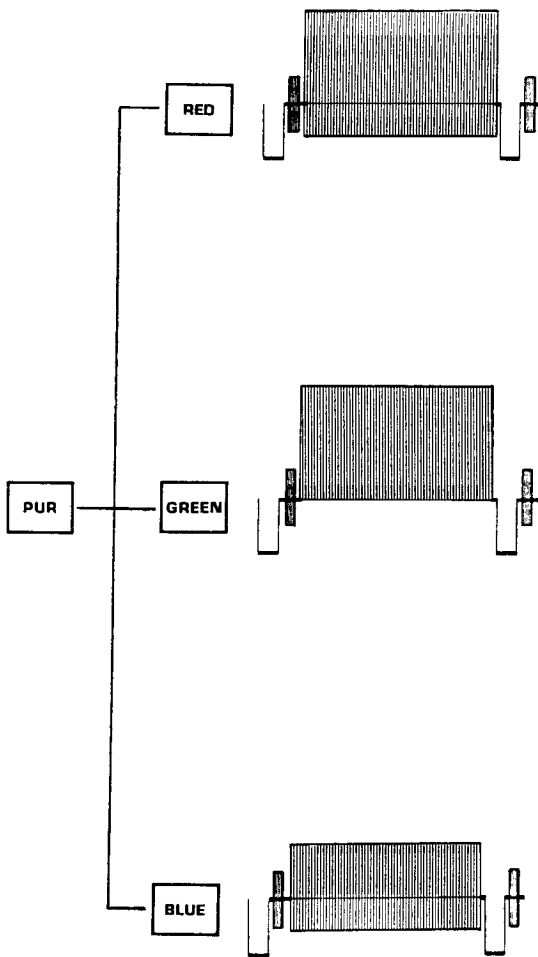

4.9.2. Combined colour patterns

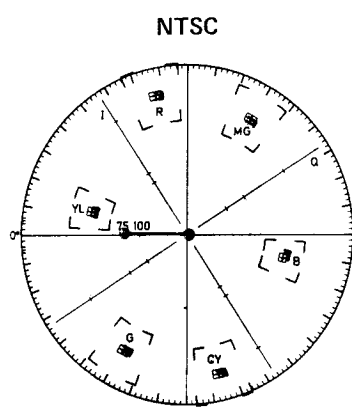
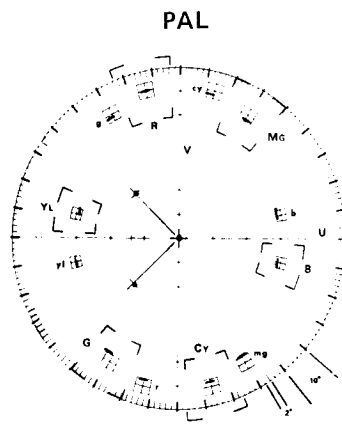
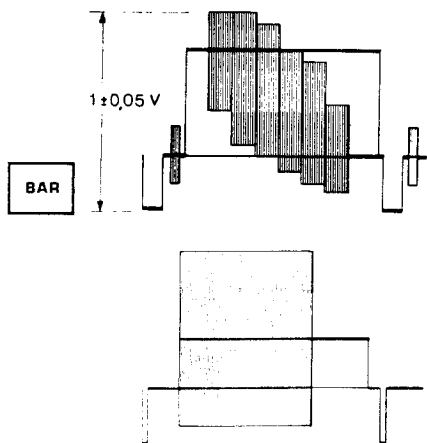

- shifting interference at the transitions of the patterns must have equal velocity

Burst phase:  $90^\circ \pm 1^\circ$   
adjustment with 811/U10

Burst amplitude: 75 %  
adjustment with 811/U 10

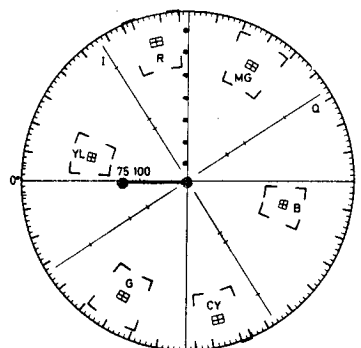
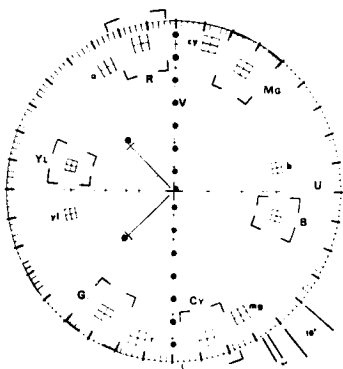
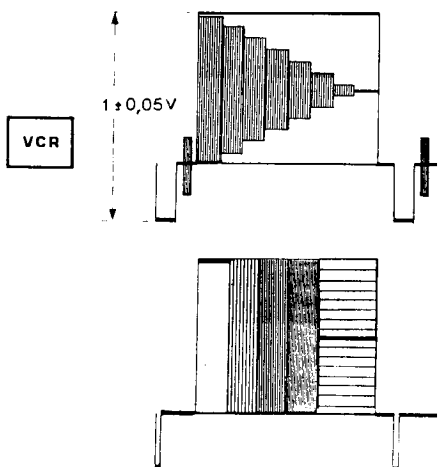
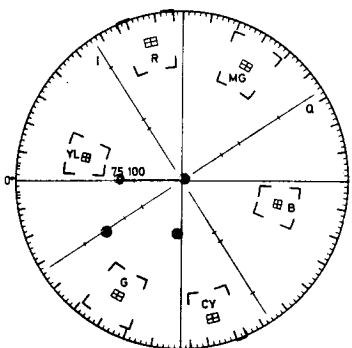
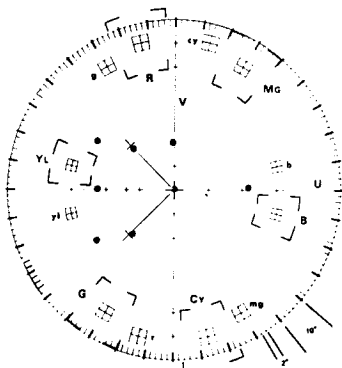
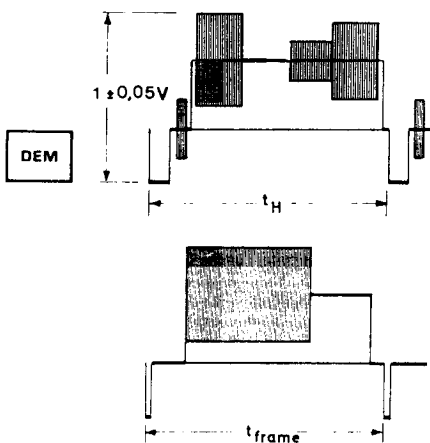

4.10. **EXTERNAL VIDEO**

- Push button VIDEO INT/EXT.
- Feed external video signal of 1 Vpp/75 Ω into connection VIDEO IN.
- Check external video signal according to 4.8. and 4.9.

4.11. **SOUND CHECK**

4.11.1. **Sound internal**

- Unlock all sound buttons.
- Connect oscilloscope to connection VCR, pin 4 (rear side).
- Check the 1 kHz sinewave signal for  $1 \pm 0.1$  Vrms at a load of 10 kΩ.
- Connect selective voltmeter or frequency counter to TP 12, pin 6/U 2.
- Select the desired sound carrier frequency by soldering the relevant joints, see table.
- Depress button MOD.
- Check the carrier frequency. If necessary adjust with 504 or 508 or 512 or 516 of U 2, see table 1.1.
- Check the amplitude for  $400 \pm 5$  Vrms. If necessary adjust with 614/U 2.
- Unlock button MOD.

4.11.2. **Sound external**

- Push button SOUND 1 kHz/EXT.
- Feed external sinewave 1 kHz/0.2 Vrms (0.566 Vpp) to connection AUDIO, pin 3 (rear side).
- Connect modulation meter to 6/U 2 for deviation check.
- The deviation must be 40 kHz  $\pm 3$  kHz; adjustment with 877/U 2.

4.11.3. **Amplitude RF/sound-carrier**, see also SGS 47

- Push button CHECKERBOARD and SOUND MOD CARR ON/OFF.
- Turn RF AMPL to maximum.
- Connect a selective voltmeter (e. g. Bruell & Kjaer 2007) to RF OUT and check that the amplitude ratio of the video to the sound carrier is 12.5 dB at a frequency of e. g. 200 MHz (video carrier ampl/video carrier + sound carrier ampl. =  $12.5 \pm 0.5$  dB). If necessary adjust with 614/U 2.

Table 1.1.

Sound carrier	Solder bridge	H	J	K	F	G	Adjusting element	Meas. value to pin 6/U2	
PAL { I : 6 MHz G : 5.5 MHz M, N : 4.5 MHz NTSC M (MM): 4.5 MHz	} $\pm 10$ kHz	○	●	○			504/U2	} $400 \pm 5$ mV(rms)	614/U2
		○	●	○			508/U2		
		●	○	○			512/U2		
		●	○	●			516/U2		
		●	○	●			516/U2		
FM					●	○	877/U10	$40 \pm 3$ kHz	$\Delta f$
AM					○	●			
Sound ext. With preemphasis									●
Without preemphasis									○

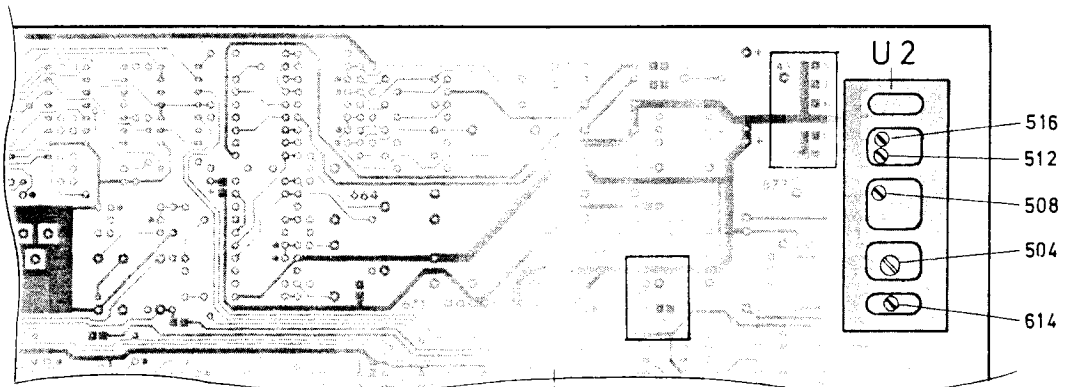

○ solder bridge open  
 ● solder bridge closed



## 5. MODIFICATION INTO VARIOUS VERSIONS

## 5.1. PERFORMANCE DETAILS OF VARIOUS VERSIONS

For changing PM 5519 to the version I, N, M, MM (NTSC), see chapter 1.2.2.

For special requirements and for some countries, there are extended versions of CTV Pattern Generator PM 5519 on the market. There does not exist any conversion kit to change to these versions. More detailed information is given by the following "Service Information" sheets:

PM 5519GS	cable TV	}	SGS 20	9499	528	03011
	(S-channels)		SGS 25	9499	528	03202
PM 5519GX	stereo/two channel		SGS 30	9499	528	03411
PM 5519D	China/Korea		SGS 31	9499	528	03511

## 5.2. PM 5519G into PM 5519I

Unit 10:

- Close solder joint I
- Open solder joint H
- Check and, if necessary, correct vision to sound distance according to chapter 4.11.1. and chapter 4.11.3., table 1.1.

Add suffix "I" to the type plate at the rear side.

## 5.3. PM 5519G into PM 5519N

Unit 10:

- Close solder joint K
- Replace capacitor 580 (47 nF) by capacitor of 68 nF
- Replace resistor 838 (316 Ohm) by resistor of 442 Ohm
- Replace resistor 840 (357 Ohm) by resistor of 442 Ohm
- Replace resistor 613/U2 (38,3K) by a resistor of 26,1 kOhm.
- Check and, if necessary, correct vision to sound distance according to chapter 4.11.1. and chapter 4.11.3., table 1.1.

Unit 1:

- Close solder joint O
- Replace X-tal pos. 751 by X-tal of 3.582056 MHz
- If amplitude of colour carrier is not sinusoidal or is higher than prescribed:  
Replace capacitor 507 (33 pF) by capacitor of 100 pF.
- Check adjustment according to 4.4.1.; if necessary, correct 4.4.2., 4.8.2. and 4.9.

Add suffix "N" to type plate at the rear side.

## 5.4. PM 5519G into PM 5519M

Unit 10:

- Close solder joint K
- Replace capacitor 580 (47 nF) by capacitor of 68 nF
- Replace resistor 660 (237 kOhm) by resistor of 301 kOhm
- Replace resistor 838 (316 Ohm) by resistor of 442 Ohm
- Replace resistor 840 (357 Ohm) by resistor of 442 Ohm
- Check and, if necessary, correct vision to sound distance according to chapter 4.11.1. and chapter 4.11.3., table 1.1.

## Unit 1:

- Close solder joint M
- Open solder joint N
- Replace X-tal 751 by X-tal of 3.575611 MHz
- If amplitude of colour carrier is not sinusoidal or is higher than prescribed:  
 Replace capacitor 507 (33 pF) by capacitor of 100 pF.
- Check adjustment according to 4.4.1; if necessary, correct 4.4.2., 4.8.2. and 4.9.

Add suffix "M" to type plate at the rear.

## 5.5. PM 5519G into PM 5519MM (NTSC)

## Unit 10:

- Close solder joint K
- Replace capacitor 580 ( 47 nF) by capacitor of 68 nF
- Replace resistor 660 (237 kOhm by resistor of 301 kOhm
- Replace resistor 798 (11.5 kOhm) by resistor of 6.81 kOhm
- Replace resistor 838 (316 kOhm ) by resistor of 442 Ohm
- Replace resistor 840 (357 Ohm) by resistor of 442 Ohm
- Isolate pin 6 of OQ5502 pos.352 and ground pin 6 separately. (Cut pin 6 from the pcb and connect pin 6 of the integrated circuit directly to pin 7/8 of OQ5502).
- Check and, if necessary, correct vision to sound distance according to chapter 4.11.1. and chapter 4.11.3., table 1.1.

## Unit 1:

- Close solder joints O, Q, M
- Open solder joints P, N
- Replace X-tal 751 by X-tal of 3.579545 MHz
- If amplitude of colour carrier is not sinusoidal or is higher than prescribed:  
 Replace capacitor 507 (33 pF) by capacitor of 100 pF.
- Check adjustment according to 4.4.1.; if necessary, correct 4.4.2., 4.8.2. and 4.9.

Replace mains cable by the standard American mains cable.

Add suffix "MM" to the type plate at the rear side.

## 5.6. ORDERING NUMBERS FOR THE PARTS MENTIONED ABOVE:

unit	pos.	ordering number	value	tol.%	item
10	580	5322 121 44137	68 nF	10	polyester foil
10	660	5322 116 54743	301 kOhm	1	metal film
10	838	5322 116 50592	442 Ohm	1	metal film
10	840	5322 116 50592	442 Ohm	1	metal film
10	798	5322 116 54012	6.81 kOhm	1	metal film
2	613	5322 116 54651	26.1 kOhm	1	metal film
1	507	4822 122 31081	100 pF	2	ceramic plate
1	751	4822 242 70323	4.433619 MHz		X-tal (G,I)
1	751	5322 242 70437	3.582056 MHz		X-tal (N)
1	751	5322 242 74083	3.575611 MHz		X-tal (M)
1	751	4822 242 70105	3.579545 MHz		X-tal (MM)
		5322 321 14021			stand. American
					mains cable
		5322 401 14038			mains cable
					cleat

## 6. P A R T S L I S T P M 5 5 1 9

## 6.1. MECHANICAL PARTS, MISCELLANEOUS

Item	Quantity	Order number	Description	
1	1	5322 447 94324	Cover, grey	
1	1	5322 447 90395	Cover, brown	
2	4	5322 462 44174	Foot (bottom side), grey	
2	4	5322 462 10222	Foot (bottom side), brown	
3	2	5322 520 34164	Bearing bush	
4	2	5322 530 84075	Spring	
5	2	5322 528 34101	Ratchet	
6	2	5322 532 54425	Ring for handle, grey	
6	2	5322 532 51481	Ring for handle, brown	
7	2	5322 498 54048	Arm of handle	
8	1	5322 498 54051	Carrying handle	
9	2	5322 414 64053	Knob, grey	
9	2	5322 414 30043	Knob, brown	
10,	1	5322 447 94188	Back frame	
12	4	5322 462 44176	Foot (rear side)	
13	1	5322 502 24525	Coin-slot screw	
14	1	4822 530 70124	Locking washer for pos.13	
15	2	5322 414 74014	Cover for knobs, grey	
15	2	5322 414 70017	Cover for knobs, brown	
16	1	5322 455 74084	Textplate, grey	
17	1	5322 459 24076	Front frame	
18	1	5322 447 94363	Contact protection cap	*S
19	4	5322 462 34115	Print holder	
20	1	5322 414 34083	Control knob, grey	
20	1	5322 414 30069	Control knob, brown	
21	1	5322 414 34082	Control knob, grey	
21	1	5322 414 30039	Control knob, brown	
22	21	5322 414 25851	Knob for pushbutton, grey	
22	21	5322 414 20033	Knob for pushbutton, brown	
23	5	5322 267 10004	BNC Connector (pos.295-299)	
24	1	5322 276 14128	Mains switch (pos.881)	*S
25	1	5322 218 64095	Memostat (pos.882)	
25a	6	5322 414 30027	Knob small for memostat	
26	6	5322 276 84068	Switch/U10 (pos.885/1,11-15)	
27	9	5322 276 84069	Switch/U10 (pos.885/2-10)	
28	2	5322 276 34058	Switch (pos.886,887)	
29	1	4822 267 40045	DIN Connector 6 pol. (pos.883)	
30	1	4822 267 40039	DIN Connector 5 pol. (pos.884)	
31	1	5322 272 10215	Mains selector (pos.885)	*S
32	2	4822 266 30073	6 pol. socket	
33	2	4822 265 30117	6 pol. plug (U11)	
34	2	5322 255 44129	Heat sink (U11)	
35	1	5322 325 60119	Pull relief	*S
36	1	5322 290 30192	Soldering terminal	*S
37	1	5322 325 64068	Grommet for cover	*S
38	1	5322 321 14048	Mains cable 1850	*S
39	1	5322 401 14275	Mains cable clamp	*S
40	1	5322 212 84113	Unit 1 compl.	

\*S = safety component

Item	Quantity	Order number	Description
41	1	5322 212 84115	Unit 2 compl
42	1	5322 212 84116	Unit 3 compl.
43	1	5322 212 84114	Unit 11 compl.
44	1	5322 218 64054	VHF-UHF-Modulator
45	1	5322 101 44084	Potentiometer 10 kOhm
46	1	5322 105 40007	RF-Potentiometer 75 Ohm (pos.594)
47	1	5322 116 54608	7.5 kOhm/1% (pos.748)
48	1	5322 116 54592	4.02 kOhm/1% (pos.750)
49	1	5322 146 20675	Mains transformer (pos.785) *S
50	4	5322 280 24047	Relais/U10 (pos.891-894)
51	1	5322 121 44028	Capacit. XY 10N 2x2.5N (pos.595)*S
52	-	5322 390 20019	Silicon paste DC 340
53	1	5322 116 54188	1MOhm 1 % (pos. 600)
54	1	5322 252 20092	Therm.fuse (switch) > series/07 *S

Sept. 1984

\*S = safety component

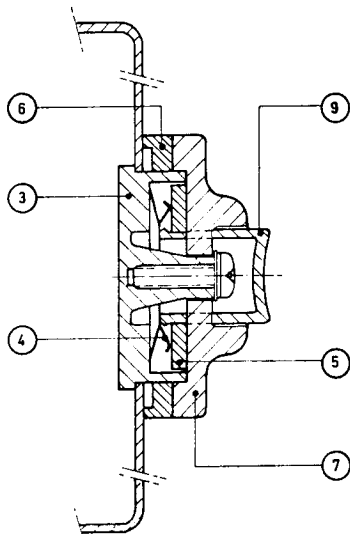
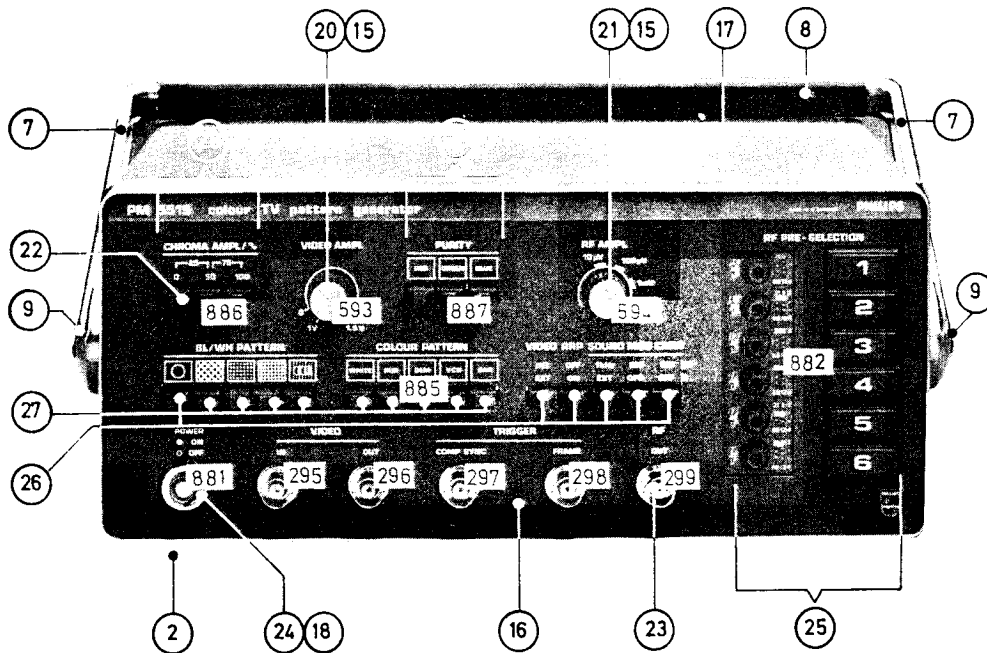

Fig. 21 Front view: spare parts

For Service Manuals Contact  
**MAURITRON TECHNICAL SERVICES**  
 8 Cherry Tree Rd, Chinnor  
 Oxon OX9 4QY  
 Tel: 01844-351694 Fax: 01844-352554  
 Email: enquiries@mauritron.co.uk

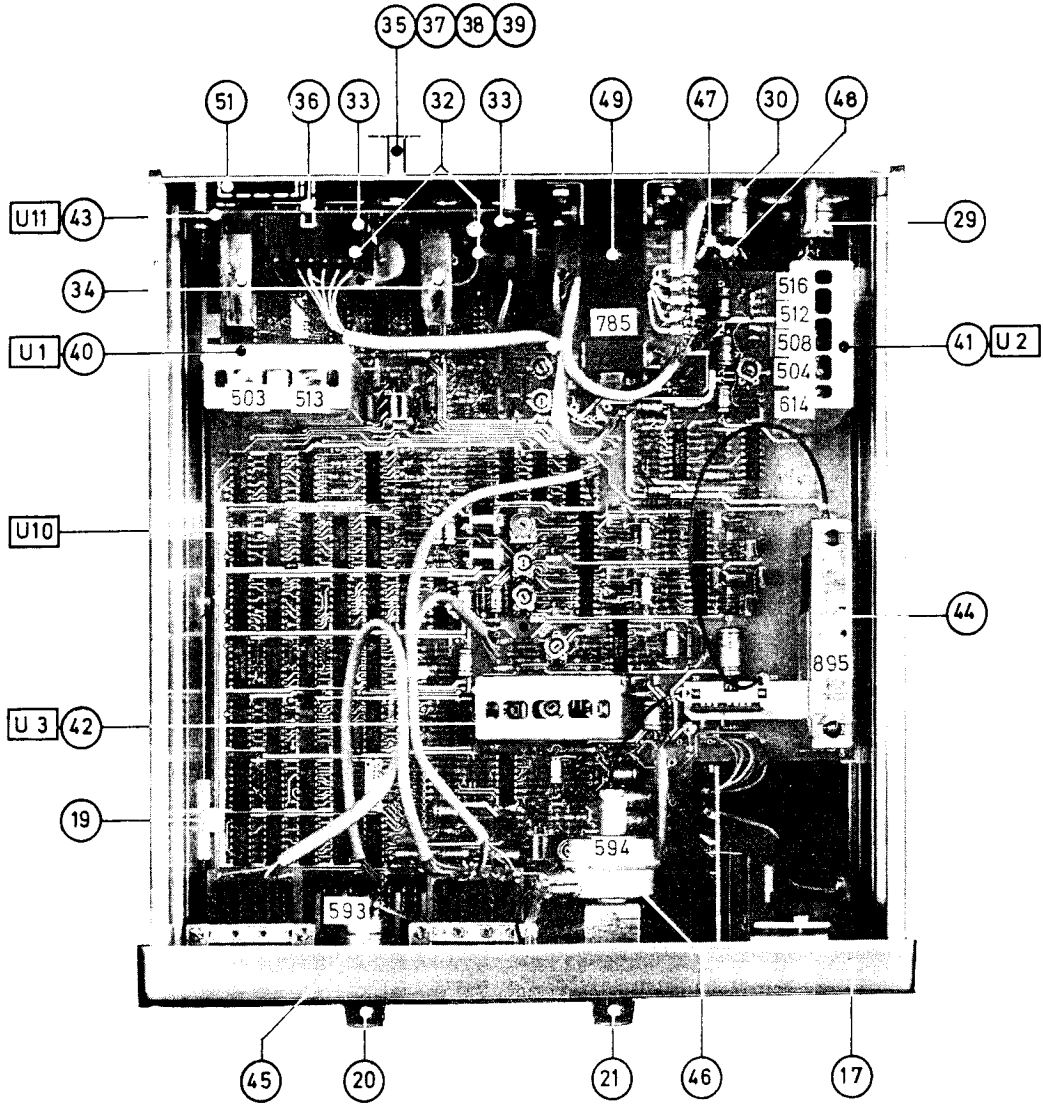

Fig. 22 Inside view: spare parts

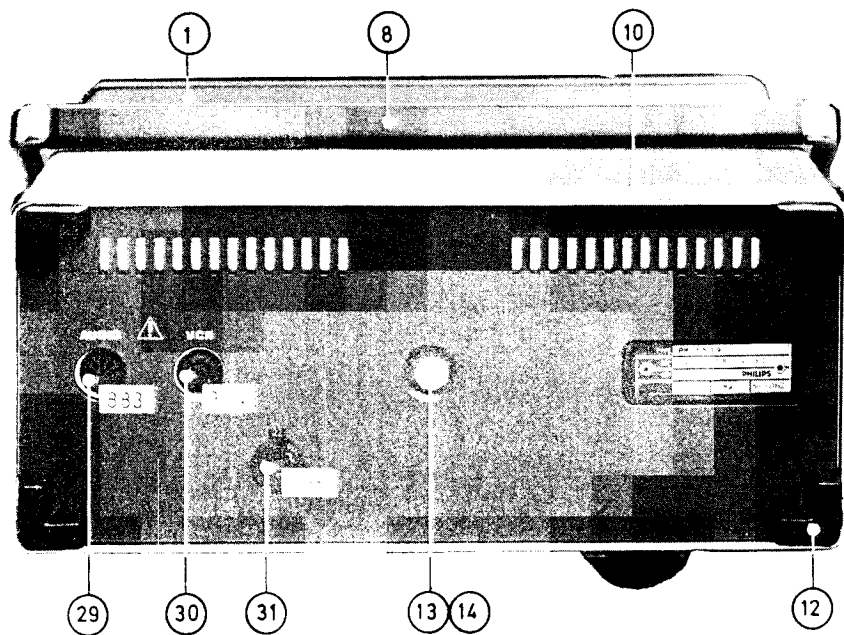

Fig. 23 Back view: spare parts

## 6.2. ELECTRICAL PARTS

Parts not mounted on printed circuit boards Units U1, U2, U3, U10, U11 are referred to in chapter 6.1. MECHANICAL PARTS, MISCELLANEOUS.

6.2.1. Unit 1

## TRANSISTORS/U1

301-305 4822 130 44195 BF494

## DIODES/U1

401-404 4822 130 30664 BB106

For Service Manuals Contact  
MAURITRON TECHNICAL SERVICES  
8 Cherry Tree Rd, Chinnor  
Oxon OX9 4QY  
Tel:- 01844-351694 Fax:- 01844-352554  
Email:- enquiries@mauritron.co.uk

ITEM	ORDERING NUMBER	FARAD	TOL (%)	VOLTS	REMARKS
CAPACITORS/U1					
501	4822 122 30043	10N	-20+80	63	CERAMIC PLATE
502	4822 122 31058	15P	2	100	CERAMIC PLATE
503	5322 125 54058	2,5-25P		250	TRIMMER
504	4822 121 50576	560P	1	250	POLYSTYRENE FOI
505	4822 122 30093	120P	2	100	CERAMIC PLATE
506	4822 122 30043	10N	-20+80	506	CERAMIC PLATE
507	4822 122 31067	33P	2	100	CERAMIC PLATE
508	4822 122 30043	10N	-20+80	63	CERAMIC PLATE
509	4822 124 20459	22MU		10	ELECTROLYTIC
510	4822 122 30103	22N	-20+80	63	CERAMIC PLATE
511	4822 122 31243	82P		100	CERAMIC PLATE
512	4822 122 31054	10P	2	100	CERAMIC PLATE
513	5322 125 54058	2,5-25P		250	TRIMMER
514	5322 121 54174	680P	1	250	POLYSTYRENE FOI
515	4822 121 50533	6,2N	1	63	POLYSTYRENE FOI
516	4822 122 30034	470P	2	100	CERAMIC PLATE
517	4822 122 30043	10N	-20+80	63	CERAMIC PLATE
518	4822 122 31081	100P	2		CERAMIC PLATE

ITEM	ORDERING NUMBER	OHM	TOL (%)	TYPE	REMARKS
RESISTORS/01					
601,602	5322 116 50872	61,9K	1	MR25	METAL FILM
603	5322 116 50508	487	1	MR25	METAL FILM
604	5322 116 54624	11,5K	1	MR25	METAL FILM
605	5322 116 54466	90,9	1	MR25	METAL FILM
606	5322 116 50417	162	1	MR25	METAL FILM
607	5322 116 54552	2,05K	1	MR25	METAL FILM
608	5322 116 54192	5,11	1	MR25	METAL FILM
609	5322 116 54712	147K	1	MR25	METAL FILM
610	5322 116 50482	33,2K	1	MR25	METAL FILM
611	5322 116 54518	383	1	MR25	METAL FILM
612	5322 116 54694	90,9K *	1	MR25	METAL FILM
613	5322 116 54557	1,21K	1	MR25	METAL FILM
614,615	5322 116 54466	90,9	1	MR25	METAL FILM
616	4822 116 51234	750	1	MR25	METAL FILM

\* may be altered (64K9...121K)

ITEM	ORDERING NUMBER	TYPE/DESCRIPTION
COILS/U1		
701	5322 157 54136	6MUH 1 COIL
X-TAL/U1		
751	4822 242 70323	X-TAL 4,433619MHZ ( FOR G-AND I-VERSION) (For N, M and MM version see 5.6.)

6.2.2. Unit 2

ITEM	ORDERING NUMBER	TYPE/DESCRIPTION
TRANSISTOR/U2		
301	4822 130 40902	BF240
302	5322 130 44237	BF450
DIODES/U2		
401	4822 130 30664	BB106
402	5322 130 34794	BA244
403	4822 130 30613	BAW62
404	5322 130 34794	BA244
405	4822 130 30613	BAW62
406	5322 130 34794	BA244
407	4822 130 30613	BAW62

see SGS 47

"

"

ITEM	ORDERING NUMBER	FARAD	TOL (%)	VOLTS	REMARKS
CAPACITORS/U2					
501	4822 122 31063	22P	2	100	CERAMIC PLATE
502	4822 122 30103	22N	-20+80	63	CERAMIC PLATE
503	4822 122 31069	30P	2	100	CERAMIC PLATE
504	5322 125 54058	2,5-25P		250	TRIMMER
505	4822 122 31076	68P	2	100	CERAMIC PLATE
506	4822 121 50566	1N	5	125	POLYSTYRENE FOIL
507	4822 122 31058	15P	2	100	CERAMIC PLATE
508	5322 125 54006	1-6P		400	TRIMMER
509	4822 122 30043	10N	-20+80	63	CERAMIC PLATE
510, 511	4822 122 31061	18P	2	100	CERAMIC PLATE
512	5322 125 54006	1-6P		400	TRIMMER
513	4822 122 30043	10N	-20+80	63	CERAMIC PLATE
514	4822 122 31074	56P	2	100	CERAMIC PLATE
515	4822 122 31056	12P	2	100	CERAMIC PLATE
516	5322 125 54006	1-6P		100	TRIMMER
517	4822 122 30043	10N	-20+80	63	CERAMIC PLATE
518-520	4822 122 30103	22N	-20+80	63	CERAMIC PLATE
521	5322 124 24202	2,2MU		63	ELECTROLYTIC

ITEM	ORDERING NUMBER	OHM	TOL (%)	TYPE	REMARKS
RESISTORS/U2					
601,602	5322 116 54696	100K	1	MR25	METAL FILM
603	5322 116 54192	5,11	1	MR25	METAL FILM
644,605	5322 116 55331	649K	1	MR25	METAL FILM
606	5322 116 54549	1K	1	MR25	METAL FILM
607,608	5322 116 55331	649K	1	MR25	METAL FILM
609	5322 116 54549	1K	1	MR25	METAL FILM
610,611	5322 116 55331	649K	1	MR25	METAL FILM
612	5322 116 54469	1K	1	MR25	METAL FILM
613	5322 116 50483	38,3K	1	MR25	METAL FILM
614	5322 101 44041	22K		LIN	CARBON POTM LIN + SWITC
615	5322 116 54561	1,33K	1	MR25	METAL FILM
616	5322 116 50766	147	1	MR25	METAL FILM
617	5322 116 50555	1,27	1	MR25	METAL FILM
618	5322 116 54541	825	1	MR25	METAL FILM
619	5322 116 54562	1,4K	1	MR25	METAL FILM

ITEM	ORDERING NUMBER	TYPE/DESCRIPTION
------	-----------------	------------------

COILS/U2		
----------	--	--

801	5322 157 54136	6MUH COIL
802	5322 158 10243	100MUH COIL

6.2.3. Unit 3

For Service Manuals Contact  
**MAURITRON TECHNICAL SERVICES**  
 8 Cherry Tree Rd, Chinnor  
 Oxon OX9 4QY  
 Tel:- 01844-351694 Fax:- 01844-352554  
 Email:- enquiries@mauritron.co.uk

ITEM	ORDERING NUMBER	TYPE/DESCRIPTION
------	-----------------	------------------

TRANSISTOR/U3		
---------------	--	--

301	4822 130 40938	BC548
302	4822 130 44197	BC558B
304,303	4822 130 44195	BF494
305-307	4822 130 40938	BC548

INTEGRATED CIRC./U3		
---------------------	--	--

351	5322 209 84695	TCA240
-----	----------------	--------

DIODES/U3		
-----------	--	--

401-405	4822 130 30613	BAW62
---------	----------------	-------

ITEM	ORDERING NUMBER	FARAD	TOL (%)	VOLTS	REMARKS
------	-----------------	-------	---------	-------	---------

CAPACITORS/U3					
---------------	--	--	--	--	--

501,502	4822 122 31243	82P	2	100	CERAMIC PLATE
503	5322 121 54174	680P	1	250	POLYSTYRENE FOIL
504,505	4822 122 30103	22N	-20+80	63	CERAMIC PLATE
506	4822 124 20468	33MU		16	ELECTROLYTIC
507	4822 122 30103	22N	-20+80	63	CERAMIC PLATE
508	4822 122 30103	22N	-20+80	63	CERAMIC PLATE
510	4822 122 31045	4P7	0,25	100	CERAMIC PLATE



ITEM	ORDERING NUMBER	OHM	TOL (%)	TYPE	REMARKS
RESISTORS/U3					
601	5322 116 54469	100	1	MR25	METAL FILM
602	5322 116 50635	1,47K	1	MR25	METAL FILM
603	5322 116 54567	1,69K	1	MR25	METAL FILM
604	5322 116 54541	825 see SGS 47	1	MR25	METAL FILM
605	5322 116 50561	590	1	MR25	METAL FILM
606	4822 100 10021	1K		LIN	TRIMMING POTM
607	5322 116 50508	487	1	MR25	METAL FILM
608	5322 116 54567	1,69K	1	MR25	METAL FILM
610	5322 116 50635	1,47K	1	MR25	METAL FILM
611	5322 116 54623	11K	1	MR25	METAL FILM
612	5322 116 54469	100	1	MR25	METAL FILM
613	5322 116 54641	19,6K	1	MR25	METAL FILM
614	5322 116 54494	187	1	MR25	METAL FILM
615	5322 116 50676	196	1	MR25	METAL FILM
616	5322 116 50664	2,05K	1	MR25	METAL FILM
617	5322 116 54589	3,83K	1	MR25	METAL FILM
618	5322 116 54603	7,5K	1	MR25	METAL FILM
619	5322 116 54623	11K	1	MR25	METAL FILM
620	5322 116 54469	100	1	MR25	METAL FILM
621	5322 116 54641	19,6K	1	MR25	METAL FILM
622	5322 116 50635	1,47K	1	MR25	METAL FILM
624	4822 120 10024	10K		LIN	TRIMMING POTMETER
625	5322 116 54469	100	1	MR25	METAL FILM
626	5322 116 50729	4,22K	1	MR25	METAL FILM
627,628	5322 116 54469	100	1	MR25	METAL FILM
629	5322 116 54506	287	1	MR25	METAL FILM
630	5322 116 54603	7,5K	1	MR25	METAL FILM
631	4822 100 10073	100R		LIN	TRIMMING POTM
633	4822 116 51233	681	1	MR25	METAL FILM
634	5322 116 54516	365	1	MR25	METAL FILM
635	5322 116 54506	287	1	MR25	METAL FILM
636	5322 116 50729	4,22K	1	MR25	METAL FILM

6.2.4. Unit 10

ITEM	ORDERING NUMBER	TYPE/DESCRIPTION
TRANSISTOR/U10		
301-303	4822 130 44121	BC338
304-310	4822 130 44196	BC548C
311-313	4822 130 44197	BC558B
315	4822 130 44257	BC547
316	4822 130 44256	BC557
317	4822 130 44121	BC338 see SGS 47
318	4822 130 44196	BC548C
319	4822 130 40938	BC548
320-321	5322 130 44847	BC548C * selected < serie/06
320-321	4822 130 44195	BF494 > serie/06
322	5322 130 44349	BC635
325,329	4822 130 44196	BC548C
330	4822 130 40938	BC548

ITEM	ORDERING NUMBER	TYPE/DESCRIPTION
INTEGRATED CIRC./U10		
314	5322 209 84862	SG3823N
323,324	5322 209 85803	MC1496A
326	5322 209 84111	CA3086
327,328	5322 209 85803	MC1496A
331	5322 209 84111	CA3086
336	5322 209 85971	0M320
350	5322 209 85508	N74LS221B
351	5322 209 85471	0Q5501
352	5322 209 85573	0Q5502
353	5322 209 85486	N74LS04N
354	5322 209 85832	N74LS26A
355,356	5322 209 85405	N74LS193N
357	5322 209 85974	SN74LS109AN-00
358	5322 209 84823	N74LS00A
359	5322 209 84996	N74LS10A
360	5322 209 85973	N74LS92A
361	5322 209 85604	N74LS11H
362-365	5322 209 84237	N74LS112N
366	5322 209 85002	N74LS164N
367	5322 209 85604	N74LS11N
368	5322 209 84995	N74LS08A
369	5322 209 84996	N74LS10A
370	5322 209 85569	N74LS20A
371	5322 209 84994	N74LS05N
372	5322 209 84823	N74LS00A
373	5322 209 85972	N74LS15N
374	5322 209 85801	N74LS09A
375	5322 209 84996	N74LS10A
376	5322 209 84823	N74LS00A
377	5322 209 85832	N74LS26A
378	5322 209 85801	N74LS09A
379	5322 209 84996	N74LS10A
380	5322 209 85504	N74LS12N
381	5322 209 84985	N74LS30A
384	5322 209 84823	N74LS00A
385	5322 209 85832	N74LS26A
386,387	5322 209 84996	N74LS10A
388-390	5322 209 85832	N74LS26A
391	5322 209 84996	N74LS10A
392	5322 209 85604	N74LS11N
393	5322 209 84997	N74LS36A
394	5322 209 85972	N74LS15N
395	5322 209 84237	N74LS112N
396	5322 209 14119	MOS-HEF4016BP

see SGS 47

## DIODES/U10

401-402	4822 130 30229	AAZ15
404,406	4822 130 30613	BAW62
407	4822 130 34173	BZX79-B5V6
408-414,	4822 130 30613	BAW62
416-424,		
426-430		
431	4822 130 34048	BZX75-C2V8
432,433	4822 130 34049	BZX75-C2V1
434,435	4822 130 30613	BAW62

For Service Manuals Contact  
**MAURITRON TECHNICAL SERVICES**  
 8 Cherry Tree Rd, Chinnor  
 Oxon OX9 4QY  
 Tel: 01844-351694 Fax: 01844-352554  
 Email: enquiries@mauritron.co.uk

ITEM	ORDERING NUMBER	FARAD	TOL (%)	VOLTS	REMARKS
CAPACITORS/U10					
501	4822 122 31175	1N	10	100	CERAMIC PLATE
502,503	4822 122 30103	22N	-20+80	63	CERAMIC PLATE
504	4822 122 30043	10N	-20+80	63	CERAMIC PLATE
505	4822 124 20453	68MU		6,3	ELECTROLYTIC
507	4822 122 30093	120P	2	100	CERAMIC PLATE
508	5322 122 34041	10N	10	100	CERAMIC PLATE
509	4822 121 40522	100N	10	100	POLYESTER FOIL
510	4822 122 30103	22N	-20+80	63	CERAMIC PLATE
511	4822 122 30043	10N	-20+80	63	CERAMIC PLATE
512	4822 122 31178	680P	10	100	CERAMIC PLATE
513		1P			CERAMIC PLATE
514,515	4822 124 20671	68MU		6,3	ELECTROLYTIC
516,517	5322 121 54174	680P	1	250	POLYSTYRENE FOIL
518,519	5322 121 54121	130N	1	63	POLYSTYRENE FOIL
520	4822 122 30103	22N	-20+80	63	CERAMIC PLATE
521	4822 124 20677	22MU	10		ELECTROLYTIC
522	4822 122 30103	22N	-20+80	63	CERAMIC PLATE
523-526	4822 121 40522	100N	10	100	POLYESTER FOIL
527	4822 122 31175	1N	10	100	CERAMIC PLATE
528	4822 122 30103	22N	-20+80	63	CERAMIC PLATE
529	4822 122 31038	2,7P	0,25	100	CERAMIC PLATE
530	4822 122 30103	22N	-20+80	63	CERAMIC PLATE
531	4822 124 20677	22MU		10	ELECTROLYTIC
532	4822 124 20672	150MU		6,3	ELECTROLYTIC
533,534	4822 124 20677	22MU		10	ELECTROLYTIC
535	4822 121 40427	220N	10	100	POLYESTER FOIL
536,537	4822 124 20677	22MU		10	ELECTROLYTIC
538	4822 124 20672	150MU		6,3	ELECTROLYTIC
539	4822 122 31067	33P	2	100	CERAMIC PLATE
540	4822 124 20586	150MU		16	ELECTROLYTIC
541,542	4822 124 20672	150MU		6,3	ELECTROLYTIC
543	4822 124 20762	2200MU		6,3	ELECTROLYTIC
544	4822 124 20698	10MU		25	ELECTROLYTIC

ITEM	ORDERING NUMBER	FARAD	TOL (%)	VOLTS	REMARKS
545	4822 122 30103	22N	-20+80	63	CERAMIC PLATE
546	4822 124 20476	10MU		25	ELECTROLYTIC
547,548	4822 122 31081	100P	2	100	CERAMIC PLATE
549	4822 122 30103	22N	-20+80	63	CERAMIC PLATE
550	4822 122 30034	470P	2	100	CERAMIC PLATE
551	4822 122 31081	100P	2	100	CERAMIC PLATE
552	4822 122 30103	22N	-20+80	63	CERAMIC PLATE
553	4822 122 31243	82P	2	100	CERAMIC PLATE
554	4822 122 30103	22N	-20+80	63	CERAMIC PLATE
555	4822 124 20468	33MU		16	ELECTROLYTIC
556-560	4822 122 30103	22N	-20+80	63	CERAMIC PLATE
561	4822 124 20459	22MU		10	ELECTROLYTIC
562-565	4822 122 30103	22N	-20+80	63	CERAMIC PLATE
566	4822 124 20459	22MU		10	ELECTROLYTIC
567,568	4822 122 31081	100P	2		CERAMIC PLATE
569	4822 124 20469	68MU		16	ELECTROLYTIC
570	5322 124 24202	2,2MU		63	ELECTROLYTIC
571	4822 124 20461	47MU		10	ELECTROLYTIC
572	5322 124 24202	2,2MU		63	ELECTROLYTIC
573-575	4822 121 40522	100N	10	100	POLYESTER FOIL
576	4822 124 20453	68MU		6,3	ELECTROLYTIC
577	4822 122 30103	22N	-20+80	63	CERAMIC PLATE
578	4822 122 31177	470P	10		CERAMIC PLATE
579	5322 124 24202	2,2MU		63	ELECTROLYTIC
580	4822 121 40239	47N	10	250	POLYESTER FOIL
581	4822 122 30103	22N	-20+80	63	CERAMIC PLATE
582	4822 124 20469	68MU		16	ELECTROLYTIC
583	4822 122 30103	22N	-20+80		CERAMIC PLATE
584	4822 122 31175	1N	10	100	CERAMIC PLATE
585	4822 124 20473	220MU		16	ELECTROLYTIC
590	4822 124 20469	68MU		16	ELECTROLYTIC
595	5322 121 40197	1MU	10	100	POLYESTER FOIL
596	see SGS 37				
597	see SGS 47				
598	see SGS 47				

ITEM	ORDERING NUMBER	OHM	TOL (%)	TYPE	REMARKS
<b>RESISTORS/U10</b>					
601	5322 111 94146	899-1,6		IC	WIRE-WOUND
602	5322 116 50581	2,49K	1	MR25	METAL FILM
603	5322 116 50415	1,15K	1	MR25	METAL FILM
604	5322 116 50581	2,49K	1	MR25	METAL FILM
605	4822 116 30122	330	5	NTC	NTC
606	5322 116 54525	511	1	MR25	METAL FILM
607	5322 116 50451	21,5K	1	MR25	METAL FILM
608	5322 116 51052	42,2	1	MR25	METAL FILM
609	5322 116 54595	5,11K	1	MR25	METAL FILM
610	5322 116 50484	4,64K	1	MR25	METAL FILM
611	5322 116 54525	511	1	MR25	METAL FILM
612	5322 116 54619	10K	1	MR25	METAL FILM
613	5322 116 50451	21,5K	1	MR25	METAL FILM
614	5322 116 50664	2,05K	1	MR25	METAL FILM
615	4822 116 30122	330	5	WTC	NTC
616, 617	5322 116 54595	5,11K	1	MR25	METAL FILM
619	5322 116 54446	56,2	1	MR25	METAL FILM
620	5322 116 50664	2,05K	1	MR25	METAL FILM
621	5322 116 50451	21,5K	1	MR25	METAL FILM
622	5322 116 54595	5,11K	1	MR25	METAL FILM
623	5322 116 50572	12,1K	1	MR25	METAL FILM
624	5322 116 50672	51,1K	1	MR25	METAL FILM
625	5322 116 50726	36,5K	1	MR25	METAL FILM
626	5322 116 54595	5,11K	1	MR25	METAL FILM
628	5322 116 54303	6,49K	1	MR25	METAL FILM
629	5322 116 54608	7,5K	1	MR25	METAL FILM
630	5322 116 54741	287K	1	MR25	METAL FILM
631	5322 116 50458	7,87K	1	MR25	METAL FILM
632	5322 116 54619	10K	1	MR25	METAL FILM
633	5322 116 54005	3,32K	1	MR25	METAL FILM
634	5322 116 55332	3,09K	0,1		METAL FILM
635	5322 116 54698	105K	1	MR25	METAL FILM

ITEM	ORDERING NUMBER	OHM	TOL (%)	TYPE	REMARKS
636	5322 116 50414	2,87K	1	MR25	METAL FILM
637-639	5322 116 54595	5,11K	1	MR25	METAL FILM
640	5322 116 54741	287K	1	MR25	METAL FILM
641-644	5322 116 54595	5,11K	1	MR25	METAL FILM
645	5322 116 55283	402K	1	MR25	METAL FILM
646	5322 116 54549	1K	1	MR25	METAL FILM
647	5322 116 50636	2,74K	1	MR25	METAL FILM
648	5322 116 54608	7K5	1	MR25	METAL FILM
649	5322 116 54714	154K	1	MR25	METAL FILM
650	5322 116 50608	6,19K	1	MR25	METAL FILM
651	5322 116 50451	21,5K	1	MR25	METAL FILM
652	5322 116 54279	115K	1	MR25	METAL FILM
653	5322 116 50608	6,19K	1	MR25	METAL FILM
654	5322 116 50636	2,74K	1	MR25	METAL FILM
655	5322 116 54009	562	1	MR25	METAL FILM
656	5322 116 54603	6,49K	1	MR25	METAL FILM
657	5322 116 54732	237K	1	MR25	METAL FILM
658	5322 116 54011	5,62K	1	MR25	METAL FILM
659	5322 116 54683	68,1K	1	MR25	METAL FILM
660	5322 116 54732	237K	1	MR25	METAL FILM
661	5322 116 50608	6,19K	1	MR25	METAL FILM
662, 663	5322 116 50484	4,64K	1	MR25	METAL FILM
664	4822 100 10036	4,7K		LIN	TRIMMING POTM
665	5322 116 50586	1,54K	1	MR25	METAL FILM
666	5322 116 54576	2,37K	1	MR25	METAL FILM
667, 668	5322 116 54552	1,05K	1	MR25	METAL FILM
669	5322 116 54549	1K	1	MR25	METAL FILM
670	5322 116 54595	5,11K	1	MR25	METAL FILM
671	4822 100 10029	2,2K		LIN	TRIMMING POTM
672	5322 116 54619	10K	1	MR25	METAL FILM
673	5322 116 54643	20,5K	1	MR25	METAL FILM
674	5322 116 50586	1,54K	1	MR25	METAL FILM
675	5322 116 54595	5,11K	1	MR25	METAL FILM
676	4822 110 63201	3,3M	10		CARBON
677	4822 110 63189	1,2M	10		CARBON

ITEM	ORDERING NUMBER	OHM	TOL (%)	TYPE	REMARKS
678,679	5322 116 54549	1K	1	MR25	METAL FILM
680,681	5322 116 50863	9,09	1	MR25	METAL FILM
682	5322 116 54617	9,53K	1	MR25	METAL FILM
683	5322 116 54595	5,1K	1	MR25	METAL FILM
684	5322 111 94146	899-1,6		IC	RES.NETW.
685	5322 116 54668	44,2K	1	MR25	METAL FILM
686	5322 116 50474	42,2K	1	MR25	METAL FILM
687	5322 116 54644	21K	1	MR25	METAL FILM
688	5322 116 54712	147K	1	MR25	METAL FILM
689	5322 116 50666	73,2K	1	MR25	METAL FILM
690	5322 116 50726	36,5K	1	MR25	METAL FILM
691	5322 116 50474	42,2K	1	MR25	METAL FILM
692	5322 116 54558	8,25K	1	MR25	METAL FILM
693	5322 116 54613	8,66K	1	MR25	METAL FILM
694	5322 116 50442	48,7K	1	MR25	METAL FILM
695	5322 116 54694	90,9K	1	MR25	METAL FILM
696	5322 116 54736	261K	1	MR25	METAL FILM
697	5322 116 54668	44,2K	1	MR25	METAL FILM
698	5322 116 54558	8,25K	1	MR25	METAL FILM
699	5322 116 54541	825	1	MR25	METAL FILM
700	5322 116 54603	6,49K	1	MR25	METAL FILM
701	5322 116 50583	5,9K	1	MR25	METAL FILM
702	5322 116 54442	51,1	1	MR25	METAL FILM
703	5322 116 54545	909	1	MR25	METAL FILM
704	5322 116 54538	787	1	MR25	METAL FILM
705,706	5322 116 54606	7,15K	1	MR25	METAL FILM
707	5322 116 50524	3,01K	1	MR25	METAL FILM
708	5322 116 54442	51,1	1	MR25	METAL FILM
709	5322 116 54469	100	1	MR25	METAL FILM
710	5322 116 54547	953	1	MR25	METAL FILM
711	5322 116 54442	51,1	1	MR25	METAL FILM
712	5322 116 50581	2,49K	1	MR25	METAL FILM
713	5322 116 54567	1,69K	1	MR25	METAL FILM
714	4822 100 10038	470		LIN	TRIMMING POTM
715	5322 116 50479	15,4	1	MR25	METAL FILM
716	5322 116 54637	17,8K	1	MR25	METAL FILM see SGS 47
717	5322 116 54442	51,1	1	MR25	METAL FILM
718	5322 116 54589	3,83K	1	MR25	METAL FILM
719	5322 116 50581	2,49K	1	MR25	METAL FILM
720	5322 116 54617	9,53K	1	MR25	METAL FILM
721	5322 116 54571	1,96K	1	MR25	METAL FILM
722	5322 116 54615	9,09K	1	MR25	METAL FILM see SGS 47
723	5322 116 54459	75	1	MR25	METAL FILM
724	5322 116 54734	249K	2	MR25	METAL FILM
725	5322 116 50677	21R5	1	MR25	METAL FILM
726	5322 116 54538	787	1	MR25	METAL FILM
727	5322 116 54558	8,25K	1	MR25	METAL FILM
728	5322 116 54683	68,1K	1	MR25	METAL FILM
729	5322 116 50524	3,01K	1	MR25	METAL FILM
730	5322 116 50586	1,54K	1	MR25	METAL FILM
731	5322 116 50581	2,49K	1	MR25	METAL FILM
732	5322 116 50729	4,22K	1	MR25	METAL FILM
733	5322 116 54519	402	1	MR25	METAL FILM
734	5322 116 50671	2,61K	1	MR25	METAL FILM
735	5322 116 50635	1,47K	1	MR25	METAL FILM
736	5322 116 50672	51,1K	1	MR25	METAL FILM
737	5322 116 54721	178K	1	MR25	METAL FILM
738	5322 116 54704	121K	1	MR25	METAL FILM } <series/06
739	5322 116 54689	82,5K	1	MR25	METAL FILM
737	5322 116 54714	154K	1	MR25	METAL FILM
738	5322 116 54698	105K	1	MR25	METAL FILM } from LO/06
739	5322 116 50567	95K3	1	MR25	METAL FILM } onwards
740,741	5322 116 50556	4,42K	1	MR25	METAL FILM
742	4822 116 51105	470	5		METAL FILM
743,744	5322 116 54459	75	1	MR25	METAL FILM
745,746	5322 116 54442	51,1	1	MR25	METAL FILM
747					select-in-test
748					select-in-test
749	5322 116 54592	4,02K	1	MR25	METAL FILM
750	5322 116 51051	8,66	1	MR25	METAL FILM
751	5322 116 54624	11,5K	1	MR25	METAL FILM
752	5322 116 50442	48,7K	1	MR25	METAL FILM
753	5322 116 50556	4,42K	1	MR25	METAL FILM
754	5322 116 54597	5,36K	1	MR25	METAL FILM
755	5322 116 54595	5,11K	1	MR25	METAL FILM

ITEM	ORDERING NUMBER	OHM	TOL (%)	TYPE	REMARKS	
	756	5322 116 50731	10,5K	1	MR25	METAL FILM
	757	5322 116 54587	3,65K	1	MR25	METAL FILM
	758	5322 116 54011	5,62K	1	MR25	METAL FILM
	759	5322 116 50559	27,4K	1	MR25	METAL FILM
	760	5322 116 54192	5,11	1	MR25	METAL FILM
	761	5322 116 50664	2,05K	1	MR25	METAL FILM
	762	5322 116 54001	15K	1	MR25	METAL FILM
	763	5322 116 50664	2,05K	1	MR25	METAL FILM
	764	5322 116 54625	11,8K	1	MR25	METAL FILM
	765	5322 116 50583	5,9K	1	MR25	METAL FILM
	766	5322 116 50664	2,05K	1	MR25	METAL FILM
	767	5322 116 54679	60,4K	1	MR25	METAL FILM
	768	5322 116 50872	61,9K	1	MR25	METAL FILM
	769	5322 116 54641	19,6K	1	MR25	METAL FILM
	771	5322 116 50664	2,05K	1	MR25	METAL FILM
	772	5322 116 54655	30,1K	1	MR25	METAL FILM
773,	774	4822 110 63187	1M	5		CARBON
	775	5322 116 54595	5,11K	1	MR25	METAL FILM
	776	5322 116 54686	75K	1	MR25	METAL FILM
777,	778	5322 116 54655	30,1K	1	MR25	METAL FILM
	779	5322 116 54686	75K	1	MR25	METAL FILM
	780	5322 116 54538	787	1	MR25	METAL FILM
	781	5322 116 50726	36,5K	1	MR25	METAL FILM
	782	5322 116 54637	17,8K	1	MR25	METAL FILM
	783	5322 116 54643	20,5K	1	MR25	METAL FILM
	784	5322 116 54655	30,1K	1	MR25	METAL FILM
	785	5322 116 54538	787	1	MR25	METAL FILM
786,	787	5322 116 50904	30,1	1	MR25	METAL FILM
	788	5322 116 50509	4,87K	1	MR25	METAL FILM
	789	5322 116 54606	7,15K	1	MR25	METAL FILM
	790	5322 116 50524	3,01K	1	MR25	METAL FILM
	792	5322 116 54549	1K	1	MR25	METAL FILM
	793	5322 116 50583	5,9K	1	MR25	METAL FILM
	794	5322 116 54549	1K	1	MR25	METAL FILM
	795	5322 116 50586	1,54K	1	MR25	METAL FILM
	796	5322 116 50571	715	1	MR25	METAL FILM
	797	5322 116 54536	750	1	MR25	METAL FILM
	798	5322 116 54624	11,5K	1	MR25	METAL FILM
	799	5322 116 54549	1K	1	MR25	METAL FILM
	800	4822 100 10051	22K		LIN	TRIMMING POTM
	801	5322 116 54538	787	1	MR25	METAL FILM
	802	5322 116 54536	750	1	MR25	METAL FILM
803,	804	5322 116 50904	30,1	1	MR25	METAL FILM
	805	5322 116 50509	4,87K	1	MR25	METAL FILM
	806	5322 116 54606	7,15K	1	MR25	METAL FILM
	807	5322 116 54624	11,5K	1	MR25	METAL FILM
	808	5322 116 54557	1,21K	1	MR25	METAL FILM
	809	4822 100 10051	22K		LIN	TRIMMING POTM
	810	5322 116 54536	750	1	MR25	METAL FILM
	811	4822 100 10038	470		LIN	TRIMMING POTM
	812	5322 116 50583	5,9K	1	MR25	METAL FILM
	813	5322 116 34014	1K	5	NTC	NTC
	814	5322 116 54442	51,1	1	MR25	METAL FILM
	815	5322 116 54617	9,53K	1	MR25	METAL FILM
	816	5322 116 50608	6,19K	1	MR25	METAL FILM
	817	5322 116 54494	187	1	MR25	METAL FILM
	818	5322 116 50524	3,01K	1	MR25	METAL FILM
	819	5322 116 50479	15,4K	1	MR25	METAL FILM
	820	5322 116 50567	95,3K	1	MR25	METAL FILM
	821	5322 116 54587	3,65K	1	MR25	METAL FILM
	822	5322 116 54619	10K	1	MR25	METAL FILM
	823	4822 100 10035	10K		LIN	TRIMMING POTM
	824	5322 116 54442	51,1	1	MR25	METAL FILM
	825	5322 116 54603	6,49K	1	MR25	METAL FILM
	826	5322 116 54571	1,96K	1	MR25	METAL FILM
827,	828	5322 116 54529	619	1	MR25	METAL FILM
	829	5322 116 54554	1,1K	1	MR25	METAL FILM
	830	5322 116 50586	1,54K	1	MR25	METAL FILM
831,	832	5322 116 50925	15,4	1	MR25	METAL FILM
	833	5322 116 50509	4,87K	1	MR25	METAL FILM

ITEM	ORDERING NUMBER	OHM	TOL (%)	TYPE	REMARKS
834	5322 116 54606	7,15K	1	MR25	METAL FILM
835	5322 116 54469	100	1	MR25	METAL FILM
836	5322 116 54005	3,32K	1	MR25	METAL FILM
837	5322 116 54469	100	1	MR25	METAL FILM
838	5322 116 54511	316	1	MR25	METAL FILM
840	5322 116 50603	357	1	MR25	METAL FILM
841	5322 116 54469	100	1	MR25	METAL FILM
842	5322 116 54606	7,15K	1	MR25	METAL FILM
843	5322 116 50509	4,87K	1	MR25	METAL FILM
844,845	5322 116 50925	15,4	1	MR25	METAL FILM
846	5322 116 54554	1,1K	1	MR25	METAL FILM
847	5322 116 50586	1,54	1	MR25	METAL FILM
848,849	5322 116 54529	619	1	MR25	METAL FILM
850	5322 116 54571	1,96K	1	MR25	METAL FILM
851	5322 116 54005	3,32K	1	MR25	METAL FILM
852	5322 116 54469	100	1	MR25	METAL FILM
853	5322 116 54442	51,1	1	MR25	METAL FILM
854	5322 116 50728	1,87K	1	MR25	METAL FILM
855	5322 116 54643	20,5K	1	MR25	METAL FILM
856	5322 116 50608	6,19K	1	MR25	METAL FILM
857	5322 116 54694	90,9K	1	MR25	METAL FILM
858	5322 116 54643	20,5K	1	MR25	METAL FILM
859	5322 116 54632	14,7K	1	MR25	METAL FILM
860,861	5322 116 50622	1,58K	1	MR25	METAL FILM
869	5322 116 54549	1K	1	MR25	METAL FILM
863	5322 116 50555	1,27K	1	MR25	METAL FILM
864	5322 116 54442	51,1	1	MR25	METAL FILM
865,866	5322 116 54619	10K	1	MR25	METAL FILM
867	5322 116 54665	40,2K	1	MR25	METAL FILM
868	5322 116 55258	511K	1	MR25	METAL FILM
869	5322 116 50557	46,4K	1	MR25	METAL FILM
870	5322 116 54619	10K	1	MR25	METAL FILM
871	5322 116 54635	16,9K	1	MR25	METAL FILM
872	5322 116 54552	1,05K	1	MR25	METAL FILM
873	5322 116 50484	4,64K	1	MR25	METAL FILM
874,875	5322 116 54643	20,5K	1	MR25	METAL FILM
876	5322 116 54549	1K	1	MR25	METAL FILM
877	4822 100 10079	47K		LIN	TRIMMING POTM
878	5322 116 54442	51,1	1	MR25	METAL FILM
880	5322 116 54466	90,9	1	MR25	METAL FILM

ITEM	ORDERING NUMBER	TYPE/DESCRIPTION
COILS/U10		
888	5322 158 10329	2,2 MUH COIL
889,890	5322 158 14004	15MUH COIL

For Service Manuals Contact  
**MAURITRON TECHNICAL SERVICES**  
8 Cherry Tree Rd, Chinnor  
Oxon OX9 4QY  
Tel:- 01844-351694 Fax:- 01844-352554  
Email:- enquiries@mauritron.co.uk

6.2.5. Unit 11

ITEM	ORDERING NUMBER	TYPE/DESCRIPTION
------	-----------------	------------------

## INTEGRATED CIRC./U11

351	4822 130 30959	ZTK33B
352	5322 209 85603	7812CU
353	5322 209 85724	7912CU
354	5322 209 85535	7805CU

## DIODES/U11

401,402	4822 130 30839	BY206
403,404	5322 130 32031	RECTIFIER SKB2/08L5A

ITEM	ORDERING NUMBER	FARAD	TOL (%)	VOLTS	REMARKS
------	-----------------	-------	---------	-------	---------

## CAPACITORS/U11

505	4822 124 20501	47MU		63	ELECTROLYTIC
506	4822 124 20537	220MU		63	ELECTROLYTIC
507	4822 122 30128	4,7N	10	100	CERAMIC PLATE
508	4822 124 20494	4,7MU		63	ELECTROLYTIC
509	4822 124 20529	1000MU		25	ELECTROLYTIC
510-511	4822 122 30103	22N	-20+80	63	CERAMIC PLATE
513	4822 124 20468	33MU		16	ELECTROLYTIC
514	4822 124 20529	1000MU		25	ELECTROLYTIC
515-517	4822 122 30103	22N	-20+80	63	CERAMIC PLATE
518	4822 124 20468	33MU		16	ELECTROLYTIC
519	5322 124 24084	2200MU		16	ELECTROLYTIC
520	4822 122 30103	22N	-20+80	63	CERAMIC PLATE
522	4822 124 20461	47MU		10	ELECTROLYTIC

ITEM	ORDERING NUMBER	OHM	TOL (%)	TYPE	REMARKS
------	-----------------	-----	---------	------	---------

## RESISTORS/U11

601	5322 116 50484	4,64K	1	MR25	METAL FILM
602	5322 116 54442	51,1	1	MR25	METAL FILM
604	5322 116 50555	1,27K	1	MR25	METAL FILM
605	5322 116 50926	40,2	1	MR25	METAL FILM
606	5322 116 50678	20,5	1	MR25	METAL FILM
607,608	5322 116 50452	10	1	MR25	METAL FILM
609	5322 116 50678	20,5	1	MR25	METAL FILM
610	5322 116 50926	40,2	1	MR25	METAL FILM
611	5322 116 54554	1,1K	1	MR25	METAL FILM
612	5322 116 54417	7,5	1	MR25	METAL FILM



6.2.6. VHF-UHF modulator 5322 218 64054

For experienced service workshops we propose to repair the modulator on the single component level.

Item	Ordering number	Type/Description	Farad	Tol (%)	Volts	Remarks
<b>Miscellaneous</b>						
751	5322 158 14138	Balance-transformer				
<b>Transistors</b>						
301 - 303	5322 130 44511	AF 387 up to LO 06 ...				
301 - 303	5322 130 41741	BF 967 from LO 07 ... onwards				
<b>Integrated circuits</b>						
351	5322 209 819 81	TCA 820 not available anymore				
351		TDA 0820T LO 17 ... onwards				
<b>Diodes</b>						
401	5322 130 34953	88 405 B				
402	5322 130 34478	88 113 up to LO 17 ...				
402, 404	5322 130 32281	88 130 LO 17 ... onwards				
403	5322 130 34953	88 405 B				

Item	Ordering number	Farad	Tol (%)	Volts	Remarks
<b>Capacitors</b>					
501, 502	5322 122 34049	820 P	-20/ +100	40	Ceramic plate up to LO 17 ...
501, 502	5322 122 31998	1,0 N	10	63	Chip cap. LO 17 ... onwards
503	4822 122 30103	22 N	-20/ + 80	63	Ceramic plate
504, 505	4822 122 30027	1,0 N	-20/ + 80	63	Ceramic plate
506	5322 122 34049	820 P	-20/ + 100	40	Ceramic plate up to LO 17 ...
506	5322 122 31998	1,0 N	10	63	Chip cap. LO 17 ... onwards
507	4822 122 30027	1,0 N	-20/ + 80	63	Ceramic plate
508	4822 122 31038	2,7 P	0,25 P	100	Ceramic plate up to LO 17 ...
508	5322 122 40411	0,68 P	0,25 P	63	Ceramic plate LO 17 ... onwards
509	5322 122 14011	2,0 P	0,25 P	160	Ceramic tubular
510	5322 122 14009	1,5 P	0,15 P	160	Ceramic tubular
511	4822 122 31069	39 P	2	100	Ceramic plate
512	4822 122 31072	47 P	2	100	Ceramic plate
513	4822 122 31054	10 P	2	100	Ceramic plate
514	4822 122 31063	22 P	2	100	Ceramic plate
515	4822 122 31045	4,7 P	0,25 P	100	Ceramic plate
516	4822 122 31054	10 P	2	100	Ceramic plate
517	5322 122 14009	1,5 P	0,15 P	160	Ceramic tubular
520	4822 122 31063	22 P	2	100	Ceramic plate
521	4822 122 31069	39 P	2	100	Ceramic plate LO 17 ... onwards

Item	Ordering number	Ohm	Tol (%)	Type	Remarks
<b>Resistors</b>					
601	5322 111 30605	56	5	SFR 16	Metal film
602	5322 116 50484	4,64 K	1	MR 25	Metal film
603	5322 116 54558	8,25 K	1	MR 25	Metal film
604	5322 116 54005	3,32 K	1	MR 25	Metal film
605	5322 116 54558	8,25 K	1	MR 25	Metal film
606	4822 100 10029	2,2 K	20	0,05 W	Carbon trimming potm.
607	5322 116 54005	3,32 K	1	MR 25	Metal film

For Service Manuals Contact  
**MAURITRON TECHNICAL SERVICES**  
 8 Cherry Tree Rd, Chinnor  
 Oxon OX9 4QY  
 Tel: 01844-351694 Fax: 01844-352554  
 Email: enquiries@mauritron.co.uk

up to LO 17 ...  
 LO 17 ... onwards

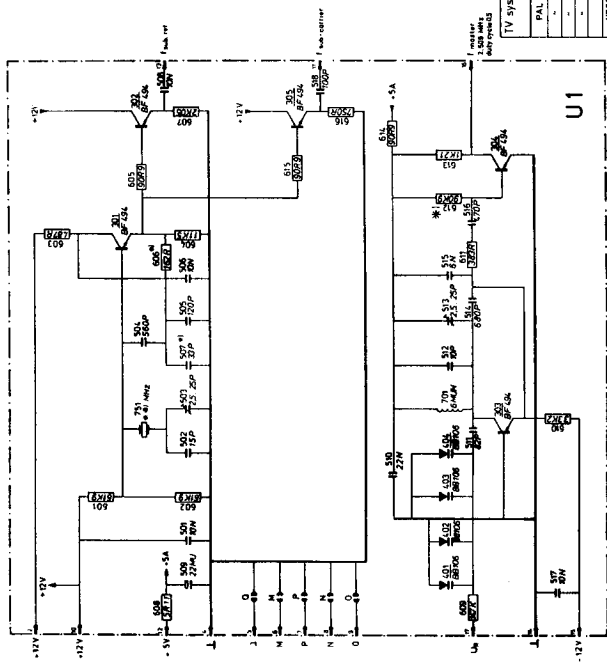

Fig. 24 Unit 1, master oscillator, circuit diagram

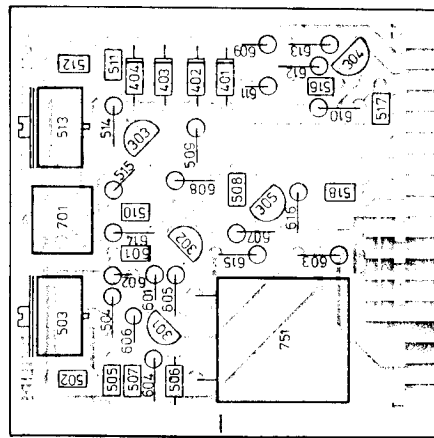

Fig. 25 Unit 1, component lay-out

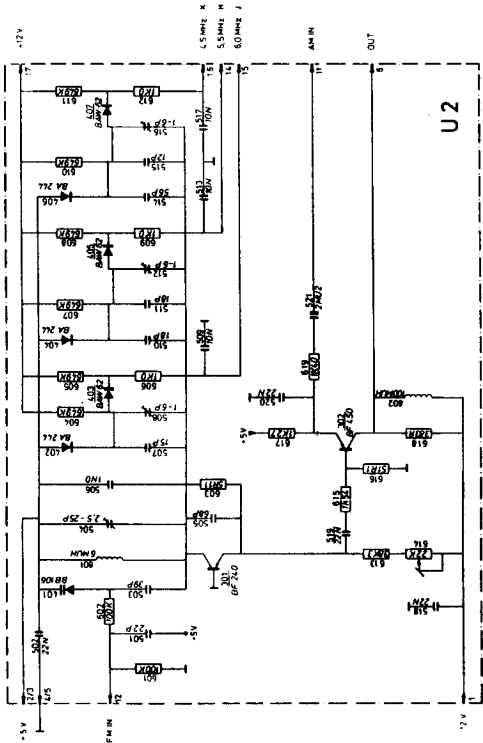

Fig. 26 Unit 2, sound oscillator and modulator, circuit diagram

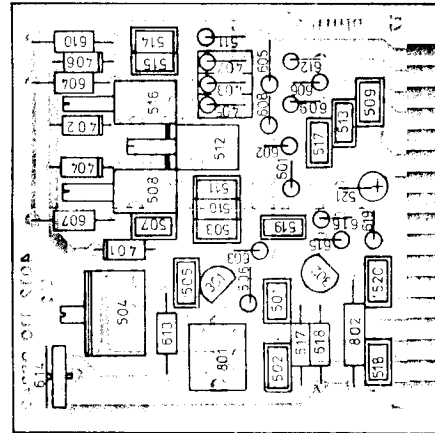

Fig. 27 Unit 2, component lay-out

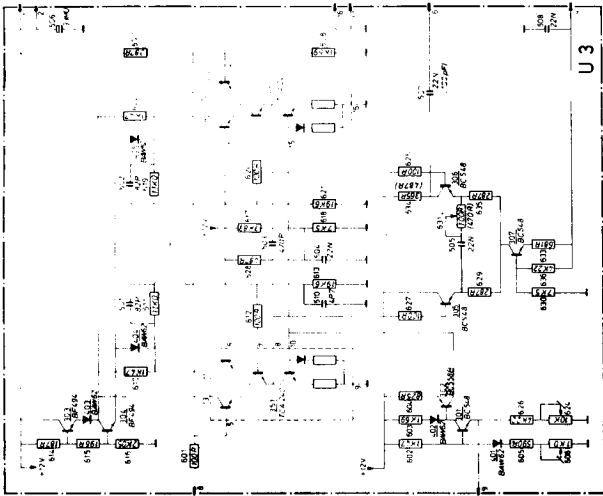

Fig. 28 Unit 3, multiburst oscillator, circuit diagram

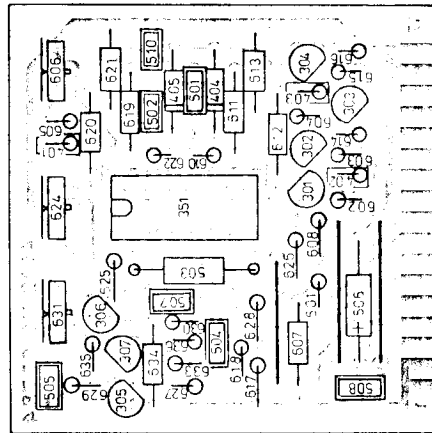
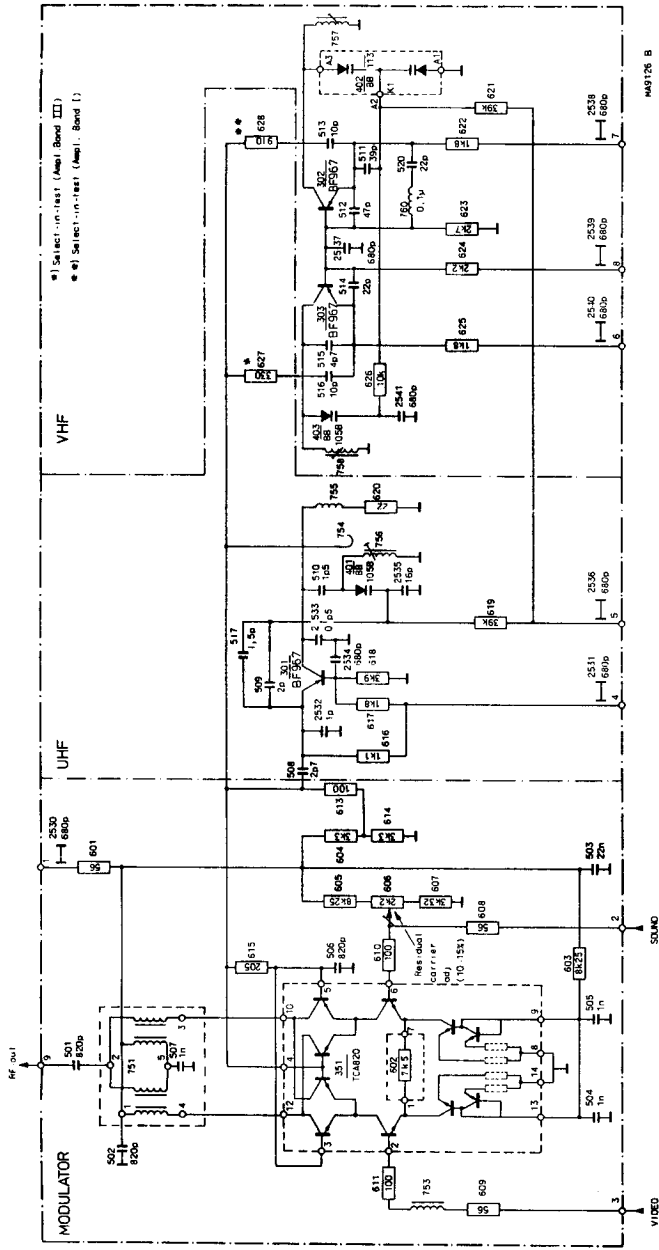

Fig. 29 Unit 3, component lay-out

For Service Manuals Contact  
**MAURITRON TECHNICAL SERVICES**  
 8 Cherry Tree Rd, Chinnor  
 Oxon OX9 4QY  
**Tel: 01844-351694 Fax: 01844-352554**  
**Email: enquiries@mauritron.co.uk**



For the overall circuit diagram and wiring of the RF pre-selection unit see Fig. 2 on page 20.

Fig. 32 VHF/UHF modulator, circuit diagram; until LO 16...

627 628 756 758

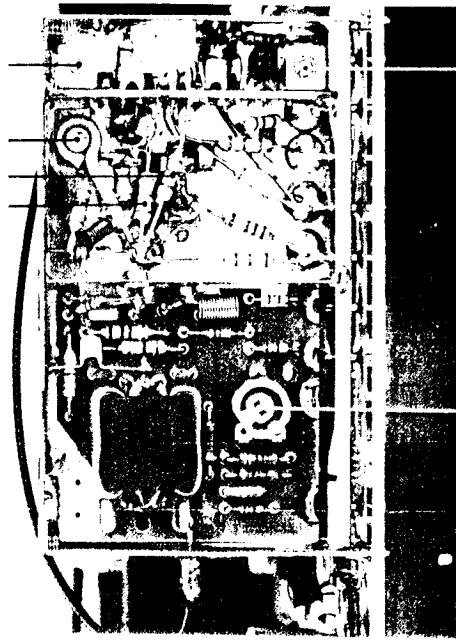

Fig. 33 VHF/UHF modulator, components

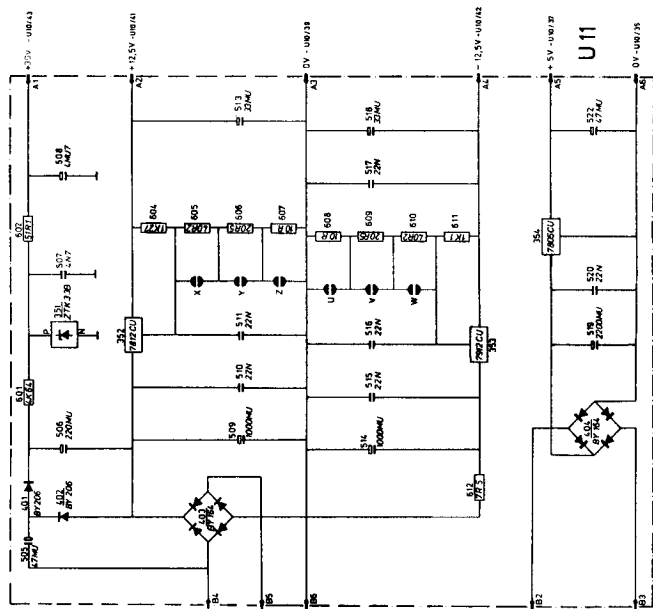

Fig. 30 Unit 11, power supply, circuit diagram

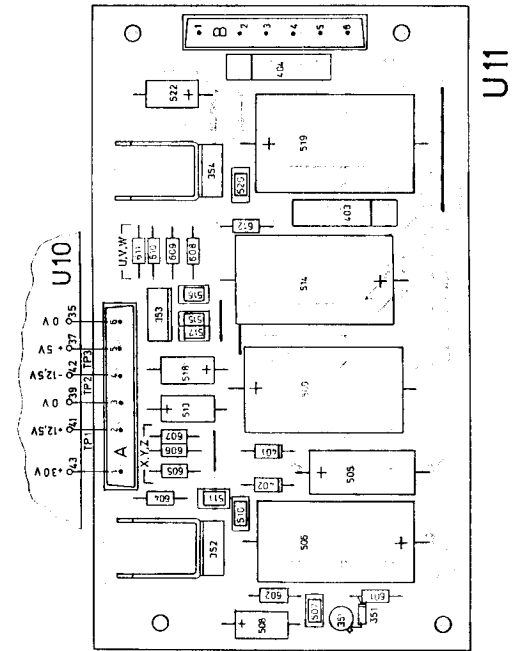
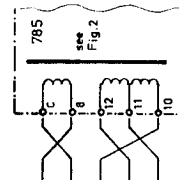
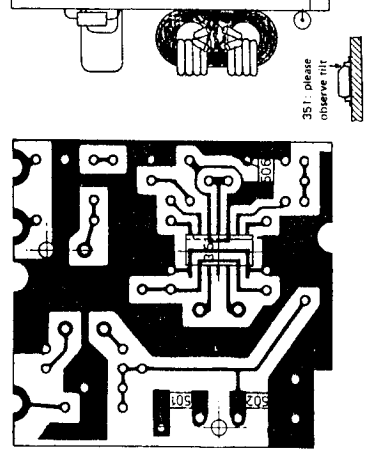
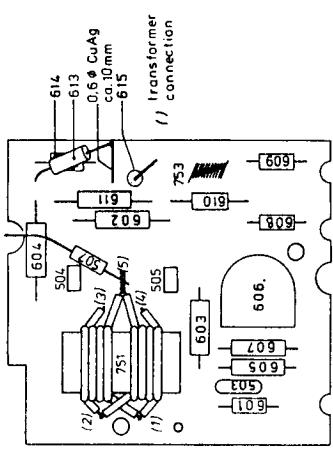
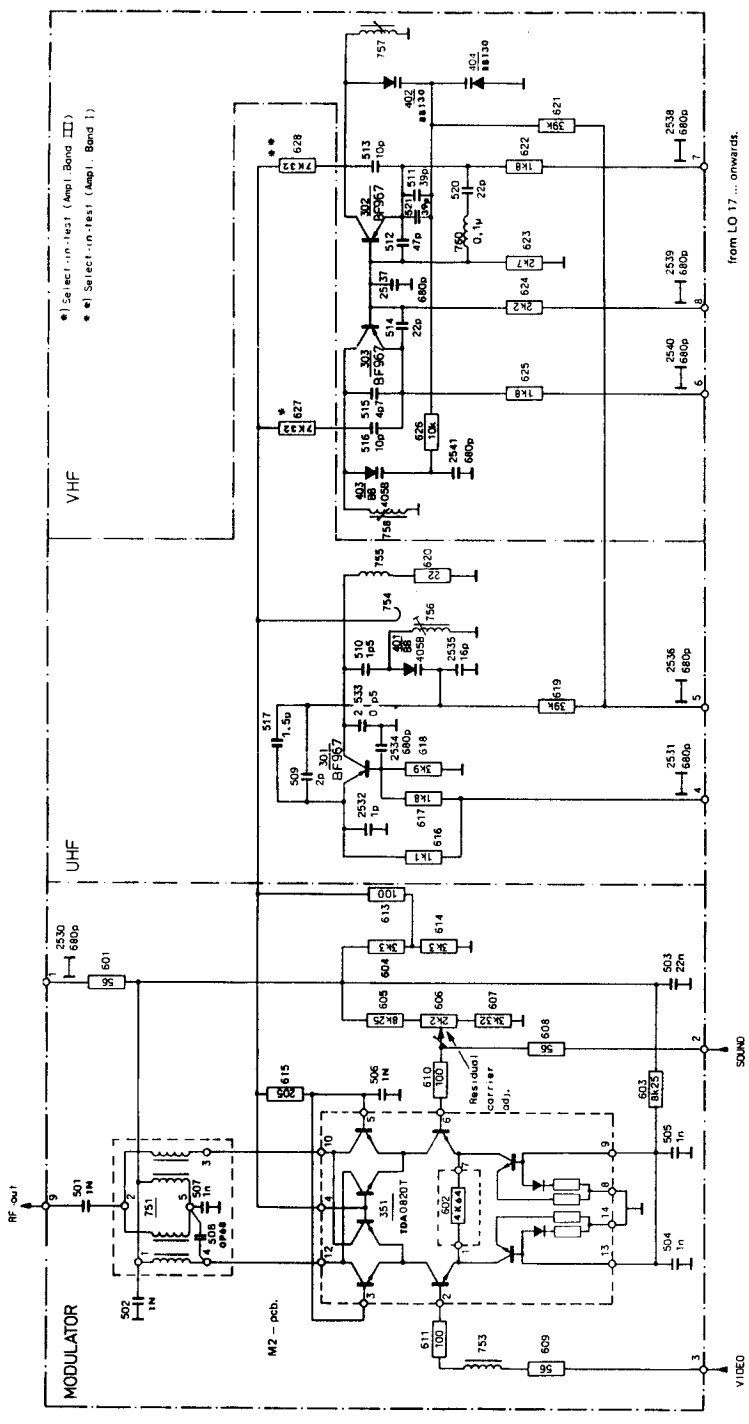

Fig. 31 Unit 11, component lay-out





M2 - pcb. of modulator  
series LO 17 . . . onwards

Fig. 32 a VHF/UHF modulator;  
series LO 17 . . . onwards

For Service Manuals Contact  
**MAURITRON TECHNICAL SERVICES**  
 8 Cherry Tree Rd, Chinnor  
 Oxon OX9 4QY  
 Tel: 01844-351694 Fax: 01844-352554  
 Email: enquiries@mauratron.co.uk

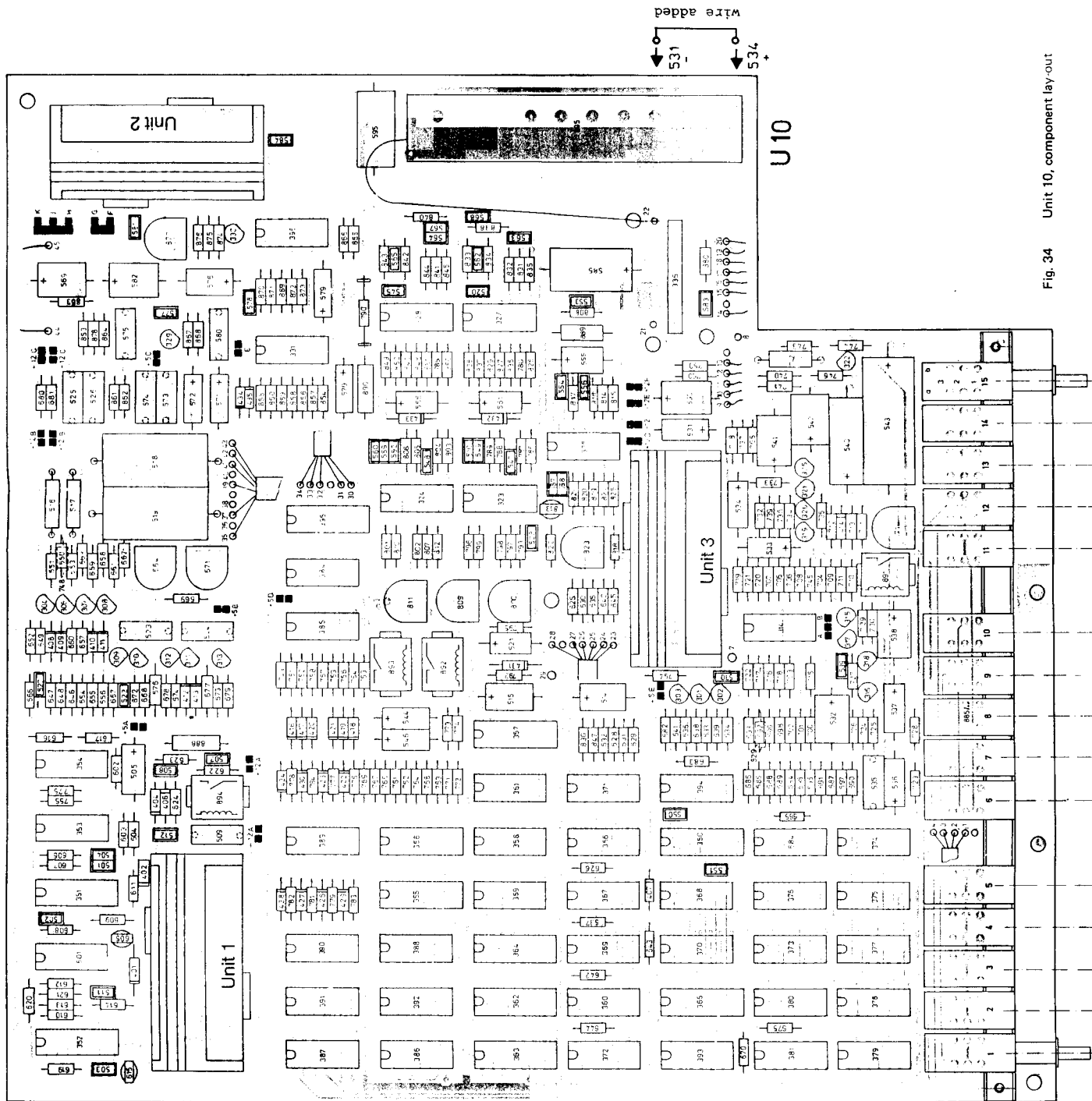

wire 387/1-395/3 added →  
 connection 395/2-395/3 separated

Fig. 34 Unit 10, component lay-out

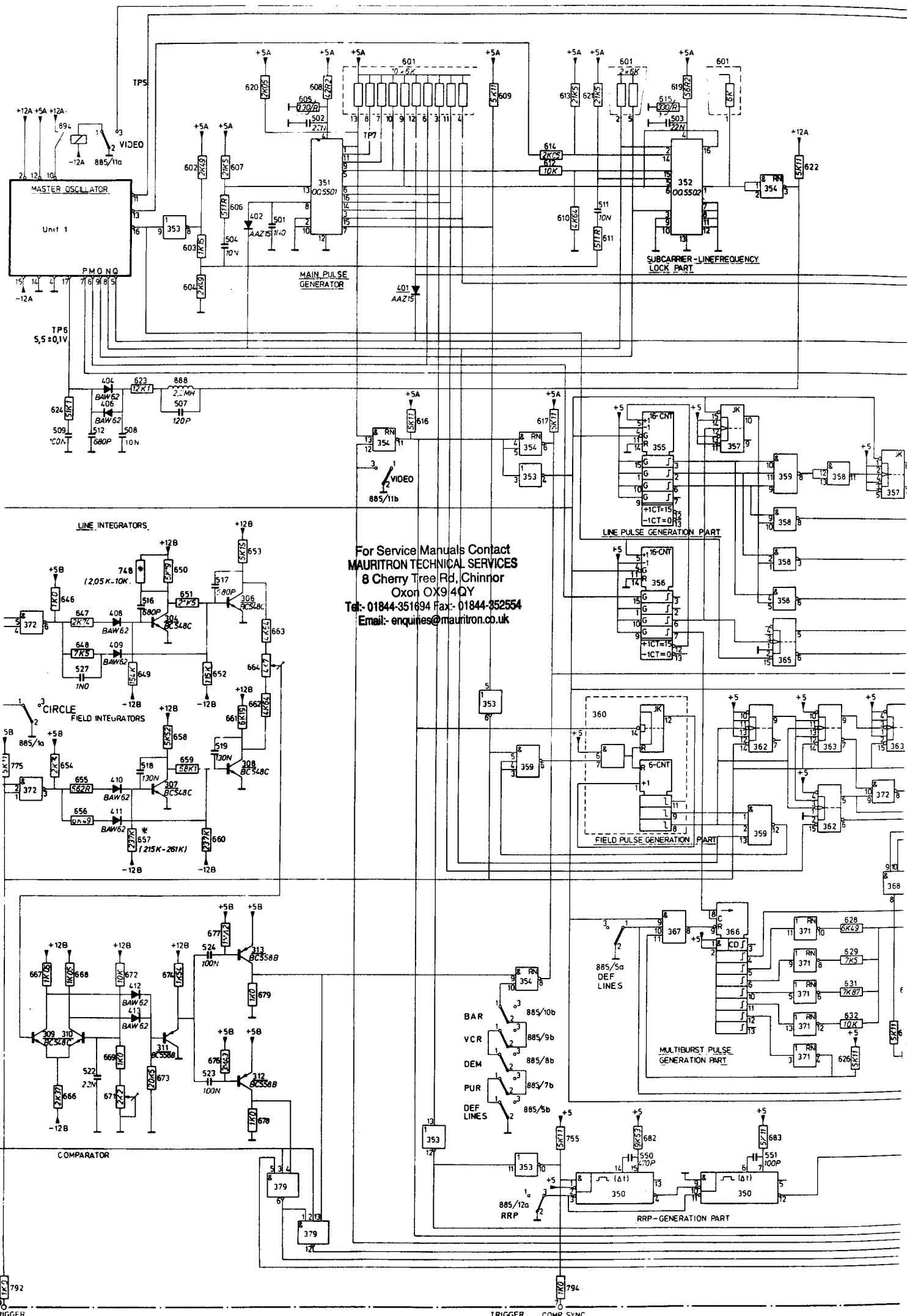

For Service Manuals Contact  
**MAURITRON TECHNICAL SERVICES**  
 8 Cherry Tree Rd, Chinnor  
 Oxon OX9 4QY  
 Tel: 01844-351694 Fax: 01844-352554  
 Email: enquiries@mauritron.co.uk

792  
 RIGGER  
 RAME

TRIGGER COMP SYNC

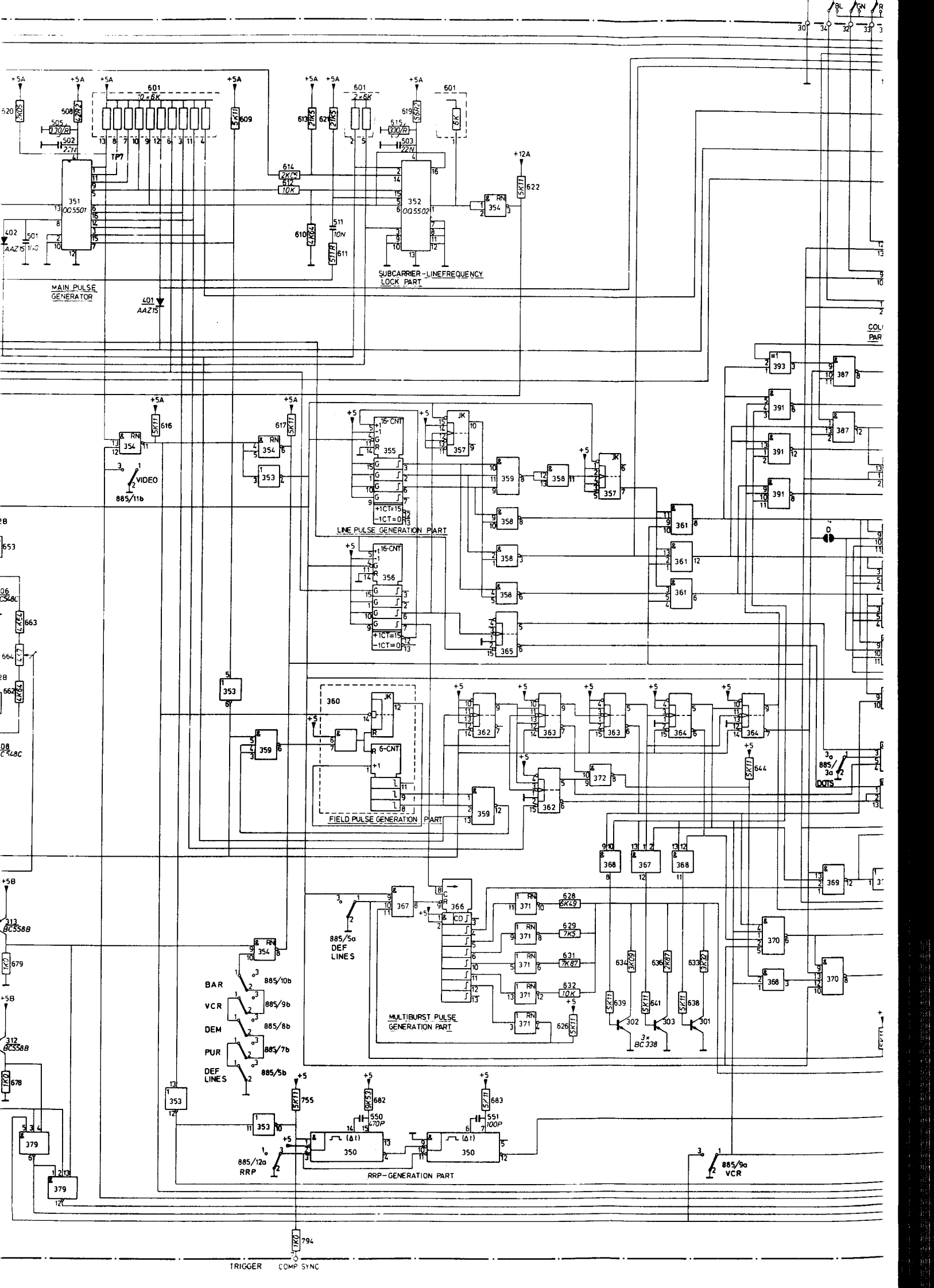

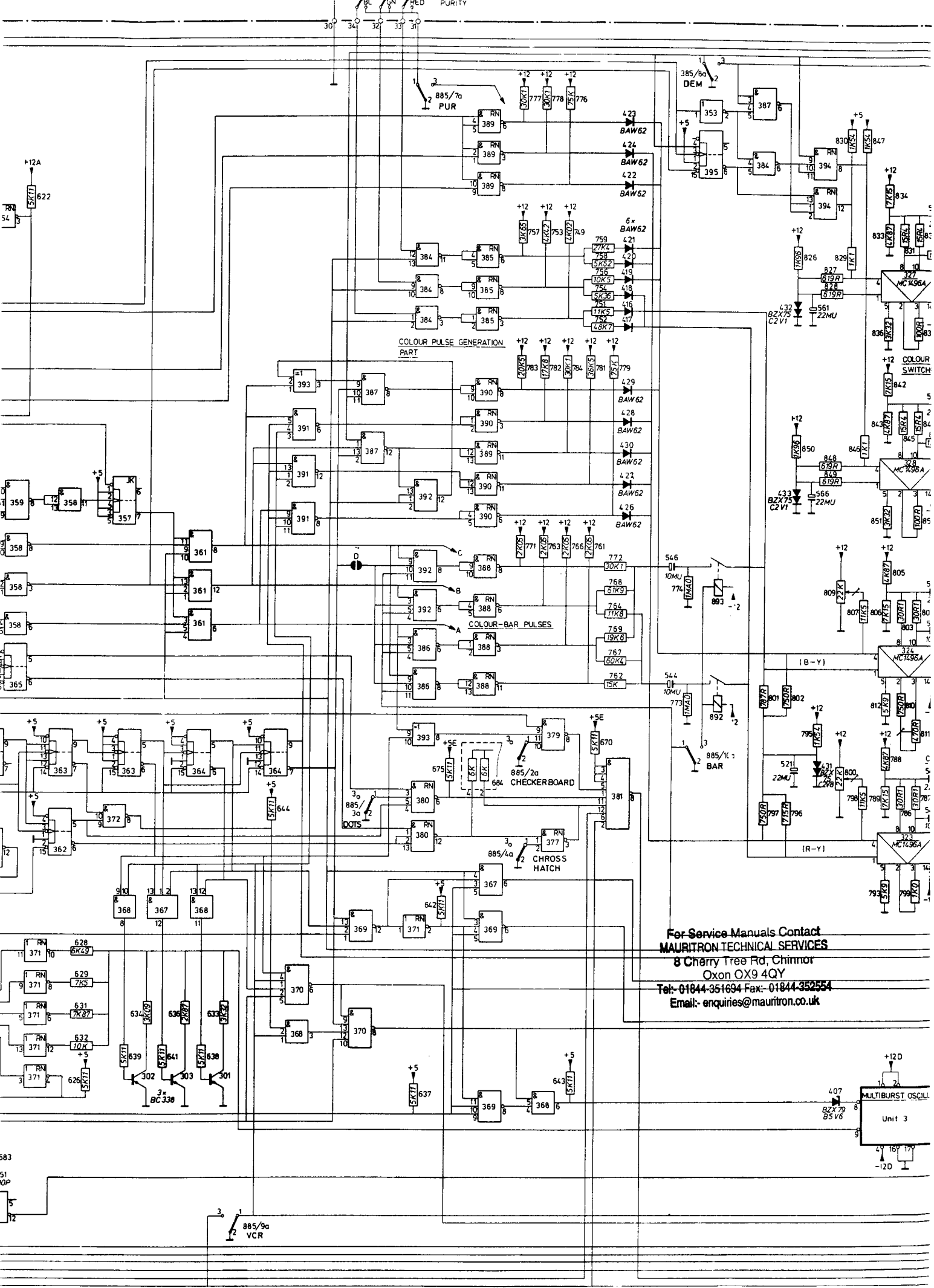

**For Service Manuals Contact**  
**MAURITRON TECHNICAL SERVICES**  
 8 Cherry Tree Rd, Chinnor  
 Oxon OX9 4QY  
 Tel: 01844-351694 Fax: 01844-352554  
 Email: enquiries@mauritron.co.uk

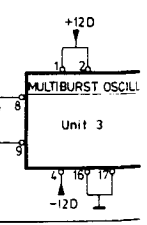



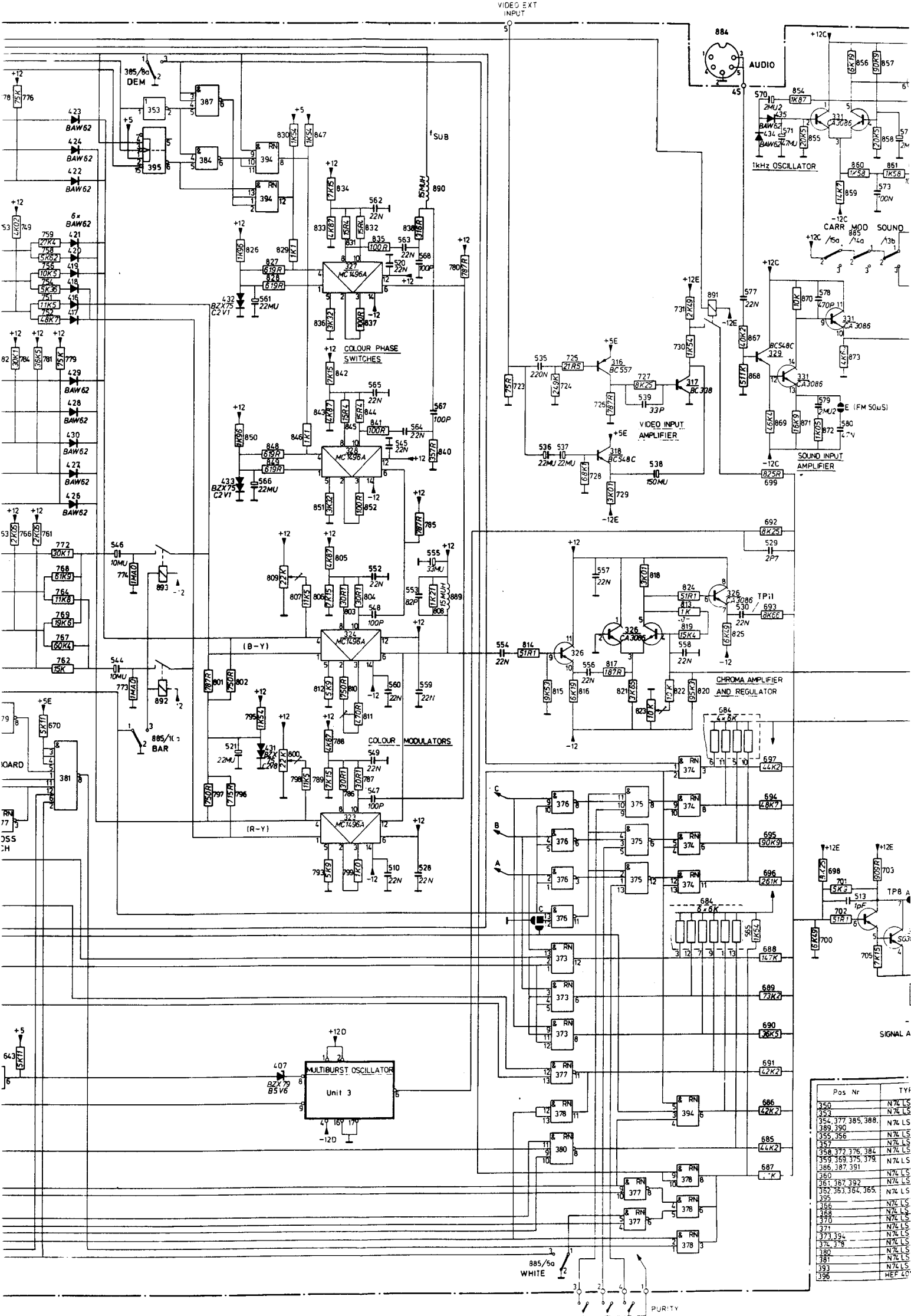

Pos	Nr	TYF
350		N7L LS
353		N7L LS
354, 377, 385, 388,		N7L LS
389, 390		N7L LS
355, 356		N7L LS
357		N7L LS
358, 372, 376, 384,		N7L LS
359, 363, 375, 378,		N7L LS
386, 387, 391		N7L LS
360		N7L LS
361, 367, 392		N7L LS
362, 363, 364, 365,		N7L LS
366		N7L LS
368		N7L LS
370		N7L LS
371		N7L LS
373, 394		N7L LS
374, 378		N7L LS
380		N7L LS
381		N7L LS
393		N7L LS
396		HEF 40

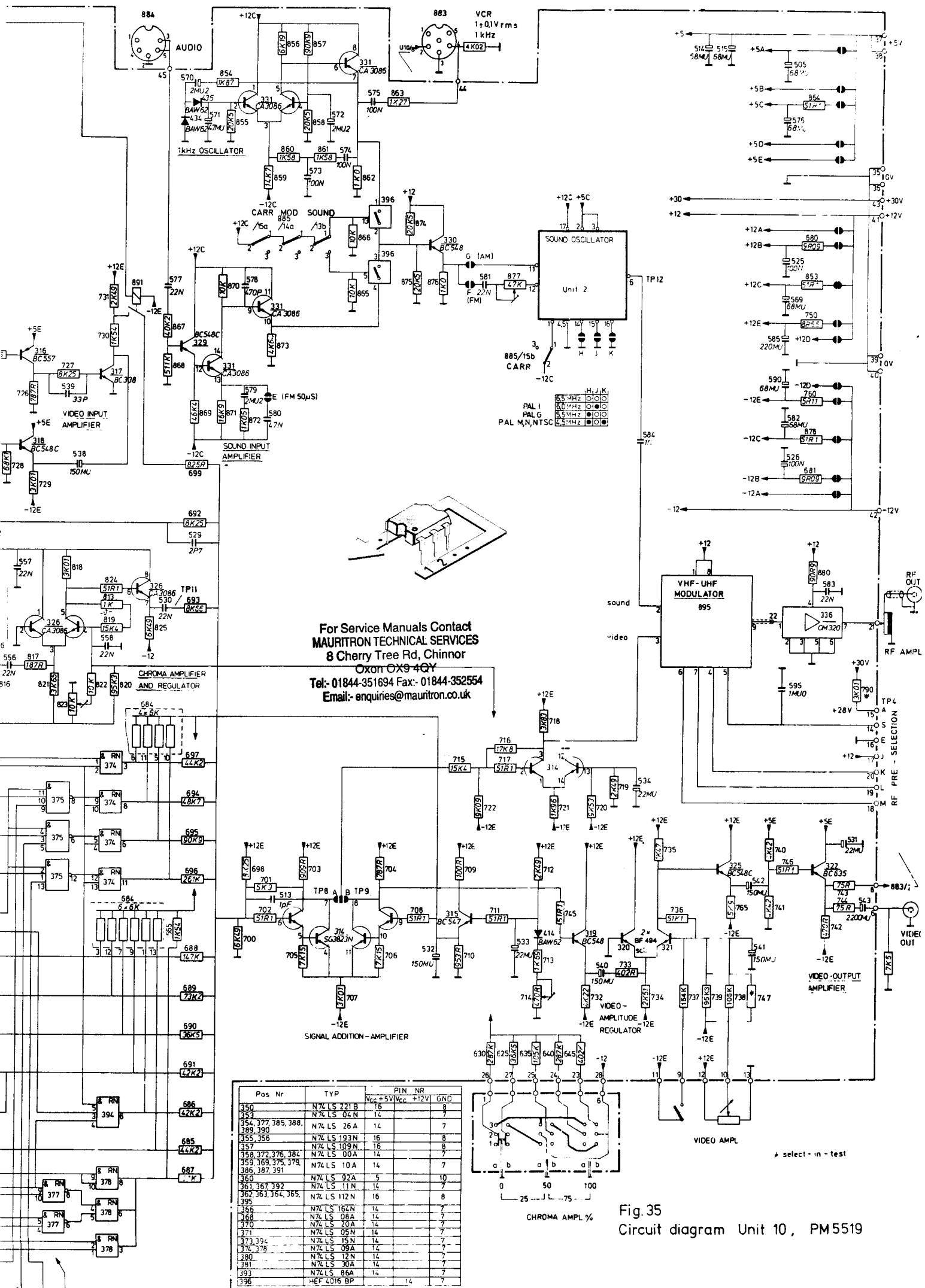

Fig. 35  
Circuit diagram Unit 10, PM5519