

NOTES:  
MULTIPLIER SHOWN IN x100 POSITION.  
ATTENUATOR SHOWN IN +10db POSITION.  
VOLTAGES MEASURED AT 1KHz (10 x 100).  
ALL RESISTORS IN OHMS UNLESS OTHERWISE SPECIFIED.

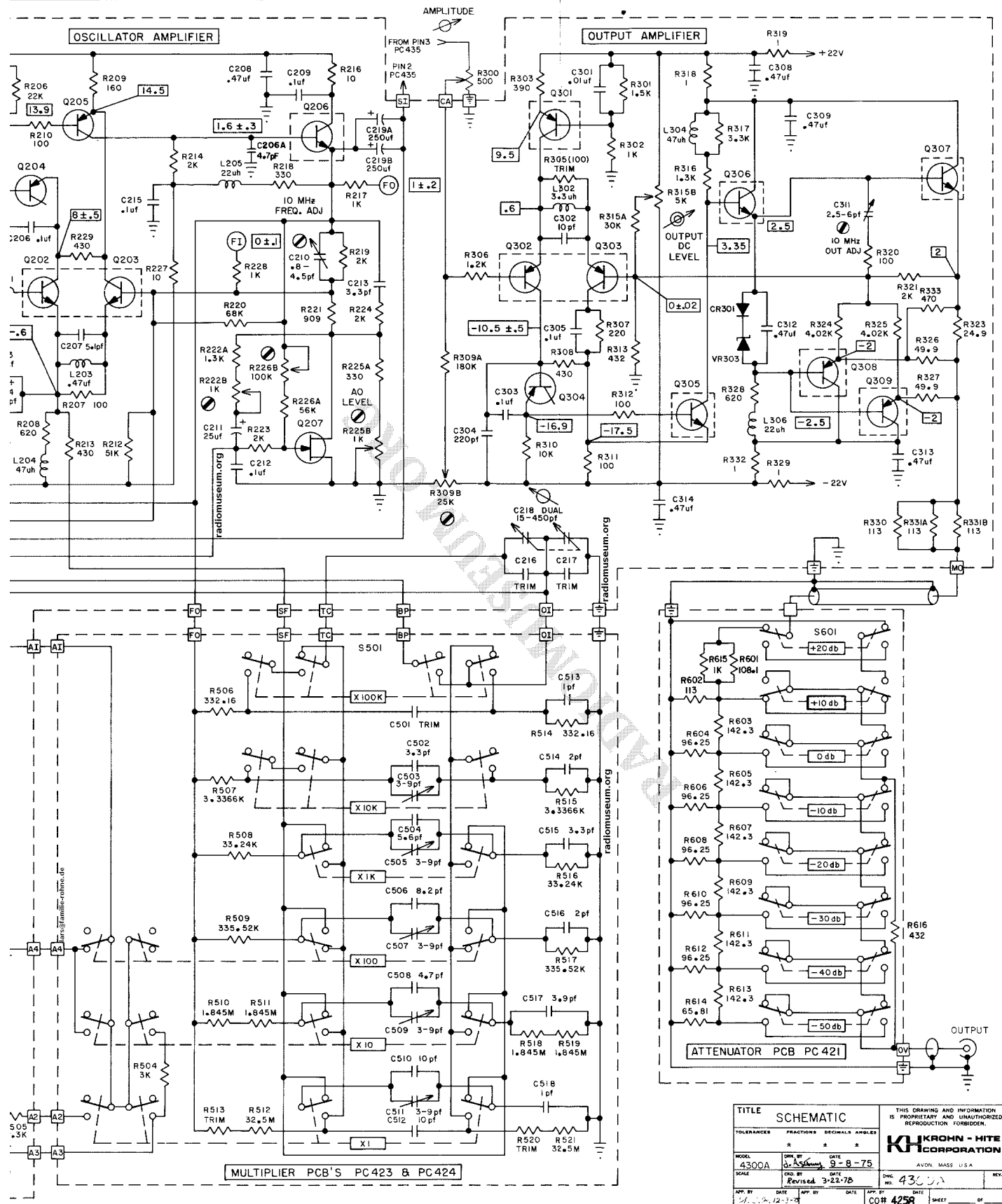

TITLE		SCHEMATIC		THIS DRAWING AND INFORMATION IS PROPRIETARY AND UNAUTHORIZED REPRODUCTION FORBIDDEN.	
TOLERANCES	FRACTIONS	DECIMALS	ANGLES	KROHN-HITE CORPORATION AVON, MASS. U.S.A.	
MODEL	REV. BY	DATE	REV. BY	DATE	REV.
4300A	3-8-75	3-8-75	3-8-75	3-8-75	4300A
SCALE	REVISED	DATE	SCALE	DATE	SCALE
	3-22-75				
APP. BY	DATE	APP. BY	DATE	APP. BY	DATE
	12-2-75				
CO# 4258			SHEET ___ OF ___		

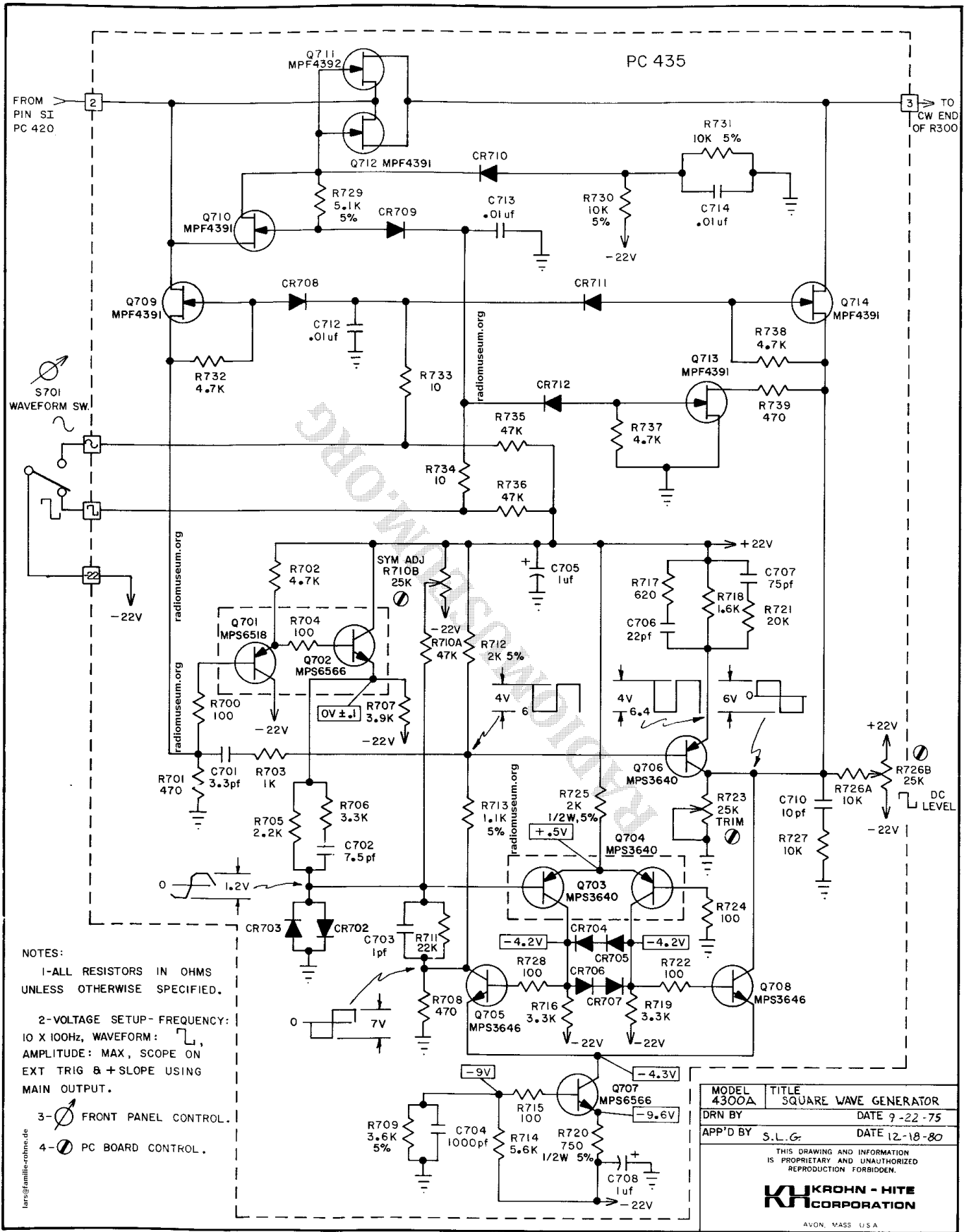

- NOTES:
- 1- ALL RESISTORS IN OHMS UNLESS OTHERWISE SPECIFIED.
  - 2- VOLTAGE SETUP- FREQUENCY: 10 X 100Hz, WAVEFORM: , AMPLITUDE: MAX, SCOPE ON EXT TRIG & +SLOPE USING MAIN OUTPUT.
  - 3- FRONT PANEL CONTROL.
  - 4- PC BOARD CONTROL.

MODEL 4300A	TITLE SQUARE WAVE GENERATOR
DRN BY	DATE 9-22-75
APP'D BY S.L.G.	DATE 12-18-80

THIS DRAWING AND INFORMATION IS PROPRIETARY AND UNAUTHORIZED REPRODUCTION FORBIDDEN.

**KROHN - HITE CORPORATION**

AVON, MASS. U.S.A.

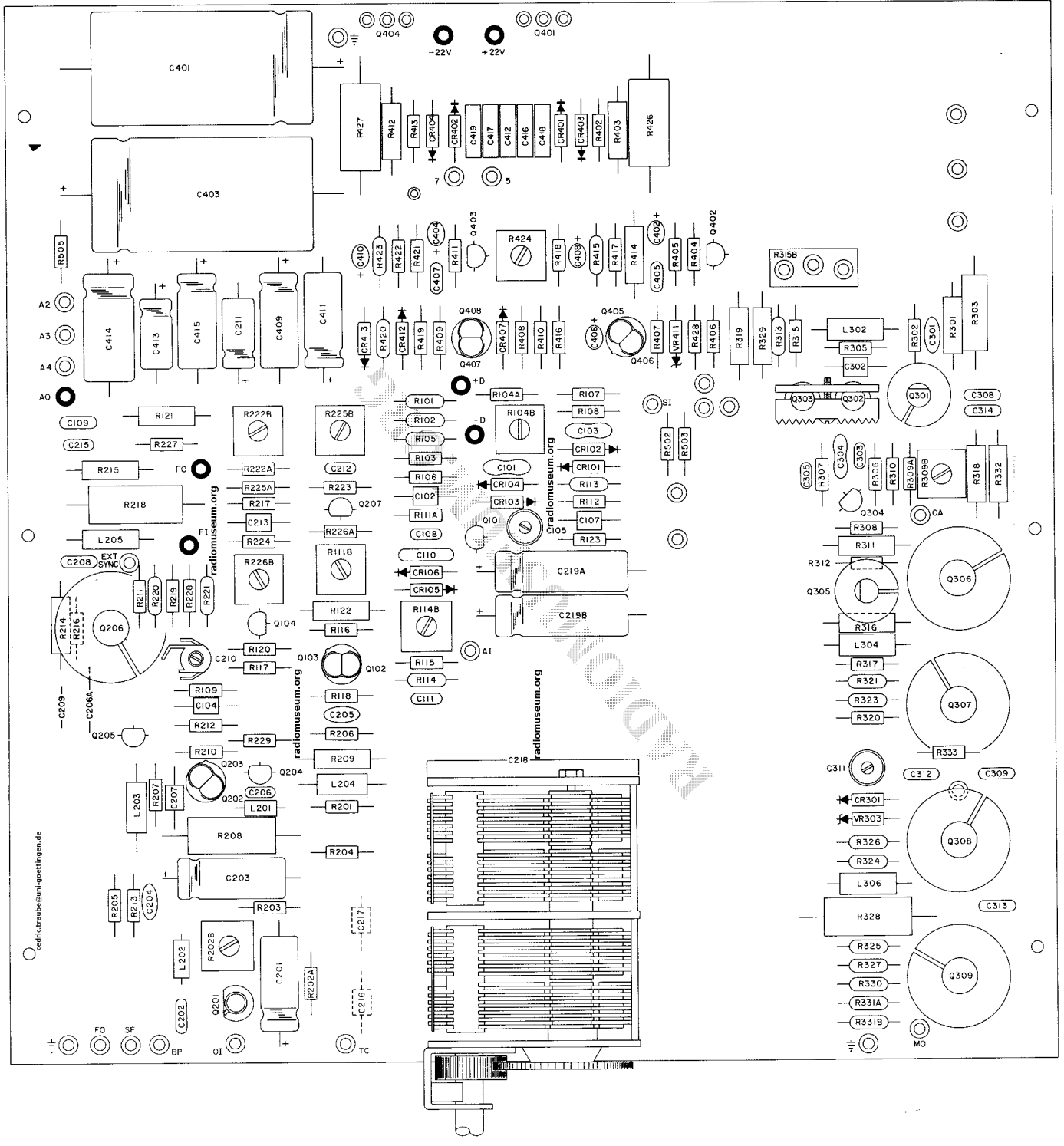

PC 420

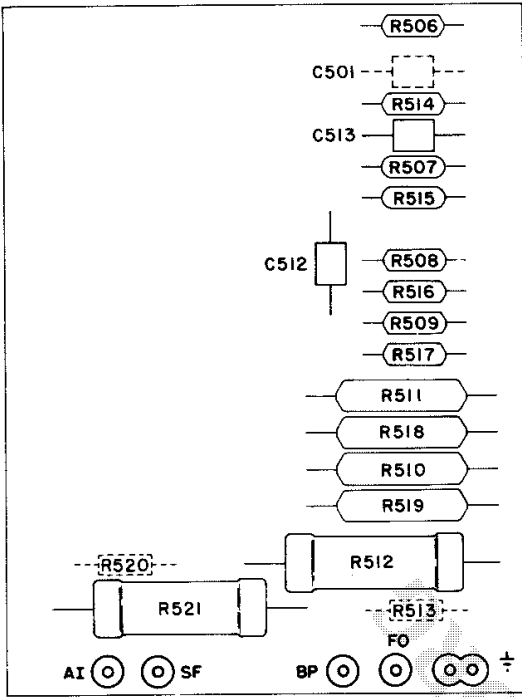

PC 423

radiomuseum.org

radiomuseum.org

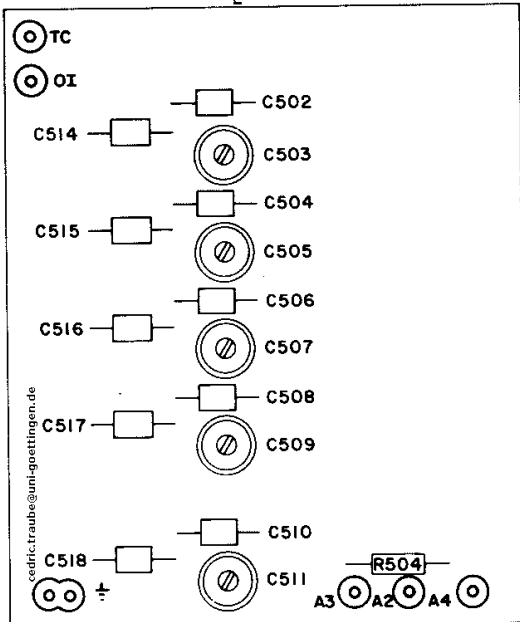

PC 424

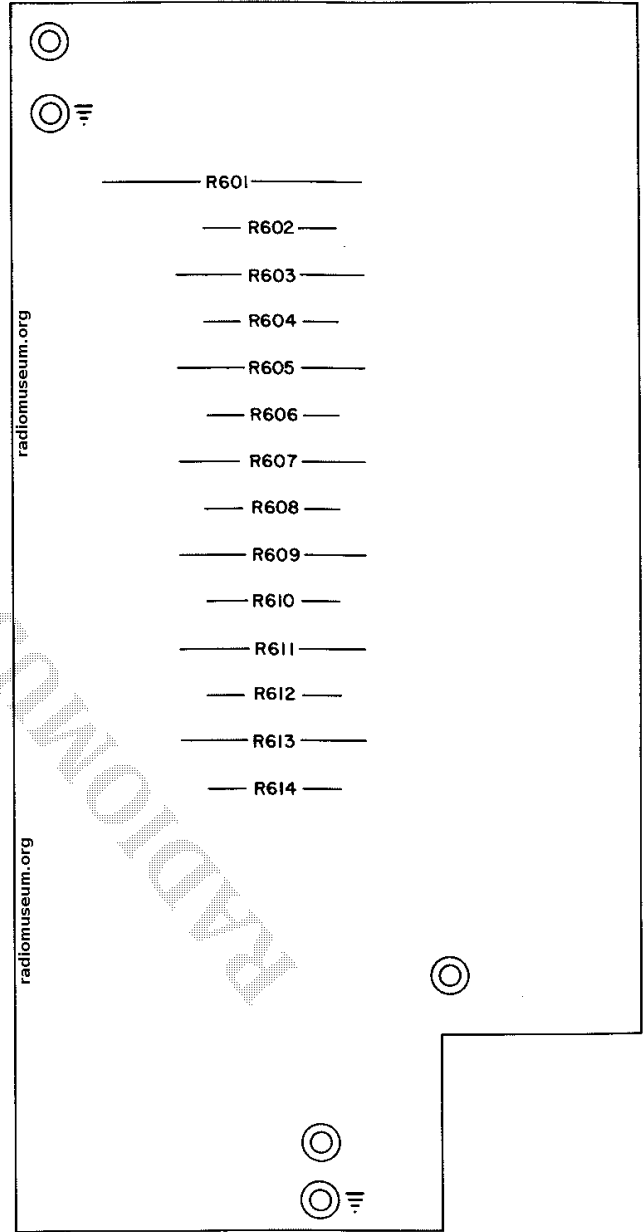

PC 421

radiomuseum.org

radiomuseum.org

RESISTORS

Symbol	Description	Mfr.	Part No.
R101	11.3K 1% 1/4W	AB	CC1132F
R102	2.21K 1% 1/4W	AB	CC2211F
R103	10K 5% 1/4W	AB	CB1035
R104A	15K 10% 1/4W	AB	CB1531
R104B	25K POT	BKM	72PM
R105	2.21K 1% 1/4W	AB	CC2211F
R106	10K 5% 1/4W	AB	CB1035
R107	1.5K 5% 1/4W	AB	CB1525
R108	510 5% 1/4W	AB	CB5115
R109	30K 5% 1/4W	AB	CB3035
R111A	10K 5% 1/4W	AB	CB1035
R111B	5K POT	BKM	72PM
R112	20K 5% 1/4W	AB	CB2035
R113	1K 1% 1/4W	AB	CC1001F
R114A	4.99K 1% 1/4W	AB	CC4991F
R114B	1K POT	BKM	72PM
R115	330 10% 1/4W	AB	CB3311
R116	10K 10% 1/4W	AB	CB1031
R117	5.1K 5% 1/4W	AB	CB5125
R118	330 10% 1/4W	AB	CB3311
R120	56K 10% 1/4W	AB	CB5630
R121	1 10% 1/2W	AB	EB10G1
R122	2.7K 10% 1/2W	AB	EB2721
R123	1K 5% 1/4W	AB	CB1025
R201	5.1K 5% 1/4W	AB	CB5125
R202A	5.1K 5% 1/4W	AB	CB125
R202B	5K POT	BKM	72PM
R203	10K 5% 1/4W	AB	CB1035
R204	10K 5% 1/4W	AB	CB1035
R205	10K 5% 1/4W	AB	CB1035
R206	22K 10% 1/4W	AB	CB2231
R207	100 5% 1/4W	AB	CB1015
R208	620 5% 2W	AB	HB6215
R209	160 5% 1/2W	AB	EB1615
R210	100 10% 1/4W	AB	CB1011
R211	51K 5% 1/4W	AB	CB5135
R212	51K 5% 1/4W	AB	CB5135
R213	430 5% 1/4W	AB	CB4315
R214	2K 5% 1/2W	AB	EB2025
R215	1 10% 1/2W	AB	EB10G1
R216	10 10% 1/4W	AB	CB1001
R217	1K 10% 1/4W	AB	CB1021
R218	330 10% 2W	AB	HB3311
R219	2K 1% 1/4W	AB	CC2001F
R220	68K 5% 1/4W	AB	CB6835
R221	909 1% 1/4W	AB	CC9090F
R222A	1.3K 5% 1/4W	AB	CB1325
R222B	1K POT	BKM	72PM
R223	2K 5% 1/4W	AB	CB2025
R224	2K 5% 1/4W	AB	CB2025
R225A	330 5% 1/4W	AB	CB3315
R225B	1K POT	BKM	72PM
R226A	56K 10% 1/4W	AB	CB5631
R226B	100K POT	BKM	72PM
R227	10 10% 1/4W	AB	CB1001
R228	1K 10% 1/4W	AB	CB1021
R229	430 5% 1/4W	AB	CB4315
R300	500 10% 2W	AB	J94972
R301	1.5K 5% 1/2W	AB	EB1525
R302	1K 5% 1/4W	AB	CB1025
R303	390 5% 1W	AB	GB3915
R305	TRIM		
R306	1.2K 10% 1/4W	AB	CB1221
R307	220 10% 1/4W	AB	CB2211
R308	430 5% 1/4W	AB	CB4315
R309A	180K 10% 1/4W	AB	CB1841
R309B	25K POT	BKM	72PM
R310	10K 10% 1/4W	AB	CB1031
R311	100 5% 1/2W	AB	EB1015
R312	100 10% 1/4W	AB	CB1011
R313	432 1% 1/4W	AB	CC4320F
R315A	30K	AB	CB3035
R315B	5K POT	KH	B3704
R316	1.3K 5% 1/2W	AB	EB1325
R317	3.3K 5% 1/4W	AB	CB3325
R318	1 10% 1/2W	AB	EB10G1

Symbol	Description	Mfr.	Part No.
R319	1 10% 1/2W	AB	EB10G1
R320	100 5% 1/4W	AB	CB1015
R321	2K 1% 1/4W	AB	CC2001F
R323	24.9 1% 1/2W	KH	835024
R324	4.02K 1% 1/4W	AB	CC4021F
R325	4.02K 1% 1/4W	AB	CC4021F
R326	49.9 1% 1/4W	AB	CC49R9F
R327	49.9 1% 1/4W	AB	CC49R9F
R328	620 5% 2W	AB	HB6215
R329	1 10% 1/2W	AB	EB10G1
R330	113 1% 1/4W	AB	CC1130F
R331A	113 1% 1/4W	AB	CC1130F
R331B	113 1% 1/4W	AB	CC1130F
R332	1 10% 1/2W	AB	EB10G1
R333	470 10% 1/4W	AB	CB4711
R401	100K 10% 1/4W	AB	CB1011
R402	3.3K 10% 1/4W	AB	CB3321
R403	390 10% 1/2W	AB	EB3911
R404	100 10% 1/4W	AB	CB1011
R405	1.2K 10% 1/4W	AB	CB1221
R406	47 10% 1/4W	AB	CB4701
R407	100 10% 1/4W	AB	CB1011
R408	47 10% 1/4W	AB	CB4701
R409	100 10% 1/4W	AB	CB1011
R410	2K 5% 1/4W	AB	CB2025
R411	100 10% 1/4W	AB	CB1011
R412	390 10% 1/2W	AB	EB3911
R413	3.3K 10% 1/4W	AB	CB3321
R414	3.6K 5% 1/2W	AB	EB3625
R415	4.22K 1% 1/4W	AB	CC4221F
R416	100 10% 1/4W	AB	CB1011
R417	20K 5% 1/4W	AB	CB2035
R418	2.55K 1% 1/4W	AB	CC2551F
R419	4.7K 10% 1/4W	AB	CB4721
R420	4.22K 1% 1/4W	AB	CC4221F
R421	100 10% 1/4W	AB	CB1011
R422	10K 10% 1/4W	AB	CB1031
R423	4.22K 1% 1/4W	AB	CC4221F
R424	1K POT	BKM	72PM
R426	220 10% 2W	AB	HB2211
R427	220 10% 2W	AB	HB2211
R428	24 5% 1/4W	AB	CB2405
R502	2K 5% 1/4W	AB	CB2025
R503	1K 5% 1/4W	AB	CB1025
R504	3K 5% 1/4W	AB	CB3025
R505	4.3K 5% 1/4W	AB	CB4325
R506	332.16 1/4% 1/8W	KID	M3-T1-332.16
R507	3.3366K 1/4% 1/8W	KID	M3-T1-3.3366K
R508	33.24K 1/4% 1/8W	KID	M3-T1-33.24K
R509	335.52K 1/4% 1/8W	KID	M3-T1-335.52K
R510	1.845M 1/4% 1/2W	KID	M5-T1-1.845M
R511	1.845M 1/4% 1/2W	KID	M5-T1-1.845M
R512	32.5M 2% 1W	KID	M13
R513	TRIM		
R514	332.16 1/4% 1/8W	KID	M3-T1-332.16
R515	3.3366K 1/4% 1/8W	KID	M3-T1-3.3366K
R516	33.24K 1/4% 1/8W	KID	M3-T1-33.24K
R517	335.52K 1/4% 1/8W	KID	M3-T1-335.52K
R518	1.845M 1/4% 1/2W	KID	M5-T1-1.845M
R519	1.845M 1/4% 1/2W	KID	M5-T1-1.845M
R520	TRIM		
R521	32.5M 2% 1W	KID	M13
R601	108.1 1% 3/4W	KID	M6-T1-108.1
R602	113 1% 1/4W	AB	CC1130F
R603	142.3 1% 1/4W	KID	M4-T1-142.3
R604	96.25 1% 1/8W	KID	M3-T1-96.25
R605	142.3 1% 1/4W	KID	M4-T1-142.3
R606	96.25 1% 1/8W	KID	M3-T1-96.25
R607	142.3 1% 1/4W	KID	M4-T1-142.3
R608	96.25 1% 1/8W	KID	M3-T1-96.25
R609	142.3 1% 1/4W	KID	M4-T1-142.3
R610	96.25 1% 1/8W	KID	M3-T1-96.25
R611	142.3 1% 1/4W	KID	M4-T1-142.3
R612	96.25 1% 1/8W	KID	M3-T1-96.25
R613	142.3 1% 1/4W	KID	M4-T1-142.3
R614	65.81 1% 1/8W	KID	M3-T1-65.81

CAPACITORS

Symbol	Description	Mfr.	Part No.
C101	200pf 5% 500V	ELM	DM15C201J
C102	3.3pf 10% 500V	ASP	9209-33910
C103	180pf 5% 500V	ELM	DM15C180J
C104	2pf 10% 500V	ASP	9208-20910
C105	3-9pf TRIMMER	STT	75-TRIKO-02-3/9pf
C107	2pf 10% 500V	ASP	9208-20910
C108	.1mf 20% 100V	ERT	8131-100-651-104M
C109	.47mf 20% 100V	ERT	8131-100-651-474M
C110	1mf +80%-20% 25V	SP	5C023105D8250B3
C111	.1mf 20% 100V	ERT	8131-100-651-104M

Symbols	Description	Mfr.	Part No.
C201	100mf 6V	SP	30D107G006CC4
C202	.47mf 20% 100V	ERT	8131-100-651-474M
C203	100mf 25V	SP	30D107G025DD4
C204	1000pf 20% 500V	SP	C023B501E102M
C205	1000pf 20% 500V	SP	C023B501E102M
C206	.1mf 20% 100V	ERT	8131-100-651-104M
C206A	4.7pF 10% 500V	QC	TYPE QC
C207	5.1pf 10% 500V	ASP	P210-51910
C208	.47mf 20% 100V	ERT	8131-100-651-474M
C209	.1mf 20% 100V	ERT	8131-100-651-104M
C210	.8-4.5pf TRIMMER	ERT	561-013

CAPACITORS (Cont.)							
Symbol	Description	Mfr.	Part No.	Symbol	Description	Mfr.	Part No.
C211	25mf	SP	30D256H016BB4	C411	20mf	SP	30D206G050CC4
C212	.1mf 20%	ERT	8131-100-651-104M	C412	.01mf 20%	SP	C0238501G103M
C213	3.3pf 10%	ASP	9209-33910	C413	25mf	SP	30D256G016884
C214	TRIM			C414	250mf	SP	30D257G006DD4
C215	.1mf 20%	ERT	8131-100-651-104M	C415	100mf	SP	30D107G006CC4
C216	TRIM	ASP	CERAMIC (JEFFER)	C416	.01mf 20%	SP	C0238501G103M
C217	TRIM	ASP	CERAMIC (JEFFER)	C417	.01mf 20%	SP	C0238501G103M
C218	15-450pf	DUAL	5084-2-450-LH-G25	C418	.01mf 20%	SP	C0238501G103M
C219A	250mf	6V	30D257G006DD4	C419	.01mf 20%	SP	C0238501G103M
C219B	250mf	6V	30D257G006DD4				
C301	.01mf 20%	ERT	8121-100-651-103M	C501	TRIM	ASP	CERAMIC (JEFFER)
C302	10pf 10%	ASP	9213-10110	C502	3.3pf 10%	ASP	9209-33910
C303	.1mf 20%	ERT	8131-100-651-104M	C503	3-9pf TRIMMER	STT	75-TRIKO-02-3/9pf
C304	220pf 10%	ELM	DM15C221K	C504	5.6pf 10%	ASP	9210-56910
C305	.1mf 20%	ERT	8131-100-651-104M	C505	3-9pf TRIMMER	STT	75-TRIKO-02-3/9pf
C308	.47mf 20%	ERT	8131-100-651-474M	C506	8.2pf 10%	ASP	9212-82910
C309	.47mf 20%	ERT	8131-100-651-474M	C507	3-9pf TRIMMER	STT	75-TRIKO-02-3/9pf
C311	2.5-6pf TRIMMER	STT	75-TRIKO-02-2.5/6pf	C508	4.7pf 10%	ASP	9212-82910
C312	.47mf 20%	ERT	8131-100-651-474M	C509	3-9pf TRIMMER	STT	75-TRIKO-02-3/9pf
C313	.47mf 20%	ERT	8131-100-651-474M	C510	10pf 10%	ASP	9213-10110
C314	.47mf 20%	ERT	8131-100-651-474M	C511	3-9pf TRIMMER	STT	75-TRIKO-02-3/9pf
C401	800mf	40V	MAL TCW801H040J1P1P	C512	10pf 10%	ASP	9213-10110
C402	1mf	20%	MAL TDC105M035EL	C513	1pf 10%	ASP	9206-10919
C403	800mf	40V	MAL TCW801H040J1P1P	C514	2pF 10%	QC	TYPE QC
C404	1mf	20%	MAL TDC105M035EL	C515	3.3pf 10%	ASP	9209-33910
C405	.047mf	20%	ERT 8121-100-651-473M	C516	2pf 10%	ASP	9209-33910
C406	1mf	20%	MAL TDC105M035EL	C517	3.9pf 10%	ASP	9209-33910
	.047mf	20%	ERT 8121-100-651-473M	C518	1pf 10%	ASP	9206-10919
	1mf	20%	MAL TDC105M034EL				
	20mf	50V	SP 30D206G050CC4				
	1mf	20%	MAL TDC105M035EL				

TRANSISTORS, DIODES, & MISC.							
Symbol	Description	Mfr.	Part No.	Symbol	Description	Mfr.	Part No.
Q101	MPS3640	MOT	MPS3640	CR403	1N4002	MSC	1N4002
Q102	T1S97	TI	T1S97	CR404	1N4002	MSC	1N4002
Q103	T1S97	TI	T1S97				
Q104	MPS6518	MOT	MPS6518	CR407	1N4149	APD	1N4149
Q201	2N4340	SIL	2N4340	CR412	1N4002	MSC	1N4002
Q202	MPS6515	MOT	MPS6515	CR413	1N4002	MSC	1N4002
Q203	MPS6515	MOT	MPS6515				
Q204	MPS3640	MOT	MPS3640	VR303	1N749A, 4.3V	APD	1N749A
Q205	MPS6518	MOT	MPS6518				
Q206	2N5189	RCA	2N5189	VR411*	1N4770A, 9.1V	C-I	1N4770A
Q207	2N5555	MOT	2N5555				
Q301	MPS6518	MOT	MPS6518	L201	FERRITE BEAD	STK	57-0181
Q302	MPS6518	MOT	MPS6518	L202	FERRITE BEAD	STK	57-0181
Q303	MPS6518	MOT	MPS6518	L203	.47uh	DLV	1537-06
Q304	MPS3640	MOT	MPS3640	L204	47uh	DLV	1537-60
Q305	MPS6566	MOT	MPS6566	L205	22uh	DLV	1537-44
Q306	2N5189	RCA	2N5189				
Q307	2N5189	RCA	2N5189	L302	3.3uh	DLV	1537-24
Q308	2N2905A	MOT	2N2905A	L304	47uh	DLV	1537-60
Q309	2N2905A	MOT	2N2905A	L306	22uh	DLV	1537-44
Q401	TIP32A	MOT	TIP32A	F401	FUSE, .3A / 115V SLOW BLOW	BUS	MDL-.3A
Q402	T1S92	TI	T1S92				
Q403	T1S93	TI	T1S93	DS401	LAMP, INDICATOR, POWER	ELD	EG03-CCB-N110
Q404	TIP31A	MOT	TIP31A				
Q405	2N5225	MOT	2N5225	J401	RECEPTACLE, POWER	SWC	EAC-301
Q406	2N5087	MOT	2N5087	S401	SWITCH, TOGGLE, POWER	CK	U11
Q407	2N5225	MOT	2N5225	S402	SWITCH, SLIDE, LINE	SWC	46256LPR
Q408	2N5087	MOT	2N5087	S501	SWITCH, MULTIPLIER	KH	6XF10-4U-GR-M
CR101	1N4149	APD	1N4149	S601	SWITCH, ATTENUATOR	KH	83697-D
CR102	1N4149	APD	1N4149				
CR103	1N4149	APD	1N4149	T401	TRANSFORMER, POWER	KH	C2883-2
CR104	1N4149	APD	1N4149				
CR105	1N4149	APD	1N4149				
CR106	1N4149	APD	1N4149				
CR301	1N4149	APD	1N4149				
CR401	1N4002	MSC	1N4002				
CR402	1N4002	MSC	1N4002				

\*VR411: - TC ~ 100ppm/°C

MANUFACTURERS CODE					
AB (01121)	Allen Bradley Co.	Milwaukee, Wisc.	KH (88865)	Krohn-Hite Corp.	Avon, Mass.
APD ( )	American Power Devices		KID ( )	Kidco, Inc.	Medford, N. J.
ASP (82142)	Airco Speer	Dubois, Pa.	MAL (37942)	P.R. Mallory & Co.	Indianapolis, Ind.
BKM (30646)	Beckman Instr. Co.	Milwaukee, Wisc.	MOT (04713)	Motorola Semiconductor	Phoenix, Az.
BUS (71400)	Bussman Mfg. Div.	St. Louis, Mo.	MSC (14552)	Micro-Semiconductor	Culver City, Calif.
CI (06751)	Components, Inc.	Biddeford, Me.	RCA (49671)	Radio Corp. of America	Harrison, N. J.
CK (09353)	C & K Components	Watertown, Mass.	SIL (17856)	Siliconix	Sunnyvale, Calif.
CODI (16352)	Computer Diode Corp.	Fairlawn, N. J.	SP (56289)	Sprague Electric Co.	North Adams, Mass.
DLV (99800)	Delevan Electronics	East Aurora, N. Y.	STK (78488)	Stackpole	St. Mary's, Pa.
ELD (03797)	Eldema Corp.	Compton, Calif.	STT ( )	Stettner-Trush	Cazanovia, N. Y.
ELM (72136)	Electromotive Mfg.	Willimantic, Conn.	SWC (82389)	Switchcraft, Inc.	Chicago, Ill.
ERT (72982)	Erie Technological	Erie, Pa.	TI (01295)	Texas Instruments, Inc.	Dallas, Texas