

---

**Apple Technician Guide**



**iMac (21.5-inch, Mid 2011)**

---

2011-05-04

---

 Apple Inc.

© 2011 Apple Inc. All rights reserved.

Under the copyright laws, this document may not be copied, in whole or in part, without the written consent of Apple.

Every effort has been made to ensure that the information in this document is accurate. Apple is not responsible for printing or clerical errors.

Apple  
1 Infinite Loop  
Cupertino, CA 95014-2084  
USA  
+ 1 408 996 1010  
[www.apple.com](http://www.apple.com)

Apple, the Apple logo, Mac, and Macintosh are trademarks of Apple Inc., registered in the U.S. and other countries.

---

# iMac (21.5-inch, Mid 2011)

## Contents

### About This Guide

#### Updates 9

Introduced 04 May 2011 9

#### Feedback 9

### Basics

#### Overview 11

Identifying Features 12

Product Configurations 12

#### Thunderbolt 13

#### Safety Precautions 14

#### Serial Number Location 15

### Troubleshooting

#### General Troubleshooting 17

Update Software & Firmware 17

Wireless Troubleshooting 17

Troubleshooting Theory 17

Hardware vs. Software 17

Common Reset Procedures 18

Power On Self Test (POST) 18

Starting Up in Safe Mode 18

Resetting the System Management Controller (SMC) 19

Resetting Parameter RAM (PRAM) 19

Coin Battery Removal, Testing, and PRAM Reset 20

Recovering a Lost Firmware Password 20

Diagnostics 21

Sensor Errors 21

Sensor and Fan Connector Locations 24

Diagnostic LEDs 25

LED Startup Sequence 26

Block Diagram 27

---

Functional Overview 28

**Symptom Charts 30**

Startup and Power 30

No Power 30

No Startup 32

Intermittent Shutdown 34

Kernel Panic / System Crashes 39

No Video 41

Corrupted Video 43

Burnt Smell/Odor 46

Uncategorized Symptoms 47

Display 48

Backlight Issue/No Backlight 48

Noise / Unstable Flickering 50

Incorrect/Missing Colors 54

Distorted/Blurred Image 55

Pixel Anomalies 57

Vertical/Horizontal Lines 58

Non-Uniform Brightness / Color 60

Cosmetic Issues 61

Uncategorized Symptoms 61

Mass Storage 62

Hard Drive or SSD Not Recognized 62

Hard Drive Read/Write Errors 64

Hard Drive Noisy 66

Optical Drive Not Recognized 68

Optical Drive Rejects or Does Not Accept Media 70

Optical Drive Read/Write Error 72

Optical Drive Not Performing to Specifications 74

Optical Drive Noisy 76

SD Memory Card Cannot Be Inserted Into Slot 78

SD Memory Card Not Recognized 79

Uncategorized Symptoms 81

Communications 82

AirPort Issues 82

Deep Dive 84

Bluetooth Issues 85

AirPort Card Kernel Panic 87

Ethernet Issues 88

Wireless Input Device Does Not Pair 90

Uncategorized Symptoms 92

Input/Output Devices 93

Apple Remote Issues 93

Distorted Audio From Internal Speaker(s) 97

No Audio From Internal Speaker(s) 98

---

Camera Issues	100
USB Port Not Recognized	103
Wired Keyboard Does Not Work Properly	105
Keyboard: Specific Keys Do Not Respond	107
Wired Keyboard/Mouse Not Recognized	107
Wireless Input Device Does Not Pair	109
Apple Wireless Mouse/Magic Trackpad Erratic Tracking	111
Wireless Input Device Loses Connection	112
Mechanical	116
Noise/Hum/Vibration	116
Fan Failures / Thermal Issues	119
Stand/Hinge Issues	121
Uncategorized Symptoms	121

## **Take Apart**

### **General Information 123**

Opening the Computer	123
Required Tools	123
Required Special Tools for Glass Panel	124
Cleaning Tools Starter Kit	124
Cleaning & Handling the Glass Panel	125
Do's and Don'ts	125
Handling a Broken Glass Panel	125
How to Remove a Broken Glass Panel	126
Safety	130
Logic Board Handling	131
Reassembly Steps	131
Note About Images in This Guide	131
Screw Sizes	131

### **Access Door 132**

### **Memory 134**

### **Glass Panel 136**

Removal	137
Reassembly	138

### **LCD Panel 141**

Handling LCD Panel	145
--------------------	-----

### **Vertical Sync (V-Sync)/ Temp Sensor Cable 147**

### **DisplayPort Cable 150**

---

DisplayPort Power Cable	152
Battery	154
AirPort Card	156
Bluetooth Board	158
Bluetooth Antenna	160
Camera	162
LED Backlight Board	165
Power Supply	167
Backlight Pressure Wall	169
Hard Disk Drive (HDD)	171
Power Supply Pressure Wall	174
Bluetooth/Camera/Sensor Cable	176
Skin Temp Sensor Cable	180
AirPort Antenna, Top Right	182
AirPort Antenna, Left Side	184
Optical Disc Drive (ODD)	186
Optical Drive Sensor Cable	189
Optical Drive Fan	191
SD Card Reader	193
SD Card Reader Cable	195
Audio Ports & Cable	197
IR Board & Cable	199
Logic Board	201
Video Card	209
Video Card Bracket	211
ODD Data/Power Cable	213
HDD Data Cable	215

---

<b>HDD Power Cable</b>	<b>217</b>
<b>DC Power Cable</b>	<b>219</b>
<b>Optical Drive Pressure Wall</b>	<b>222</b>
<b>Hard Drive Fan</b>	<b>224</b>
<b>CPU Fan</b>	<b>226</b>
<b>Left Speaker</b>	<b>229</b>
<b>Right Speaker</b>	<b>232</b>
<b>Mechanism Cover</b>	<b>234</b>
<b>Stand</b>	<b>236</b>
<b>Mechanism</b>	<b>238</b>
<b>Rear Housing</b>	<b>240</b>

## **Views**

<b>Exploded Views</b>	<b>244</b>
iMac (21.5-inch, Mid 2011), Part 1	244
iMac (21.5-inch, Mid 2011), Part 2	245
iMac (21.5-inch, Mid 2011), Part 3	246
<b>Screw Chart</b>	<b>247</b>
<b>External Views</b>	<b>249</b>
Front View	249
Rear View	250
I/O Ports	251
<b>Internal Views</b>	<b>252</b>
Components Below LCD	252
Components Below Logic Board	253
Logic Board, Front Side	254
Logic Board, Back Side	254

---

 **Apple Technician Guide**

**About This Guide**

---

**iMac (21.5-inch, Mid 2011)**

---

# Updates

Introduced 04 May 2011

## Feedback

We want your feedback to help improve this and future Technician Guides!  
Please email any comments to: [smfeedback6@apple.com](mailto:smfeedback6@apple.com)

## **Basics**

---

### **iMac (21.5-inch, Mid 2011)**



# Overview



The iMac (21.5-inch, Mid 2011) has an all-aluminum enclosure with a glass front which extends all the way to the top, left and right edges. Its external appearance is nearly identical to the previous two models, iMac (21.5-inch, Late 2009) and iMac (21.5-inch, Mid 2010), but includes new features such as Thunderbolt, a FaceTime HD camera, and an optional solid state drive.

The Mid 2011 model can be most easily distinguished from the Late 2009 and Mid 2010 models by the Thunderbolt symbol on the rear ports, the location of the battery on the front of the logic board, and the presence of a third AirPort antenna.



## Identifying Features

The iMac (21.5-inch, Mid 2011) features include:

- 21.5-inch (viewable) LED-backlit glossy widescreen TFT display with support for millions of colors; 1920 by 1080 pixel resolution
- Processor and memory:
  - 2.5GHz quad-core Intel Core i5 with 6MB on-chip shared L3 cache
  - 2.7GHz quad-core Intel Core i5 with 6MB on-chip shared L3 cache
  - 2.8GHz quad-core Intel Core i7 (CTO)
  - 4GB (two 2GB SO-DIMMs) of 1333MHz DDR3 SDRAM; four SO-DIMM slots support up to 16GB maximum
- Graphics and video support:
  - AMD Radeon HD 6750M with 512MB of GDDR5 memory
  - AMD Radeon HD 6770M with 512MB of GDDR5 memory
- One Thunderbolt port, Mini DisplayPort output with support for DVI, VGA, and dual-link DVI (adapters sold separately), four USB 2.0 ports, one FireWire 800 port, Gigabit Ethernet
- Built-in FaceTime HD 720p camera
- Hard Drive: 500GB, 1TB, or 2TB 7200-rpm Serial ATA
- Solid State Drive options (CTO):
  - 256GB SSD (SSD only, without a hard drive)
  - 256GB SSD + 1TB Serial ATA Hard Drive
  - 256GB SSD + 2TB Serial ATA Hard Drive
- SDXC (Secure Digital Extended Capacity) card slot; supports higher card capacity, 32GB-2TB
- Ships with and requires at least Mac OS 10.6.6

## Product Configurations

For product configurations, refer to AppleCare Tech Specs: <http://support.apple.com/specs/>



# Thunderbolt

Thunderbolt is a revolutionary I/O technology that supports high-resolution displays and high-performance data devices through a single, compact port. It sets new standards for speed, flexibility, and simplicity. Read more at <http://www.apple.com/thunderbolt/>



**Important:** Thunderbolt requires up-to-date software and firmware to function properly. Obtain the latest updates via Software Update.

**Caution:** The Thunderbolt port is keyed for cable insertion in only one direction. Be sure to insert cables with the correct orientation. Do not use excessive force if the cable does not fit.

**Reassembly Note:** The Thunderbolt port has a precise fit. To properly align logic board with rear housing, you **MUST** plug in cables to the Thunderbolt port and also to the furthest left USB port while tightening screws.

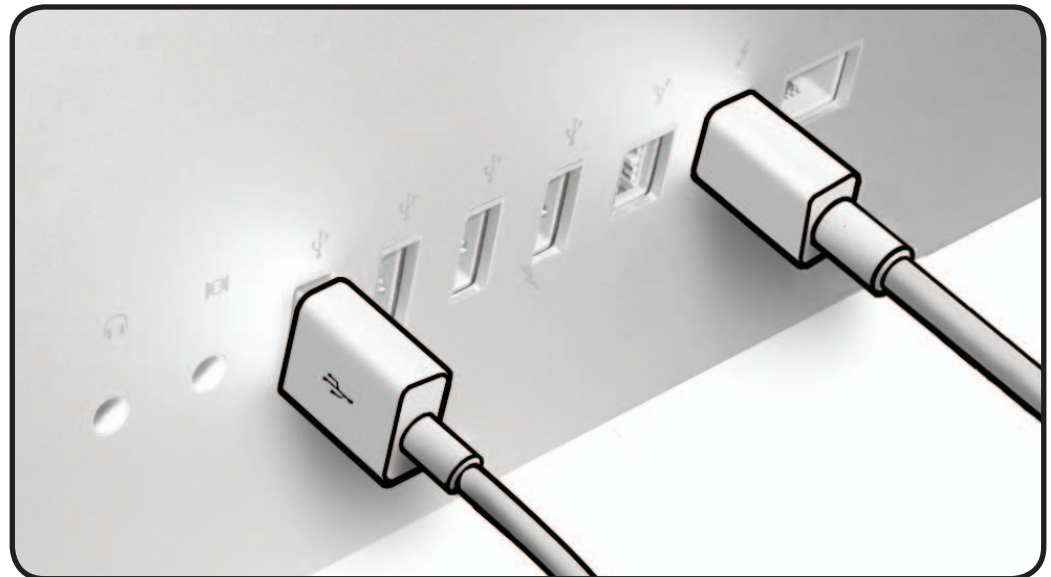



# Safety Precautions



**Warning: HIGH VOLTAGE:** The power supply remains powered up whenever computer is plugged in, whether or not computer has been turned on. Use extreme caution when troubleshooting computer with the glass panel removed.

**Important:** If computer is shut down by removing power cord, allow power supply a good 2-3 minutes to discharge capacitors before handling it. However, if you select “Shut Down” via the Apple menu, the computer will discharge power supply capacitor almost immediately.

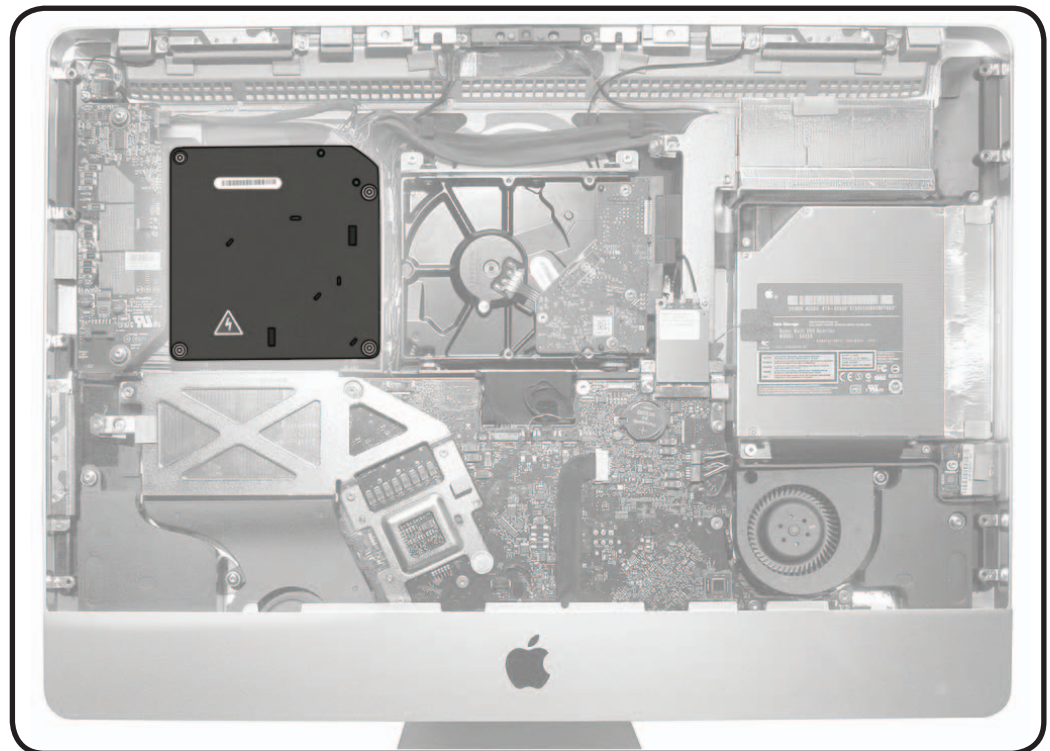



# Serial Number Location

The iMac (21.5-inch, Mid 2011)'s serial number is located on the bottom of the stand. When replacing a stand, use a fine-tip black permanent marker to neatly write the serial number on the bottom of the new stand.



## **Troubleshooting**

---

### **iMac (21.5-inch, Mid 2011)**



# General Troubleshooting



## Update Software & Firmware

**Important:** Before you begin troubleshooting, ensure the correct version of Mac OS X is installed, and check for and apply the latest software and firmware updates.

Firmware is the name given to software that is written into memory circuits such as flash memory, that will hold the software code indefinitely, even when power is removed from the hardware. Firmware on Intel Mac computers is designed to be updated if necessary by running the Mac OS X Software Update check (available in the Apple () menu) while the computer is connected to the Internet. For more information about firmware updates, refer to Apple Support article [HT1557: About firmware updates for Intel-based Macs](#).

## Wireless Troubleshooting

For Bluetooth and wireless connectivity issues, refer to the following Apple Support articles:

- [TS3048: Troubleshooting wireless mouse and keyboard issues](#)
- [HT3887: Wireless input devices: Bluetooth frequently asked questions](#)
- [HT1365: AirPort and Bluetooth: Potential sources of interference for wireless devices and networks](#)
- [HT3903: Apple Wireless Keyboard, Mouse, and Trackpad: How to install batteries](#)
- [Bluetooth Service Diagnostic \(BSD\) self-paced training](#)
- [Bluetooth Troubleshooting Course](#)

## Troubleshooting Theory

For general information on troubleshooting theory, go to GSX and find the Service Training course menu link. From there you can access the Troubleshooting Theory self-paced course.

## Hardware vs. Software

For information on how to isolate a hardware issue from a software issue, refer to Apple Support article [TS1388: Isolating issues in Mac OS X](#)

For information on how to troubleshoot a software issue, refer to the following Apple Support articles:

[HT1199: Mac OS X: How to troubleshoot a software issue](#)

[TS1394: Mac OS X: Troubleshooting installation and software updates](#)

[HT2956: Troubleshooting Mac OS X installation from CD or DVD](#)



## Common Reset Procedures

### Power On Self Test (POST)

Intel-based Mac computers such as the iMac rely on a combination of tones and blinking LEDs to display Power On Self Test (POST) error codes.

- If the computer detects out-of-specification or no SDRAM, the screen will remain black but the computer will beep. This error condition may be due to physically damaged RAM, installing an incorrect type of RAM, or not having RAM installed.
- Some RAM may appear to pass the Power-On-Self-Test (POST) but still cannot be used by the operating system. In this case, the computer will display a gray screen, sound three tones and repeat tones until computer is turned off.
- The solution to both of these situations is to first re-seat memory and test computer again. If memory fails POST again, remove all installed memory and test by installing one by one each memory module that has been verified to work correctly on another computer (i.e., “known-good” memory) or order new memory.
- A sequence of tones heard at startup or a no video symptom may also be fixed by temporarily removing/replacing the backup battery.

For more information, refer to Apple Support article

[HT2538: iMac \(Mid 2007\) and later models: About new startup tones](#)

### Starting Up in Safe Mode

A Safe Boot is a special way to start Mac OS X when troubleshooting. Starting up into Safe Mode does several things that can help resolve software or directory issues that may exist on the startup volume. To start up in Safe Mode:

1. Make sure computer is shut down.
2. Press power button.
3. Immediately after you hear the startup tone, press and hold Shift key.  
**Note:** The Shift key should be held as soon as possible after startup tone but not before.
4. Release Shift key when you see the screen with the gray Apple and progress indicator (looks like a spinning gear). Note that booting into Safe Mode will take longer than a normal startup. During startup, the words “Safe Boot” appear on the Mac OS X startup screen and a gray progress bar is displayed on bottom of window (since Mac OS X 10.6).
5. To leave Safe Mode, restart computer normally, without holding down any keys during startup.

For more information, refer to the following Apple Support articles:

[HT1564: Mac OS X: What is Safe Boot, Safe Mode?](#)

[TS1884: Safe Boot takes longer than normal startup](#)



## Resetting the System Management Controller (SMC)

The System Management Controller (SMC) is a chip on logic board that controls all power functions. If computer is experiencing any power issue, such as not starting up, not displaying video, sleep issues, or fan noise issues, resetting SMC may resolve it. To reset SMC on an iMac:

6. From Apple menu, choose Shut Down (or if the computer is not responding, hold power button for approximately ten seconds until it powers off).
7. Unplug all cables from computer, including power cord.
8. Press and hold the power button for 5 seconds.
9. Release the power button.
10. Attach the computer's power cable, making sure power button is not being pressed.  
**Note:** If you press the power button while inserting the power cord, the iMac will enter a mode in which the fans run at full speed. For more information, refer to Apple Support article [TS1433: iMac: Fans run at full speed after computer turns on](#)
11. Press the power button to turn on the computer.

For more information, refer to Apple Support article

[HT3964: Intel-based Macs: Resetting the System Management Controller \(SMC\)](#)

## Resetting Parameter RAM (PRAM)

PRAM stores certain system and device settings in a location that Mac OS X can access quickly. Exactly which settings are stored in the computer's PRAM varies depending on the type of computer as well as the types of devices and drives connected. To reset PRAM:

1. Shut down the computer.
2. Locate the following keys on keyboard: Command, Option (Alt), P, and R. You will need to hold these keys down simultaneously in Step 4.
3. Press power button.
4. Immediately press and hold Command-Option-P-R keys.  
**Important:** You must press this key combination before the gray screen appears.
5. Hold down keys until the computer restarts, and you hear the startup chime a second time.
6. Release keys.

For more information, refer to the following Apple Support articles:

[HT1242: Mac OS X: What's stored in PRAM](#)

[HT1379: Resetting your Mac's PRAM and NVRAM](#)



## Coin Battery Removal, Testing, and PRAM Reset

1. Shut down and unplug the computer. Allow several minutes for power supply to discharge.
2. The coin battery is located on the front side of the logic board (see graphic below) and provides power for the battery-backed RAM and clock. In order to reset the PRAM, remove the coin battery for 1-2 minutes.

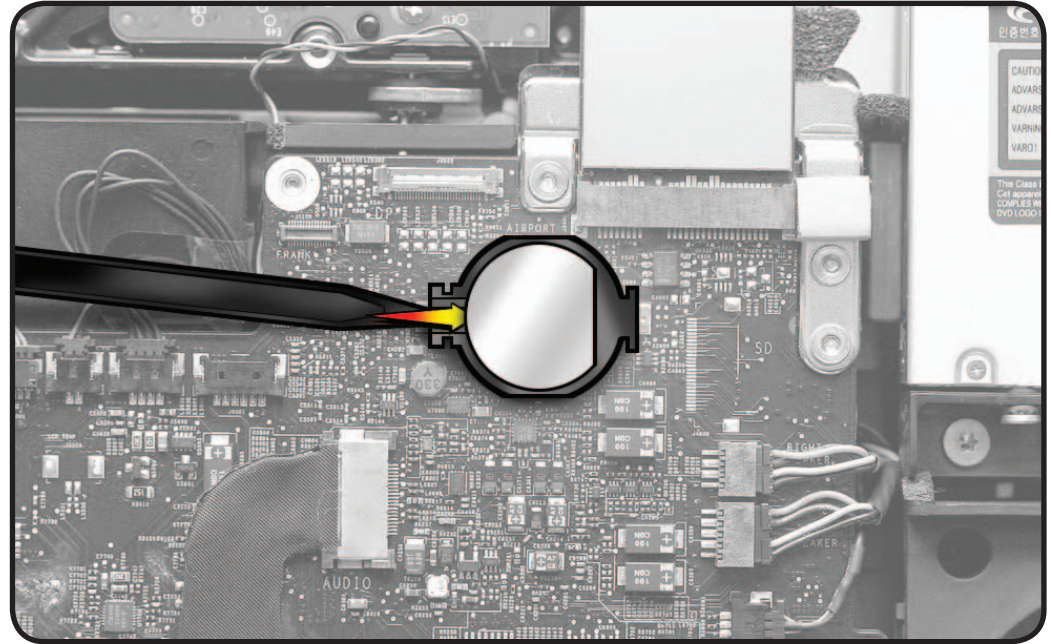

3. Measure DC voltage on battery touching battery with red probe, and grounding with black probe. If voltage is 2.7v or less, replace battery.
4. Reinstall battery and reassemble computer.
5. Power on computer.
6. If computer starts up successfully, check for and apply the latest software and firmware updates.

## Recovering a Lost Firmware Password

Only Apple Retail Stores or Apple Authorized Service Providers can unlock an iMac (21.5-inch, Mid 2011) protected by a firmware password.

Refer to Apple Support article [TS3554: Recovering a lost firmware password.](#)



## Diagnostics

The following diagnostics are required for this product:

- Apple Service Diagnostic (ASD), version **3S145**
- Apple Hardware Test (AHT), version **3A212**

**Note:** Install DVD silkscreen reads AHT version 3A214.

**Note:** Follow instructions in “Read Me” file that accompanies any diagnostic. Failure to run diagnostics as instructed can lead to false error codes.

## Sensor Errors

Run the latest Apple service diagnostics to determine if any thermal sensors or fans are malfunctioning. When a test reports an error, reseal appropriate connections and check that all air flows are free from obstruction. If issue persists, replace the corresponding part (sensor, fan, logic board, video card, or power supply). See chart below for correlation between affected sensor, sensor location, and additional checks to perform.

**Note:** AHT can be run by pressing the D key on startup (if hard drive was not reformatted, or if adequate model-specific restore DVD is inserted). If a sensor error is detected, AHT will report an error code containing the affected sensor name (e.g., “4SNS/1/40000000 TC0H” error code reports to sensor TC0H).

Sensor	Suspected Part/Location	Suggested Action	Notes
TA0p	Excessive incoming ambient air temperature, or ambient temp sensor (part of CPU fan assembly) is damaged/disconnected from logic board.	Verify that incoming/outgoing air vents are free from obstruction, and that CPU fan cable is securely connected to the left edge of the logic board. Replace fan/sensor assembly if damaged.	All fans ramp at full speed if fan/sensor is disconnected.
TC0H	Excessive processor heatsink temperature.	Check CPU heat sink sensor cable connection to logic board. It is located on back side and requires removal of the logic board.	If the sensor is disconnected, the CPU fan will run at full speed.
TC0p TC0c TC1c TC2c TC3c TCGc TCSc TCXc	Excessive logic board temperature (these sensors are part of logic board).	Test with known-good logic board.	
TG0D	Excessive graphics processor die temperature (sensor is part of graphics processor chip)	Test with known-good video card.	



Sensor	Suspected Part/Location	Suggested Action	Notes
<b>TG0H</b>	Excessive graphics processor heat sink temperature, or GPU temp sensor damaged/ disconnected from back side of logic board (this sensor is part of video card assembly)	Check GPU sensor cable connection to logic board. (requires removal of the logic board to access).	If sensor is disconnected the ODD fan will run at full speed.
<b>TH0O</b>	Excessive hard drive area temperature (sensor is part of HDD)	Verify HDD power cable is securely connected to logic board, and is correctly connected and oriented to the hard drive end. Check for damaged cable or logic board.	The HDD fan may run at full speed if HDD power cable is disconnected/ misconnected.
<b>TL0p</b>	Excessive LCD panel area temperature	Verify that the DisplayPort cable is securely connected to both the LCD panel and the logic board.	
<b>Tm0p</b>	Excessive logic board temperature (this sensor is part of logic board)	Test with known-good logic board.	
<b>TO0P</b>	Excessive optical drive area temperature, or ODD temp sensor damaged/ disconnected from logic board.	Verify ODD temp sensor cable is securely connected to the logic board and the sensor is properly attached to the ODD. Replace sensor cable if damaged.	The ODD fan will run at full speed if sensor is disconnected.
<b>Tp1P</b> <b>Tp2H</b> <b>Tp3H</b>	Excessive power supply temperature (these sensors are part of the power supply)	Test with known-good DC power cable, or known-good power supply.	
<b>TS0p</b>	Excessive upper internal enclosure temperature, or skin temp sensor damaged/ disconnected from top of logic board.	Verify that the skin temp sensor cable is securely connected to the top of the logic board. Replace the cable if damaged.	sensor located to right of camera
<b>TS2p</b>	Excessive upper internal enclosure temperature, or Bluetooth/camera/ sensor cable damaged/ disconnected from top of logic board.	Verify that the Bluetooth/camera/ sensor cable is securely connected to the top of the logic board. Replace the cable if damaged.	sensor located to left of camera
<b>ODD fan</b>	Optical fan located next to right speaker	Verify that the ODD fan cable is securely connected to the right side of the logic board and that there are no obstructions that would prevent the fan from rotating. Replace fan if error continues.	Normal fan operation, except the ODD fan.



Sensor	Suspected Part/Location	Suggested Action	Notes
<b>HDD fan</b>	Hard drive fan, located below logic board, near hard drive.	Verify that the HDD fan cable is securely connected to the top of the logic board and that there are no obstructions that would prevent the fan from rotating. Replace fan if the error continues.	Normal fan operation, except the HDD fan.
<b>CPU fan</b>	CPU fan, located next to left speaker.	Verify that CPU fan cable is securely connected to the left side of the logic board and that there are no obstructions that would prevent the fan from rotating. Replace fan if the error persists.	Normal fan operation, except the CPU fan.



## Sensor and Fan Connector Locations

Thermal sensors and fan connector locations are shown below. Ensure cables are correctly routed and the sensors and fans are properly connected. If a sensor or fan is faulty or not connected, diagnostics will generate an error code.

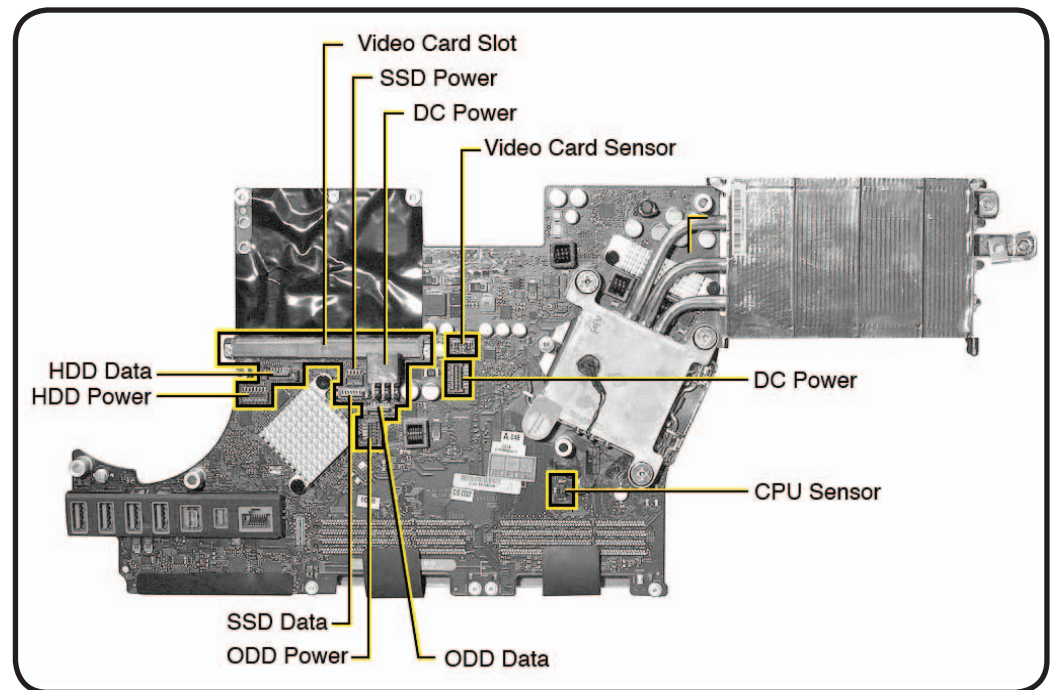
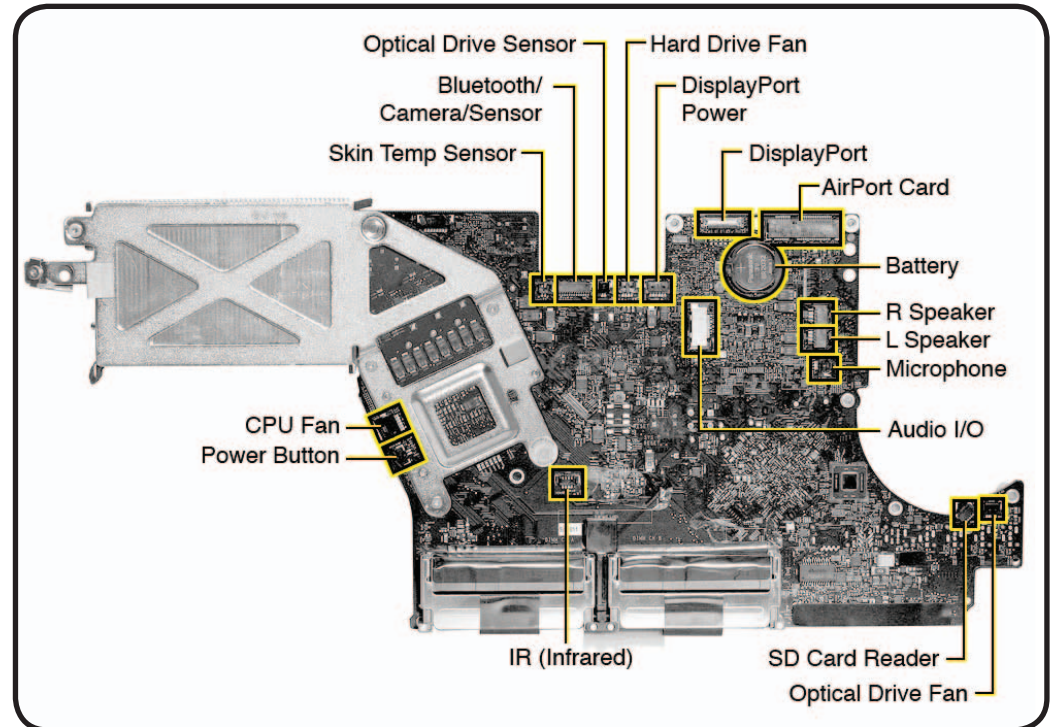



## Diagnostic LEDs

There are four diagnostic LEDs on the front center of the logic board that can help troubleshoot the computer. **Note:** The audio cable covers the diagnostic LEDs, so you will need to disconnect or reposition the audio cable in order to view the LEDs.

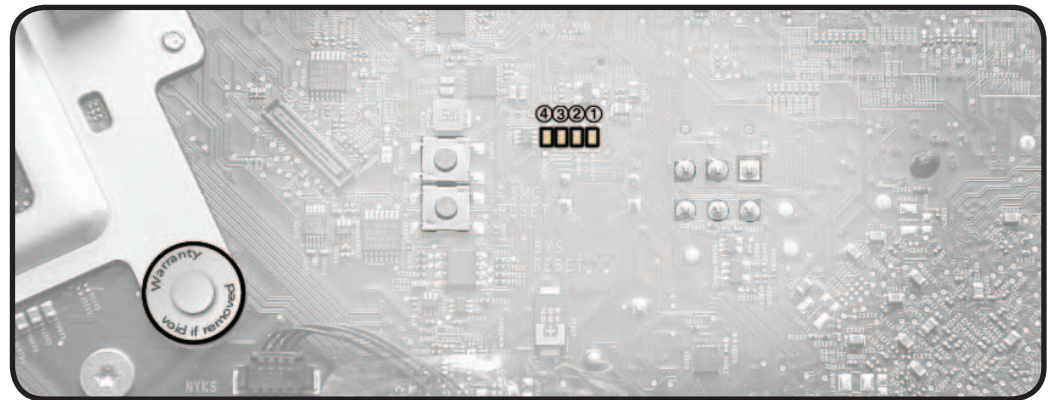

### LED Functions

#### LED #1

Indicates that the trickle voltage from power supply has been detected by main logic board. This LED will turn ON when you connect the iMac to a working AC power source. The LED will remain ON as long as the computer is ON or asleep.

When computer has been correctly shut down, the LED#1 behavior may differ:

- - If a startup event is scheduled in System Preferences > Energy Saver, LED#1 will stay ON after a correct shutdown,
- - If no startup event is scheduled in System Preferences > Energy Saver, LED#1 will turn OFF and will stay OFF as long as power cord is connected and AC power source is present. Disconnecting the power cord and plugging it back will turn back this LED ON, even if computer is still off.
- After disconnecting and reconnecting the AC power source, this LED could remain OFF if the AC power source is missing or disconnected, if the logic board is disconnected from the power supply or from the AC outlet, or if the power supply board is faulty.

#### LED #2

Indicates that computer is turned on. This LED will be ON as long as computer is turned on (but is not asleep) and power supply and voltage regulators are working correctly.

#### LED #3

Indicates that computer and video card are communicating. This LED will be ON when computer is communicating properly with video card. If LEDs 1 and 2 are ON and you heard the startup sound, but LED 3 is OFF, then the backup battery (on front of logic board) may need to be reseated, or the video card might be installed incorrectly or needs replacement.



## LED #4

Indicates that computer and LCD panel are communicating. This LED will be ON when computer is turned on and video signal is being generated. If LED #4 is ON and there is no image on display, then LCD panel, LED backlight board, or cables between LCD and logic board or backlight board might be installed incorrectly, or need replacement.

## LED Startup Sequence

### LED #1 = Power available.

If first LED is not lit:

- Disconnect the power cord from computer, then reconnect it to reset the LED status.
- Verify AC power source.
- Verify known-good power cord is connected.
- Verify cable connection between AC inlet and power supply.
- Verify cable connection between power supply and logic board.
- Verify power supply.

### LED #1 + #2 = Power available, and computer is powered on.

If second LED is not lit when power button is pressed:

- Verify power button cable connection to logic board.
- Verify power button functionality.
- Verify cable connection between power supply and logic board.
- Verify power supply.
- Verify logic board.

### LED #1 + #2 + #3 = Power available, computer is powered on, and video card found.

If third LED is not lit after power on:

- Verify that video card is seated properly.
- Verify if startup sound is present and fans are running when powered ON (reset SMC and PRAM, reseal or check backup battery if necessary for proper startup):
  - If POST startup sound is not heard, go to [No Startup](#) symptom flow,
  - If POST startup sound is heard, go to [No Video](#) symptom flow.

### LED #1 + #2 + #3 + #4 = Power available, computer is powered on, video card found, and internal LCD found.

If fourth LED is not lit after power on:

- Verify internal DisplayPort cable connections between LCD panel and logic board.
- Inspect all LCD cables for damage.
- Verify external video functionality, and according to result check the following items:
  - If external display works then verify/replace the LED backlight board.
  - If external display works then verify/replace the LCD panel.
  - If external display does not work verify/replace the logic board.



## Block Diagram

Refer to this diagram to see how modules are interrelated.

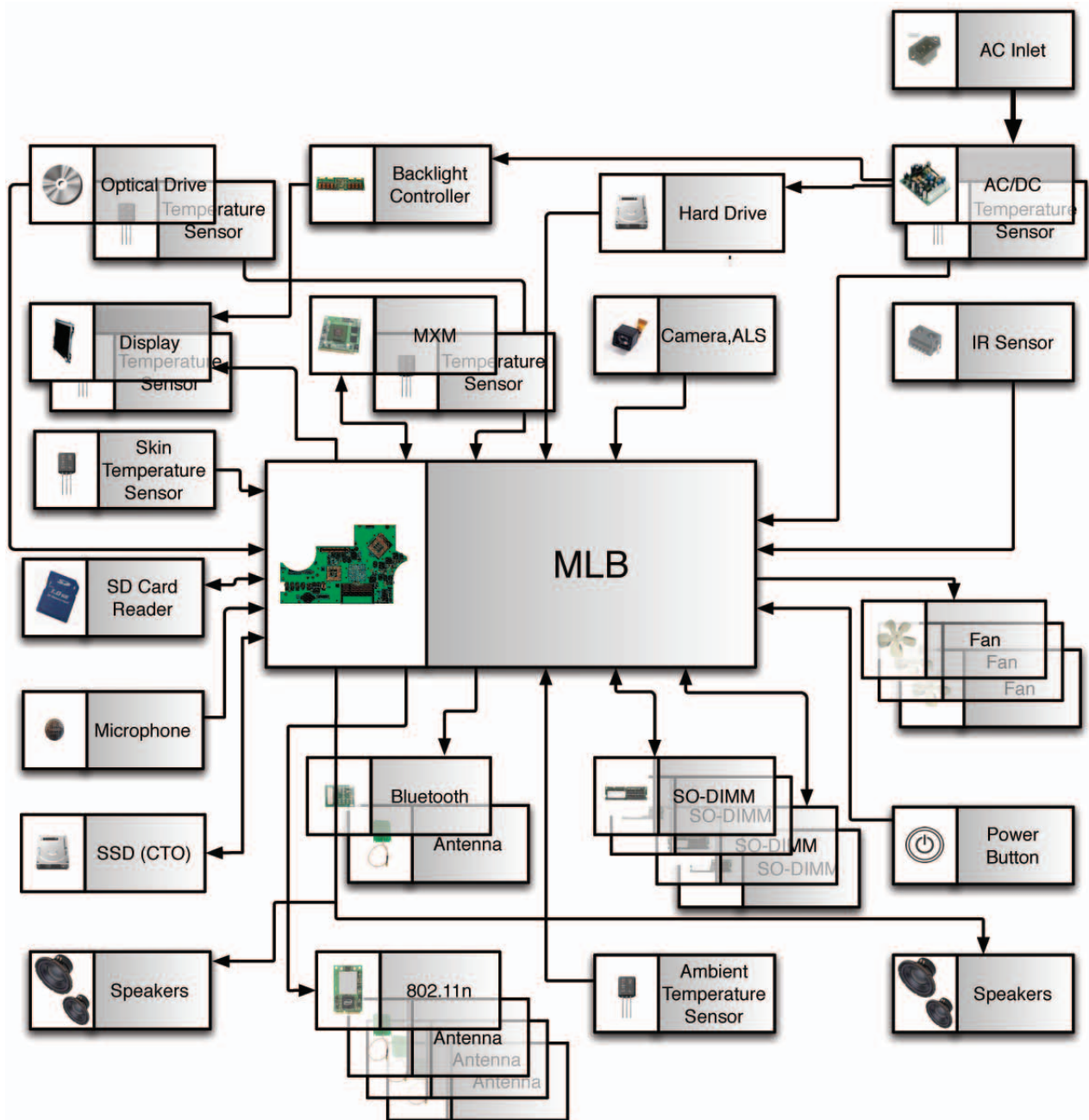



## Functional Overview

Refer to this diagram for symptoms related to connectors on the front of the logic board.

*To rotate this page in Preview for easier viewing, go to Tools menu and choose "Rotate Left"*

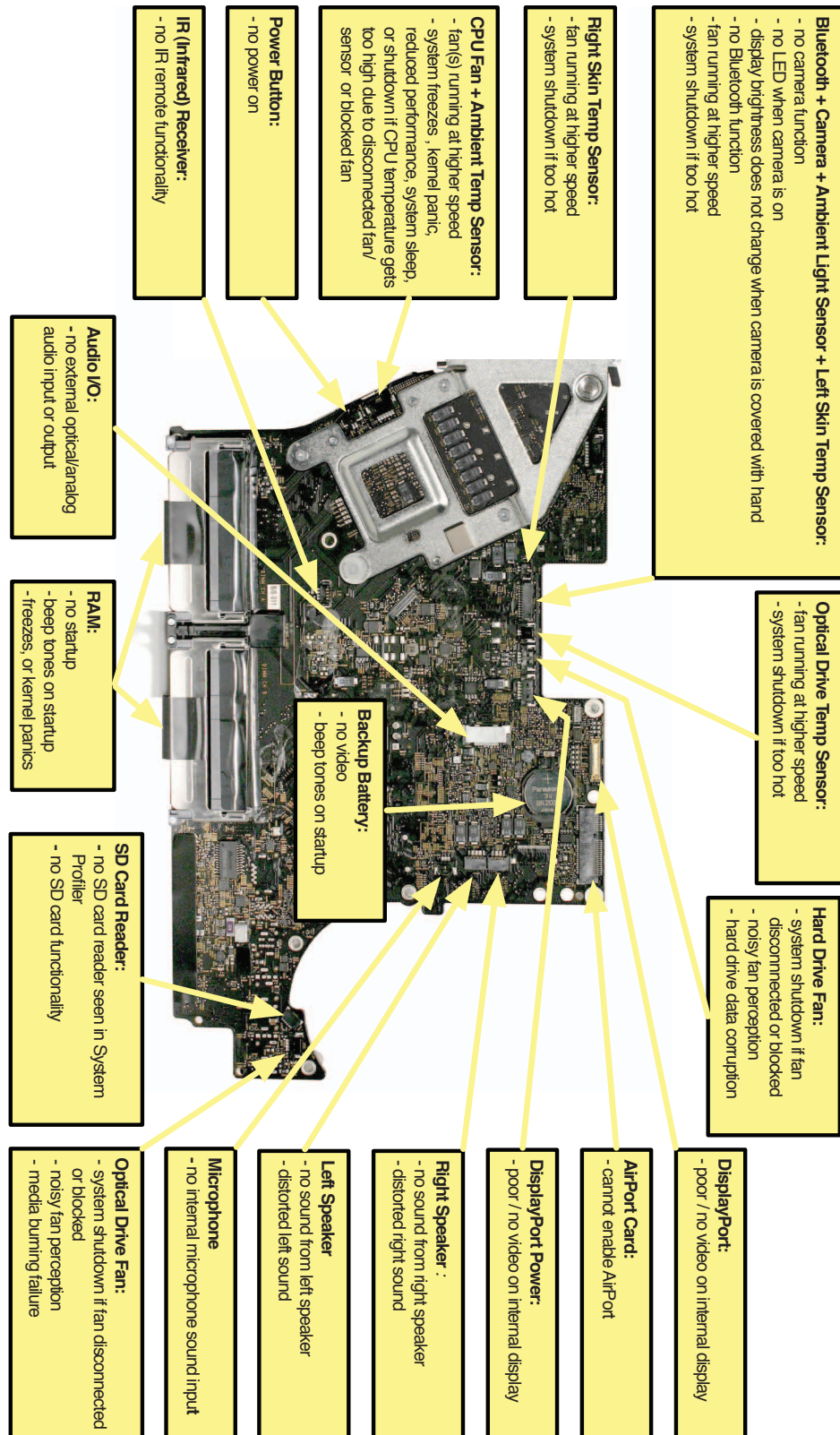



Refer to this diagram for symptoms related to connectors on the back side of logic board.  
*To rotate this page in Preview for easier viewing, go to Tools menu and choose "Rotate Left".*

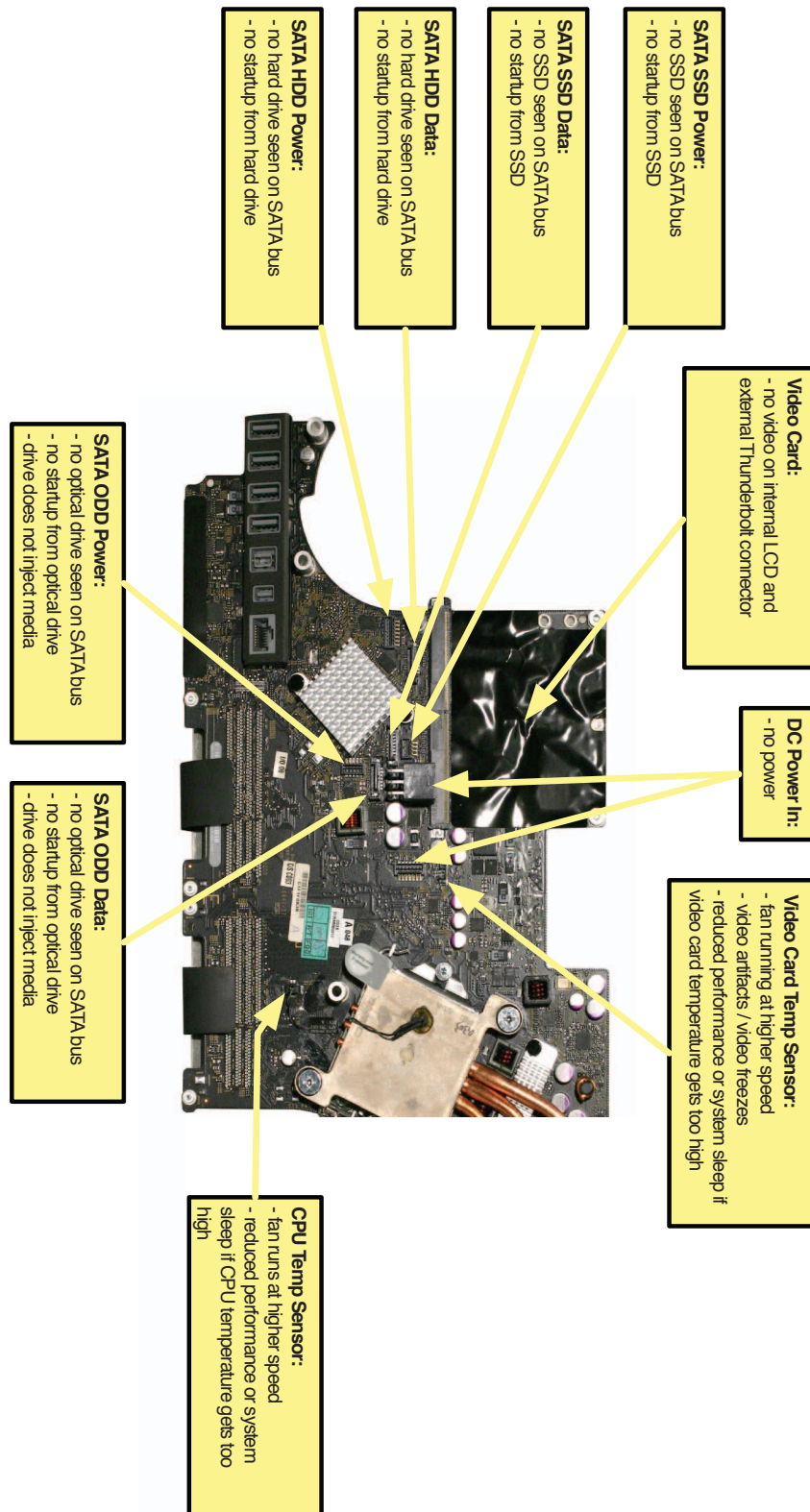



# Symptom Charts

Follow steps in the order indicated below. If an action resolves the issue, retest system to verify.

## Startup and Power

### No Power

Unlikely cause: speakers

#### Quick Check

Symptoms	Quick Check
<b>No Power</b> <ul style="list-style-type: none"> <li>No power</li> <li>No fan spin</li> <li>No startup sound</li> <li>No image on external display</li> <li>No hard drive or optical drive activity</li> <li>Caps Lock LED on wired keyboard doesn't light when pressed.</li> </ul>	<ol style="list-style-type: none"> <li>Verify power source.</li> <li>Verify power cord.</li> <li>Listen closely for signs of activity from system including: rotating fans, hard drive or optical drive activity, startup sound, etc.</li> <li>Disconnect all peripherals.</li> <li>Reset SMC: shut down computer, unplug power cord, press and hold power button for 5 seconds, release power button, and reconnect power cord.</li> </ol>

#### Deep Dive

Check	Result	Action	Code
1. Attempt normal startup. Press power button to start up computer. Does the computer exhibit any signs of power activity, such as fan or hard drive activity, startup sound or Caps Lock LED on wired keyboard?	Yes	Go to step 2.	
	No	Go to step 4.	
2. Verify display functionality. Confirm whether a video signal appears on the display. Is a video image clearly visible on the display?	Yes	Run Mac Resource Inspector (MRI) to obtain latest test results. Redirect to appropriate symptom.	
	No	Go to step 3.	



3. Verify video without backlight. On a display with dim or no backlight, shine an LED flashlight through the glass on the front of the display to check for video signal. Is any video visible with flashlight?	Yes	Go to <a href="#">Backlight Issue / No Backlight</a> symptom flow.	
	No	Go to <a href="#">No Video</a> symptom flow.	
4. Disconnect power cord. Carefully inspect the connectors between AC inlet and power supply, then DC connectors and cables between power supply and logic board, for damage or poor connections.	Yes	Reseat misconnected cable(s), or replace damaged one(s).	<b>P16</b>
	No	Replace DC power cable. Go to step 8.	<b>X03</b>
5. Inspect power button and verify if it is properly connected to the logic board.	Yes	Go to step 6.	
	No	Reconnect power button.	
6. Disconnect power button from logic board. Inspect cable and connector for damage. Using a multimeter (set as ohmmeter), verify continuity between the two pins of the power button when it is pressed.	Yes	Power button is functioning correctly. Reconnect power button to logic board and go to step 7.	
	No	Power button faulty. Replace rear housing (which includes power button).	<b>X14</b>
7. Reconnect power cord. Press power button and verify if system turns ON. You may alternately check for diagnostic LED #2 to illuminate when the power button is pressed. See <a href="#">Diagnostic LEDs</a> section for more information.	Yes	Power supply functioning. If computer still won't boot, go to <a href="#">No Startup</a> .	
	No	Replace DC power cable. Go to step 8.	<b>X03</b>
8. Press power button and verify if computer turns ON.	Yes	Issue solved with replaced DC power cable.	
	No	Replace power supply. Go to step 9.	<b>P01</b>
9. Press power button and verify if computer turns ON.	Yes	Issue solved with replaced power supply.	
	No	Reinstall power supply and replace logic board.	<b>M01</b>

Note: If No Power symptom persists after all steps have been followed use minimum configuration troubleshooting to proceed. Try disconnecting hard drive, optical drive, AirPort card, SD card reader and Bluetooth/camera/sensor cable to determine if one of them is preventing the power supply from functioning.



## No Startup

### Quick Check

Symptoms	Quick Check
<p><b>No Startup</b></p> <ul style="list-style-type: none"> <li>• No startup sound or POST (Power On Self-Test)</li> <li>• Gray screen appears during startup</li> <li>• Some video activity, Apple logo, spinning gear</li> <li>• Prohibitory sign or folder with a flashing question mark</li> <li>• Startup chime or error beep tones</li> <li>• Audible fan, hard drive spin or optical drive reset sounds</li> <li>• Sleep LED on, blinking or went out.</li> <li>• Caps Lock LED on wired keyboard toggles on and off when pressed</li> </ul>	<ol style="list-style-type: none"> <li>1. Verify that the startup process passes initial memory checks and POST (Power On Self-Test) with a normal startup sound—but no beeping sounds—with some video activity.  If computer generates beeping sounds there may be an issue with the memory. See Apple Support article <a href="#">HT2341: Intel-based Mac Power On Self Test RAM error codes</a>.</li> <li>2. Disconnect all external peripherals and Ethernet cables.</li> <li>3. Reset SMC: shut down computer, unplug power cord, press and hold power button for 5 seconds, release power button, and reconnect power cord.</li> <li>4. Reset PRAM by holding down Command-Option-P-R keys while restarting, until you hear the startup sound for the second time.</li> <li>5. Start up from a known-good original system media or an up-to-date, bootable Mac OS X volume.</li> <li>6. Run Disk Utility or check Mac Resource Inspector (MRI) results to verify presence and SMART status of user's hard drive.</li> <li>7. Check the Mac OS X version and build, and refer to Apple Support article <a href="#">HT1159: Mac OS X versions (builds) included with Intel-based Macs</a> to make sure system build is the correct version for this computer model.</li> <li>8. Hold Shift key during startup to put computer into Safe Mode. See Apple Support article <a href="#">HT1564: Mac OS X: What is Safe Boot, Safe Mode?</a></li> <li>9. Identifying when in the startup process the computer hangs can help isolate the issue. See Apple Support article <a href="#">HT2674: Intel-based Mac: Startup sequence and error codes, symbols</a> for information on the Macintosh startup sequence, and error codes and symbols used.</li> </ol>



## Deep Dive

Check	Result	Action	Code
1. Verify whether computer will start up to Apple Hardware Test (AHT).	Yes	Run the extended tests and proceed with results. If AHT passes or boots with a memory error, go to step 2.	
	No	Go to step 2.	
2. Remove installed memory, and test with known-good memory. Verify whether computer starts up properly now.	Yes	Memory issue. Reinstall one of user's memory modules and retest. Proceed one by one to find the faulty memory module, and replace it.	<b>X02</b>
	No	Go to step 3.	
3. Wait 15 seconds after computer powers down, then disconnect AirPort card from logic board. Verify whether computer starts up properly now.	Yes	Go to <a href="#">AirPort Card Kernel Panic</a> .	
	No	Go to step 4.	
4. Verify whether computer will start up properly from known-good original system media or an up-to-date, bootable Mac OS X volume.	Yes	Go to <a href="#">Hard Drive or SSD Not Recognized</a> .	
	No	Go to step 5.	
5. Remove hard drive. Verify whether computer will start up properly from known-good original system media or an up-to-date, bootable Mac OS X volume.	Yes	Replace hard drive.	<b>H01</b>
	No	Go to step 6.	
6. Disconnect optical drive cable and retest. Verify whether computer starts up properly now.	Yes	Reconnect optical drive and go to <a href="#">Optical Drive Not Recognized</a> .	
	No	Go to step 7.	
7. Remove coin battery on front of logic board and leave out for approximately 1 minute. Then reinstall battery. This will reset logic board. Verify whether computer starts up properly now.	Yes	Issue resolved by logic board reset. Measure DC voltage on battery touching battery with red probe, and grounding with black probe. If voltage is 2.7v or less, replace battery.  See Apple Support article <a href="#">HT3250: Diagnostics: Using a digital multimeter</a> .	
	No	Replace logic board.	<b>M02</b>



## Intermittent Shutdown

### Troubleshooting Shutdown Causes

Always run the latest Apple service diagnostics to check for any abnormal value reading from a thermal, a voltage, or a current sensor, or from a fan speed meter. The log files may also report the cause of a previous shutdown(s).

Collect all available info from user on shutdown occurrence details: periodicity, power state when issue happens, running applications, running time before shutdown.

### Shutdown events can be categorized into four different areas.

#### 1) User-related shut downs:

A computer shutdown event may be caused by user operation. The following shutdown methods should not be considered as a failure, unless the power button is found to be defective.

- Choosing “Shut Down” from the Apple () menu.
- Pressing and holding the power button for 10 seconds.
- Programming a timed shutdown in System Preferences > Energy Saver.

Suggested troubleshooting steps are:

- Reset SMC: shut down computer, unplug power cord, press and hold power button for 5 seconds, release power button, and reconnect power cord.
- Check System Preferences > Energy Saver settings.
- Test the power button for an intermittent short that would force computer to shutdown.

#### 2) Activity-related shutdowns:

- Computer could not complete the standard shutdown process and had to force shutdown.
- An installed watchdog detected that an application did not respond within specified time (this watchdog can be enabled in Mac OS X Server Energy Saver preferences).

These shutdowns may be linked to system preferences, device drivers, applications, or operating system freezes.

Suggested troubleshooting steps are:

- Check the system logs and Activity Monitor for clues on the freezing process.
- Check for and apply the latest software and firmware updates for installed device drivers, applications, or operating system.
- Start up from known-good original system media or an up-to-date, bootable Mac OS X volume.



### 3) Power-related shutdowns:

- External power source was removed.

Power-related shutdowns are due to power management, poor connections, or defective power sources.

Suggested steps for troubleshooting are :

- Reset SMC: shut down computer, unplug power cord, press and hold power button for 5 seconds, release power button, and reconnect power cord.
- Verify the following cables are securely connected: external power cord, AC inlet, and internal DC power cable.

### 4) Hardware-related shutdowns:

- One of the thermal sensors reached a specified temperature limit.
- One of the voltage sensors reached a specified voltage limit.
- One of the current sensors reached a specified current limit.

These shutdowns are due to temperature, voltage, current, fan speed or other hardware-related sensor values getting out of range.

Suggested steps for troubleshooting are:

- Check for all sensors connections and values using the latest Apple service diagnostics and locate sensors using the table in the General Troubleshooting chapter.
- Check /listen for fan(s) operation.
- Check cleanliness of the heat sink fins and the air flow.

For additional information, continue to Quick Checks on the next page.



## Quick Check

Symptoms	Quick Check
<p><b>Intermittent Shutdown</b></p> <ul style="list-style-type: none"><li>• Shuts down during startup</li><li>• Shuts down unexpectedly during use</li><li>• Restarts spontaneously</li><li>• Shuts down when waking from sleep</li></ul>	<ol style="list-style-type: none"><li>1. Collect details from the user regarding shutdown occurrence and system configuration: when it happens (e.g., after running for a while); frequency of shutdowns; which applications are running; and shutdown repeatability. If shutdown can be easily reproduced, check next steps.</li><li>2. Make sure that power cord is securely attached to the back of computer, and is not hindered by a desk or other furniture.</li><li>3. Plug computer directly into an AC outlet to test if a surge protector or UPS is causing issue.</li><li>4. Open System Preferences &gt; Energy Saver &gt; Schedule and make sure that a “Shut Down” event is not scheduled.</li><li>5. Hold Shift key during startup to put computer into Safe Mode. See Apple Support article <a href="#">HT1564: Mac OS X: What is Safe Boot, Safe Mode?</a></li><li>6. Start up from known-good original system media or an up-to-date, bootable Mac OS X volume.</li><li>7. Run Mac Resource Inspector (MRI) to check fan (motor) and thermal sensors detection and values.</li><li>8. Reset SMC: shut down computer, unplug power cord, press and hold power button for 5 seconds, release power button, and reconnect power cord.</li><li>9. Reset PRAM by holding down Command-Option-P-R keys while restarting, until you hear the startup sound for the second time.</li><li>10. Run Apple Service Diagnostic (ASD) for looping extended sensors + thermal tests.</li></ol>



## Deep Dive

Check	Result	Action	Code
1. Activity related shutdowns: Reset SMC and PRAM and verify that shutdown issue still happens.	Yes	Check with known-good bootable drive. Go to step 2.	
	No	Shutdown cause was related to SMC or PRAM programmed shutdown settings or corruption, and was resolved by reverting them to default settings.	
2. Start up from a known-good original system media or an up-to-date, bootable Mac OS X volume, and verify whether shutdown issue still happens.	Yes	Go to step 3.	
	No	Reinstall OS on user's drive. Check for and apply the latest software and firmware updates.	
3. Power related shutdowns: With known-good AC power cord and AC outlet, verify if computer continues to restart or shutdown	Yes	Go to step 4.	
	No	AC power cord / outlet issue. Issue resolved.	<b>X03</b>
4. Disconnect hard drive power cable from hard drive and startup computer from a known-good original system media or an up-to-date, bootable Mac OS X volume. Verify whether computer continues to restart or shutdown.	Yes	Go to step 5.	
	No	Possible bad software or hard drive. Go to <a href="#">Hard Drive or SSD Not Recognized</a> .	
5. Inspect and reseal AC inlet connection to power supply (the smaller of the 2 cables connected to power supply), and DC power cable from power supply to logic board. Verify whether damage is observed on the cables or connectors.	Yes	Replace damaged cable. Retest. Return to step 1 if problem continues.	<b>X03</b>
	No	Go to step 6.	
6. Install known-good power supply. Verify whether computer continues to restart or shutdown.	Yes	Reinstall original power supply. Go to step 7.	
	No	Issue resolved with power supply replacement.	<b>P02</b>



7. Replace DC power cable, which supplies power to logic board, hard drive, and LED backlight board. Verify whether computer continues to restart or shutdown.	Yes	Go to step 8.	
	No	Issue resolved with DC power cable replacement.	<b>X03</b>
8. Hardware-related shutdowns: Run latest available Apple service diagnostics and verify if a sensor failure is reported.	Yes	-If a temperature or a fan sensor failure is reported, go to step 9.  -If a voltage or a current sensor failure is reported test with known-good power supply board. If issue persists, replace logic board.	<b>M23</b>
	No	Setup ASD's looping tests and go to step 9. If no failure is found, return computer to user for no failure found.	
9. Verify whether a thermal sensor or fan failure is reported by diagnostics.	Yes	-If fan not running failure, check for fan cable seating and retest. If same failure after retest replace fan with known-good fan and retest. If issue does not happen with known-good fan, replace user's fan.  -If an over temp failure reported, check for cause of over temp, like obstructed vent, dust in heat sink fin, clogged fan and retest. If still failing replace part where sensor is located (logic board, power supply, hard drive or sensor cable) according to the sensor location table in General Troubleshooting chapter. Go to step 10.	<b>X22</b>  <b>M23</b> <b>P17</b> <b>X03</b>
	No	Go to step 10.	
10. Isolate if issue solved Verify whether shutdown/issue does is fixed.	Yes	Issue resolved.	
	No	Replace logic board with corresponding symptom: -if for thermal error cause -if for other cause	<b>M18</b> <b>M08</b>



## Kernel Panic / System Crashes

### Quick Check

Symptoms	Quick Check
<p><b>Kernel Panic / System Crashes</b></p> <ul style="list-style-type: none"> <li>Computer displays a kernel panic alert message See Apple Support article <a href="#">HT1392: “You need to restart your computer” (kernel panic) message appears (Mac OS X v10.5, 10.6)</a></li> <li>Computer freezes during use</li> <li>Computer freezes upon wake from sleep</li> <li>Computer freezes when AirPort is enabled or activated</li> </ul>	<ol style="list-style-type: none"> <li>Collect details from user regarding the kernel panic or crash: when does it happen; what peripherals are in use; what applications are in use; what actions are taking place at the time; and try to establish a set of circumstances so you can recreate the issue effectively.</li> <li>Check for and apply the latest software and firmware updates.</li> <li>Remove suspected external devices.</li> <li>Verify memory configuration matches actual amount of installed physical memory.</li> <li>Hold Shift key during startup to start computer in Safe Mode. See Apple Support article <a href="#">HT1564: Mac OS X: What is Safe Boot, Safe Mode?</a></li> <li>Start up from known-good bootable device with an up-to-date Mac OS X version and proper build. See Apple Support article <a href="#">HT1159: Mac OS X versions (builds) included with Intel-based Macs.</a></li> <li>Check kernel panic log file to look for crash cause. See Apple Support articles <a href="#">HT2546: Mac OS X: How to log a kernel panic</a>, and <a href="#">HT1392: “You need to restart your computer” (kernel panic) message appears (Mac OS X v10.5, 10.6)</a>.</li> <li>If issue cannot be easily reproduced, run Apple Service Diagnostic (ASD) for longer, looping or OS tests.</li> </ol>

### Deep Dive

Check	Result	Action	Code
<ol style="list-style-type: none"> <li>Start up computer to Apple Hardware Test (AHT) on internal hard drive or an inserted Install DVD by holding down the D key at startup. Verify whether computer boots up from any of these volumes.</li> </ol>	Yes	Run extended tests and proceed with results. If AHT passes or boots with a kernel panic, go to step 2.	
	No	Go to step 2.	



2. Remove all peripheral devices including keyboard and mouse. Verify whether computer starts without kernel panic.	Yes	Add peripheral devices one at a time until kernel panic repeats. Replace device causing issue.	
	No	Go to step 3.	
3. Use known-good memory in the system. Verify whether computer start without kernel panic now.	Yes	Install user's memory one by one and retest. If kernel panic repeats, replace affected memory. Verify whether correct memory specification is being used.	<b>X01</b>
	No	Go to step 4.	
4. Wait for 20 seconds after shutdown and disconnect AirPort card from logic board. Verify whether computer starts without kernel panic now.	Yes	Go to <a href="#">AirPort Card Kernel Panic</a> .	
	No	Go to step 5.	
5. Disconnect data cable from hard drive and startup to the Install DVD in the optical drive or from an external volume. Verify whether computer starts without kernel panic now.	Yes	Go to <a href="#">Hard Drive or SSD Not Recognized</a> .	
	No	Go to step 6.	
6. Disconnect Bluetooth/camera/sensor cable and microphone cable from logic board. Verify whether computer starts without kernel panic now.	Yes	Go to <a href="#">AirPort Issues</a> , <a href="#">Bluetooth Issues</a> , <a href="#">Camera Issues</a> or <a href="#">Microphone Issues</a> symptom flow as appropriate.	
	No	Go to step 7.	
7. Disconnect SD cable on logic board. Verify whether computer starts without kernel panic now.	Yes	Go to <a href="#">SD Memory Card Not Recognized</a> .	
	No	Go to step 8	
8. Disconnect optical drive and test. Verify whether computer starts without kernel panic now.	Yes	Go to <a href="#">Optical Drive Not Recognized</a> .	
	No	Replace logic board.	<b>M06</b>



## No Video

Unlikely cause: hard drive, optical drive, speakers, camera

### Quick Check

Symptoms	Quick Check
<p><b>No Video</b></p> <ul style="list-style-type: none"> <li>• Power but no video visible on display</li> <li>• Fan, hard drive spin or optical drive reset sounds audible</li> <li>• Caps Lock key on wired keyboard illuminates when pressed</li> </ul>	<ol style="list-style-type: none"> <li>1. Press F2 key on wired keyboard to increase screen brightness.</li> <li>2. For no-video issues, connect a compatible external display to verify if iMac video circuitry is functioning. If image appears on external display go to <a href="#">Backlight Issue/No Backlight</a>.</li> <li>3. Reset SMC: shut down computer, unplug power cord, press and hold power button for 5 seconds, release power button, and reconnect power cord.</li> <li>4. Reset PRAM by holding down Command-Option-P-R keys while rebooting, until you hear the startup sound for the second time.</li> </ol>

### Deep Dive

Check	Result	Action	Code
1. Verify startup sound present and fans running when computer powered ON. (Reset SMC and PRAM, reseal battery on logic board if necessary and retest for proper start up.)	Yes	Power ON self test OK. Boot sequence started. Go to step 2.	
	No	Go to <a href="#">No Startup</a> .	
2. Verify whether image is visible on built-in LCD panel.	Yes	Video present. Verify computer functionality and return to user or jump to appropriate troubleshooting flow.	
	No	Go to step 3.	
3. Connect supported external display. Verify whether image appears on external display when computer is started up.	Yes	External display detected by system. Video circuitry on logic board functional.  Inspect DisplayPort cable connection to back of LCD panel. Reseat and test again. If you continue to have problems go to <a href="#">Backlight Issue/No Backlight</a> .	
	No	Go to step 4.	



4. Disconnect AC, remove glass and LCD panel to access <a href="#">diagnostic LEDs</a> on center of logic board. Reconnect AC and verify if LED #3 turns on shortly after computer powers on.	Yes	Logic board communicating with video card. Go to step 5.	
	No	If LED #3 does not turn ON reseal video card and retest, then replace video card and repeat step 4. If issue persists, replace logic board.	<b>M03</b> <b>M03</b>
5. Locate <a href="#">diagnostic LEDs</a> on logic board and verify if LED #4 turns on shortly after computer powers on.	Yes	Logic board communicating with LCD panel. Go to <a href="#">Backlight Issue/No Backlight</a> .	
	No	Replace DisplayPort cable. Go to step 6.	<b>X03</b>
6. Locate <a href="#">diagnostic LEDs</a> on the logic board and verify if LED #4 turns on shortly after computer powers on.	Yes	Video controller functional and communicating with LCD panel. Go to <a href="#">Backlight Issue/No Backlight</a> .	
	No	Video controller unable to communicate with LCD panel. Reseat cables first. If issue persists, replace LCD panel. Retest.	<b>L03</b>



## Corrupted Video

Unlikely cause: power supply, hard drive, optical drive, fans, speakers, camera

### Quick Check

Symptoms	Quick Check
<p><b>Corrupted Video</b></p> <ul style="list-style-type: none"> <li>Text and graphics appear fuzzy</li> <li>Image corrupted</li> </ul>	<ol style="list-style-type: none"> <li>Check Apple Support article <a href="#">HT1159: Mac OS X versions (builds) included with Intel-based Macs</a> to make sure system build is correct for this computer model.</li> <li>Set System Preferences &gt; Displays to native resolution of LCD. Non-native resolutions are unable to produce optimal clarity.</li> <li>In System Preferences &gt; Appearance, turn off text smoothing for smaller fonts. Smaller fonts can appear fuzzy or harder to read when smoothing (or “antialiasing”) is on. Ask user if this resolves their issue.</li> <li>Clean outside surface of glass panel.</li> <li>Check for and apply the latest software and firmware updates.</li> <li>Start up from known-good original system media or an up-to-date, bootable Mac OS X volume to determine whether a potential software/driver issue exists.</li> <li>When issue occurs, take a screenshot (Command-Shift-3). View screenshot file on a known-good computer. If image corruption can be seen in the screenshot then issue is with the video drivers, software, or video/logic board. If issue cannot be seen in the screenshot then LCD panel and DisplayPort cable should be tested further.</li> </ol>

### Deep Dive

Check	Result	Action	Code
1. Start up from known-good original system media or an up-to-date, bootable Mac OS X volume and verify whether issue is still visible.	Yes	Go to step 2.	
	No	Issue likely caused by software or driver issue. Troubleshoot for software issues.	



2. Verify whether issue is visible on an external display.	Yes	Issue is NOT caused by internal LCD display. Go to step 3.	
	No	Go to step 6.	
3. Remove video card, inspect connector for damage or corrosion. Reinstall video card and retest. Verify whether issue still occurs.	Yes	Replace video card. Go to step 4.	<b>M04</b>
	No	Issue resolved by reseating video card.	
4. Verify whether video corruption issue is still present.	Yes	Replace logic board. If a video card was replaced, reinstall user's video card. Go to step 5.	<b>M04</b>
	No	Issue resolved with replacement video card.	
5. Verify whether video corruption issue is still present with replacement logic board installed.	Yes	Return to step 1 and retest.	
	No	Issue resolved with replacement logic board.	
6. Inspect glass panel. Verify whether issue is caused by condensation or contaminants on inside/outside surface of glass panel, or on surface of LCD panel.	Yes	Clean glass and/or LCD using procedures in Glass Panel take-apart chapter.  Identify possible sources of contamination (nearby cigarette/cooking smoke, heavy airborne dust, etc.) to prevent recurrence. Condensation should dissipate after computer has been running a few hours.	
	No	Go to step 7.	
7. Disconnect DisplayPort cable between LCD panel and logic board, and verify if there is damage to cable or connectors. Repeat with v-sync cable connected between LCD panel and LED backlight board.	Yes	Replace DisplayPort cable or any other damaged part/module.	<b>X03</b>
	No	Reinstall DisplayPort cable and v-sync cable. Go to step 8.	



<b>8.</b> Verify whether issue is still visible after reinstalling/ replacing DisplayPort cable and v-sync cable.	Yes	If video corruption symptom appears to be like a rolling image (bad location of the top of image), replace v-sync cable and go to step 9.  Else replace DisplayPort cable and go to step 9.	<b>X03</b> <b>X03</b>
	No	Issue resolved with reseating/ replacing damaged cable(s).	
<b>9.</b> Verify whether issue is still visible after replacing DisplayPort cable or/and v-sync cable.	Yes	Replace LCD panel.	<b>L04</b>
	No	Issue resolved with replacing the cable(s).	
<b>10.</b> Verify whether issue is still present with replacement LCD panel installed.	Yes	Contact Apple Technical Support.	
	No	Issue resolved with replacement of LCD panel. Run Apple Service Toolkit Test Patterns Tool test to verify display.	<b>L04</b>



## Burnt Smell/Odor

Unlikely cause: speakers, rear housing

### Quick Check

Symptoms	Quick Check
<b>Burnt Smell/Odor</b> <ul style="list-style-type: none"> <li>Burning smell</li> <li>Unusual odor</li> </ul>	<ol style="list-style-type: none"> <li>Verify that computer is the source of the odor.</li> <li>If computer is new, see Apple Support article <a href="#">TA22044: New Equipment: Odors May Be Present Short-Term</a>.</li> <li>Disconnect all third-party devices and check to see if any external device is the source of odor.</li> <li>Determine if this is a safety issue. Refer to Apple Support article <a href="#">CP1124: SERVICE: Handling Potential Product Safety Issues</a>.</li> <li>Do a quick inspection of enclosure and components for obvious signs of burning or smoky residue. Check rear vents, keyboard, slots, and ports, as well as power cord.</li> <li>Clean enclosure to eliminate any causes from external contamination. Refer to Apple Support article <a href="#">HT3226: How to clean Apple products</a>. Explain the cause to user.</li> <li>Inspect air intake and air outlets for obstructions. To prevent overheating make sure there is sufficient clearance to allow air to flow unobstructed into and out of the computer.</li> <li>Verify if computer is functional.</li> </ol>

### Deep Dive

Check	Result	Action	Code
1. Verify whether source of the odor can be identified by visually inspecting each module and its associated cables for signs of burned or damaged components, smoke residue, burned traces, or melted or damaged wiring,	Yes	Replace affected module(s). Go to step 2	<b>P08</b>
	No	Unable to locate source of odor. Go to step 3.	



2. Disconnect all third-party devices and cables. Power on computer and verify if smoke or strong odor returns.	Yes	Power down computer immediately. Go to step 3.	
	No	Computer functions correctly. Verify third-party devices and cables. Consult third-party companies as needed for issues with those products.	
3. Verify whether source of odor can be located using your nose.	Yes	Check all AC and DC power cables for pinch or damage. Replace affected module(s) and retest.	<b>P08</b>
	No	Contact Apple for assistance if you feel that there is a possible safety issue with computer.	

## Uncategorized Symptoms

### Quick Check

Symptoms	Quick Check
<b>Uncategorized Symptoms</b> <ul style="list-style-type: none"> <li>Unable to locate appropriate symptom code.</li> </ul>	<ol style="list-style-type: none"> <li>Make sure computer is plugged into a known-good outlet.</li> <li>Listen for startup sound, fan, optical drive, or hard drive noise which indicates computer is powering up. If noise is heard, go to <a href="#">No Startup</a>. If no noise is heard go to <a href="#">No Power</a>.</li> <li>Attempt to start up from known-good original system media or an up-to-date, bootable Mac OS X volume to isolate possible software issues.</li> </ol>

### Deep Dive

Check	Result	Action	Code
1. Verify whether existing symptom code applies to issue reported by user.	Yes	Jump to appropriate symptom code flow.	
	No	Document reported failure and send feedback to <a href="mailto:smfeedback6@apple.com">smfeedback6@apple.com</a> stating that a suitable symptom code wasn't found. Provide as much detail as possible.	<b>N99</b>



# Display

## Backlight Issue/No Backlight

Unlikely cause: hard drive, optical drive, speakers, camera

### Quick Check

Symptoms	Quick Check
<b>Backlight Issue/No Backlight</b> <ul style="list-style-type: none"> <li>• Display not illuminated</li> <li>• Flickering, unstable or non-uniform background lighting</li> <li>• Poor backlight at some or all settings</li> <li>• Computer exhibits power, POST chime and fan movement</li> </ul>	<ol style="list-style-type: none"> <li>1. Cover ambient light sensor to mimic a dark room, and adjust brightness to maximum setting using F2 key on wired keyboard.</li> <li>2. Reset PRAM by holding down Command-Option-P-R keys while restarting, until you hear the startup sound for the second time.</li> <li>3. Reset SMC: shut down computer, unplug power cord, press and hold power button for 5 seconds, release power button, and reconnect power cord.</li> <li>4. If no image on built-in display, connect supported external display to verify if iMac video circuitry is functioning. If no image visible on external display, go to <a href="#">No Video</a> symptom flow under Startup and Power.</li> </ol>

### Deep Dive

Check	Result	Action	Code
1. Verify boot chime present and fans running when computer powered ON. (Reset SMC and PRAM if necessary for proper start up.)	Yes	Power on self test OK. Go to step 2.	
	No	Go to <a href="#">No Startup</a> symptom flow.	
2. Verify if image is visible on built-in LCD panel, with adjustable backlight level.	Yes	Video present. Verify computer functionality and return to user or go to appropriate troubleshooting flow.	
	No	Go to step 3.	



3. Connect supported external display. Verify if any image appears on external display after system has started up.	Yes	External display detected by system. Video circuitry on logic board functional. Go to step 4.	
	No	Go to <a href="#">No Video</a> symptom flow.	
4. In System Preferences > Display, set brightness to maximum. Verify if LCD backlight is ON by looking for faint glow from display when viewed in darkened room.	Yes	Able to adjust brightness in System Preferences and faint glow seen. Go to step 7.	
	No	Unable to adjust brightness in System Preferences, or no faint glow. Go to step 5.	
5. Shine bright (low heat) flashlight onto front of LCD. With computer powered ON verify if a faint image is visible.	Yes	LCD panel functional but backlight is missing or dim. Remove LCD panel and inspect and reseal the following cable connections:  -Output cable between lower end of LED backlight board and lower end of LCD panel.  -Vertical sync cable between upper end of LED backlight board and LCD panel.  -DC power cable between upper right of LED backlight board and power supply.  Replace any damaged cable. Reinstall LCD panel and go to step 6.	<b>X03</b>
	No	No image or backlight. Go to step 7.	
6. Power on computer. Verify if image is now visible on LCD panel with correct backlight level.	Yes	Issue resolved.	
	No	Replace LED backlight board. Retest. If issue persists, go to step 7.	<b>M04</b>
7. Inspect and reseal DisplayPort cable between LCD panel and logic board. Power on computer. Verify if image is visible on built-in LCD display.	Yes	Issue resolved.	
	No	Replace DisplayPort cable.  If issue persists, replace LCD panel. Retest.	<b>X03</b>  <b>L03</b>



## Noise / Unstable Flickering

### Quick Check

Symptoms	Quick Check
<p><b>Noise / Unstable Flickering</b></p> <ul style="list-style-type: none"> <li>Flickering image</li> <li>Horizontal bands of static intermittently appear</li> <li>Dock and/or menu bar shift positions</li> <li>Display intermittently flashes on/off</li> <li>Unstable image</li> <li>Humming noise from display</li> <li>High frequency noise from display</li> </ul>	<ol style="list-style-type: none"> <li>If display flicker only occurs when the brightness level is set below maximum, then go to Deep Dive step 6 to verify that the v-sync cable is properly connected.</li> <li>Check for and apply the latest software and firmware updates.</li> <li>Check Apple Support article <a href="#">HT1159: Mac OS X versions (builds) included with Intel-based Macs</a> to make sure system build is correct for this computer model.</li> <li>Verify that intake vents on bottom of computer are not obstructed.</li> <li>Inspect system for third-party software that is being used to set fan speeds to a higher than normal RPM. Some users may install this software to monitor and control internal temperatures, potentially causing higher fan speeds to generate higher than expected noise levels.</li> </ol>

### Deep Dive

Check	Result	Action	Code
1. Verify if user issue is due to flickering, or to an unstable video image on the LCD.	Yes	Suspected flickering issue. Go to step 2.	
	No	For audible noise issues go to step 8. For all other issues go to appropriate symptom flow.	
2. Connect a known-good supported external display. Verify if issue occurs on both the internal and the external display.	Yes	Suspect issue with video circuitry. Go to <a href="#">Corrupted Video</a> symptom flow.	
	No	Video circuitry appears OK. Go to step 3.	
3. When display flickers, verify whether one of the following symptoms occurred: - Flickering image - Horizontal bands of static - Dock and/or menu bar shift positions - Display flashes on/off	Yes	Remove glass and LCD panel. Check, reseal, and secure the DisplayPort cable to both ends. Check and reseal the v-sync cable to both ends. Go to step 4.	
	No	LCD panel OK. Go to step 4.	



4. Power ON computer and verify if issue still occurs.	Yes	If connections are secure and display is still flickering, go to step 5.	
	No	Issue resolved.	
5. Carefully disconnect and verify if any of the four cables on back of LCD panel show signs of damage, corrosion, or pinched wires.	Yes	Replace and damaged cable(s) and retest.	<b>X03</b>
	No	Go to step 6.	
6. Verify whether flickering occurs when brightness level is set below max.	Yes	Image present but backlight is flickering. Replace v-sync cable and retest. If issue persists, replace LED backlight board.	<b>X03</b> <b>M04</b>
	No	Replace DisplayPort cable, retest and go to step 7.	<b>X03</b>
7. Verify if flickering issue is still present.	Yes	Replace LCD panel.	<b>L06</b>
	No	Issue resolved.	
8. Verify if high pitch noise varies when adjusting brightness level up and down.	Yes	Inspect and replace the v-sync cable if it is damaged, otherwise replace LED backlight board. If issue persists, replace power supply.	<b>X03</b> <b>M04</b> <b>P01</b>
	No	Noise is from another source. Go to step 9.	
9. Verify if noise can be heard when computer is set up with user seated in normal user position. Adjusting brightness level up and down may be necessary to recreate issue.	Yes	Replace LED backlight board. Go to step 10.	<b>M04</b>
	No	Noises that are not audible from the normal user position are considered acceptable.	
10. Verify if noise is still present.	Yes	If noise still present, go to <a href="#">Noise/Hum/Vibration</a> symptom flow.	
	No	Issue resolved.	



## LCD Image Issues

Unlikely cause: power supply, hard drive, optical drive, fans, speakers, camera

### Quick Check

Symptom	Quick Check
<b>LCD Issues</b> <ul style="list-style-type: none"><li>• Incorrect/missing colors</li><li>• Distorted/blurred image</li><li>• Pixel anomalies</li><li>• Vertical/horizontal lines</li><li>• Non-uniform brightness</li><li>• Flickering</li></ul>	<ol style="list-style-type: none"><li>1. If display flicker only occurs when the brightness level is set below maximum, then go to <a href="#">Backlight Issue/No Backlight</a> symptom flow.</li><li>2. Check for and apply the latest software and firmware updates.</li><li>3. Check Apple Support article <a href="#">HT1159: Mac OS X versions (builds) included with Intel-based Macs</a> to make sure system build is correct for this computer model.</li><li>4. Isolate software by starting up from known-good original system media or an up-to-date, bootable Mac OS X volume.</li><li>5. Allow display to warm up for 5 minutes before evaluating front-of-screen performance.</li><li>6. Check System Preferences &gt; Displays &gt; Color for use of a custom display profile. If so, select “Color LCD” to revert to default settings.</li><li>7. Check brightness setting.</li><li>8. Clean glass panel and check for dust or debris.</li><li>9. Reset SMC: shut down computer, unplug power cord, press and hold power button for 5 seconds, release power button, and reconnect power cord.</li></ol>



## Deep Dive: General

Check	Result	Action	Code
1. Verify if user issue is due to flickering, or to an unstable video image on the LCD.	Yes	Go to <a href="#">noise / unstable flickering.</a>	
	No	Go to step 2.	
2. Verify if issue is incorrect/missing colors.	Yes	Go to <a href="#">incorrect/missing colors.</a>	
	No	Go to step 3.	
3. Verify if issue is distorted/blurred image.	Yes	Go to <a href="#">distorted/blurred image.</a>	
	No	Go to step 4.	
4. Verify if issue is bright or dark pixel anomalies.	Yes	Go to <a href="#">pixel anomalies.</a>	
	No	Go to step 5.	
5. Verify if issue is vertical or horizontal lines.	Yes	Go to <a href="#">vertical/horizontal lines.</a>	
	No	Go to step 6.	
6. Verify if issue is non-uniform brightness.	Yes	Go to <a href="#">non-uniform brightness/color.</a>	
	No	LCD functioning OK. Return to appropriate symptom flow if user issue is still present.	



## Incorrect/Missing Colors

Unlikely cause: power supply, hard drive, optical drive, fans, speakers, camera

### Quick Check

Symptoms	Quick Check
<b>Incorrect/Missing Colors</b> <ul style="list-style-type: none"> <li>Wrong color display</li> <li>Color/contrast issues</li> </ul>	<ol style="list-style-type: none"> <li>Allow display to warm up for 5 minutes before evaluating front-of-screen performance.</li> <li>Check System Preferences &gt; Displays &gt; Color for use of a custom display profile. If so, select "Color LCD" to revert to default settings.</li> <li>Verify System Preferences &gt; Universal Access &gt; Display "Enhance contrast," "Use grayscale," and "Black on White/White on Black" settings are set to defaults.</li> </ol>

### Deep Dive

Check	Result	Action	Code
1. Verify computer has been warmed up for 5 minutes.	Yes	Go to step 2.	
	No	Warm up computer for 5 minutes. Go to step 2.	
2. Verify if all four cables on back of LCD panel are secure at both ends.	Yes	Go to step 3.	
	No	Reseat connections, replace damaged cable(s) if needed. Retest.	<b>L14</b>
3. Go to System Preferences > Desktop & Screen Saver > Desktop and set color to Solid Gray Light. Verify if incorrect/missing color issue affects entire display.	Yes	Suspect poor video connection. Replace DisplayPort cable between LCD panel and logic board.	<b>L14</b>
	No	Go to step 4.	
4. Set up computer side-by-side with a known-good, same-model computer showing same image. Verify if issue is noticeably worse on display being tested.	Yes	Replace LCD panel.	<b>L02</b>
	No	Small variations in color uniformity across display are normal and do not warrant replacement of LCD.	



## Distorted/Blurred Image

Unlikely cause: power supply, hard drive, optical drive, fans, speakers, camera

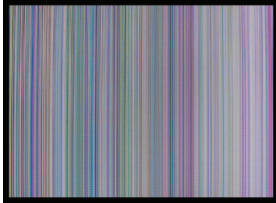

### Quick Check

Symptoms	Quick Check
<b>Distorted/Blurred Image</b> <ul style="list-style-type: none"> <li>Text and graphics appear fuzzy</li> <li>Image corrupted</li> </ul>	<ol style="list-style-type: none"> <li>If display flicker only occurs when the brightness level is set below maximum, then go to <a href="#">Backlight Issue/No Backlight</a> symptom flow.</li> <li>Check for and apply the latest software and firmware updates.</li> <li>Check Apple Support article <a href="#">HT1159: Mac OS X versions (builds) included with Intel-based Macs</a> to make sure system build is correct for this computer model.</li> <li>Set System Preferences &gt; Displays to native resolution of LCD. Non-native resolutions are unable to produce optimal clarity.</li> <li>Clean outside of glass panel.</li> <li>Start up from known-good original system media or an up-to-date, bootable Mac OS X volume to determine if a potential software issue exists.</li> </ol>

### Deep Dive

Check	Result	Action	Code
1. Verify if user issue is due to flickering, or to an unstable video image on the LCD.	Yes	Flickering issue, go to <a href="#">Noise / Unstable Flickering</a> .	
	No	Go to step 2. All other issues go to appropriate symptom flow.	
2. Start up from Install DVD and verify if issue is still visible.	Yes	Go to step 3.	
	No	Check for and apply the latest software and firmware updates.  Check Apple Support article <a href="#">HT1159: Mac OS X versions (builds) included with Intel-based Macs</a> to make sure system build is correct for this computer model.	



3. Verify if issue is visible on an external display attached to Thunderbolt port.	Yes	Issue NOT caused by internal LCD panel. Go to step 7.	
	No	Go to step 4.	
4. Inspect glass panel. Verify if issue is caused by condensation or contaminants on inside surface of glass panel.	Yes	Clean glass and/or LCD using procedures in Glass Panel take-apart chapter.  Identify possible sources of contamination (nearby cigarette/cooking smoke, heavy airborne dust, etc.) to prevent recurrence. Condensation should dissipate after computer has been running a few hours.	
	No	Go to step 5.	
5. Remove glass and LCD panel. Disconnect DisplayPort cable between LCD panel and logic board, and verify if there is damage to cable or connectors.  Repeat with v-sync cable connected between LCD panel and LED backlight board.	Yes	Replace DisplayPort cable, v-sync cable or any other damaged part/module.	<b>X03</b>
	No	Reinstall DisplayPort cable and v-sync cable. Go to step 6.	
6. Verify if issue is still visible after reinstalling internal DisplayPort cable and v-sync cable.	Yes	Replace LCD panel.	<b>L04</b>
	No	Issue resolved.	
7. Remove video card, inspect connector for damage or corrosion then reinstall. Verify if issue still occurs.	Yes	Replace video card. Go to step 8.	
	No	Issue likely caused by poor video card connection.	
8. Verify if distorted/blurred image issue is still present.	Yes	Replace logic board. Go to step 9	<b>M04</b>
	No	Issue resolved.	
9. Verify if issue is still present with replacement logic board installed.	Yes	Return to step 1 and retest.	
	No	Issue resolved.	



## Pixel Anomalies

Unlikely cause: logic board, power supply, hard drive, optical drive, fans, speakers, camera

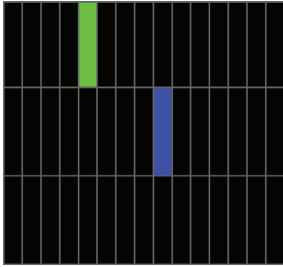

### Quick Check

Symptoms	Quick Check
<b>Pixel Anomalies</b> <ul style="list-style-type: none"> <li>Dark dot anomalies</li> <li>Bright dot anomalies</li> <li>Debris on inside surface of glass panel</li> <li>Debris on surface of LCD panel</li> </ul>	<ol style="list-style-type: none"> <li>Clean outside surface of glass panel.</li> <li>See Apple Support article <a href="#">HT4044: About LCD display pixel anomalies for Apple products released in 2010 and later</a>.</li> </ol>

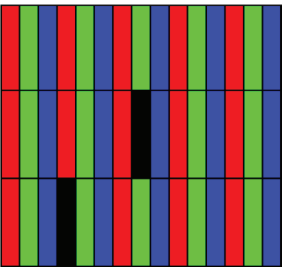

### Deep Dive

Check	Result	Action	Code
1. Determine if anomalies are dust/debris on surface of glass panel or LCD.	Yes	Clean glass and/or LCD using procedures in Glass Panel take-apart chapter.	
	No	Go to step 2.	
2. Determine if bright pixel anomalies exceed acceptable number. See Apple Support article <a href="#">HT4044: About LCD display pixel anomalies for Apple products released in 2010 and later</a> .	Yes	Replace LCD panel.	<b>L08</b>
	No	LCD panel meets bright pixel specifications. Go to step 3.	
3. Determine if dark pixel anomalies exceed acceptable number. See Apple Support article <a href="#">HT4044: About LCD display pixel anomalies for Apple products released in 2010 and later</a> .	Yes	Replace LCD panel.	<b>L08</b>
	No	LCD panel meets dark pixel specifications. Go to step 4.	
4. Determine if combination of bright/dark pixel anomalies exceed acceptable number. See Apple Support article <a href="#">HT4044: About LCD display pixel anomalies for Apple products released in 2010 and later</a> .	Yes	Replace LCD panel.	<b>L08</b>
	No	Explain to user that LCD panel is operating within specifications for pixel anomalies. Do NOT replace LCD panel.	



## Vertical/Horizontal Lines

Unlikely cause: power supply, hard drive, optical drive, fans, speakers, camera



### Quick Check

Symptoms	Quick Check
<b>Vertical/Horizontal Lines</b> <ul style="list-style-type: none"> <li>Vertical lines</li> <li>Horizontal lines</li> </ul>	<ol style="list-style-type: none"> <li>Start up from known-good original system media or an up-to-date, bootable Mac OS X volume to determine if potential software issue exists.</li> <li>Check for and apply the latest software and firmware updates.</li> <li>Verify if issue is visible on an external display.</li> </ol>

### Deep Dive

Check	Result	Action	Code
1. Start up from known-good original system media or an up-to-date, bootable Mac OS X volume and verify if issue is still visible.	Yes	Go to step 2.	
	No	Issue likely caused by software or driver issue. Troubleshoot for software issues.	
2. Verify if issue is visible on an external compatible display.	Yes	Issue NOT caused by internal LCD. Go to step 3.	
	No	Go to step 4.	
3. Remove video card and inspect connector for damage or corrosion then reinstall. Verify if issue still occurs.	Yes	Replace video card. Go to step 8.	<b>M24</b>
	No	Issue likely caused by poor video card connection.	
4. Disconnect DisplayPort cable between LCD display and logic board, and verify if there is damage to cable or connectors.  Repeat with vertical sync cable connected between LCD panel and LED backlight board.	Yes	Replace DisplayPort cable and vertical sync cable or any other damaged part/module. Go to step 5.	<b>X04</b>
	No	Reinstall DisplayPort cable and vertical sync cable. Go to step 5.	
5. Verify if issue is still present after reinstalling DisplayPort cable.	Yes	Replace logic board. If video card was present, reinstall original video card. Go to step 6.	<b>M04</b>
	No	Issue resolved.	



6. Verify if issue is still present with replacement logic board installed.	Yes	Go to step 7.	
	No	Issue resolved.	
7. Reinstall original logic board and verify if issue is still present with original logic board.	Yes	Replace LCD panel.	<b>L04</b>
	No	Issue resolved. If video card was replaced, reinstall original video card.	



## Non-Uniform Brightness / Color

Unlikely cause: power supply, hard drive, optical drive, fans, speakers, camera



### Quick Check

Symptoms	Quick Check
<b>Non-Uniform Brightness</b> <ul style="list-style-type: none"> <li>Brightness not uniform</li> <li>Color not-uniform</li> </ul>	<ol style="list-style-type: none"> <li>Verify System Preferences &gt; Displays &gt; Brightness slider is set above minimum.</li> <li>Allow display to warm up for 5 minutes before evaluating front-of-screen performance.</li> <li>Visually inspect glass panel for presence of dust, cigarette smoke, or other contaminants. Clean glass panel if needed.</li> <li>Run latest available service utilities to check for correct LCD panel temperature.</li> </ol>

### Deep Dive

Check	Result	Action	Code
1. Determine if brightness uniformity issue is visible after display has warmed up for 5 minutes.	Yes	Go to step 2.	
	No	Display backlight can take a minute to stabilize. Retest. If issue still not visible return computer to user.	
2. Look at user-provided examples showing brightness uniformity issue. Determine if variation in uniformity appears excessive when compared to another same-model computer.	Yes	Go to step 3.	
	No	Demonstrate to user that LCD performs similarly to another computer of the same model.	
3. Remove glass panel and loosen screws securing LCD panel. Determine if brightness uniformity improves.	Yes	Inspect for mechanical interference with screws or cables making contact with back of LCD. Reseat components & cables, retest.	
	No	Go to step 4.	
4. Remove LCD panel, then inspect and reseat backlight cables. Determine if brightness uniformity improves.	Yes	One or more backlight cables were loose.	
	No	Replace LCD panel.	<b>L07</b>



## Cosmetic Issues

Symptoms	Quick Check
<b>Cosmetic Issues</b> <ul style="list-style-type: none"> <li>Cracked glass panel</li> <li>Cracked LCD</li> <li>Scratched LCD polarizer</li> <li>Scorched or melted LCD</li> <li>LCD impact damage</li> <li>Foreign material on LCD or back side of glass panel.</li> </ul>	<ol style="list-style-type: none"> <li>Replace glass panel. Refer to Take Apart/ General Information/ How to Remove a Broken Glass Panel.</li> <li>Determine if damage was caused by user environment, accidental damage, or abuse. If applicable, inform user that Apple does not warrant damage caused by accident, abuse, misuse, flood, fire, earthquake, or other external causes. For more information, refer to: <a href="http://www.apple.com/legal/warranty">http://www.apple.com/legal/warranty</a></li> <li>For dark and bright pixel anomalies see <a href="#">Pixel Anomalies</a>.</li> </ol>

## Uncategorized Symptoms

### Quick Check

Symptoms	Quick Check
<b>Uncategorized Symptoms</b> <ul style="list-style-type: none"> <li>Unable to locate appropriate symptom code.</li> </ul>	<ol style="list-style-type: none"> <li>Make sure brightness level is set above minimum.</li> <li>Clean glass panel to make sure external contaminants are removed prior to evaluating display performance.</li> <li>Allow display to warm up for 5 minutes before evaluating front-of-screen performance.</li> </ol>

### Deep Dive

Check	Result	Action	Code
1. Verify if existing symptom code applies to issue reported by user.	Yes	Jump to appropriate symptom code flow.	
	No	Document reported failure and send feedback to <a href="mailto:smfeedback6@apple.com">smfeedback6@apple.com</a> stating that a suitable symptom code wasn't found. Provide as much detail as possible.	<b>N99</b>



# Mass Storage

## Hard Drive or SSD Not Recognized

Unlikely cause: LCD panel, power supply, optical drive, fans, speakers, camera

### Quick Check

Symptoms	Quick Check
<p><b>Drive Not Recognized</b> <b>Drive No Boot</b></p> <ul style="list-style-type: none"> <li>Boots to gray screen</li> <li>Boots to blue screen</li> <li>Flashing folder with question mark or prohibitory symbol.</li> </ul> <p>(Review Apple Support article <a href="#">HT2674: Intel-based Mac: Startup sequence and error codes, symbols</a>)</p>	<p><b>Important: Always inquire whether the user's data has been backed up prior to repair.</b></p> <ol style="list-style-type: none"> <li>Disconnect all peripherals and attempt to start up computer.</li> <li>Use a known-good mouse. A stuck mouse button will not allow boot.</li> <li>To revert startup drive preferences to their defaults, reset PRAM by holding down Command-Option-P-R keys while restarting, until you hear the startup sound for the second time.</li> <li>Start up from known-good original system media or an up-to-date, bootable Mac OS X volume.</li> <li>Use Mac Resource Inspector (MRI) or Disk Utility to verify S.M.A.R.T. status of internal drive.</li> <li>Use Target Disk Mode to mount internal drive in user's computer on a known-good computer. Use Disk Utility on host computer to verify S.M.A.R.T. status of internal drive in user's computer.</li> </ol>

### Deep Dive

Check	Result	Action	Code
1. Boot from Install DVD and run Disk Utility. Verify if user's drive is available for Disk Utility to repair.	Yes	Go to step 2.	
	No	Go to step 5.	
2. Run Disk Utility's "Repair Disk" function and verify if it completes successfully.	Yes	Go to step 3.	
	No	Go to step 4.	
3. Restart computer. Verify if system starts up successfully and that Disk Utility "Verify" function reports no errors.	Yes	Data error. Issue resolved.	
	No	Go to step 4.	



4. With user's permission, erase internal drive and reinstall Mac OS. Verify if installation process completes.	Yes	Go to step 8.	
	No	Go to step 5.	
5. Check that the power cable is correctly connected to the drive. Inspect drive data and power cable and connectors for bent pins, or other damage to the cable(s).	Yes	Replace any damaged data or power cables. Go to step 8.	<b>X03</b>
	No	Go to step 6.	
6. Reseat drive data cable at logic board and drive ends, and verify if computer starts up successfully.	Yes	Go to step 8.	
	No	Replace drive data cable. Go to step 8.	<b>X03</b>
7. Test with a known-good bootable drive. Verify if system starts up successfully and that Disk Utility "Verify" function reports no errors.	Yes	Reinstall user's drive. Go to step 9.	
	No	Drive data cable was verified or replaced, and known-good drive is installed: -If hard drive does not spin up when system is powered on, replace hard drive power cable. -If hard drive spin up sound can be heard when system is powered on, but computer cannot boot from it, replace logic board.	<b>X03</b>  <b>M19</b>
8. Restart computer. Verify if system starts up successfully and that Disk Utility "Verify" function reports no errors.	Yes	Issue resolved. Return computer to user.	
	No	Go to step 7.	
9. Restart computer. Verify if system starts up successfully and that Disk Utility "Verify" function reports no errors.	Yes	Issue resolved.	
	No	User's drive appears to have an issue. Go to step 10.	
10. Substitute a known-good hard drive. Boot from system-specific Install DVD and reinstall Mac OS X with drive format option. Verify if drive is formatted correctly (GUID partition table) and that software restore was successful.	Yes	Replace hard drive or SSD as appropriate.	<b>H01</b>
	No	Drive data cable verified/ replaced and known-good drive installed, Check with known-good restore DVD. If restore failure still happens, go to step 11.	



<b>11.</b> If restore from Install DVD is unsuccessful, startup a known-good Intel Mac system with T key pressed (to enter Target Disk Mode), insert the iMac Install DVD in its optical drive and connect it to the user's system via a FireWire cable. Start up user's computer while holding Option key, then select and boot from the Install Disc DVD and restore system software. Verify if software restore was successful.	Yes	Restore failure seems to be due to user's internal optical drive or media issue. Go to <a href="#">Optical Drive Read/Write Error</a> .	
	No	Restore failure seems to be due to internal SATA bus issue. Replace logic board.	<b>M19</b>

## Hard Drive Read/Write Errors

Unlikely cause: LCD panel, power supply, optical drive, fans, speakers, camera

### Quick Check

Symptoms	Quick Check
<b>Drive Read/Write Error</b> <b>Drive Bad Sector/Defective</b> <b>Drive Formatting Issues</b> <ul style="list-style-type: none"> <li>• Cannot save documents</li> <li>• Read/write error message</li> <li>• Hang when accessing or saving data</li> </ul>	<b>Important: Always inquire whether the user's data has been backed up prior to repair.</b> <ol style="list-style-type: none"> <li>1. Start up from known-good original system media or an up-to-date, bootable Mac OS X volume.</li> <li>2. Use Mac Resource Inspector (MRI) or Disk Utility to verify S.M.A.R.T. status of internal hard drive.</li> <li>3. Use Target Disk Mode to mount internal hard drive in user's computer on a known-good computer. Use Disk Utility on host computer to verify S.M.A.R.T. status of internal hard drive in user's computer.</li> </ol>

### Deep Dive

Check	Result	Action	Code
<b>1.</b> Run Disk Utility 'Repair Disk' function, and verify if it completes successfully.	Yes	Go to step 2.	
	No	Go to step 3.	
<b>2.</b> Restart computer. Verify if system starts up successfully and that Disk Utility "Verify" function reports no errors.	Yes	Data error. Issue resolved.	<b>H07</b>
	No	Go to step 3.	



3. With user's permission, erase internal drive(s) containing Mac OS X, and reinstall it. Verify if installation process completes.	Yes	Go to step 6.	
	No	Go to step 4.	
4. Inspect internal hard drive data and power cables and connectors for bent pins, or other damage to the cable.	Yes	Replace damaged cable. Go to step 6.	<b>H04</b>
	No	Go to step 5.	
5. Reseat hard drive data cable at both hard drive and logic board. Verify if computer starts up.	Yes	Go to step 6.	
	No	Replace hard drive data cable. Go to step 6.	<b>H04</b>
6. Restart computer. Verify if system starts up successfully and Disk Utility "Verify" function reports no errors.	Yes	Issue resolved.	
	No	Go to step 7.	
7. Test with known-good bootable drive. Verify if system starts up successfully and Disk Utility "Verify" function reports no errors.	Yes	Reinstall user's drive, go to step 8.	
	No	Hard drive data cable verified or replaced and known-good drive installed used without success. Replace logic board.	<b>M19</b>
8. Restart computer. Verify if system starts up successfully and that Disk Utility "Verify" function reports no errors.	Yes	Issue resolved.	
	No	User's drive appears to be defective. Go to step 9.	
9. Replace user's drive. Verify if drive formats correctly with a GUID partition map and installs Mac OS without errors.	Yes	Issue resolved by replacing user's drive.	<b>H03</b>
	No	Hard drive data cable verified or replaced and new drive did not resolve issue. Replace logic board.	<b>M19</b>



## Hard Drive Noisy

Unlikely cause: LCD panel, logic board, power supply, speakers, camera

### Quick Check

Symptoms	Quick Check
<p><b>Hard Drive Noisy</b></p> <ul style="list-style-type: none"> <li>Noise during start up</li> <li>Noise during operation</li> <li>Noise when drive is copying or saving data</li> </ul>	<p><b>Note:</b> Be sure you understand what type of hard drive noise you should be concerned about, and what noise you can safely ignore. Not all hard drive noise is bad; some hard drive noise is normal.</p> <p>Noises such as occasional quiet chirping or beeping are typically normal hard drive sounds.</p> <p>Refer to Apple Support article <a href="#">TS3204: iMac: Evaluating normal noises</a>, to determine if noise is within expected range.</p> <p>Abnormal noises such as grinding, or loud, repeated clicking, or scraping sounds may be indications of a more serious issue.</p> <p>Listen closely in a quiet environment for:</p> <ul style="list-style-type: none"> <li>Noise during start up</li> <li>Noise during operation</li> <li>Noise when drive is copying or saving data</li> </ul> <p><b>Important: Always inquire whether the user's data has been backed up prior to repair.</b></p> <ol style="list-style-type: none"> <li>Verify that user's issue involves only abnormal sounds, as defined above.</li> <li>Compare hard drive noise to a known-good equivalent computer.</li> </ol>

### Deep Dive

Check	Result	Action	Code
1. Boot from the Install DVD and run Disk Utility. Verify if user hard drive is available for Disk Utility to repair.	Yes	Go to step 2.	
	No	Go to <a href="#">Hard Drive or SSD Not Recognized</a> .	
2. Run Disk Utility 'Repair Disk' function and verify if it completes successfully.	Yes	Go to step 3.	
	No	Go to step 4.	
3. Restart computer and verify if the noise is still present.	Yes	Go to step 4.	
	No	Issue resolved. Return computer to user.	



4. Disconnect hard drive data cable and retest (with an external display connected). Verify if the noise is still present.	Yes	Noise issue still present, but does not appear to be caused by hard drive. Go to <a href="#">Noise/Hum/Vibration</a> .	
	No	Go to step 5.	
5. Remove hard drive and verify if rubber vibration isolation grommets are properly installed in hard drive bracket (attached to hard drive) and to mechanism in rear housing (where hard drive pins insert).	Yes	Go to step 6.	
	No	If grommets are missing or damaged, replace hard drive bracket or mechanism as appropriate. Go to step 6.	
6. Restart system and verify if the noise is still present.	Yes	Go to step 7.	
	No	Reseating or replacing the drive rubber grommets / bracket solved noise issue.	
7. Reconnect user's drive and, with user's permission, erase hard drive and reinstall Mac OS. Verify if installation process completes.	Yes	Go to step 8.	
	No	Replace hard drive. Go to step 9.	
8. Restart system and verify if the noise is still present.	Yes	Replace hard drive. Go to step 9.	
	No	Software related issue.	
9. With replacement hard drive installed, restart computer. Verify if noise is still present.	Yes	Replacement hard drive did not resolve issue. Go to step 10 to check for other source of noise.	
	No	Issue resolved by replacing hard drive.	<b>H06</b>
10. Disconnect hard drive data and power cables then boot from the Install DVD. Verify if noise is caused by fans.	Yes	Go to <a href="#">Fan Failures/Thermal Issues</a> .	
	No	Go to step 11.	
11. Disconnect hard drive and optical drive then start up from an external volume. Verify if noise disappears when optical drive has been disconnected.	Yes	Possible optical drive or media issue. Go to <a href="#">Optical Drive Noisy</a> .	
	No	Noise issue still present, but does not appear to be caused by hard drive. Go to <a href="#">Noise/Hum/Vibration</a> .	



## Optical Drive Not Recognized

Unlikely cause: LCD panel, power supply, fans, speakers, camera

### Quick Check

Symptoms	Quick Check
<b>Drive Not Recognized/Mount</b> <ul style="list-style-type: none"><li>Discs inject and eject, but do not appear in Finder</li></ul>	<ol style="list-style-type: none"><li>1. Check Finder Preferences &gt; General and make sure "CDs, DVDs and iPods" is checked under "Show these items on the Desktop."</li><li>2. Check affected optical media for presence of physical damage(s) on its surface.</li><li>3. Test with known-good optical media.</li><li>4. Use Mac Resource Inspector (MRI), Disk Utility, or System Profiler Serial-ATA section to verify if optical drive is recognized by computer.</li><li>5. Check Disk Utility or System Profiler Serial-ATA section for presence of an inserted optical media.</li><li>6. Check for and apply the latest software and firmware updates.</li><li>7. Refer to Apple Support article <a href="#">HT1159: Mac OS X versions (builds) included with Intel-based Macs</a>, and verify that the correct version of OS X is installed.</li><li>8. Reset PRAM by holding down Command-Option-P-R keys while rebooting, until you hear the startup sound for the second time.</li><li>9. Reset SMC: shut down computer, unplug power cord, press and hold power button for 5 seconds, release power button, and reconnect power cord.</li></ol>



## Deep Dive

Check	Result	Action	Code
1. Verify if optical drive is listed in Serial-ATA section of System Profiler.	Yes	Go to step 2.	
	No	Go to step 3.	
2. Test both CD and DVD media. Verify if optical drive can read both CD and DVD media.	Yes	No issue, or possible intermittent issue. Gather more information from user.	
	No	If both types of media fail, check that Finder Preferences are set to “show CD’s and DVD’s;” then go to step 3.  If only one type of media fails, drive has a laser pickup issue. Replace optical drive.	<b>J03</b>
3. Connect known-good optical drive to SATA cable. Verify if both CD and DVD media are read reliably.	Yes	SATA cable and port on logic board appear good. Go to step 5.	
	No	Go to step 4.	
4. Reseat SATA cable connections at optical drive and logic board (cable connects to back of logic board). Verify if both CD and DVD media are read reliably.	Yes	Go to step 6.	
	No	Replace optical drive SATA cable and test.  If issue persists, replace logic board.  Go to step 6.	<b>X03</b>  <b>M19</b>
5. Connect original optical drive to known-good SATA cable. Verify if both CD and DVD media are read reliably.	Yes	SATA cable issue. Replace SATA cable. Go to step 6.	<b>X03</b>
	No	Replace optical drive.	<b>J03</b>
6. Test read compatible known-good CD and DVD media (Install DVD). Verify if media is recognized and reads reliably.	Yes	Issue resolved.	
	No	Replace optical drive.	<b>J03</b>



## Optical Drive Rejects or Does Not Accept Media

Unlikely cause: LCD panel, power supply, fans, speakers, camera

### Quick Check

Symptoms	Quick Check
<p><b>Optical Drive Rejects or Does Not Accept Media</b></p> <ul style="list-style-type: none"> <li>• Cannot insert a disc into drive</li> <li>• Drive ejects discs immediately after insertion</li> <li>• Cannot eject a disc placed into drive</li> </ul>	<ol style="list-style-type: none"> <li>1. Check affected optical media for presence of physical damage(s) on its surface.</li> <li>2. Use Mac Resource Inspector (MRI), Disk Utility, or System Profiler Serial-ATA section to verify if optical drive is recognized by computer. If drive is not recognized, go to <a href="#">Optical Drive Not Recognized</a>.</li> <li>3. Restart computer and hold down mouse button or keyboard eject key to cycle optical drive.</li> <li>4. Inspect optical drive slot for obstructions.</li> </ol>

### Deep Dive

Check	Result	Action	Code
1. Use Mac Resource Inspector (MRI), Disk Utility, or System Profiler Serial-ATA section to verify if optical drive is recognized by computer.	Yes	Optical drive communicating with logic board. Go to step 5.	
	No	Go to step 2.	
2. Verify SATA cable connections between optical drive and logic board. Visually inspect cables and connectors for any debris, damage or bent pins. Verify if optical drive is listed in System Profiler device tree.	Yes	Optical drive communicating with logic board. Go to step 5.	
	No	Replace damaged cables and retest. If connections are good and no visible cable damage, go to step 3.	<b>X03</b>
3. Connect known-good optical drive to SATA cable. Verify if known-good optical drive is listed in the System Profiler device tree.	Yes	Go to step 4.	
	No	Suspect bad SATA cable. Go to step 7.	
4. With known-good optical drive installed, test for media inject/eject. Verify if drive accepts and ejects known-good media.	Yes	Known-good optical drive resolved inject/eject issue. Replace optical drive.	<b>J03</b>
	No	Go to step 7.	



5. Inspect optical drive slot during disc insert/eject. Verify if discs can be inserted easily and don't get scraped during insertion/ejection.	Yes	Go to step 6.	
	No	Verify correct optical drive bezel alignment with enclosure. Reseat optical drive then retest. If issue persists, replace optical drive.	<b>J03</b>
6. With known-good optical media (Install DVD), test for media inject/eject. Verify if drive accepts and ejects known-good media.	Yes	Media issue. No repair necessary. Suggest user investigate use of different media.	
	No	Go to step 3.	
7. Replace SATA cable then test for media inject/eject. Verify if drive injects and ejects known-good media.	Yes	SATA cable resolved issue. Return computer to user.	<b>X03</b>
	No	SATA cable verified or replaced, and optical drive verified or replaced. Replace logic board and retest.	<b>M19</b>



## Optical Drive Read/Write Error

Unlikely cause: LCD panel, power supply, fans, speakers, camera

### Quick Check

Symptoms	Quick Check
<p><b>Optical Drive Read/Write Error</b></p> <ul style="list-style-type: none"> <li>• Errors when writing optical media.</li> <li>• Errors when reading optical media.</li> <li>• Hang when accessing or preparing to write data.</li> </ul>	<ol style="list-style-type: none"> <li>1. Check affected optical media for presence of physical damage(s) on its surface.</li> <li>2. Test with known-good optical media.</li> <li>3. Run Mac Resource Inspector (MRI) to check for optical drive thermal sensor.</li> <li>4. Test optical media in a known-good optical drive in the same type of computer to rule out media issue.</li> <li>5. Check with known-good discs like the Install DVD that came with the computer.</li> <li>6. For write issues, try lowering the burn speed with user's media. Check with known-good media that performs well in a known-good optical drive of the same type of computer.</li> <li>7. Check Disk Utility or System Profiler Serial-ATA section for presence of an inserted optical media.</li> <li>8. Check for and apply the latest software and firmware updates.</li> <li>9. Refer to Apple Support article <a href="#">HT1159: Mac OS X versions (builds) included with Intel-based Macs</a>, and verify that the correct version of OS X is installed.</li> <li>10. Reset PRAM by holding down Command-Option-P-R keys while rebooting, until you hear the startup sound for the second time.</li> <li>11. Reset SMC: shut down computer, unplug power cord, press and hold power button for 5 seconds, release power button, and reconnect power cord.</li> </ol>

### Deep Dive

Check	Result	Action	Code
1. Verify if media is free to spin without optical drive scraping edge or surface of media.	Yes	Go to step 3.	
	No	Go to step 2.	



2. Reseat optical drive in rear housing and verify that a media can be inserted without being scratched.	Yes	Go to step 3.	
	No	Replace optical drive and retest.	<b>J05</b>
3. Test both CD and DVD media. Verify if drive can read both CD and DVD media.	Yes	Go to step 7.	
	No	If both types of media fail, check that Finder Preferences are set to "show CD's and DVD's"; then go to step 4.  If only one type of media fails, drive has a laser pickup issue. Replace optical drive.	<b>J03</b>
4. Install known-good optical drive and verify if both CD and DVD media are read reliably.	Yes	Both SATA cable and port on logic board appear good. Go to step 6.	
	No	Go to step 5.	
5. Continue to use known-good optical drive. Reseat optical drive cable connection at logic board ends (cable connects to back of logic board). Verify if both CD and DVD media are read reliably.	Yes	Go to step 6.	
	No	Replace SATA cable and retest. If issue persists, replace logic board. Go to step 7.	<b>X03</b> <b>M19</b>
6. Reinstall user's optical drive and verify if both CD and DVD media are read reliably.	Yes	Go to step 7.	
	No	Replace optical drive.	<b>J03</b>
7. Test write data to compatible CD and DVD media. Verify if burned media is recognized and read reliably.	Yes	Issue resolved.	
	No	Run the latest Apple service diagnostic tests for ODD sensor and ODD fan.  If errors found check ODD sensor and ODD fan connections to logic board (read/write errors may be due to drive getting too hot).  If no errors are found, replace optical drive.	<b>J03</b>



## Optical Drive Not Performing to Specifications

Unlikely cause: LCD panel, power supply, fans, speakers, camera

### Quick Check

Symptoms	Quick Check
<b>Optical Drive Not Performing to Specifications</b> <ul style="list-style-type: none"> <li>Read or write speeds slower than expected</li> </ul>	<ol style="list-style-type: none"> <li>Test optical media in another computer of the same type to rule out media issue.</li> <li>For write issues, check with known-good media that performs well in another computer and drive of the same type.</li> <li>Run latest service utilities to check optical drive thermal sensor status.</li> </ol>

### Deep Dive

Check	Result	Action	Code
1. Test both CD and DVD media. Verify if optical drive can read both CD and DVD media.	Yes	Go to step 5.	
	No	If both types of media fail, check that Finder Preferences are set to "show CD's and DVD's", then go to step 2.  If only one type of media fails, drive has a laser pickup issue. Replace optical drive.	<b>J03</b>
2. Connect known-good optical drive to SATA cable. Verify if both CD and DVD media are read reliably.	Yes	SATA cable and port on logic board good. Go to step 4.	
	No	Go to step 3.	
3. Reseat SATA cable connections at optical drive and logic board (cable connects to back of logic board). Verify if both CD and DVD media are read reliably.	Yes	Go to step 5.	
	No	Replace SATA cable and test.  If issue persists, replace logic board.  Go to step 5.	<b>X03</b> <b>M19</b>
4. Connect original optical drive to known-good SATA cable. Verify if both CD and DVD media are read reliably.	Yes	SATA cable issue. Replace SATA cable. Go to step 5.	<b>X03</b>
	No	Replace optical drive.	<b>J03</b>
5. Test write data to compatible CD and DVD media. Verify if burned media is recognized and read reliably.	Yes	Issue resolved.	
	No	Go to step 6.	



<b>6.</b> Media that is out of balance may not perform well at higher speeds even though higher speeds may be supported by the optical drive. Verify if slowing requested burn speed allows discs to be written reliably.	Yes	Media issue. No repair necessary.	
	No	Go to step 7.	
<b>7.</b> Test write data to compatible CD and DVD media. Verify burned media is recognized and reads reliably.	Yes	Issue resolved.	
	No	Check ODD sensor and ODD fan in latest service utilities:  If errors found check ODD sensor and ODD fan connections to logic board (read/write errors may be due to drive being too hot).  If no errors are found while running diagnostics, replace optical drive.	<b>J03</b>



## Optical Drive Noisy

Unlikely cause: LCD panel, power supply, fans, speakers, camera

### Quick Check

Symptoms	Quick Check
<p><b>Optical Drive Noisy (J04)</b></p> <ul style="list-style-type: none"> <li>• Noise during boot</li> <li>• Noise during operation</li> <li>• Noise when drive is copying or writing data</li> </ul>	<p><b>Note:</b> As a technician, it's important to know what optical drive noise you should be concerned about, and what noises you can safely ignore. The following lists help distinguish normal, functional optical drive sounds from noises that may indicate drive malfunction.</p> <p>Typical noises include sounds made during the following activities:</p> <ul style="list-style-type: none"> <li>• Waking the computer from sleep</li> <li>• Burning a CD or DVD</li> <li>• Inserting a disc</li> <li>• Ejecting a disc</li> <li>• Importing ("ripping") an audio CD in iTunes</li> <li>• Playing a DVD</li> <li>• Accessing an idle disc</li> </ul> <p>Abnormal noises include: grinding; loud, repeated clicking; scraping sounds; or constantly seeking or cycling the eject mechanism with no disc inserted.</p> <p>Listen closely in a quiet environment for:</p> <ul style="list-style-type: none"> <li>• Noise during start up</li> <li>• Noise during operation</li> <li>• Noise when drive is copying or saving data</li> </ul> <ol style="list-style-type: none"> <li>1. Test optical media in another computer of the same type to rule out media issue.</li> <li>2. Check with known-good discs like the Install DVD that came with the computer.</li> <li>3. Verify if noise occurs without media in optical drive. If so, verify if noise made by hard drive or fans.</li> <li>4. Refer to Apple Support article <a href="#">TS3204: iMac: Evaluating normal noises</a>.</li> </ol>



## Deep Dive

Check	Result	Action	Code
1. Test optical drive with different source of media. Does the noise issue remain?	Yes	Go to step 2.	
	No	Issue due to unbalanced media. Recommend using different media.	
2. Reseat optical drive. Does noise issue remain?	Yes	Go to step 3.	
	No	Issue resolved by reseating drive.	
3. Substitute known-good optical drive. Does noise issue remain?	Yes	Go to step 4.	
	No	Replace optical drive.	<b>J04</b>
4. Compare system with similar model for optical drive noise in operation and verify that noise level is similar.	Yes	Noise level of optical drive appears to be within specification. Return computer to user.	
	No	Check for other causes of noise in the computer.	



## SD Memory Card Cannot Be Inserted Into Slot

Unlikely cause: LCD panel, logic board, optical drive, hard drive

### Quick Check

Symptom	Quick Check
<b>SD Memory Card Cannot Be Inserted Into Slot</b> <ul style="list-style-type: none"> <li>SD memory card does not fully seat into slot</li> <li>Card slot does not align with enclosure.</li> </ul>	<ol style="list-style-type: none"> <li>Check that user's SD card is not warped or damaged, and its metal contacts are clean, intact and free of contamination.</li> <li>Verify that SD card is the correct size. Card dimensions should be 32mm x 24mm x 2.1mm. Cards thicker than 2.1mm are too thick and may damage the card slot if inserted. Thinner cards such as MultiMediaCards (MMC) are acceptable. Refer to Apple Support article <a href="#">HT3553: About the SD and SDXC card slot</a>.</li> <li>Verify that computer's SD card slot is not obstructed in any way. Use a flashlight to look into the slot to make sure nothing is already inserted. If so, carefully remove obstruction from slot. Try to insert SD card again.</li> </ol>

### Deep Dive

Check	Result	Action	Code
1. Verify if known-good SD card fits in slot.	Yes	Ask user to replace defective or out-of-spec SD card.	
	No	Loosen the SD board screws, then insert known-good SD card again. Go to step 2.	
2. Verify if known-good SD card now fits in slot.	Yes	Tighten SD reader board screws. Go to step 3.	
	No	Replace SD card reader, retest.	<b>X24</b>
3. Verify if SD card now ejects and inserts without issue.	Yes	Issue resolved by SD card reader alignment.	
	No	Replace SD card reader.	<b>X24</b>



## SD Memory Card Not Recognized

Unlikely cause: LCD panel, logic board, optical drive, hard drive

### Quick Check

Symptom	Quick Check
<b>SD Card Not Recognized</b> <ul style="list-style-type: none"><li>• Card does not show up on desktop or in System Profiler</li></ul>	<ol style="list-style-type: none"><li>1. Make sure SD card is unlocked.</li><li>2. Check that user's SD card is not warped or damaged, and its metal contacts are clean, intact and free of contamination.</li><li>3. Verify that SD card slot in computer is not damaged or obstructed in any way. Use a flashlight to look into the slot to make sure nothing is already inserted. If so, carefully remove obstruction from slot. Try to insert SD card again.</li><li>4. Check for compatible SD card type and format:<ul style="list-style-type: none"><li>• Only Standard SD (Secure Digital), SDHC (Secure Digital High Capacity) and MultiMediaCards (MMC) are supported. See Apple Support article <a href="#">HT3553: About the SD and SDXC card slot</a>. Card dimensions should be 32mm x 24mm x 2.1mm. Cards thicker than 2.1mm are too thick and may damage the card slot if inserted.</li><li>• While SDIO (Secure Digital Input Output) cards fit into and shouldn't damage card slot, they are not supported. SDXC cards are also unsupported.</li><li>• Fat 32 formatted SD cards are limited to 4GB. ExFAT formatted SD cards require Mac OS X 10.6.5 or later.</li><li>• MiniSD and Micro SD cards require adapters.</li></ul></li><li>5. For a more specific SD card type or format (Wireless-enabled SD card, other SD card) make sure that the correct driver is installed. Mac OS X supports only standard SD memory cards; other cards may require specific driver software.</li></ol>



## Deep Dive

Check	Result	Action	Code
1. Verify if SD card inserts correctly in SD slot.	Yes	Go to step 2.	
	No	Go to <a href="#">SD Memory Card Cannot Be Inserted Into Slot.</a>	
2. Unlock and insert user's SD card and verify it shows up on desktop or in System Profiler.	Yes	Go to step 6.	
	No	Go to step 3.	
3. Insert a known-good unlocked SD card and verify if read/write capabilities are working.	Yes	User's SD card not functioning properly. Contact card manufacturer for support.	
	No	Go to step 4.	
4. Run System Profiler and verify if SD card reader is now listed in USB devices.	Yes	Go to step 5.	
	No	Reseat SD cable at SD card reader and logic board	
		If issue persists, replace SD cable.	<b>X03</b>
	If issue persists after cable was replaced, replace SD card reader.	<b>X24</b>	
	If issue persists after card reader was replaced, replace logic board.	<b>M17</b>	
5. Verify if a known-good unlocked SD card can now be correctly read and written.	Yes	Go to step 6.	
	No	Replace SD card reader.	<b>X24</b>
6. Lock the user's SD card and verify if it can't be written.	Yes	Issue resolved.	
	No	Replace SD card reader.	<b>M17</b>



## Uncategorized Symptoms

Check	Result	Action	Code
1. Verify if existing symptom code applies to issue reported by user.	Yes	Jump to appropriate symptom code flow.	
	No	Document reported failure and send feedback to <a href="mailto:smfeedback6@apple.com">smfeedback6@apple.com</a> stating that a suitable symptom code wasn't found. Provide as much detail as possible.	<b>N99</b>



# Communications

## AirPort Issues

### Quick Check

Symptoms	Quick Check
<p><b>AirPort Issues</b></p> <ul style="list-style-type: none"> <li>• Unable to find or connect to wireless networks</li> <li>• Slow or stalled data transfers</li> <li>• Intermittent connection dropouts</li> <li>• AirPort cannot be enabled</li> <li>• AirPort card not available or recognized</li> </ul>	<p><b>Check on user's computer:</b></p> <ol style="list-style-type: none"> <li>1. Verify that AirPort is turned ON, and make sure that a network is selected.</li> <li>2. Use System Profiler to verify that installed AirPort card supports the channel number used by the wireless access point.</li> <li>3. Check for nearby sources of interference such as microwave ovens or cordless phones. See Apple Support article <a href="#">HT1365: AirPort and Bluetooth: Potential sources of wireless interference</a>.</li> <li>4. Check the number of users trying to use AirPort in the area for possible network congestion (available bandwidth).</li> <li>5. Check Apple Support article <a href="#">HT1159: Mac OS X versions (builds) included with Intel-based Macs</a> to make sure system build is correct for this computer model.</li> <li>6. Check for and apply the latest software and firmware updates.</li> <li>7. Isolate OS by starting up from known-good original system media or an up-to-date, bootable Mac OS X volume, a same-model computer in Target Disk Mode, or compatible known-good OS on an external drive. Both AirPort and Bluetooth services are available when booted from Install disc.</li> <li>8. In System Preferences &gt; Sharing &gt; Internet Sharing, configure a known-good computer to share its Ethernet connection to computers using AirPort. Try to connect user's computer to the newly created wireless network.</li> </ol> <p>(continued on next page)</p>



9. Using known-good OS & base station, compare AirPort throughput to a similar system using Activity Monitor > Network.
10. Reset PRAM by holding down Command-Option-P-R keys while rebooting, until you hear the startup sound for the second time.
11. Reset SMC: shut down computer, unplug power cord, press and hold power button for 5 seconds, release power button, and reconnect power cord.

**If issue cannot be reproduced, recommend user check his/her wireless base station:**

1. Check for base station firmware updates.
2. Check for nearby interference sources in the 2.4/5GHz range such as microwave ovens and cordless phones. See Apple Support article [HT1365: AirPort and Bluetooth: Potential sources of wireless interference](#).
3. Check that the base station is not using MAC address filtering or creating a hidden network.
4. Check that the base station is not set to low-power transmission mode.
5. Check that the base station is not using unsupported connection and encryption protocols.
6. Check for Wi-Fi channel overlap (a nearby base station using an adjacent channel).
7. Connect to a known-good test network.
8. Test in a different environment.

**Also see Apple Support article [HT1401: AirPort troubleshooting guide](#).**



## Deep Dive

Check	Result	Action	Code
1. Go to System Profiler > Network and verify if AirPort is recognized.	Yes	Install all available software updates for AirPort and retest. If issue persists after software update, go to step 4.	
	No	Go to step 2.	
2. Wait at least 15 seconds after computer has been shutdown and reseat AirPort card connection on logic board. Verify if AirPort card is now listed in System Profiler.	Yes	Issue resolved by reseating AirPort card.	
	No	Wait at least 15 seconds after computer has been shutdown and replace AirPort card and retest. Go to step 3.	<b>N01</b>
3. After AirPort card has been replaced, verify if AirPort card is now listed in System Profiler.	Yes	Issue resolved by replacing AirPort card.	
	No	Replace logic board. Retest.	<b>M11</b>
4. Enable AirPort and verify if known local AirPort networks are available, or create a computer-to-computer network with another Macintosh computer using AirPort. See <a href="http://docs.info.apple.com/article.html?path=AirPort/5.0/en/ap2110.html">http://docs.info.apple.com/article.html?path=AirPort/5.0/en/ap2110.html</a> . Verify if you connect successfully.	Yes	Issue resolved.	
	No	Go to step 5.	
5. Check and reseat the two antennas to the AirPort card. Verify if you can connect to known AirPort network.	Yes	Issue resolved.	
	No	Replace AirPort card. If issue persists, replace AirPort antenna(s). If the damaged antenna is embedded in rear housing behind Apple logo, replace rear housing.	<b>N04</b>  <b>X03</b>



## Bluetooth Issues

### Quick Check

Symptoms	Quick Check
<p><b>Bluetooth Issues</b></p> <ul style="list-style-type: none"><li>• Computer won't pair with Bluetooth keyboard, mouse or trackpad</li><li>• Slow or stalled data transfers over Bluetooth connection</li><li>• Intermittent Bluetooth connection dropouts</li></ul>	<ol style="list-style-type: none"><li>1. In System Preferences, make sure Bluetooth is on and set to Discoverable.</li><li>2. Install fresh or charged batteries in the Bluetooth device.</li><li>3. Move computer and Bluetooth device closer together.</li><li>4. Attempt to pair computer with a known-good Bluetooth keyboard or mouse.</li><li>5. Verify user's Bluetooth device with a known-good computer, using Apple Support article <a href="#">TS3048: Troubleshooting wireless mouse and keyboard issues</a>.</li><li>6. Reset Bluetooth device or delete pairing (if applicable).</li><li>7. Check Apple Support article <a href="#">HT1159: Mac OS X versions (builds) included with Intel-based Macs</a> to make sure system build is correct for this computer model.</li><li>8. Check for and apply the latest software and firmware updates.</li><li>9. If Bluetooth pairs normally at your service location, research potential sources of interference in the user's environment, such as microwave ovens or cordless phones in the 2.4/5GHz range. See Apple Support article <a href="#">HT1365: AirPort and Bluetooth: Potential sources of wireless interference</a>.</li><li>10. Isolate OS by starting up from known-good original system media or an up-to-date, bootable Mac OS X volume, a same-model computer in Target Disk Mode, or compatible known-good OS on an external drive. Both AirPort and Bluetooth services are available when booted from Install disc.</li></ol>



## Deep Dive

Check	Result	Action	Code
1. Verify that computer and known-good Bluetooth device are both in discoverable mode. Verify if you can now successfully and reliably pair the device.	Yes	Issue resolved.	
	No	If Bluetooth cannot be enabled, replace Bluetooth/camera cable. If issue persists replace Bluetooth board and retest. Go to step 3.	<b>X03</b>
		If Bluetooth can be enabled but Bluetooth communication persists, replace Bluetooth antenna. Go to step 2.	<b>X03</b>
2. Retest with new Bluetooth antenna and verify if Bluetooth issues are resolved.	Yes	Issue resolved.	
	No	Replace Bluetooth board.	<b>N15</b>
3. Retest with new Bluetooth cable/card and verify if Bluetooth issues are resolved.	Yes	Issue resolved.	
	No	Replace logic board.	<b>M11</b>



## AirPort Card Kernel Panic

### Quick Check

Symptoms	Quick Check
<b>AirPort Card Kernel Panic</b> <ul style="list-style-type: none"> <li>Kernel panic on startup</li> <li>Kernel panic or freezing while attempting to connect to Wi-Fi networks</li> <li>Kernel panic while transferring data on Wi-Fi networks</li> </ul>	<ol style="list-style-type: none"> <li>Isolate OS by starting up from original Install media for this computer, a same-model computer in Target Disk Mode, or compatible known-good OS on an external drive. AirPort and Bluetooth services are available when booted from the Install disk.</li> <li>Check for and apply the latest software and firmware updates.</li> </ol>

### Deep Dive

Check	Result	Action	Code
<ol style="list-style-type: none"> <li>Wait at least 15 seconds after computer has been shutdown before disconnecting AirPort card from logic board. Verify if computer now starts without kernel panic.</li> </ol>	Yes	Reseat AirPort card and retest. If problem continues replace AirPort card. Go to step 2.	
	No	Kernel panic not related to AirPort. Restart from Install DVD or known-good bootable external drive and check Panic.Log file on user's hard drive to find out which is the crashing I/O interface. Also troubleshoot installed Mac OS X software.	
<ol style="list-style-type: none"> <li>With replacement AirPort card installed, verify if computer starts now without kernel panic.</li> </ol>	Yes	AirPort card issue. Issue resolved.	<b>N13</b>
	No	Replace logic board.	<b>M11</b>



## Ethernet Issues

Unlikely cause: LCD panel, power supply, hard drive, optical drive, fans

### Quick Check

Symptoms	Quick Check
<b>Ethernet Issues</b> <ul style="list-style-type: none"><li>• No Ethernet device present</li><li>• Unable to access network resources</li><li>• Ethernet device shows no connection</li><li>• Ethernet device unable to an IP address</li><li>• Slow network performance</li></ul>	<ol style="list-style-type: none"><li>1. Check Ethernet cable for damage. Try a known good Ethernet cable – CAT5 or better recommended for 100Mbps+ connections.</li><li>2. Check Ethernet ports on the computer and wall/switch for dust, debris, damage or bent pins.</li><li>3. Ensure distance from networking infrastructure is less than 300 feet/ 105 meters.</li><li>4. Verify port, cable and network hardware with a known good system. Isolate firewall, MAC address filtering or hardware access control devices.</li><li>5. Isolate OS by starting up from original Install media for this computer, a same-model computer in Target Disk Mode, or compatible known-good OS on an external drive.</li><li>6. Using known-good network hardware and cable, start up from known-good Mac OS X volume. Go to Network Utility &gt; Info and verify that the Link Status is “Active.”</li><li>7. Check network settings. If a known-good DHCP server is available, set System Preferences &gt; Network &gt; Ethernet to “Using DHCP” and verify IP address. (If it starts with 169.x.x.x, the system was unable to get a valid IP address.)</li><li>8. When started from user’s OS, revert to default network settings by creating a new location in System Preferences &gt; Network.</li></ol>



## Deep Dive

Check	Result	Action	Code
1. Visually inspect Ethernet port of computer and ensure that all pins will make physical contact with the Ethernet cable.	Yes	Go to step 2.	
	No	Pins are damaged, bent flat or missing. Replace logic board.	<b>M24</b>
2. Boot from original Install media. Verify Network Link status is active by using Network Utility under the "Info" tab. Verify if the Link Status is "Active".	Yes	Go to step 3.	
	No	If same Ethernet cable gives an "Active" link status on a known-good, same-model computer, replace logic board.	<b>M10</b>
3. Connect computer to another Mac using CAT5 Ethernet cable. See article <a href="http://docs.info.apple.com/article.html?path=Mac/10.6/en/8429.html">http://docs.info.apple.com/article.html?path=Mac/10.6/en/8429.html</a> . Verify if you connect successfully.	Yes	Ethernet communication good. Go to step 4.	
	No	If same Ethernet cable and computer connects to a known-good, same-model computer, replace logic board.	<b>M10</b>
4. Check for speed and duplex issues on network. Open System Preference > Network; click the Advanced button, then the Ethernet tab. Verify if the speed and duplex reported are what is expected.	Yes	Go to step 5.	
	No	Change speed and duplex settings. See article <a href="http://docs.info.apple.com/article.html?path=Mac/10.6/en/8711.html">http://docs.info.apple.com/article.html?path=Mac/10.6/en/8711.html</a> . Go to step 6.	
5. Check for MTU (Maximum Transmission Unit) issues. See Apple Support article <a href="#">HT2532: Mac OS X 10.4 or later: How to change the MTU for troubleshooting purposes</a> . Verify if changing MTU settings on computer resolves issue.	Yes	Go to step 6.	
	No	Ethernet controller damaged. Replace logic board.	<b>M10</b>
6. If changing speed, duplex or MTU settings allows connectivity, check with a known-good, same-model computer. Verify if known-good computer produces the same results.	Yes	Check with ISP or Network Administrator concerning speed, duplex & MTU settings.	
	No	Verify with known good OS. If issue persists, replace logic board.	<b>M10</b>



## Wireless Input Device Does Not Pair

### Quick Check

Symptoms	Quick Check
<p><b>Wireless Input Device Doesn't Pair</b></p> <ul style="list-style-type: none"> <li>Computer does not recognize a Bluetooth keyboard, mouse or trackpad</li> </ul>	<ol style="list-style-type: none"> <li>Restart computer.</li> <li>Check computer with a known-good Bluetooth input device to test computer side.</li> <li>Test Bluetooth device side with a known-good, up-to-date computer with installed Bluetooth device driver.</li> <li>Ensure that device is being used within 30-foot range for Bluetooth devices.</li> <li>See Apple Support article <a href="#">TS3048: Troubleshooting wireless mouse and keyboard issues</a>.</li> </ol>

### Deep Dive

Check	Result	Action	Code
1. Without any wired input devices connected, and with a known-good Apple wireless mouse /trackpad in discoverable mode, startup the computer. Verify if computer shows the Bluetooth Mouse Setup Assistant.	Yes	Bluetooth hardware is active. Go to step 6.	
	No	Go to step 2.	
2. Connect a wired mouse and run System Profiler. Verify if Bluetooth interface is listed under USB in System Profiler.	Yes	Bluetooth hardware is present. Go to step 6.	
	No	Remove glass and LCD panel, reseal both ends of cable between Bluetooth board and logic board. Go to step 3.	
3. Using an externally connected display, run System Profiler and verify if Bluetooth interface is listed under USB in System Profiler.	Yes	Bluetooth hardware is now present. Go to step 6.	
	No	Replace Bluetooth cable. Go to step 4.	<b>X03</b>
4. Run System Profiler. Verify if Bluetooth interface is listed under USB in System Profiler.	Yes	Bluetooth hardware is now present. Go to step 6.	
	No	Replace Bluetooth board. Go to step 5.	<b>N15</b>



5. Run System Profiler. Verify if Bluetooth interface is listed under USB in System Profiler.	Yes	Bluetooth hardware is now present. Go to step 6.	
	No	Replace logic board.	<b>M11</b>
6. Run Software Update and apply any available Bluetooth updates. Activate Bluetooth in System Preferences (or Apple menu icon) then select "Configure a new Bluetooth device" (or run Bluetooth Mouse Setup Assistant). Verify if a known-good Bluetooth mouse/trackpad is seen.	Yes	Bluetooth discovery is now active. Go to step 7.	
	No	Replace Bluetooth antenna.	<b>X03</b>
7. With a known-good Apple Wireless mouse/trackpad on and in discoverable mode, verify if you can successfully pair the device with the assistant.	Yes	Check for stability. Go to step 8.	
	No	Go to <a href="#">Wireless Input Device Loses Connection</a> .	
8. With known-good Apple Wireless mouse/trackpad paired, verify if the device stays connected.	Yes	Issue resolved.	
	No	Inspect and reseal Bluetooth antenna cable. Replace a damaged antenna cable, or Bluetooth board if its antenna connector is damaged. Go to step 9.	<b>X03</b>
9. With user's mouse/trackpad paired, verify if the mouse stays connected.	Yes	Antenna issue. Issue resolved. Resassemble system.	
	No	Go to <a href="#">Wireless Input Device Loses Connection</a> .	



## Uncategorized Symptoms

### Quick Check

Symptoms	Quick Check
<b>Uncategorized Symptoms</b> <ul style="list-style-type: none"> <li>Unable to locate appropriate symptom code.</li> </ul>	<ol style="list-style-type: none"> <li>Verify System Preferences/Network settings are configured appropriately to support communication method.</li> <li>For Ethernet connection issues verify that cable being used functions when used with another known-good system.</li> <li>For wireless connection issues review user environment to determine whether possible interference from other 2.4GHz communications devices might be contributing to issue. See Apple Support article <a href="#">HT1365: AirPort and Bluetooth: Potential sources of wireless interference.</a></li> </ol>

### Deep Dive

Check	Result	Action	Code
1. Verify if existing symptom code applies to issue reported by user.	Yes	Jump to appropriate symptom code flow.	
	No	Document reported failure and send feedback to <a href="mailto:smfeedback6@apple.com">smfeedback6@apple.com</a> stating that a suitable symptom code wasn't found. Provide as much detail as possible.	<b>N99</b>



# Input/Output Devices

## Apple Remote Issues

Unlikely cause: LCD panel, power supply, hard drive, optical drive, fans

### Quick Check

Symptoms	Quick Check
<p><b>Apple Remote Issues</b></p> <ul style="list-style-type: none"><li>• Apple Remote doesn't bring up Front Row</li><li>• Apple Remote doesn't control iTunes</li><li>• Apple Remote doesn't control computer volume</li><li>• Apple Remote is not recognized</li></ul>	<ol style="list-style-type: none"><li>1. Make sure computer is on, awake and the IR window (front Apple logo) is clean.</li><li>2. Make sure:<ul style="list-style-type: none"><li>• the lens end of the Apple Remote is pointing directly at front of computer.</li><li>• the Apple Remote has an unobstructed line-of-sight to computer.</li><li>• the Apple Remote is within 30 ft. of computer.</li></ul></li><li>3. In System Preferences &gt; Security &gt; General, verify that "Disable remote control infrared receiver" is not checked. If "Unpair" button is active, press it and try to pair again with the Apple Remote. See Apple Support article <a href="#">HT1619: Pairing your Apple Remote with your computer</a>.</li><li>4. Facing a known-good computer, press both the 'Menu' and 'Next' buttons on the remote for five seconds to try to pair it.</li><li>5. Repeat previous step with a known-good remote facing user's computer. (Remote should be used within 30 feet of the computer and have an unobstructed line-of-sight to the IR window.)</li><li>6. Reset PRAM by holding down Command-Option-P-R keys while rebooting, until you hear the startup sound for the second time.</li><li>7. Reset SMC: shut down computer, unplug power cord, press and hold power button for 5 seconds, release power button, and reconnect power cord.</li><li>8. Check for and apply the latest software and firmware updates.</li></ol>



## Deep Dive

Check	Result	Action	Code
1. Open Photo Booth or iChat's video preview window. Point Apple Remote at built-in camera and press any button on Apple Remote. Verify if a white, flashing light is visible in video preview.	Yes	Apple Remote is functioning. Go to step 2.	
	No	Replace Apple Remote battery. Go to step 3.	
2. Open System Preferences > Security. Verify if "Unpair" setting is available in this preference panel.	Yes	Click "Unpair" button to disable possible pairing with another Apple Remote. Go to step 4.	
	No	Possible IR board issue. Go to step 5.	
3. With replacement battery, verify if white flashing light is visible coming from Apple Remote in video preview window.	Yes	Battery issue. Issue resolved.	<b>X05</b>
	No	Apple Remote defective. Replace Apple Remote.	<b>X04</b>
4. After clicking "Unpair," verify if the computer now responds to the Apple Remote.	Yes	Pairing issue. Issue resolved.	
	No	Possible IR board issue. Go to step 5.	
5. Open System Profiler. Verify if "IR Receiver" is listed in USB list of devices.	Yes	IR board reporting on USB bus. Check for lens block. Go to step 6.	
	No	Inspect and reseal IR cable connection to logic board. Go to step 7.	
6. Check that IR board is correctly fitted and aligned with Apple window and that lens is not blocked by any foreign material and re-test. Verify if computer responds to Apple Remote.	Yes	Lens blocked or sensor not aligned with window. Issue resolved.	<b>X03</b>
	No	Lens damaged or inoperable. Replace IR board. Go to step 7.	
7. After reseating or replacing IR board, verify if "IR Receiver" is listed under USB in System Profiler, and that computer now responds to Apple Remote.	Yes	IR module reseated/replaced. Issue resolved.	<b>X03</b>
	No	If IR board was only reseated, replace IR cable. Go to step 8.	



8. After replacing IR cable, verify if "IR Receiver" is listed under USB in System Profiler, and that computer now responds to Apple Remote.	Yes	IR cable replaced. Issue resolved.	<b>X03</b>
	No	Replace IR board. Go to step 9.	
9. After replacing IR board, verify if "IR Receiver" is listed under USB in System Profiler, and that computer now responds to Apple Remote.	Yes	IR board replaced. Issue resolved.	<b>X03</b>
	No	Replace logic board.	<b>M23</b>

## Microphone Issues

Unlikely cause: LCD panel, power supply, hard drive, optical drive, fans

### Quick Check

Symptoms	Quick Check
<b>Microphone Issues</b> <ul style="list-style-type: none"> <li>• Microphone not working</li> <li>• Microphone audio garbled</li> <li>• No sound</li> </ul>	<ol style="list-style-type: none"> <li>1. Verify that no tape, sticky notes, or other objects are blocking microphone located on top of computer near camera. Microscopic perforations on top of computer must be free of obstructions in order for microphone to function.</li> <li>2. Go to System Preferences &gt; Sound &gt; Input. Verify that sound input device is set to internal microphone.</li> <li>3. Go to System Preferences &gt; Sound &gt; Input. Verify that "Input volume" setting is set above minimum level.</li> <li>4. Go to System Preferences &gt; Sound &gt; Input. Verify that "Input level" indicator moves when speaking into microphone.</li> </ol>



## Deep Dive

Check	Result	Action	Code
1. Verify if startup sound is present when system is powered ON. Make sure audio output preferences are not set to mute.	Yes	Go to step 2.	
	No	Reset PRAM and retest.	
2. Make sure no cables are connected to external sound input/output ports. Go to System Preferences > Sound > Input and verify that "Internal microphone" is an available option.	Yes	Go to step 3.	
	No	Replace audio cable.	<b>M09</b>
3. Go to System Preferences > Sound > Input and verify if "Input volume" is set above minimum sensitivity.	Yes	Go to step 4.	
	No	Set "Input volume" slider to middle position. Retest.	
4. Go to System Preferences > Sound > Input and verify if "Input level" indicator moves when speaking into microphone.	Yes	Microphone and audio input functioning. Go to step 6.	
	No	Suspect bad microphone connection. Reseat microphone connector on logic board. Go to step 5.	
5. Inspect microphone cable routing and verify if cable is pinched or damaged.	Yes	Replace rear housing (microphone cable not available separately).	<b>L14</b>
	No	Go to step 6.	
6. Record sound sample using GarageBand or iMovie. Verify if sound quality of sound sample is normal during playback.	Yes	Microphone circuitry OK. Return system to user.	
	No	Replace logic board.	<b>M09</b>



## Distorted Audio From Internal Speaker(s)

Unlikely cause: LCD panel, power supply, hard drive, optical drive, fans

### Quick Check

Symptoms	Quick Check
<b>Distorted Audio From Internal Speaker(s)</b> <ul style="list-style-type: none"> <li>No audio from one or both speakers.</li> <li>Audio from speakers distorted</li> </ul>	<ol style="list-style-type: none"> <li>Go to System Preferences &gt; Sound &gt; Output. Verify that sound output device is set to internal speakers and that balance control is set to the center position.</li> <li>Obtain known-good high-quality sound file or use iTunes Store sound samples to evaluate sound quality. Verify suspect sound files on another system to determine if distortion is caused by computer or sound file.</li> <li>Set volume control to mid-range. Overdriving built-in speakers can cause distortion.</li> <li>If testing using iTunes, make sure both the equalizer and preamp settings are set to the "Flat" setting.</li> <li>Test audio output using another application or website.</li> <li>Reset PRAM by holding down Command-Option-P-R keys while rebooting, until you hear the startup sound for the second time.</li> </ol>

### Deep Dive

Check	Result	Action	Code
<ol style="list-style-type: none"> <li>Go to System Preferences &gt; Sound &gt; Output. Set speaker balance 100% to LEFT speaker and play a known-good sound file. Verify if sound is generated by LEFT speaker and that sound quality is acceptable.</li> </ol>	Yes	LEFT speaker and amplifier circuitry OK. Go to step 2.	
	No	Distortion detected in LEFT speaker. Set Balance slider to middle position. Go to step 3.	
<ol style="list-style-type: none"> <li>Set speaker balance 100% to RIGHT speaker and play a known-good sound file. Verify if sound is generated by RIGHT speaker and that sound quality is acceptable.</li> </ol>	Yes	RIGHT speaker and amplifier circuitry OK. Set Balance slider to middle. Go to step 3.	
	No	Distortion detected in RIGHT speaker. Go to step 4.	



3. Connect external speakers or headphones to audio-out port and play a known-good sound file. Verify if sound quality is acceptable.	Yes	Suspect bad speaker. Go to step 4.	
	No	Audio CODEC or amplifier issue suspected. Replace logic board and retest.	<b>M09</b>
4. Inspect LEFT and RIGHT speakers for damage or <u>loose screws</u> attached to speaker cone. Inspect the speaker cable for damage. Verify whether speakers have visible damage.	Yes	Replace damaged speaker. Retest.	<b>L11</b>
	No	Go to step 5.	
5. Install known-good speaker into location where distorted sound was heard. Verify if sound quality improves.	Yes	Replace speaker.	<b>L11</b>
	No	Speaker amplifier issue suspected. Replace logic board.	<b>M09</b>

## No Audio From Internal Speaker(s)

Unlikely cause: LCD panel, power supply, hard drive, optical drive, fans

### Quick Check

Symptoms	Quick Check
<b>No Audio From Internal Speaker(s)</b> <ul style="list-style-type: none"> <li>No audio from one or both speakers.</li> </ul>	<ol style="list-style-type: none"> <li>Confirm correct version of Mac OS X is installed. See Apple Support article <a href="#">TS1574: Troubleshooting issues with no audio from built-in speakers on Macs</a>.</li> <li>Go to System Preferences &gt; Sound &gt; Output. Verify that sound output device is set to internal speakers.</li> <li>Go to System Preferences &gt; Sound &gt; Output. Verify that “Output volume” setting is set above the minimum level and that “Mute” checkbox is not selected.</li> <li>Go to System Preferences &gt; Sound &gt; Output. Verify that “Balance” slider is set to middle position so left and right speakers are both used.</li> </ol>



## Deep Dive

Check	Result	Action	Code
1. Verify if startup sound is present when computer is powered ON. Make sure audio output preferences are not set to mute and volume is set to mid-range.	Yes	Go to step 2.	
	No	Reset PRAM and retest.	
2. Make sure no cables are connected to external sound input/output ports. Go to System Preferences > Sound > Output and verify that "Internal speakers" is an available option.	Yes	Go to step 3.	
	No	If "Headphones" is the only available sound output device, replace audio cable.	L11
	No	If "Digital output" is the only available sound output device, reseal audio cable to logic board. If issue persists, replace audio cable.  If issue persists, replace logic board.	L11  M09
3. Go to System Preferences > Sound > Output. Set speaker balance 100% to LEFT speaker and play a known-good sound file. Verify if sound is generated by LEFT speaker and that sound quality is acceptable.	Yes	LEFT speaker and amplifier circuitry OK. Go to step 4.	
	No	No audio in LEFT speaker. Go to step 7.	
4. Set speaker balance 100% to RIGHT speaker and play a known-good sound file. Verify if sound is generated by RIGHT speaker and that sound quality is acceptable.	Yes	RIGHT speaker and amplifier circuitry OK. Set Balance slider to middle. Go to step 5.	
	No	No audio in RIGHT speaker. Go to step 7.	
5. Verify if user-reported audio issue has been resolved.	Yes	Issue no longer present. Return computer to user.	
	No	Go to step 6.	
6. Start up from known-good original system media or an up-to-date, bootable Mac OS X volume and verify whether issue still occurs.	Yes	Go to step 7.	
	No	Known-good boot volume works OK. Troubleshoot for software issue. Isolate if issue is application-specific or a possible OS conflict.	



7. Connect external speakers or headphones to audio-out port and play a known-good sound file. Verify if sound quality is acceptable.	Yes	Logic board, internal speakers, and audio-out port functioning correctly. Return system to user.	
	No	Go to step 8.	
8. Disconnect and carefully inspect audio connectors assembly and its connection to logic board for damage such as bent pins or pinched/cut wires.	Yes	Replace damaged audio connectors assembly. If issue persists, verify if symptom has changed.	<b>L14</b>
	No	Replace logic board.	<b>M09</b>

## Camera Issues

Unlikely cause: LCD panel, power supply, hard drive, optical drive, fans, speakers

### Quick Check

Symptoms	Quick Check
<b>Camera Issues</b> <ul style="list-style-type: none"> <li>• Camera not detected</li> <li>• No green LED for camera</li> <li>• Excessive blooming</li> <li>• Poor White Balance</li> <li>• Poor Focus</li> <li>• Green image</li> <li>• Image distortion</li> </ul>	<ol style="list-style-type: none"> <li>1. Launch System Profiler and confirm that computer's USB hub and built-in camera are visible.</li> <li>2. Verify camera lens and glass panel are clean and free of contaminants. Clean glass panel if needed.</li> <li>3. Launch Photo Booth to verify that green indicator LED near camera lens turns on and image quality is acceptable.</li> <li>4. Ask user about lighting conditions in their environment. Dim lighting contributes to poor image quality. Overly bright light can reflect off surfaces onto the subject, creating a foggy image.</li> <li>5. Striped or mesh clothing or textures can cause moiré patterns in the image.</li> <li>6. Disconnect all external USB devices and check if camera begins to operate.</li> <li>7. Reset PRAM by holding down Command-Option-P-R keys while rebooting, until you hear the startup sound for the second time.</li> <li>8. Reset SMC: shut down computer, unplug power cord, press and hold power button for 5 seconds, release power button, and reconnect power cord.</li> <li>9. Check for and apply the latest software and firmware updates.</li> </ol>



## Deep Dive

Check	Result	Action	Code
1. Launch System Profiler and verify built-in camera is visible in USB list of devices.	Yes	Camera recognized. Go to step 2	
	No	Inspect and reseat camera cable connection on logic board. Go to step 2.	
2. Launch Photo Booth. Verify if green LED near camera lens turns ON and image appears normal.	Yes	Camera functioning. Return system to user.	
	No	Remove glass and clean both sides. Clean camera lens.	
		If issue persists, replace camera cable.	<b>X03</b>
	If issue persists, replace camera.	<b>X21</b>	
	If issue persists, replace logic board.	<b>M13</b>	

## FireWire Port Does Not Recognize Devices

Unlikely cause: LCD panel, power supply, hard drive, optical drive, fans

### Quick Check

Symptoms	Quick Check
<b>FireWire Port Does Not Recognize Devices</b> <ul style="list-style-type: none"> <li>• FireWire hard drive not recognized</li> <li>• FireWire optical drive not recognized</li> <li>• FireWire camera not recognized</li> <li>• FireWire printer not recognized</li> </ul>	<ol style="list-style-type: none"> <li>1. For FireWire drives, make sure any external power source is plugged in and operating to isolate a power issue with the device.</li> <li>2. Test a known-good FireWire device to isolate a failed peripheral issue.</li> <li>3. Test a known-good FireWire cable to isolate a cable issue.</li> <li>4. Check for and apply the latest software and firmware updates.</li> <li>5. Launch System Profiler and verify if the affected FireWire device is visible on FireWire bus. If yes, then FireWire port and cable are functioning properly. Contact FireWire device manufacturer to verify that device is supported.</li> </ol>



## Deep Dive

Check	Result	Action	Code
1. Unplug all FireWire devices from computer. Reset PRAM. Reconnect FireWire device in question. Verify if FireWire device is recognized.	Yes	Issue resolved.	
	No	Possible logic board failure. Go to step 2.	
2. Use a known-good FireWire cable with a known-good FireWire device (such as another Mac in Target Disk Mode). Verify if FireWire device is recognized.	Yes	Try FireWire device in question with a known-good computer of same model. Go to step 3.	
	No	FireWire not recognized. Replace logic board.	<b>M12</b>
3. Verify if FireWire device is recognized on a known-good same model computer.	Yes	Go to step 4.	
	No	Device may need additional power. Use a powered FireWire hub. Go to step 5.	
4. Verify if FireWire device is recognized with a known-good FireWire cable on user's computer.	Yes	FireWire cable issue. Issue resolved.	
	No	FireWire device may need additional power. Go to step 5.	
5. Using a powered FireWire hub, and having installed any software or firmware updates for the device, verify if FireWire device is now recognized.	Yes	Device recognized. Required additional power from hub or update. Issue resolved.	
	No	Device may require additional software, or there may be a conflict in the Mac OS. Go to step 6.	
6. Create a new user in System Preferences > Accounts and log out current user. Log in on new user account and verify if FireWire device is now recognized.	Yes	Software Issue. Troubleshoot software on User account. Issue resolved.	
	No	Apply all Mac OS and FireWire specific updates. If issue persists, contact device manufacturer for support. FireWire port and cable have been verified.	



## USB Port Not Recognized

Unlikely cause: LCD panel, power supply, hard drive, optical drive, fans

### Quick Check

Symptoms	Quick Check
<b>USB Port Not Recognized</b> <ul style="list-style-type: none"> <li>• USB wired keyboard/mouse not recognized</li> <li>• USB external drive not recognized</li> <li>• USB camera not recognized</li> <li>• USB printer not recognized</li> </ul>	<ol style="list-style-type: none"> <li>1. Reset SMC: shut down computer, unplug power cord, press and hold power button for 5 seconds, release power button, and reconnect power cord.</li> <li>2. For printers and external USB drives, make sure any external power source is plugged in and operating to isolate a power issue with device.</li> <li>3. The iMac has 4 USB ports on rear of computer. Try each port to isolate a particular port malfunction.</li> <li>4. Test with a known-good wired keyboard or mouse to isolate a failed peripheral issue.</li> <li>5. Test with a known-good USB cable when dealing with a printer or external USB drive, to isolate a USB cable issue.</li> <li>6. Check for and apply the latest software and firmware updates.</li> <li>7. Launch System Profiler and verify if device is visible on USB bus. If yes, then the USB port and cable are functioning properly. Contact device manufacturer to verify that device is supported.</li> </ol>

### Deep Dive

Check	Result	Action	Code
1. Unplug all USB devices from the computer except for USB keyboard and mouse. Start computer and reset PRAM. Verify if USB keyboard and mouse are recognized.	Yes	Test with all USB ports to ensure all USB ports working as expected. Replace logic board for any port failures.	
	No	Reset SMC. Go to step 2.	
2. Verify if Bluetooth Mouse Setup assistant launches after startup.	Yes	Bluetooth detected, but external USB devices not recognized. Go to step 3.	
	No	Disconnect USB keyboard and mouse. Go to step 4.	



3. Verify if a known-good USB keyboard and mouse are recognized.	Yes	Test original USB mouse and keyboard. Replace if still not recognized. Go to step 5.	
	No	External USB ports not functioning. Replace logic board.	<b>M15</b>
4. With no USB devices connected, restart computer. Verify if Bluetooth Mouse Setup assistant launches after startup.	Yes	Bluetooth detected. Go to step 3.	
	No	Bluetooth not recognized. Internal and external USB not functioning. Replace logic board.	<b>M15</b>
5. With known-good USB keyboard and mouse working, test USB peripheral in question (USB hard drive or printer, etc.) Verify if device is recognized in System Profiler > USB.	Yes	Device recognized. Test in all USB ports to ensure all USB ports working as expected. Replace logic board for any port failures.	<b>M15</b>
	No	Device may require more power than supplied by USB ports. Test with a powered USB hub. Go to step 6.	
6. Verify if using a powered USB hub resolves the issue.	Yes	Test device on the same USB port of a same-model computer without any other USB port populated. If other computer does not require a powered USB hub to allow the device functionality, replace logic board.	<b>M15</b>
	No	The computer's USB ports and cable have been verified. Check for and apply the latest software and firmware updates. for computer and device. If issue persists, contact device manufacturer for support.	



## Wired Keyboard Does Not Work Properly

### Quick Check

Symptoms	Quick Check
<p><b>Wired Keyboard Does Not work Properly</b></p> <ul style="list-style-type: none"> <li>Some or all keys on the keyboard don't work</li> <li>Eject key or Caps Lock key doesn't seem to work</li> <li>Some keys don't work as expected</li> </ul>	<ol style="list-style-type: none"> <li>Reset SMC: shut down computer, unplug power cord, press and hold power button for 5 seconds, release power button, and reconnect power cord.</li> <li>Open System Preferences &gt; Universal Access &gt; Mouse &amp; Trackpad and verify that Mouse Keys is turned OFF. When enabled, Mouse Keys can disable functionality of some or most keys, depending on keyboard used.</li> <li>The iMac has 4 USB ports on rear of computer. Make sure to try each port to isolate a particular port malfunction.</li> <li>Test with a known-good wired keyboard to isolate a failed peripheral issue.</li> <li>Test wired keyboard on a known-good, same-model computer. If it works on the other computer, this may indicate a bad USB port if keyboard doesn't work at all on user's computer, or a software issue if keyboard is working but not as expected on user's computer.</li> <li>Check for and apply the latest software and firmware updates.</li> </ol>

### Deep Dive

Check	Result	Action	Code
1. Verify if all keys on keyboard work.	Yes	Go to step 2.	
	No	Go to <a href="#">Keyboard: Specific Keys Do Not Respond</a> .	
2. Verify if Caps Lock is working as expected.	Yes	Go to step 3.	
	No	Go to <a href="#">Keyboard: Specific Keys Do Not Respond</a> .	
3. Verify if media Eject key is working as expected. Note that to prevent accidentally ejecting media, Mac OS X adds a slight delay to the media Eject key before it takes effect.	Yes	Go to step 4.	
	No	Go to step 5.	



4. Open System Preferences > Speech. Verify if the "Speak selected text when the key is pressed" checkbox is selected.	Yes	The key combination to speak text cannot be used for any other purpose. Either disable, or change to a more rare key combination (including Shift, Command, Option and Control).	
	No	Go to step 6.	<b>M15</b>
5. With optical media in the drive, hold the media Eject key. Verify if the eject symbol appears on screen and that optical media is ejected if present.	Yes	Normal media eject key delay. No repair necessary.	
	No	Go to <a href="#">Optical Drive Rejects or Does Not Accept Media.</a>	
6. Open System Preferences > Language and Text > Input Menu. Check "Keyboard Viewer". From the Input Menu (flag) in the Menu Bar, choose "Show Keyboard Viewer". Verify if keys pressed appear in Keyboard Viewer.	Yes	Keys recognized. Go to step 9.	
	No	Keys not recognized. Replace keyboard.	<b>K01</b>
7. Open TextEdit or another text application and try typing something using the non-responding keys. Verify if they are typed in this other application.	Yes	Application-specific issue. Troubleshoot application.	
	No	Create a new user account in System Preferences > Accounts, log out from current user and log in with new user to isolate a User account related issue. If issue persists, reinstall Mac OS X from Install DVD.	



## Keyboard: Specific Keys Do Not Respond

### Quick Check

Symptoms	Quick Check
<p><b>Keyboard: Specific Keys Do Not Respond</b></p> <ul style="list-style-type: none"> <li>• One or more keys do not respond when pressed</li> <li>• Key sticks</li> <li>• Keycap missing</li> </ul>	<ol style="list-style-type: none"> <li>1. If wireless keyboard is being used verify that it is properly paired with computer. Go to <a href="#">Wireless Input Device Does Not Pair</a> symptom flow to resolve pairing issues.</li> <li>2. The caps lock key has a built-in delay to reduce accidental activation and must be held for approximately ½ second for it to be activated. See Apple Support article <a href="#">TS1578: Keyboard Caps Lock modified to reduce accidental activation</a>.</li> <li>3. Inspect keyboard for signs of liquid spills or other contamination. Apple's warranty does not cover accidental damage.</li> <li>4. If keycap is loose attempt to reattach it.</li> <li>5. Use the Keyboard Viewer menu to check every key.</li> <li>6. Recheck keyboard with a known-good computer with an up-to-date version of Mac OS X.</li> <li>7. Replace keyboard if issue is confirmed (K01 for inoperative keys, K17 for wrong/falling keycaps).</li> </ol>

## Wired Keyboard/Mouse Not Recognized

### Quick Check

Symptoms	Quick Check
<p><b>Wired Keyboard/Mouse Not Recognized</b></p> <ul style="list-style-type: none"> <li>• USB wired keyboard/mouse not recognized when plugged in.</li> <li>• Mouse scroll ball not working or not working as expected.</li> <li>• Mouse buttons not working or not working as expected.</li> </ul>	<ol style="list-style-type: none"> <li>1. Reset SMC: shut down computer, unplug power cord, press and hold power button for 5 seconds, release power button, and reconnect power cord.</li> <li>2. The iMac has 4 USB ports on rear of computer. Make sure to try each port to isolate a particular port malfunction.</li> <li>3. Test with a known-good wired keyboard or mouse to isolate a failed peripheral issue.</li> <li>4. Test a mouse when connected directly to ports on the back of iMac to isolate a keyboard USB port issue.</li> <li>5. Check for and apply the latest software and firmware updates.</li> </ol>



## Deep Dive

Check	Result	Action	Code
1. Verify if computer recognizes keyboard or mouse when plugged into rear USB ports on back of iMac.	Yes	Test device in all USB ports to ensure all other USB ports are working as expected.  Replace logic board if any USB port on rear fails.  Replace keyboard if any USB port on keyboard fails.  Go to step 2.	M15  K11
	No	Go to <a href="#">USB Port Not Recognized</a> .	
2. Verify if keyboard is working as expected.	Yes	Go to step 3.	
	No	Go to <a href="#">Wired Keyboard Does Not Work Properly</a> .	
3. Verify if Mighty Mouse has an issue with scroll ball.	Yes	See Apple Support article <a href="#">HT3226: How to clean Apple products</a> .	
	No	Go to step 4.	
4. Verify if mouse has an issue with buttons.	Yes	Go to step 7.	
	No	Go to step 5.	
5. Verify if mouse has an issue with tracking.	Yes	Go to step 6.	
	No	Go to step 7.	
6. Try using mouse on another surface. Non-reflective, opaque surfaces without repetitive patterns work best. The surface should be clean but not shiny. Verify if mouse tracks correctly when used on another surface.	Yes	Surface issue. Issue resolved.	
	No	Go to step 7	
7. See Apple Support article <a href="#">HT1581: Troubleshooting Mighty Mouse and determining expected behavior</a> . Verify if this article resolves issue.	Yes	Issue resolved.	
	No	Replace wired Mighty Mouse.	K99



## Wireless Input Device Does Not Pair

### Quick Check

Symptoms	Quick Check
<p><b>Wireless Input Device Does Not Pair</b></p> <ul style="list-style-type: none"><li>• Apple Wireless Keyboard/Magic Mouse/Magic Trackpad not recognized when powered on.</li><li>• Unable to pair Bluetooth input device with computer.</li><li>• Apple Magic Mouse buttons not working.</li><li>• Apple Magic Trackpad clicking/tracking/tapping actions not working.</li></ul>	<ol style="list-style-type: none"><li>1. Remove/ reinstall batteries into device to check they were not reversely inserted.</li><li>2. Check for and apply the latest software and firmware updates.</li><li>3. Ensure that the Bluetooth device software has been installed on test computer.</li><li>4. Install known-good charged batteries in Bluetooth device. Press power button to check that green LED stays lit for at least 3 seconds.</li><li>5. Refer to Apple Support article <a href="#">TS3048: Troubleshooting wireless mouse and keyboard issues</a>.</li><li>6. Use a known-good up-to-date Mac OS X computer with Bluetooth enabled, where a known-good similar Bluetooth device could be previously paired, and where a wired mouse is connected.</li><li>7. Try to pair the affected Bluetooth device using the Bluetooth Setup Assistant Utility.</li><li>8. (Apple Wireless Keyboard , Magic Mouse or Magic Trackpad) Download and run Bluetooth Service Diagnostic (BSD).</li><li>9. (Apple Wireless Keyboard , Magic Mouse or Magic Trackpad) After BSD tests passed, pair the device again, using the Bluetooth Setup Assistant.</li></ol>



## Deep Dive

Check	Result	Action	Code
1. (Apple Wireless Keyboard, Magic Mouse, Magic Trackpad) With known-good charged batteries and known-good up-to-date Mac OS X computer with the Bluetooth device software installed, run BSD and verify that all tests pass.	Yes	Go to step 2.	
	No	Replace defective Bluetooth device specifying the code provided by BSD or corresponding symptom code: -does not connect -no LED when turned on -click does not work -cursor jumpy, jittery -intermittently stops responding -gestures do not work -battery life too short -physically damaged	<b>K15</b> <b>K09</b> <b>K13</b> <b>K12</b> <b>K08</b>  <b>K02</b> <b>K16</b> <b>K16</b>
2. Try to pair Bluetooth device using the Bluetooth Setup Assistant, and verify that device can be recognized and used.	Yes	Issue does not happen with known-good batteries. If device was using standard batteries, go to step 5 to retest with user's batteries. If device had fully charged Apple rechargeable batteries, go to <a href="#">Apple Battery Charger Does Not Charge Batteries.</a>	
	No	Go to step 3.	
3. (Apple Wireless Keyboard , Magic Mouse, Magic Trackpad) Run Bluetooth Diagnostic Utility again and check the "Restore Factory settings" option at final window, and verify that test passes.	Yes	Go to step 4.	
	No	Replace defective Bluetooth device specifying the code provided by BSD or corresponding symptom code: -intermittently stops responding -gestures do not work -battery life too short	<b>K08</b>  <b>K02</b> <b>K16</b>
4. Try to pair Bluetooth device using the Bluetooth Setup Assistant. Verify that device can be recognized and used.	Yes	Issue resolved.	
	No	Go to <a href="#">Wireless Input Device Loses Connection.</a>	



5. Reinstall user's batteries in device and try to pair Bluetooth device using the Bluetooth Setup Assistant. Verify that device can be recognized and used.	Yes	Issue resolved.	
	No	Recommend that user replace batteries. If device had fully charged Apple rechargeable batteries, go to <a href="#">Apple Battery Charger Does Not Charge Batteries.</a>	

## Apple Wireless Mouse/Magic Trackpad Erratic Tracking

### Quick Check

Symptoms	Quick Check
<p><b>Apple Wireless Mouse/Magic Trackpad Erratic Tracking.</b></p> <ul style="list-style-type: none"> <li>• Cursor tracking is jumpy.</li> <li>• Tracking /Clicking/Tapping actions not working.</li> </ul>	<ol style="list-style-type: none"> <li>1. Check for and apply the latest software and firmware updates.</li> <li>2. Verify user is not using more than three Dual Link Bluetooth input devices at the same time on same computer.</li> <li>3. Cover the entire pad surface for a few seconds to reset it.</li> <li>4. Clean mouse sensor/ pad surface.</li> <li>5. Review Apple Support article <a href="#">TS3048: Troubleshooting wireless mouse and keyboard issues.</a></li> <li>6. Use a known-good up-to-date Mac OS X computer with Bluetooth enabled, where a known-good similar Bluetooth device could be previously paired, and where a wired mouse is connected.</li> <li>7. (Apple Wireless Keyboard , Magic Mouse or Magic Trackpad) Run Bluetooth Service Diagnostic (BSD), checking the Restore Defaults Settings option.</li> <li>8. (Apple Wireless Keyboard , Magic Mouse or Magic Trackpad) If BSD tests pass, try to pair again the device using the Bluetooth Setup Assistant.</li> <li>9. Replace defective Bluetooth device specifying the code provided by BSD.</li> </ol>



## Wireless Input Device Loses Connection

### Quick Check

Symptoms	Quick Check
<p><b>Wireless Input Device Loses Connection</b></p> <ul style="list-style-type: none"> <li>Apple Wireless keyboard, Magic Mouse, Magic Trackpad or other Bluetooth input device loses connection.</li> </ul>	<ol style="list-style-type: none"> <li>Restart computer.</li> <li>Check orientation of wireless device to computer. Test Magic Trackpad or Magic Mouse with it positioned on either side of computer.</li> <li>Verify that user is first clicking/pressing a key to wake input device. See Apple Support article <a href="#">HT3081: Click the mouse button to re-establish a connection to your Apple wireless mouse or trackpad.</a></li> <li>Verify whether device has been paired to computer previously.</li> <li>Remove and reinstall batteries for device.</li> <li>Press power button and check that green LED stays lit for around 3 seconds.</li> <li>Test with known-good batteries.</li> <li>Ensure that user is not using more than three Dual Link Bluetooth devices, at same time on same computer.</li> <li>Ensure other devices pair and keep connection without issue on the computer. If not, jump to <a href="#">Bluetooth Issues</a> symptom flow.</li> <li>Ensure that device is being used within 30-foot range for Bluetooth devices.</li> <li>Check for and apply the latest software and firmware updates.</li> <li>See Apple Support article <a href="#">TS3048: Troubleshooting wireless mouse and keyboard issues.</a></li> </ol>

### Deep Dive

Check	Result	Action	Code
1. Open System Preferences > Bluetooth. Paired items and their connection status are shown. Verify if device is listed.	Yes	Device has been paired. Go to step 2.	
	No	Device is not paired. Make device discoverable and open Bluetooth Setup Assistant. Go to step 3.	



2. Make sure device is on. In System Preferences > Bluetooth, select device and from the Action menu (gear) choose "Connect". Verify if device connects successfully.	Yes	Go to step 7.	
	No	Delete pairing in System Preferences. Go to step 3.	
3. With the device on, run Bluetooth Setup Assistant. Verify if you can successfully pair the device.	Yes	Go to step 7.	
	No	Restart computer. Go to step 4.	
4. With device on, run Bluetooth Setup Assistant. Verify if you can successfully pair device.	Yes	Go to step 7.	
	No	Create a new Admin User. Go to step 5.	
5. Log into new Admin User account. With device on, run Bluetooth Setup Assistant. Verify if you can successfully pair device with new user account.	Yes	User account issue. Troubleshoot software on User account. No hardware repair needed.	
	No	Remove the following file: /Library/Preferences/com.apple.Bluetooth.plist Go to step 6.	
6. Restart computer, With device on, run Bluetooth Setup Assistant. Verify if you can successfully pair device.	Yes	Go to step 7.	
	No	Go to <a href="#">Bluetooth Issues</a> symptom flow.	
7. With device paired and connected, verify if device connection is stable if used normally.	Yes	Issue resolved.	
	No	Check wireless device manual to verify if device is being used in accordance with manufacturer's specifications (range, OS support, battery types). Go to step 8.	
8. Verify if Apple wireless input device is performing to stated specifications.	Yes	Educate user. Issue resolved.	
	No	Replace defective Apple wireless input device according to symptom: -intermittent stops responding -gestures do not work -battery life too short	<b>K08</b> <b>K02</b> <b>K16</b>



## Apple Battery Charger Does Not Charge Batteries

### Quick Check

Symptoms	Quick Check
<p><b>Apple Battery Charger Does Not Charge Batteries</b></p> <ul style="list-style-type: none"> <li>No Amber/Green status LED visible on charger when batteries are installed and charger is connected to AC.</li> <li>Amber status LED is flashing</li> <li>When installed in the input device, the batteries don't power it.</li> <li>Batteries only provide limited run time when used.</li> <li>Batteries show leak/inflation signs</li> </ul>	<ol style="list-style-type: none"> <li>Ensure that only NiMH AA rechargeable batteries are used with the Apple Battery Charger, that they are correctly installed, with correct polarity orientation. If Amber status LED still flashes when these batteries are installed, they are likely to be defective.</li> <li>Ensure that NiMH AA rechargeable batteries were left charging for at least 5 hours (LED will go Green when a full charge has been reached, then will turn off to conserve energy).</li> <li>Test with known-good AC duckhead plug.</li> <li>Quickly test user's Apple Battery Charger for charge of a known-good set of NiMH AA rechargeable batteries . If no Amber or Green status LED is seen with this set, replace battery charger (P01).</li> <li>Quick check user's NiMH AA rechargeable batteries for charge status when installed in a known-good Apple Battery Charger. If no Amber/ Green status LED is seen, replace Apple battery set (P01).</li> </ol>

### Deep Dive

Check	Result	Action	Code
1. Verify status LED goes ON (Green or Amber) when a known-good set of NiMH AA rechargeable batteries is installed and charger is connected to AC outlet.	Yes	Go to step 2.	
	No	Check batteries fit and are correctly seated in case. If issue persist, replace defective Apple Battery Charger.	<b>P01</b>
2. Verify status LED goes Amber when a set of known-good discharged or only partly-charged NiMH AA batteries is installed.	Yes	Go to step 3.	
	No	LED remains Green while known-good inserted batteries are still not fully charged (charger never initiates a charge): Replace defective Apple Battery Charger.	<b>P10</b>



<b>3.</b> Verify status LED will go Green when a known-good set of partly charged NIMH AA batteries was installed and had been left for some hours (up to 5 hours if a fully discharged set was installed in charger). <b>Note:</b> Status LED may turn OFF after charge has been completed more than an hour.	Yes	When charge of the known-good batteries set has ended (status LED turned to Green), insert them in a known-good input device and go to step 4.	
	No	LED remains Amber (never ends charging). Replace defective Apple Battery Charger.	<b>P10</b>
<b>4.</b> Check Battery Level in System Preferences > Trackpad or Mouse. Depending on device type, battery type, and time since last full charge, the battery level displayed should vary from 80% to almost full. Verify that battery level shows at least 80% charge.	Yes	Charge functionality confirmed. Return Apple Battery Charger to user and recommend to check rechargeable batteries set.	
	No	Charger does not correctly charge batteries Replace Apple Battery Charger.	<b>P10</b>

## Uncategorized Symptoms

### Quick Check

Symptoms	Quick Check
<b>Uncategorized Symptoms</b> <ul style="list-style-type: none"> <li>Unable to locate appropriate symptom code.</li> </ul>	<ol style="list-style-type: none"> <li>Reset SMC: shut down computer, unplug power cord, press and hold power button for 5 seconds, release power button, and reconnect power cord.</li> <li>Verify that external I/O device (where applicable) works on a known-good, same-model computer.</li> <li>For third party I/O devices, make sure necessary software is installed and up-to-date, and that device is supported with user's computer.</li> </ol>

### Deep Dive

Check	Result	Action	Code
<b>1.</b> Verify if existing symptom code applies to issue reported by user.	Yes	Jump to appropriate symptom code flow.	
	No	Document reported failure and send feedback to <a href="mailto:smfeedback6@apple.com">smfeedback6@apple.com</a> stating that a suitable symptom code wasn't found. Provide as much detail as possible.	<b>N99</b>



# Mechanical

## Noise/Hum/Vibration

Unlikely cause: LCD panel, glass panel, rear housing, cables

### Quick Check

Symptoms	Quick Check
<p><b>Noise/Hum/Vibration</b></p> <ul style="list-style-type: none"> <li>• Buzzing noise</li> <li>• Rattling noise</li> <li>• Ticking noise</li> <li>• Squeaking noise</li> </ul>	<ol style="list-style-type: none"> <li>1. Verify that the vents on the bottom and back of the computer are free of dust and other obstructions that might inhibit proper airflow through the computer.</li> <li>2. Launch Applications &gt; Utilities &gt; Activity Monitor. Determine whether an application or process is consuming a high percentage of CPU bandwidth. CPU-intensive applications can cause the fans to run fast in order to maintain the proper internal computer temperatures. If needed, quit the application or restart the computer to resolve the issue.</li> <li>3. Eject optical media from optical drive. Out-of-balance optical media can generate audible noise. To resolve try a different brand of media. For additional information, go to <a href="#">Optical Drive Noisy</a> symptom flow.</li> <li>4. Tilt display to hinge limits to determine if mechanical noise is generated by the hinge mechanism. For additional information, go to <a href="#">Stand/Hinge Issues</a> symptom flow.</li> <li>5. Play sound sample at loud and soft volume levels to determine if the noise is caused by the left/right speakers or the amplifier circuit. Plug external headphones to identify whether the noise comes from audio out or from other source. For additional information, go to <a href="#">Distorted Audio From Internal Speaker(s)</a> symptom flow.</li> <li>6. Adjust the display brightness to determine whether the noise is related to the brightness level. For additional information, go to <a href="#">Noise/Unstable Flickering</a> symptom flow.</li> <li>7. Run latest available Apple service utilities.</li> </ol>



## Deep Dive

Check	Result	Action	Code
1. Verify if any tape, gasket, cable label, or cable is touching the fan blades and causing a ticking noise.	Yes	Secure the material so it doesn't touch fan blades. If tape adhesive has lost its stickiness, replace that section of tape.	
	No	Go to step 2.	
2. Run latest available Apple service utilities and verify if it reports one or more errors.	Yes	Locate affected part and check for correct cable seating. Use <a href="#">diagnostics error codes table</a> and <a href="#">sensors location table</a> (in General Troubleshooting section) to decode error. Follow instructions in table for resolving error, then retest.	
	No	Go to step 3.	
3. Verify if noise sounds like one or more fans are spinning faster than expected.	Yes	Reset SMC and retest. If issue continues, go to step 3.	
	No	Go to step 6.	
4. Verify if noise changes when optical drive is being accessed or media is inserted or ejected.	Yes	Suspect issue with optical drive or media used. Go to <a href="#">Optical Drive Noisy</a> symptom flow.	
	No	Go to step 5.	
5. Mute the computer volume. Verify if issue still occurs.	Yes	Go to step 6.	
	No	Suspect issue with speakers or audio amplifier circuitry. Go to <a href="#">Distorted Audio From Internal Speaker(s)</a> symptom flow.	
6. Adjust brightness on display between maximum and minimum settings. Verify if issue changes depending on brightness level.	Yes	Suspect issue with LCD display or backlight controller board. Go to <a href="#">Noise/Unstable Flickering</a> symptom flow.	
	No	Go to step 7.	
7. Remove fans and rotate blades. Verify if fan blades spin smoothly without interference from fan housing.	Yes	Go to step 8	
	No	Replace affected fan.	<b>P04</b>



<b>8.</b> Reinstall fans while carefully ensuring that there are no cables routed under or near fan assembly that might cause interference with fan blades. After reassembling computer verify if noise issue is resolved.	Yes	Noise issue resolved. Suspect issue caused by interference from wiring or possible distortion or fan housing when installed in computer.	<b>P04</b>
	No	Go to step 9.	
<b>9.</b> Temporarily remove LCD panel then power ON computer. Verify if source of noise can be located. <b>Caution:</b> The exposed power supply poses a serious shock hazard. Take proper precautions when working around an energized computer.	Yes	Identify, inspect, and if necessary replace part that caused noise issue.	<b>P04</b>
	No	Go to step 10.	
<b>10.</b> Disconnect these major modules/parts (hard drive, optical drive, fans, LCD panel) one at a time then power ON the computer. Determine if noise issue goes away when one of the modules is disconnected. <b>Caution:</b> The exposed power supply poses a serious shock hazard. Take proper precautions when working around an energized computer.	Yes	Identify, inspect, and if necessary replace part that caused noise to disappear when it was disconnected from the computer.	<b>P04</b>
	No	All parts verified. Verify that correct symptom flow is being used.	



## Fan Failures / Thermal Issues

Unlikely cause: speakers

### Quick Check

Symptoms	Quick Check
<b>Fan Failures / Thermal Issues</b> <ul style="list-style-type: none"><li>• Computer feels very hot</li><li>• Fan(s) not operating</li><li>• Fan(s) running fast</li><li>• Computer is noisy</li></ul>	<ol style="list-style-type: none"><li>1. Verify that vents on bottom and back of computer are free of dust and other obstructions that might inhibit proper airflow.</li><li>2. Verify that computer is not exposed to direct sunlight which may heat up enclosure, making it feel hot to the touch.</li><li>3. Verify computer is not running hotter than expected for normal operation. If possible, compare to a similarly configured computer. <b>Note:</b> Power supply is located in upper left corner where highest temperatures can usually be felt.</li><li>4. Launch Applications &gt; Utilities &gt; Activity Monitor. Verify if an application or process is consuming a high percentage of CPU bandwidth. CPU-intensive applications can cause fans to run fast in order to maintain proper internal computer temperatures. If needed, quit the application or restart computer to resolve issue.</li><li>5. Reset SMC: shut down computer, unplug power cord, press and hold power button for 5 seconds, release power button, and reconnect power cord.</li><li>6. Run Mac Resource Inspector (MRI) and examine results. Redirect to appropriate symptom.</li><li>7. Verify that the computer's internal hard drive is an Apple-installed part. Third-party hard drives may not be within specifications or have correct firmware for this product and may cause the computer to run hot. In such cases, inform user that the computer has been modified from its original and supported configuration, and that this repair would not be covered under Apple warranty.</li></ol>



## Deep Dive

Check	Result	Action	Code
1. Run latest available Apple service utilities and verify if one or more errors are reported.	Yes	Suspect possible fan or sensor error. Use <a href="#">diagnostics error codes table</a> and sensors location table (in General Troubleshooting section) to decode error. Follow instructions in table for resolving error, then retest.	
	No	Go to step 2.	
2. Verify if noise sounds like one or more fans running faster than expected.	Yes	Fans running fast. Reset SMC and retest. If issue continues, go to step 3.	
	No	Go to step 3.	
3. Verify if any tape, gasket, cable label, or cable is touching the fan blades and causing a ticking noise	Yes	Secure the material so it doesn't touch fan blades. If tape adhesive has lost its stickiness, replace that section of tape	
	No	Go to step 4.	
4. Remove fans and rotate blades. Check for any dust that could be clogging the fans. Verify if fan blades spin smoothly without interference from fan housing and fan blades are all intact.	Yes	Go to step 5.	
	No	Replace affected fan(s).	<b>X23</b>
5. Run latest available Apple service utilities then ASD in stand-alone tests looping mode, to verify if all sensor or fans related tests pass.	Yes	Noise issue resolved.	
	No	Check for correct sensors/fans connections on logic board. Check for pinched cables. Compare with known-good similar computer, and check for unlisted sensors. Replace affected sensor/fan.	<b>X22</b>



## Stand/Hinge Issues

Symptoms	Quick Check
<b>Stand/Hinge Issues</b> <ul style="list-style-type: none"> <li>• Bent stand</li> <li>• Broken hinge</li> <li>• Stripped screw/head</li> <li>• Stripped screw boss</li> </ul>	<ol style="list-style-type: none"> <li>1. Determine whether damage caused by user / technician environment, accidental damage, or abuse. If so, inform user/technician the failures are not covered by Apple warranties. Refer to <a href="http://www.apple.com/legal/warranty">http://www.apple.com/legal/warranty</a></li> <li>2. For hinge noise issues replace hinge mechanism.</li> </ol>

## Physical Damage

Symptoms	Quick Check
<b>Physical Damage</b> <ul style="list-style-type: none"> <li>• Broken glass</li> <li>• Bent stand</li> <li>• Broken hinge</li> <li>• Stripped screw/head</li> <li>• Stripped screw boss</li> <li>• Dent or scratch to chassis</li> </ul>	<ol style="list-style-type: none"> <li>1. Verify if damage caused by user environment, accidental damage, or abuse. If applicable inform the user that Apple does not warrant damage caused by accident, abuse, misuse, flood, fire, earthquake, or other external causes. Refer to: <a href="http://www.apple.com/legal/warranty">http://www.apple.com/legal/warranty</a></li> <li>2. Refer to Apple Support article <a href="#">CP161: SERVICE: Determining and Quoting Accidental Damage</a>.</li> </ol>

## Uncategorized Symptoms

Check	Result	Action	Code
1. Verify if existing symptom code applies to issue reported by user.	Yes	Jump to appropriate symptom code flow.	
	No	Document reported failure and send feedback to <a href="mailto:smfeedback6@apple.com">smfeedback6@apple.com</a> stating that a suitable symptom code wasn't found. Provide as much detail as possible.	<b>N99</b>

**Take Apart**

---

**iMac (21.5-inch, Mid 2011)**



# General Information

## Opening the Computer

- The iMac (21.5-inch, Mid 2011) has a glass panel that attaches to the front, which must be removed prior to replacing any module other than Memory.
- **Important:** The glass panel should only be removed by Apple-authorized technicians. Follow all cleaning and handling instructions to prevent damaging glass panel or LCD panel.
- Follow ESD precautions when glass panel is removed.

For more information about ESD, refer to Apple Support article

[HT3451: Electrostatic Discharge Precautions and Myths](#)

[AppleCare Service Training: ESD Precautions](#)

## Required Tools

The following tools are required to service an iMac (21.5-inch, Mid 2011):

- ESD-safe workstation, including an ESD mat and wrist or heel strap
- ESD bags (for storing ESD-sensitive parts while removed from computer)
- Magnetized Torx T10 screwdriver
- Magnetized Torx T8 screwdriver
- Magnetized Torx T6 screwdriver
- Phillips #1 screwdriver
- Black stick (nylon probe, Apple part #922-5065) or other non-conductive nylon or plastic flat-blade tool
- Thunderbolt and USB cables for logic board reassembly
- Earbuds for audio cable reassembly
- Thermal material syringe (Apple part #922-9625) for camera
- Kapton tape
- Magnifying glass, for reading serial number etched on bottom of stand
- Digital volt meter (for troubleshooting)
- Soft, clean towel or cloth (to protect display and removed parts from scratches)

For more information about tools, refer to Apple Support article

[HT3452: Hand Tools for Desktop and Portable Repairs](#)



## Required Special Tools for Glass Panel

Special tools are required to remove, handle and clean glass panel.

- 922-8252 – Suction cups, Pkg of 2
- 922-8253 – Gloves, lint-free, anti-static, Pkg of 2
- 922-8258 – ESD bags, 24"x20"; Pkg of 5. To prevent buildup of static charges which may attract dust particles, store LCD panel in an ESD bag when it is removed from computer.
- 922-8259 – Microfoam bag to store glass panel, Pkg of 5
- 922-8261 – Sticky silicone roller (6-inch) to clean glass panel
- 922-8262 – Sticky sheet pads to clean silicone roller
- 922-8263 – Polishing cloths, anti-static, optical-grade micro-terry, Pkg of 5

## Cleaning Tools Starter Kit

The following tools are offered in the cleaning starter kit (076-1277):

- Suction cups, 1 pair
- Gloves, lint-free, anti-static, 2 pairs
- Sticky silicone roller (6-inch) to clean glass panel
- Sticky sheets to clean the silicone roller, 2 pads
- Polishing cloths, clean, anti-static, optical-grade micro-fiber "terry" style, 5 cloths
- Microfoam bag to store glass panel, 5 bags
- ESD bag for LCD panel storage, 5 bags



## Cleaning & Handling the Glass Panel

Follow cleaning procedures in this manual to ensure glass panel is free of dust and other particles before returning the computer to user.

- The glass panel is not tempered and will break into sharp pieces if mishandled. A scratched or broken glass panel is not covered under warranty.
- Removing glass panel requires special tools such as lint-free gloves, rubber suction cups, and microfoam storage bags.
- To prevent contamination, wear lint-free gloves and handle glass only by edges.

### Do's and Don'ts

#### DO

- Handle glass panel using lint-free gloves.
- Use only a sticky silicone roller to clean the inside surface of glass and LCD panel.
- Place glass panel into a clean protective microfoam bag when removed from computer.
- Store glass panel in a safe area where it will not be broken or damaged.
- Store LCD panel in an anti-static bag to prevent buildup of static charges which may attract dust particles to display's surface.
- Store silicone roller and sticky paper within a temperature range of 39-104 F (5-40 C).
- If silicone roller is no longer tacky, wash it in warm soapy water or wipe with isopropyl alcohol. If tackiness does not return, replace silicone roller.

#### DON'T

- Touch inside of glass with bare hands or dirty gloves. Fingerprints are difficult to remove.
- Place glass panel onto a work surface where it may collect dust and other contaminants unless it has first been placed into a protective microfoam bag.

## Handling a Broken Glass Panel

The glass panel is not tempered and will break into sharp pieces if mishandled. If the glass is broken it must be carefully removed from the computer to prevent irreparable damage to the front surface of the LCD. If the front surface of the LCD is scratched by broken glass, the LCD may need to be replaced.



## How to Remove a Broken Glass Panel

A shattered panel can be removed using safety glasses, packing tape, and leather gloves.

1. Put on the safety glasses and leather gloves.
2. Lay the computer on a smooth, clean work surface.



3. Peel protective covering off the front of the glass. Remove and discard any large pieces of broken glass.





4. Apply a strip of packing tape horizontally across the top and bottom of the glass panel. Next, apply the tape diagonally, across the broken glass panel, forming an "X."

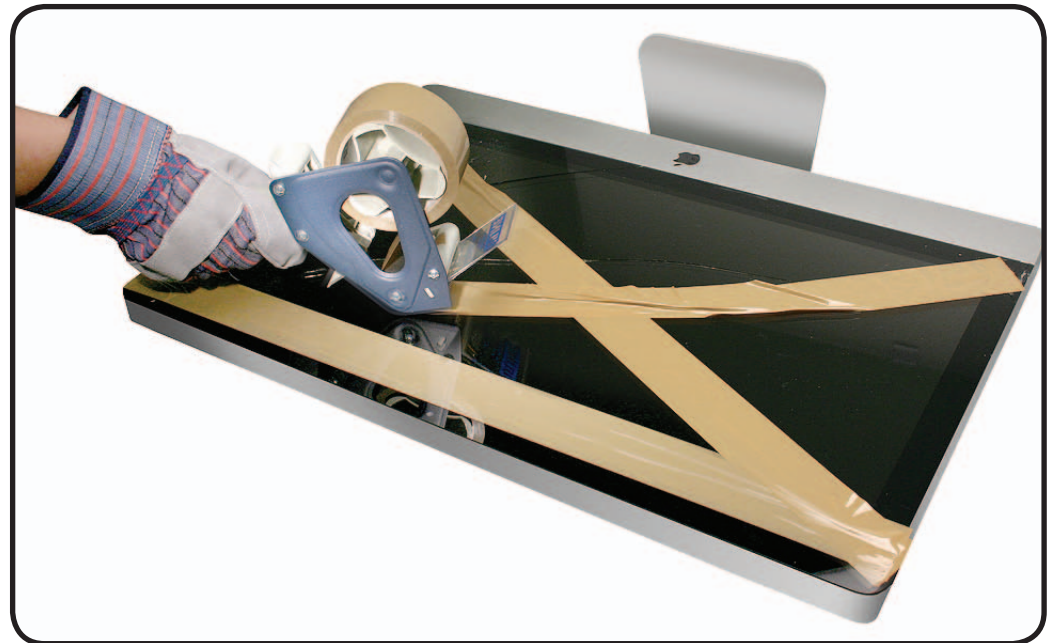

5. Continue applying tape horizontally, thoroughly covering the broken glass. Most of the glass will still be attached to the steel ring that runs around the perimeter of the glass panel.





6. Use a black stick to pry the glass panel off the magnets on the rear housing.



7. Lift the entire glass panel off the rear housing.

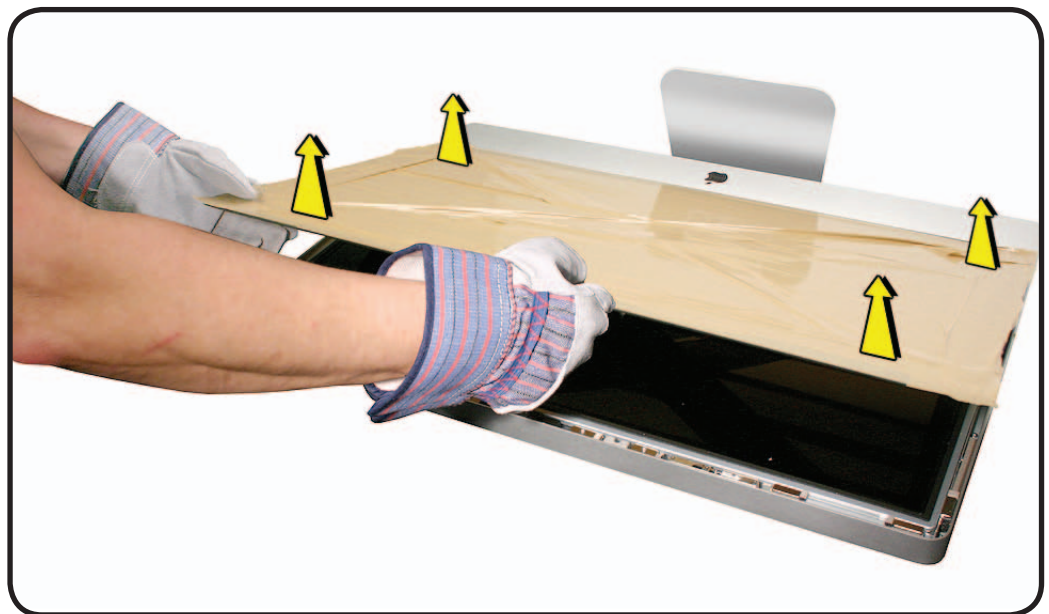



8. Place the broken glass inside a large box, label the box, and dispose of it properly.



9. Using a whisk broom, clean the work surface of tiny glass particles.
10. Stand the iMac up and use a lint free cloth to carefully brush any of the particles off the iMac onto the table. Clean the work surface again.
11. When the repair is finished the cloth should be disposed of immediately.
12. Use a broom and dustpan to sweep up as much of the broken glass as possible. Glass fragments may have traveled several feet from the location of the glass panel, so be sure to thoroughly clean the entire area. Use a vacuum to remove the smaller fragments not picked up by the broom.

**Note:** A broken glass panel may leave one or more scratches on the LCD display depending on the severity of the glass breakage. As long as the LCD itself has not been fractured the LCD does not require replacement, but be sure to let the user know that the scratches are there and were caused by the broken glass panel.



## Safety



**Warning: HIGH VOLTAGE:** The AC/DC power supply PCB remains powered up whenever computer is plugged in, whether or not computer has been turned on. Use extreme caution when troubleshooting computer with glass panel removed.

- Don't work alone. In the event of electrical shock it is important to have another individual present who can provide assistance.
- Keep one hand in your pocket when working on any iMac computer that is plugged in. This will help ensure that your body does not provide a path to ground in the event that you accidentally make contact with line voltage.
- Don't wear jewelry, watches, necklaces, or other metallic articles that could present a risk if they accidentally make contact with power supply circuitry.

Use extreme caution when working around power supply. The power supply contains a high voltage capacitor that may remain charged for several minutes even when computer is unplugged. Never touch leads on top side of power supply, especially capacitor leads located near warning sign.

**Important:** If computer is shut down by removing power cord, allow power supply a good 2-3 minutes to discharge capacitors before handling it. However, if you select "Shut Down" via the Apple menu, the computer will discharge power supply capacitor almost immediately.

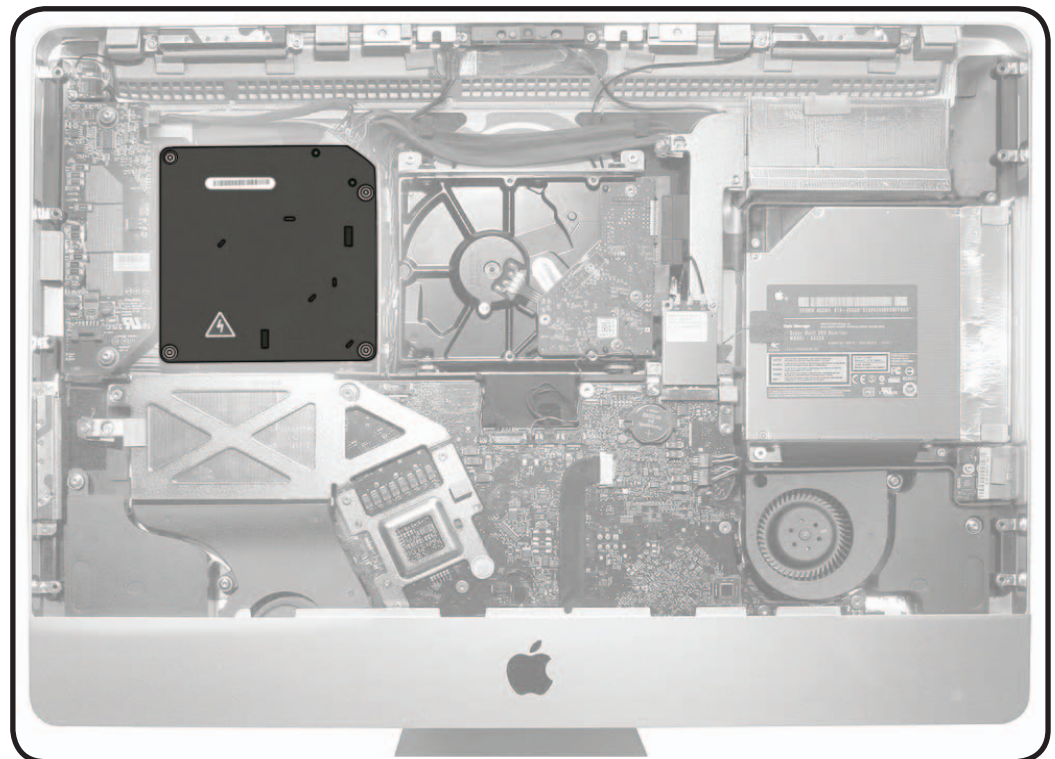



## Logic Board Handling

**IMPORTANT:** Always use two hands to support the logic board, video card and heat sinks. Handling incorrectly could flex the board and damage chips and circuitry. **Never** handle the board by heat sink or video card.

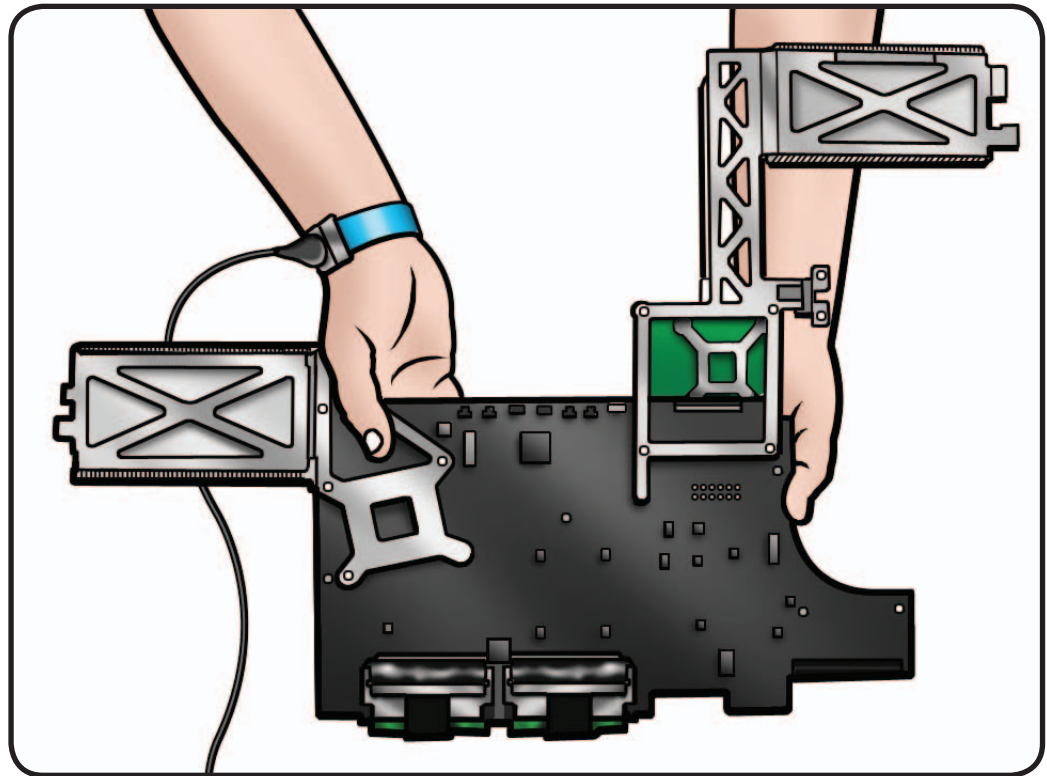

## Reassembly Steps

When no replacement steps are listed, replace parts in exact reverse order of Removal procedure.

## Note About Images in This Guide

Because a pre-production model was used for most images in this manual, you may notice minor differences in appearance between the image pictured and the computer you are servicing. However, although appearance may differ, steps and sequence are the same unless noted.

## Screw Sizes

All screw sizes shown are approximate and represent the total length of the screw.



# Access Door

## First Steps

- Shut down computer.
- Unplug all cables and the power cord.
- Put on ESD strap.
- Place computer face down on a clean, flat surface so the bottom is facing you.



## Tools

- ESD wrist strap
- Phillips #1 screwdriver

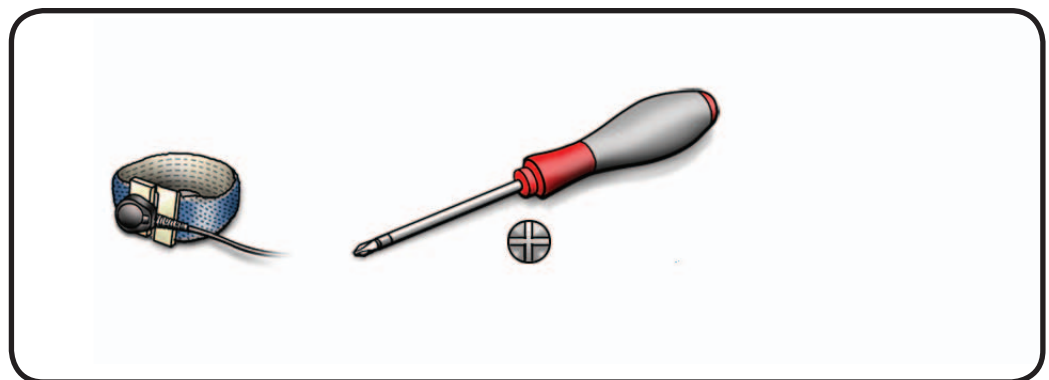



## Removal

- 1 Raise the stand and loosen 3 captive Phillips #1 screws.
- 2 Remove access door.

**Important:** To ensure proper cooling, iMac should not be operated without access door installed.





# Memory

## First Steps

Remove:

- Access Door

**Note:** This computer uses DDR3-1333 MHz, 204-pin SO-DIMMs. The maximum amount of memory is 16GB, with a 4GB DIMM installed in each slot.

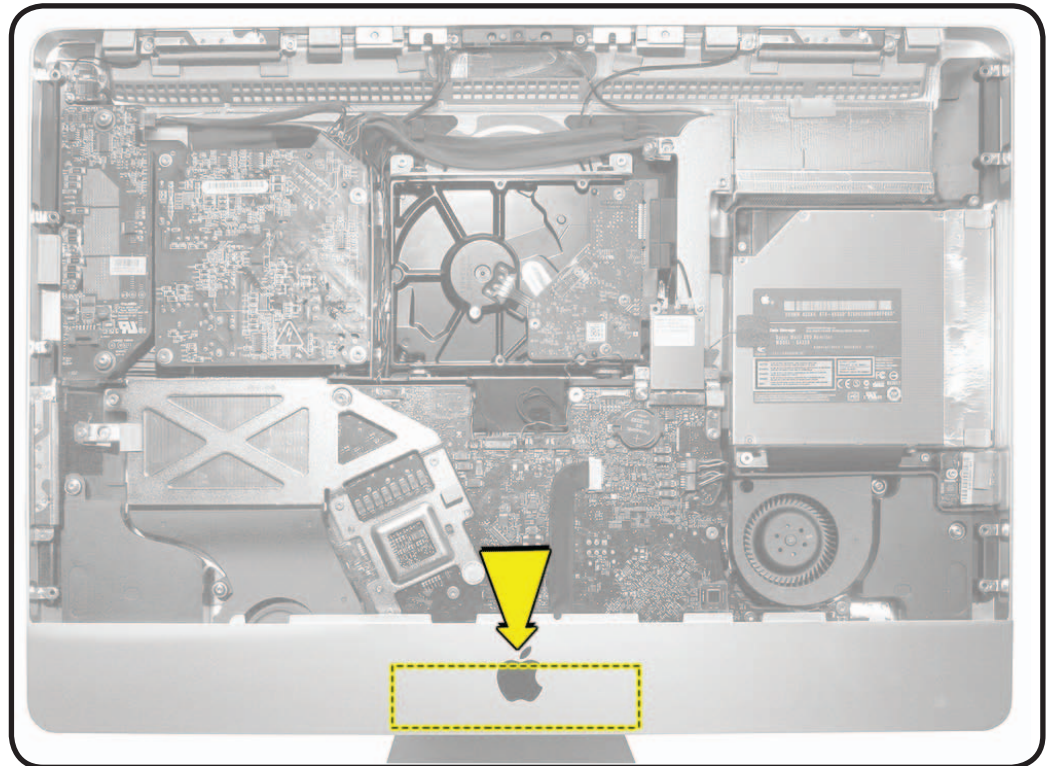

## Tools

- ESD wrist strap
- Black stick





## Removal

- 1 Untuck tabs in memory compartment.
- 2 Pull tab to eject installed memory module.  
**Tip:** For better grip, attach double-stick tape to end of tabs.

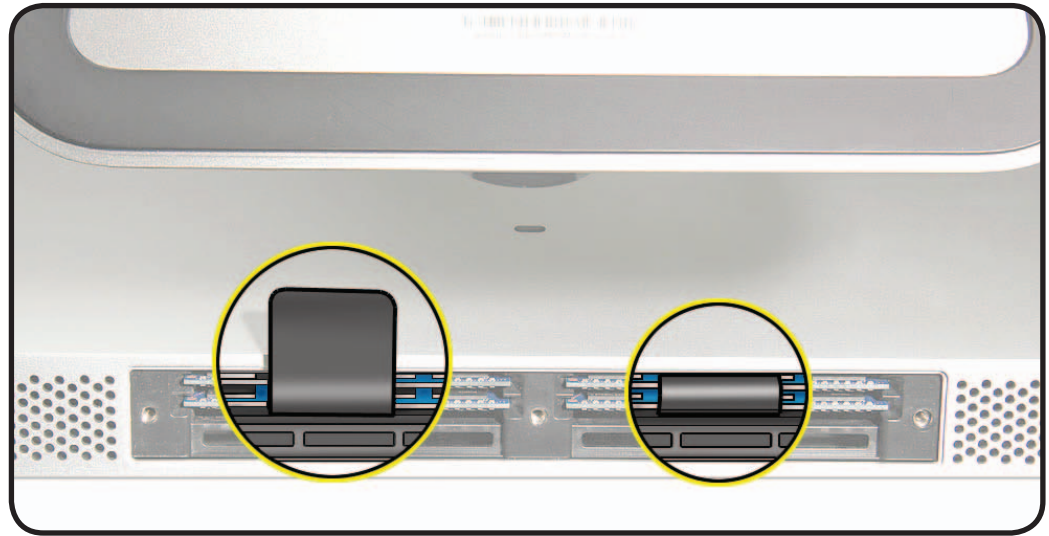

## Reassembly

- 1 Orient notch on memory with notch in memory compartment.
- 2 Press memory firmly into slot until you hear a click.
- 3 Tuck black plastic tabs into memory compartment.
- 4 Replace access door and tighten 3 captive screws.

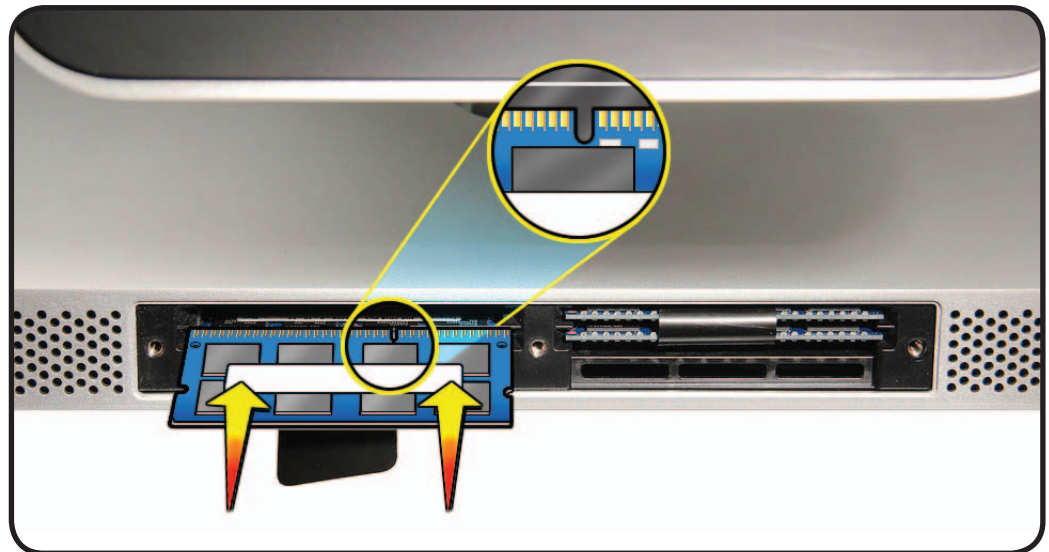

**Important:** To ensure proper cooling, iMac should not be operated without access door installed.



# Glass Panel

## First Steps

- Shut down computer.
- Unplug all cables and the power cord.
- Put on ESD strap.

**Caution:** The glass panel is not tempered and will break into sharp pieces if mishandled. A scratched or broken glass panel is not covered by warranty.

### Important:

This procedure requires special tools, which are offered individually or as part of a cleaning kit. See General Take Apart section for more information.



## Tools

- ESD wrist strap
- lint-free gloves
- suction cups
- sticky silicone roller
- sticky sheets to clean the silicone roller
- microfoam bag to store glass panel

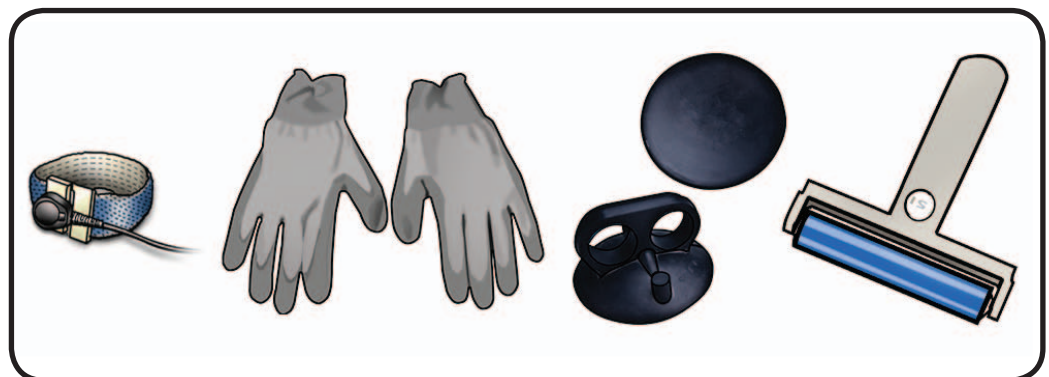



## Removal

**Note:** Glass panel is held in place by magnets.

**Caution:** The glass panel has tabs along bottom that align with rear housing. Be careful not to damage tabs when removing glass panel.

**Apple strongly recommends wearing clean, lint-free gloves whenever handling the glass panel, to reduce cleaning required on reassembly.**

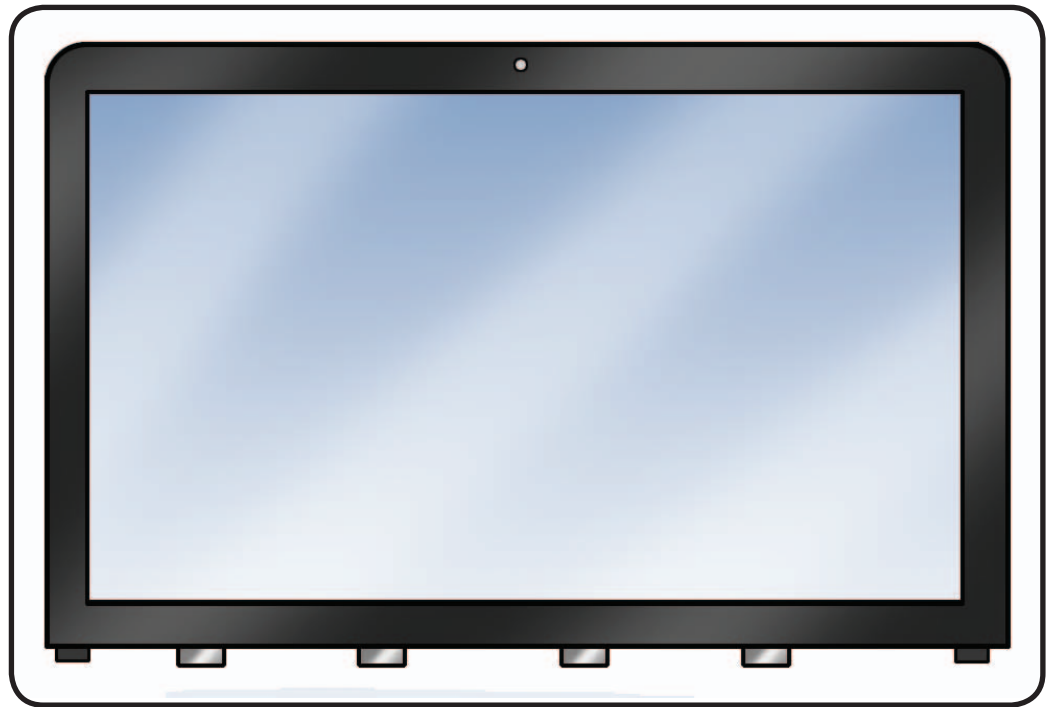

- 1 Glass panel can be removed in various ways:
  - Lay computer on its back and press clean suction cups in top right and left corners on clean glass panel (as shown), or...
  - Stand computer upright and use your finger nails to pull glass forward along top edge

- 2 Lift panel up and off.





- 3 Remove suction cups and slide glass into protective microfoam bag.

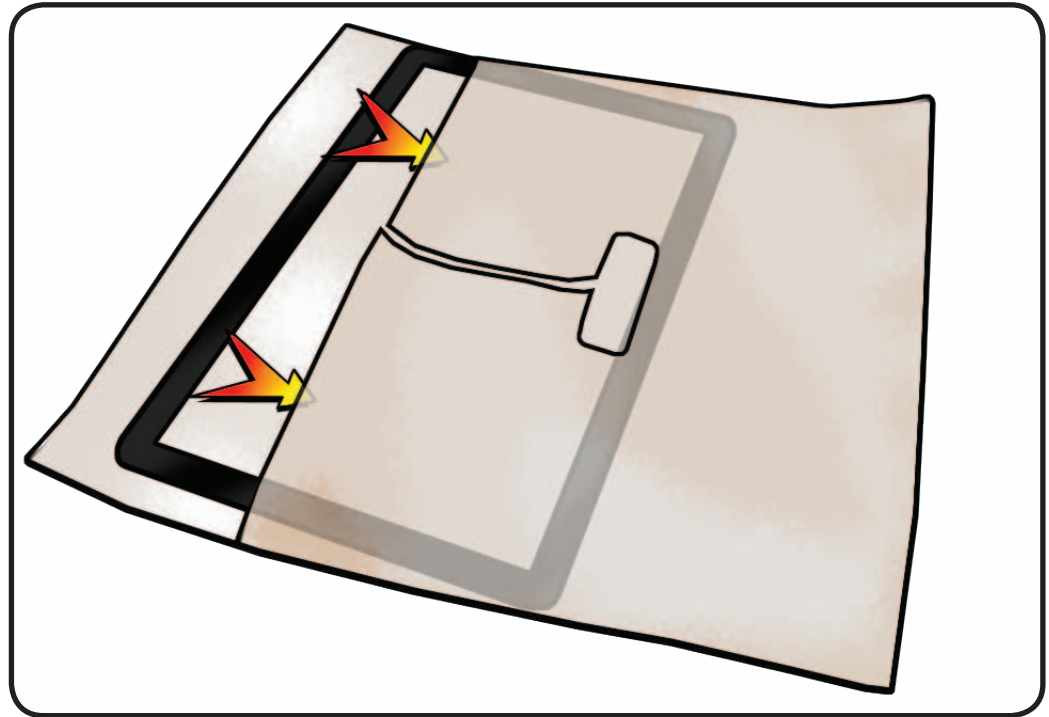

## Reassembly

- 1 Remove protective covering from silicone roller and sticky sheet.
- 2 Clean silicone roller by rolling it back and forth a few times on sticky sheet.

If sticky sheet looks dirty, use a new one.  
If roller is no longer tacky, wash it in warm soapy water.  
If tackiness does not return, replace silicone roller.

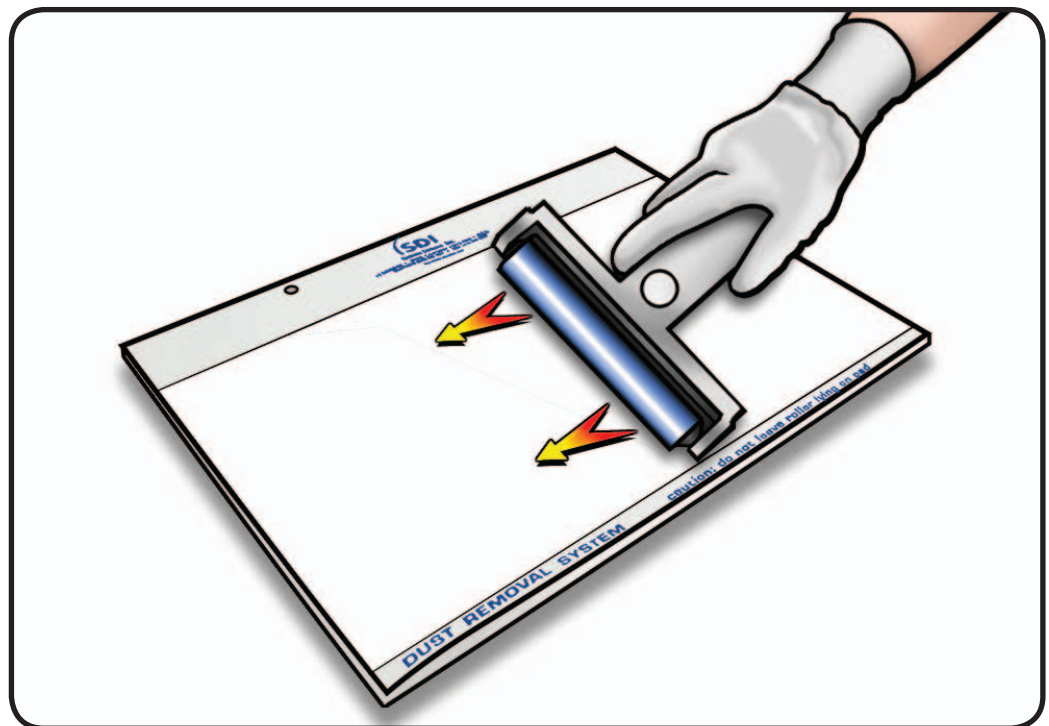



3 Set computer in upright position to minimize settling of dust.

4 Roll silicone roller over LCD panel to remove any particles.

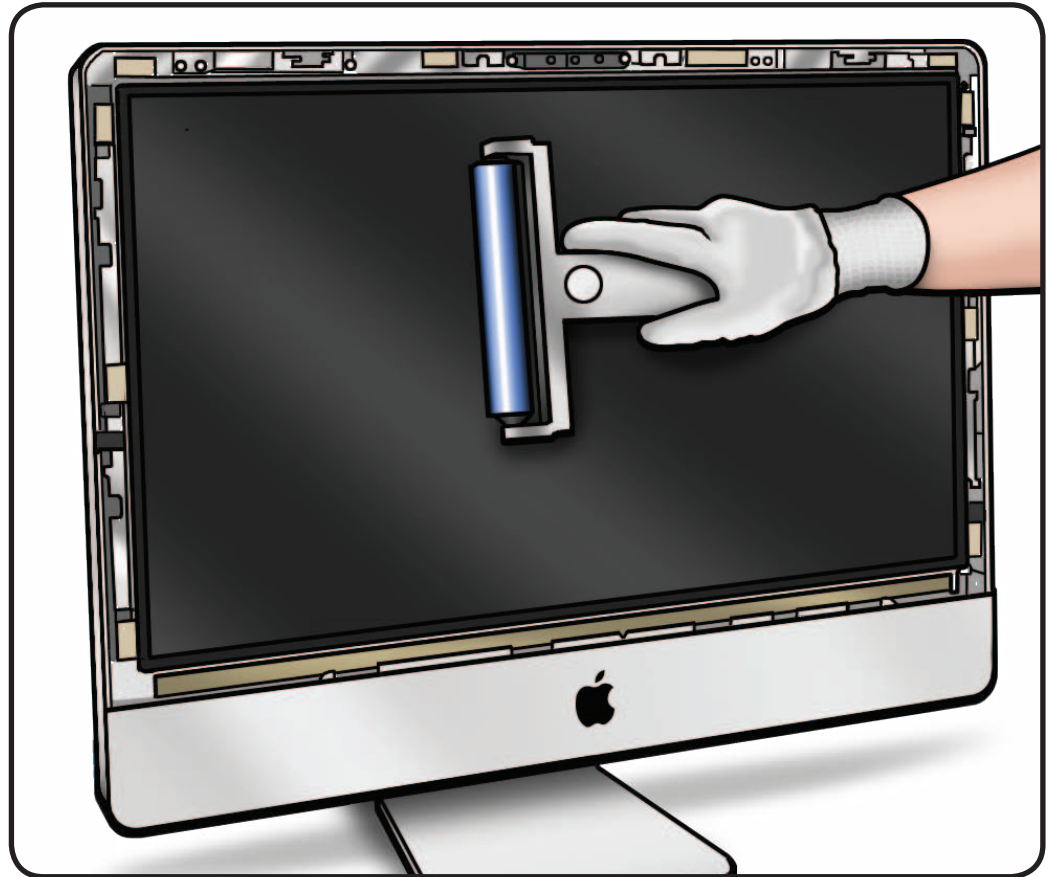

5 Remove glass panel from microfoam bag.

6 Clean INSIDE of glass panel with the silicone roller to remove dust.

**Note:** If fingerprints or oils are on inside of glass, clean first with a microfiber cloth made damp with water.





- 7** Wearing clean gloves, place glass directly onto computer, aligning tabs along bottom with notches in rear housing. Magnets will catch it and hold it in place.

Make sure glass is flush with rear housing after it is reinstalled.



- 8** Clean outside of glass panel with a clean microfiber cloth. Wipe glass until there is no longer any residue or haze.

- 9** Inspect glass for any remaining dust, fingerprints, or a hazy residue. If there are contaminants trapped between LCD panel and glass panel, repeat cleaning procedure.

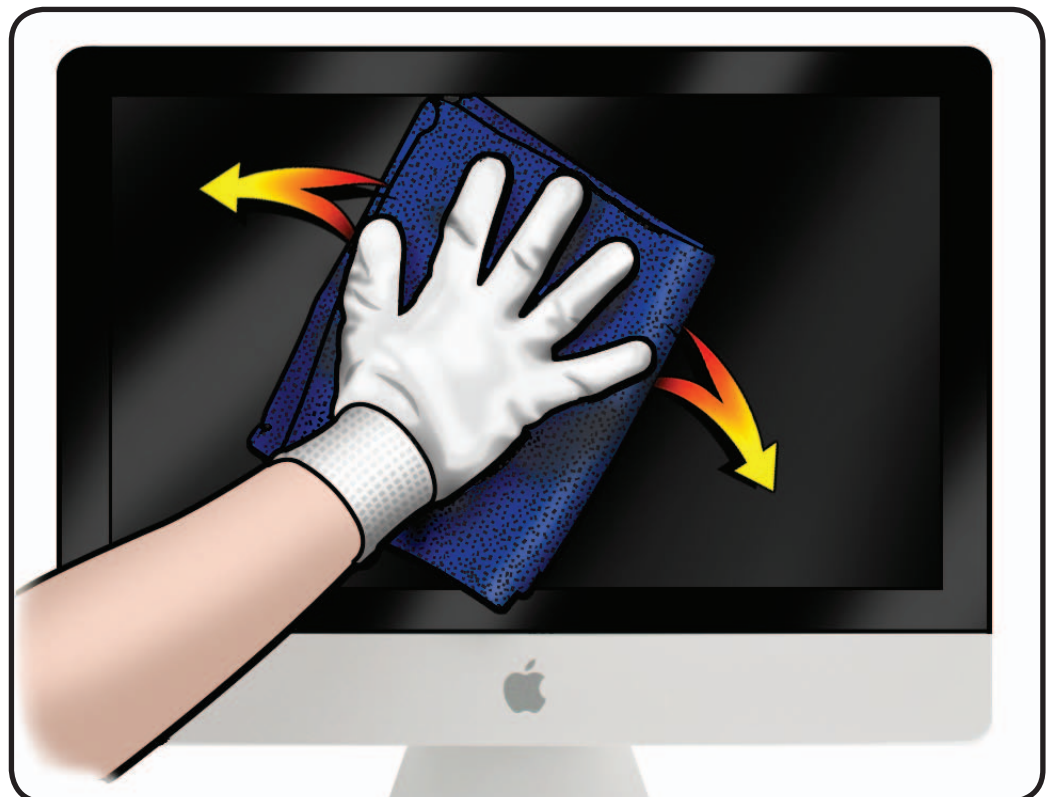



# LCD Panel

## First Steps

Remove:

- Glass Panel



**Caution:** Do not press on front surface of LCD panel when handling.

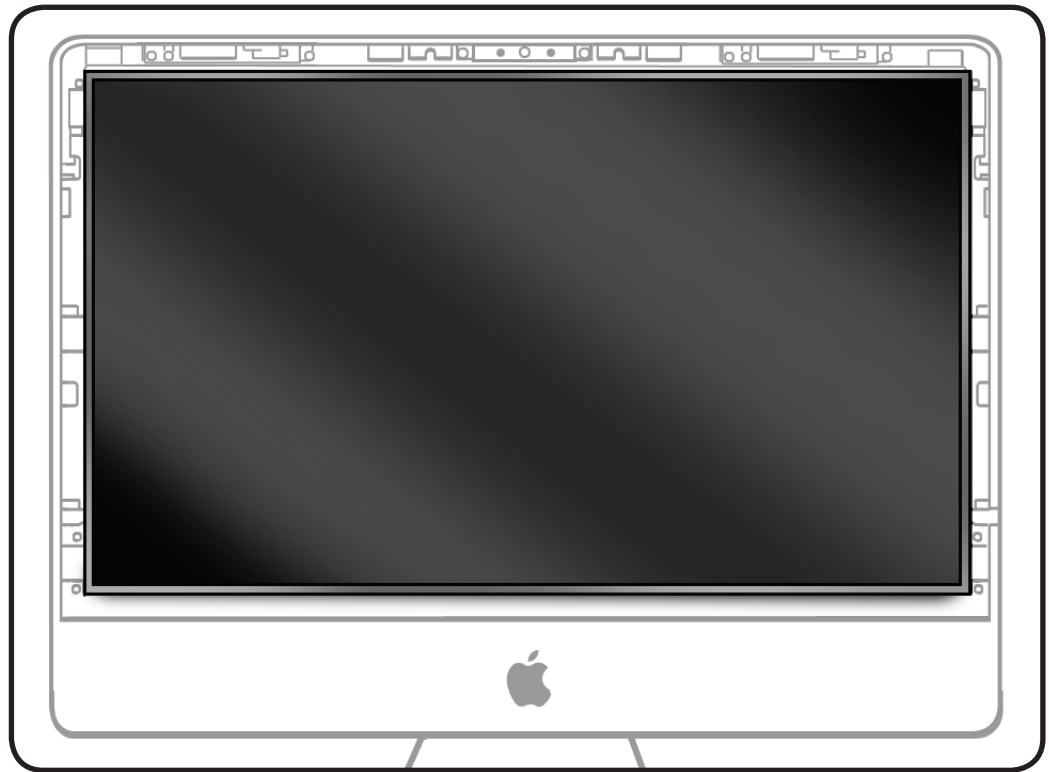

## Tools

- ESD wrist strap
- Torx T10 screwdriver
- ESD bag to store LCD panel

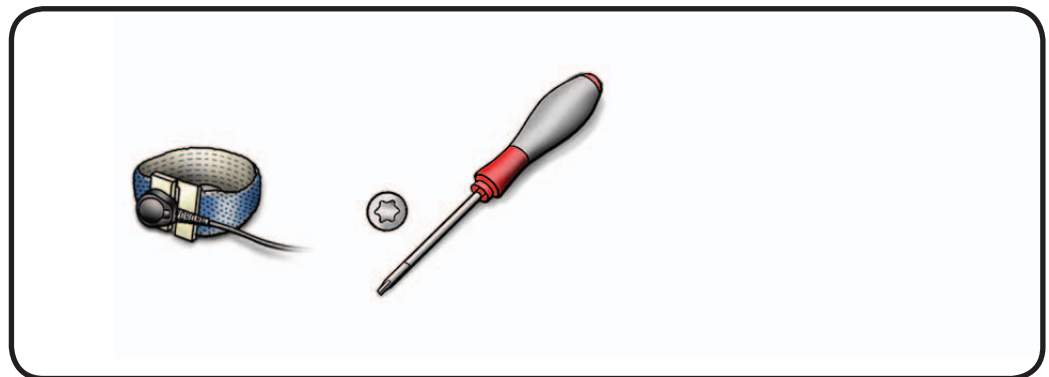



## Removal

- 1 Remove T10 screws:  
(8) 922-9246



### Reassembly Note:

Do not overtighten LCD screws, which could cause light leakage after computer is reassembled.



- 2 With computer standing up and facing you, pull the LCD forward slightly from the top edge to access cables inside.



**CAUTION:** Tilt display out no more than 4 inches (10 cm). Pulling display too far could damage cables or connectors.

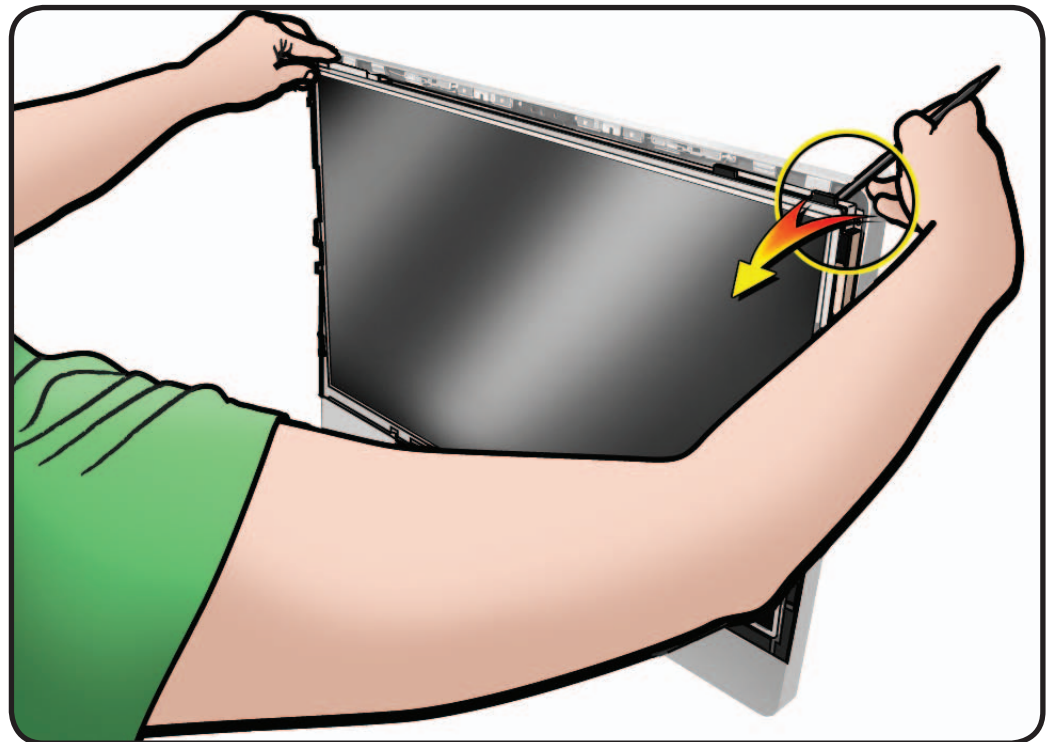



**3** Looking down into computer, disconnect 4 cables:

- #1: v-sync/temp
- #2: backlight power
- #3: DisplayPort power
- #4: DisplayPort

**Reassembly Note:**

Verify that all cables are firmly seated into connectors!

**Replacement Note:**

A new LCD panel includes all cables except the DisplayPort cable (#4).

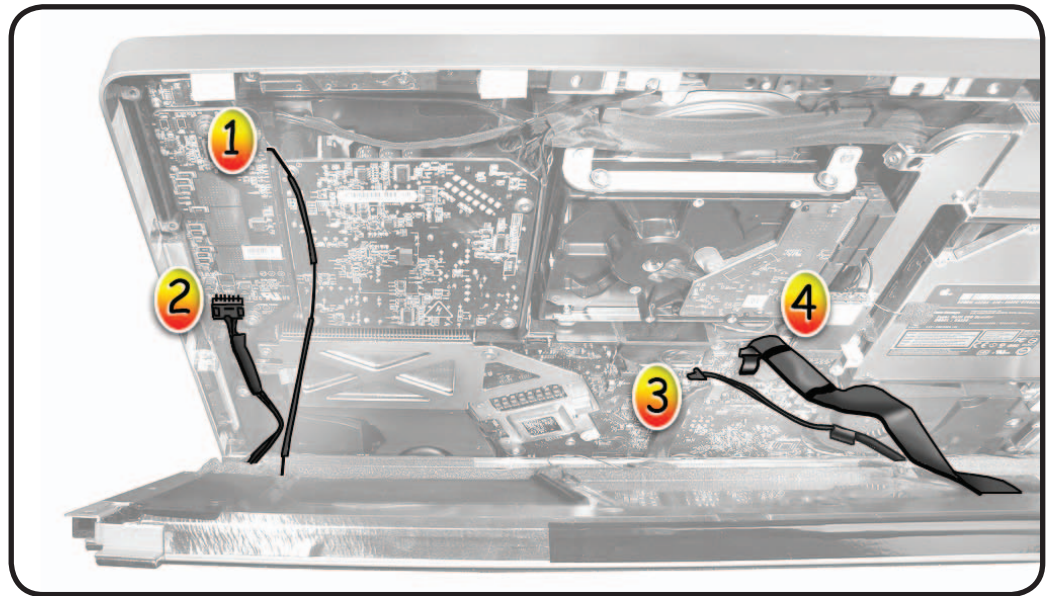

**LEFT:** Close-up of #1 v-sync/temp sensor cable at top of LED backlight board. Pull straight out of connector.

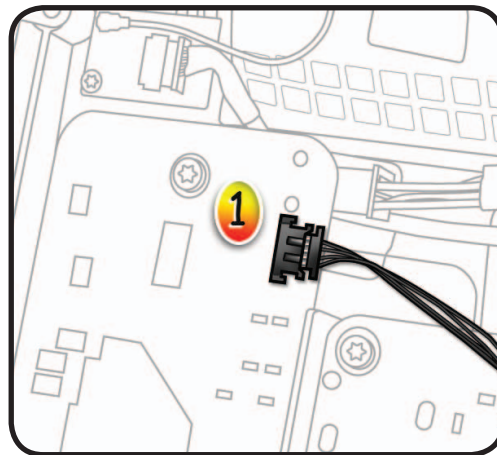

**RIGHT:** Close-up of #3 DisplayPort power cable at top center of logic board. Pull straight up.

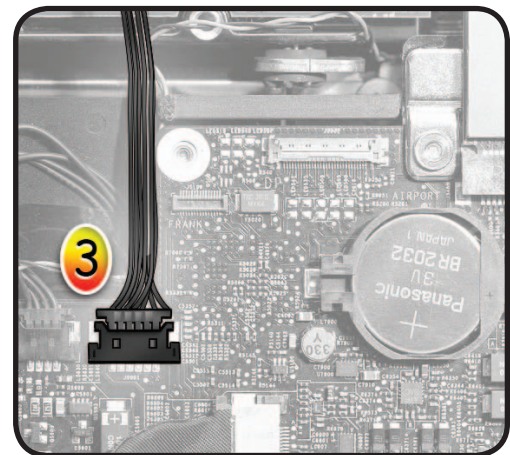

**LEFT:** Close-up of #2 backlight power cable at bottom of LED backlight board. Pinch and pull cable down from connector.

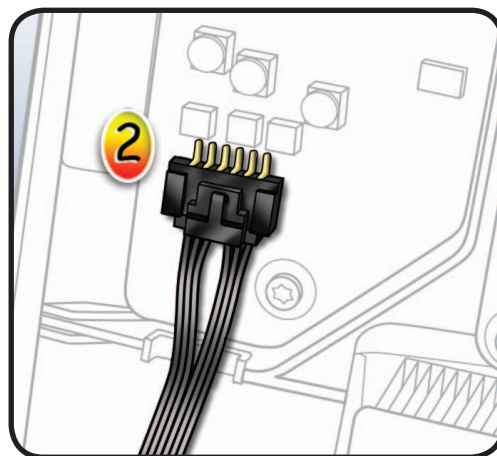

**RIGHT:** Close-up of #4 DisplayPort cable at top center of logic board. Flip up locking bar and then pull cable straight out of connector (see detail on next page).

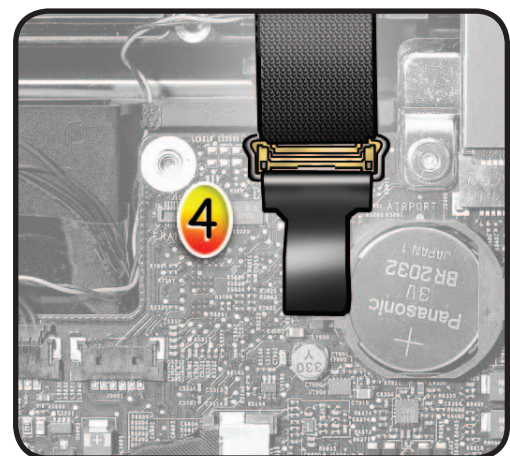



## Detail of DisplayPort Connector

This is a thin, multi-pin horizontal insert connector like those used in portable computers. Close-ups show DisplayPort cable removal and locking bar.

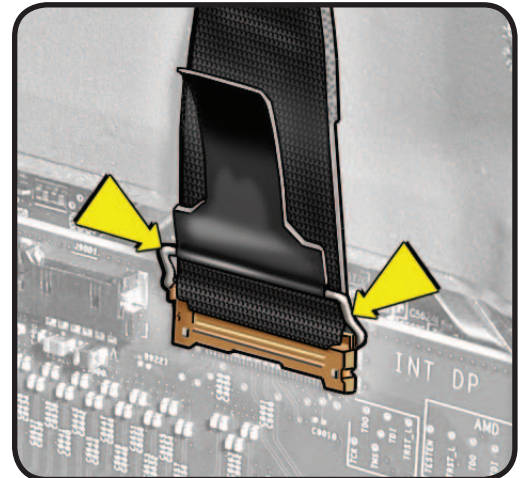
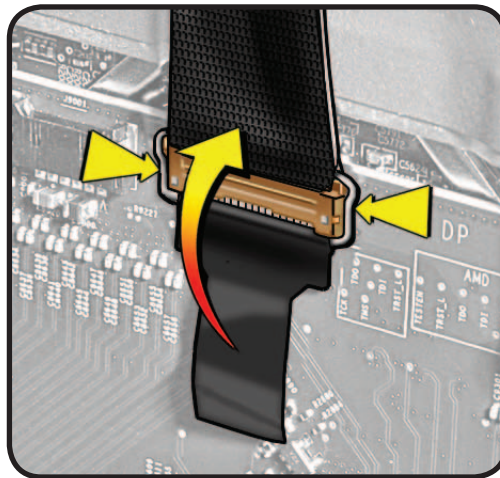

- 4 Lift LCD panel off rear housing.

### Important:

- Handle panel by edges only
- Use two hands to lift and move the panel
- Never hold panel with only one hand
- Don't touch the panel surface

### Replacement Note:

A new LCD panel includes the following cables:

- v-sync/temp sensor
- backlight power
- DisplayPort power

Transfer the DisplayPort cable from old LCD panel.

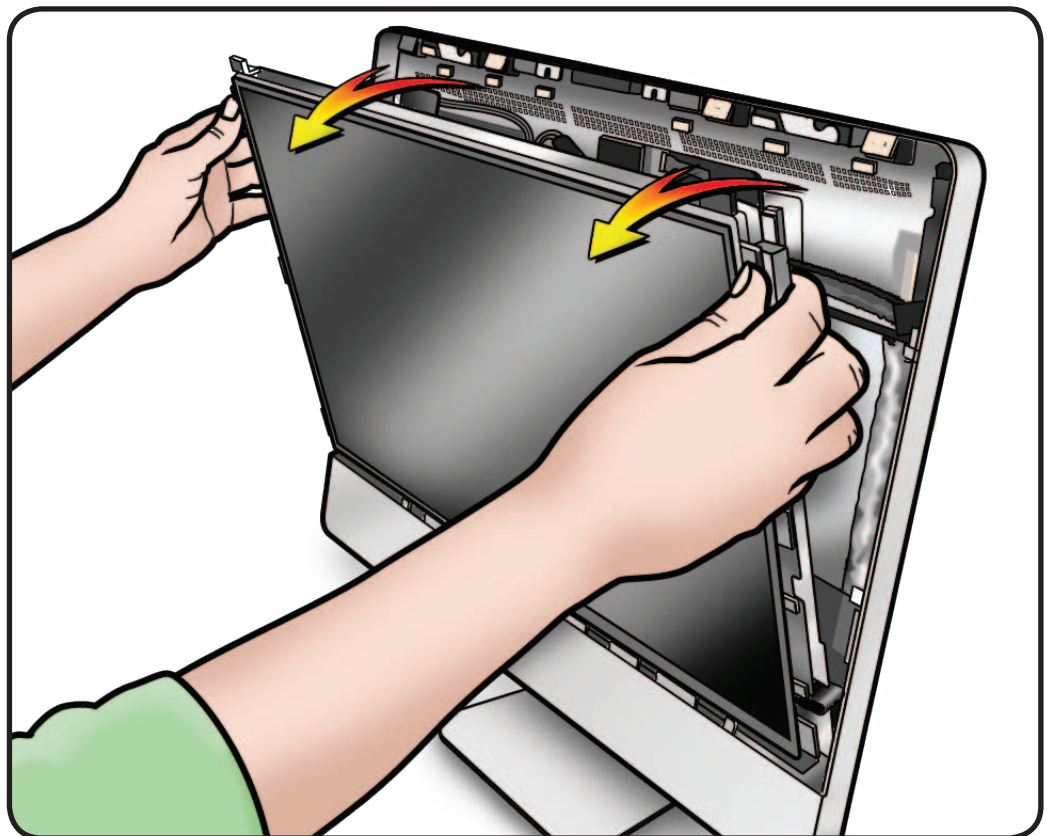



## Handling LCD Panel

- 1 Important:** Handle LCD panel by edges only.

Use two hands to carry the panel.

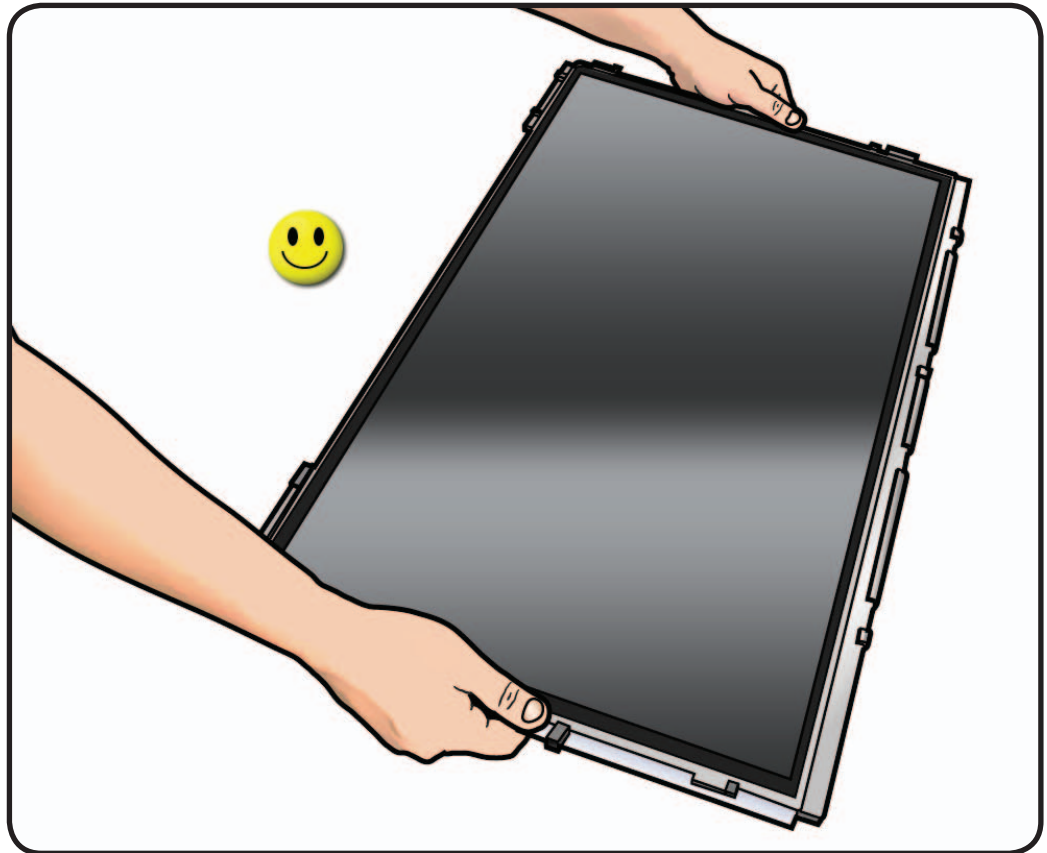

- 2** Never touch LCD surface or hold LCD panel with one hand. It could damage the LCD panel.

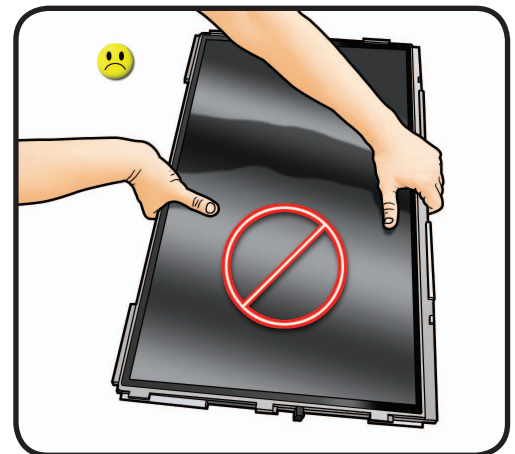
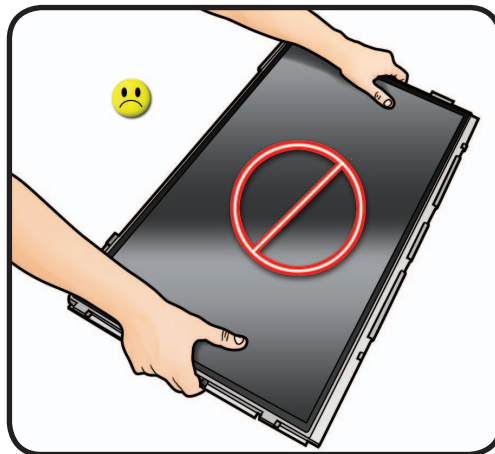



- 3 To prevent buildup of static charges which may attract dust particles to the surface of the display, store LCD panel in an anti-static bag whenever it has been removed from computer.

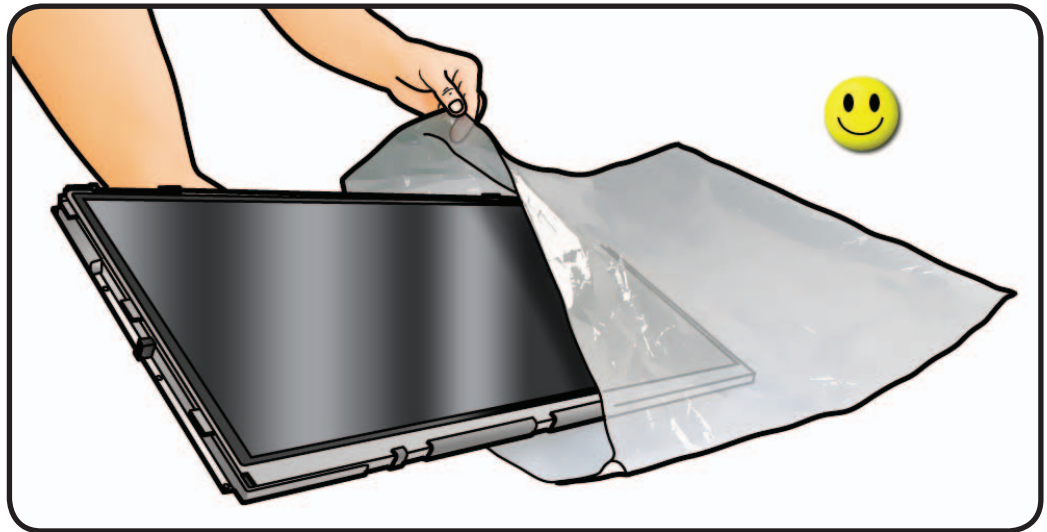

## Reassembly Tip

To avoid magnets grabbing screws while reassembling:

- 1 Wrap a short piece of tape around the screwdriver and screw as shown.

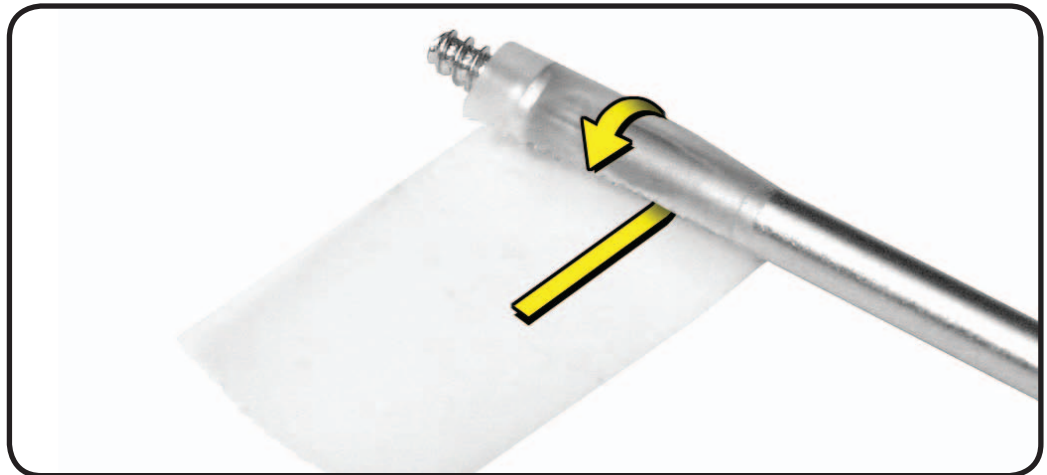

- 2 Hold on to the end of the tape. As you tighten the screw, the tape will unwind.

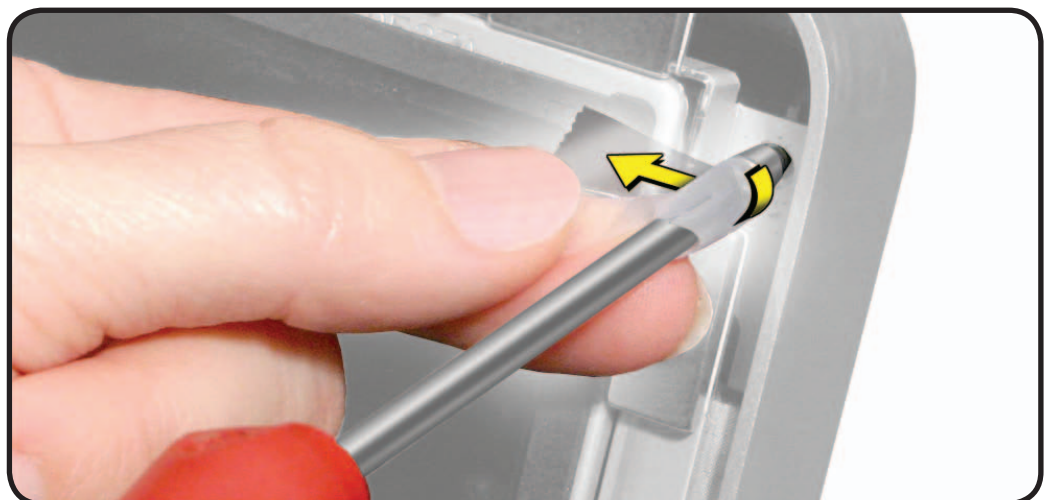



# Vertical Sync (V-Sync)/ Temp Sensor Cable

## First Steps

Remove:

- Glass Panel
- LCD Panel

**Note:** A new LCD panel includes a new v-sync/ temp sensor cable.

**Replacement Note:**

A new v-sync/temp sensor cable includes a new foam gasket.

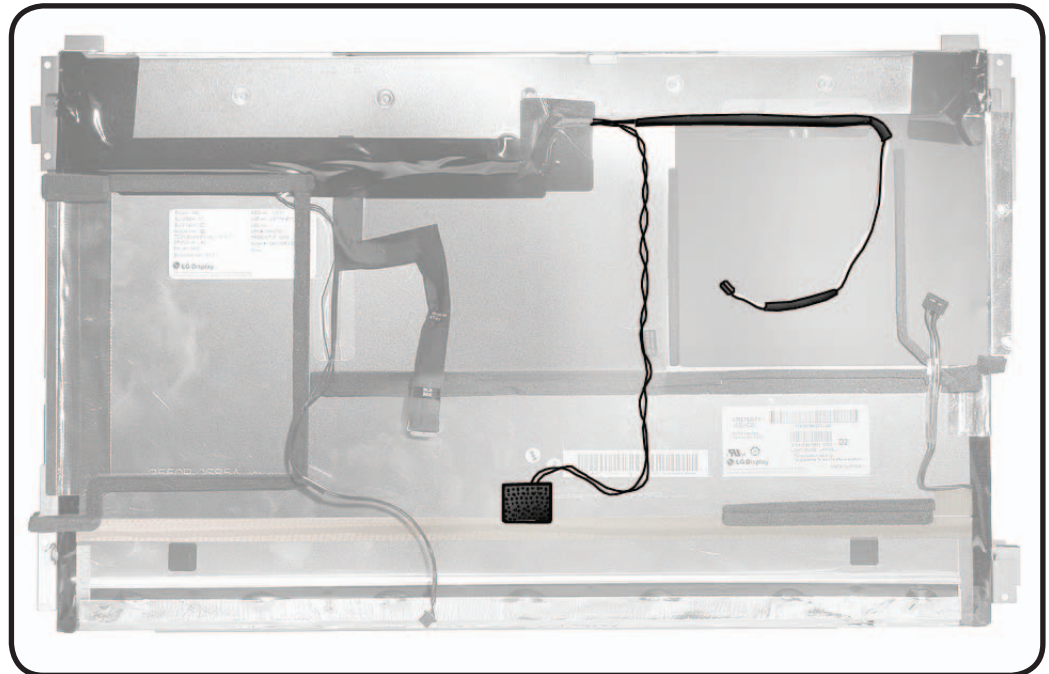

## Tools

- ESD wrist strap





## Removal

- 1 Note cable routing and placement of tape that secures cable to back of LCD panel.

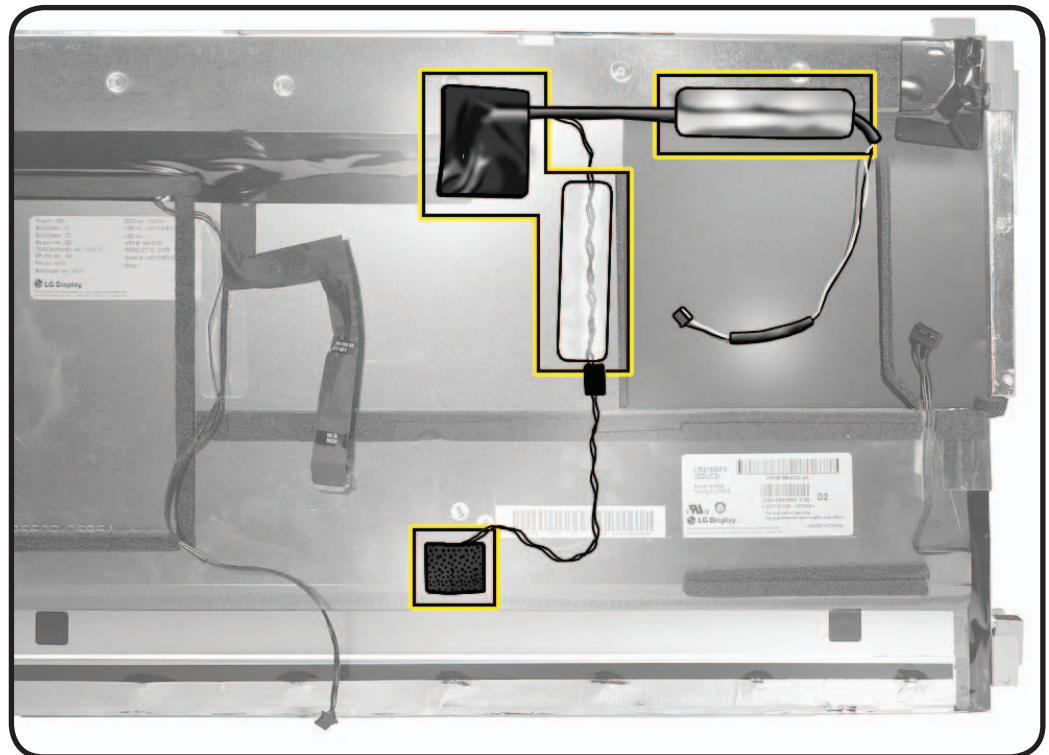

- 2 Peel back black mylar covering connector.
- 3 Pull cable straight out of connector.

### Reassembly Note:

Insert cable securely into connector and cover with black mylar tape.

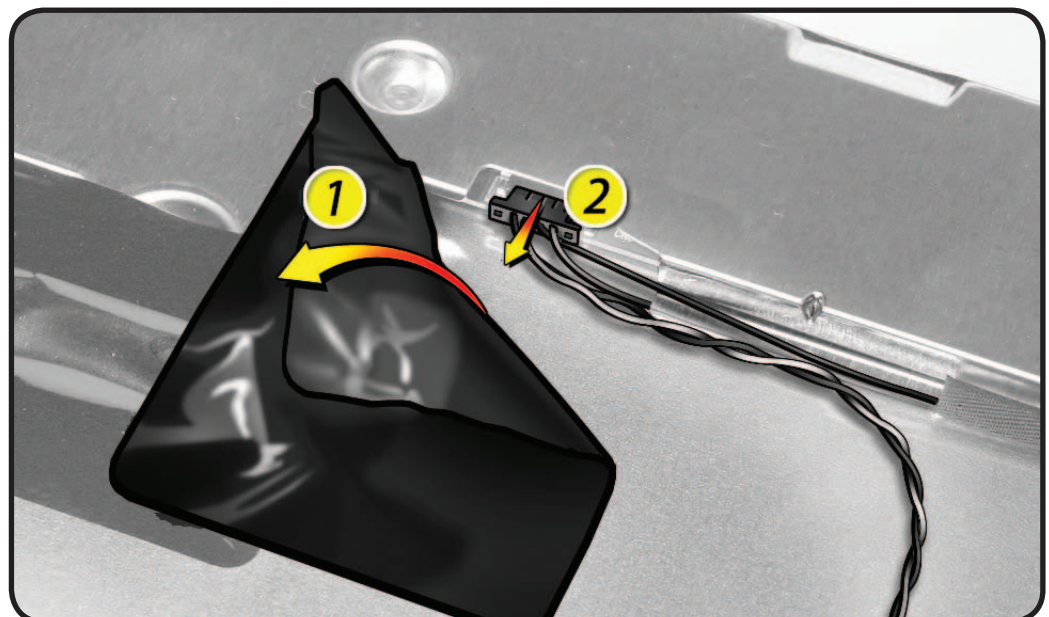



**4** Completely remove foam gasket covering temp sensor.

**5** Remove temp sensor from LCD panel.

**Replacement Note:**

Peel and stick new sensor and fully cover with new gasket to isolate sensor from internal air temperature.

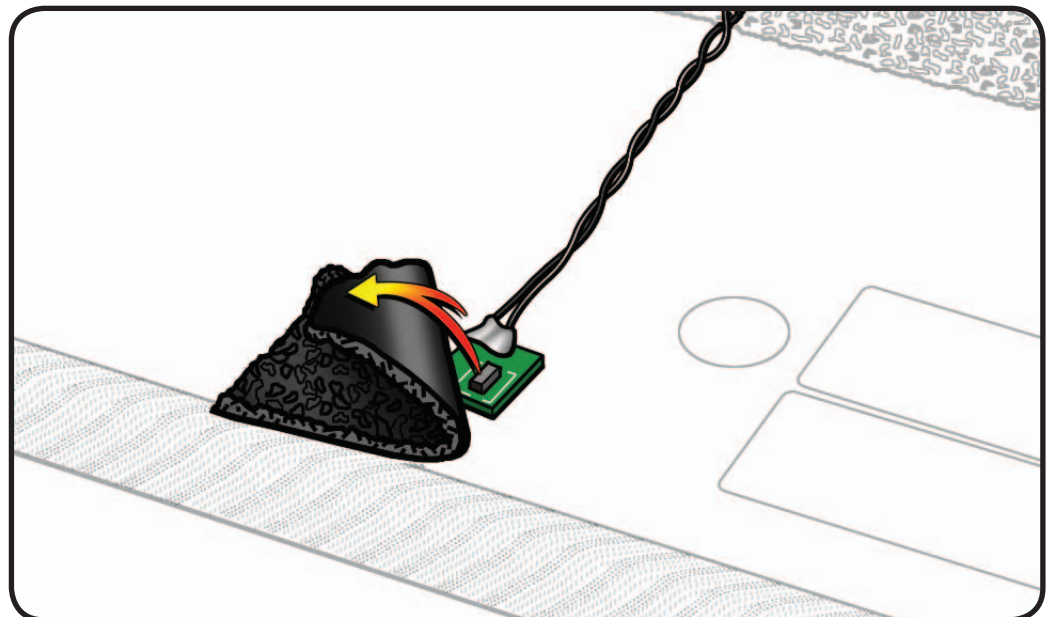



# DisplayPort Cable

## First Steps

Remove:

- Glass Panel
- LCD Panel

### Replacement Note:

A new DisplayPort cable includes \_\_\_\_\_.

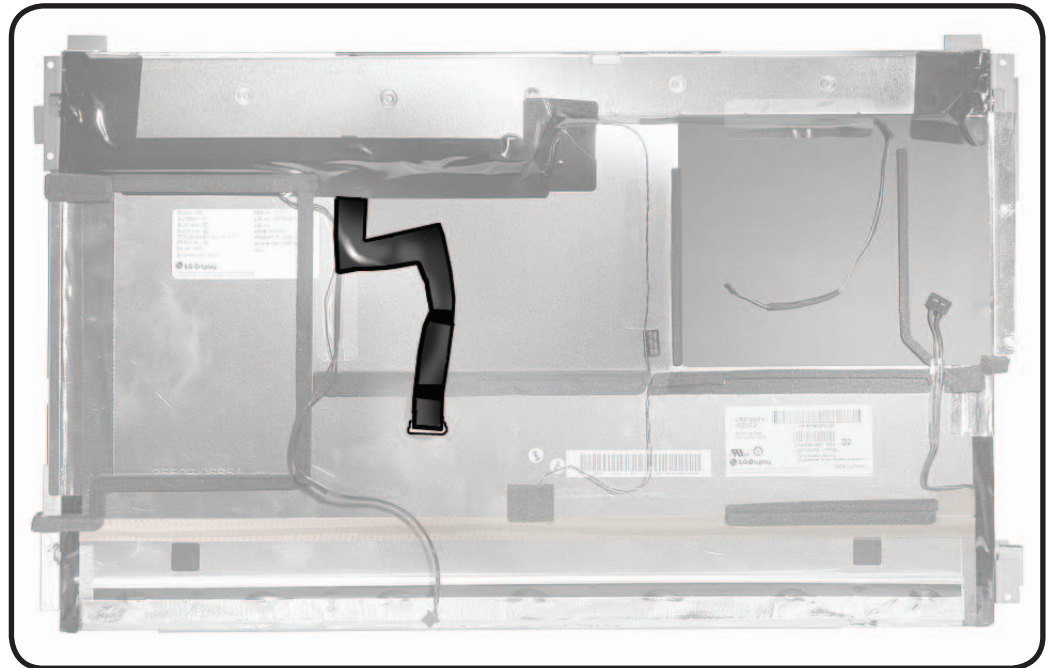

## Tools

- ESD wrist strap





## Removal

- 1** Peel back black mylar tape covering connector.
- 2** Flip up locking bar to release cable from connector.
- 3** Pull cable straight out of connector.

**Reassembly Note:**  
Insert cable fully into connector, flip down locking bar to secure cable, and replace all mylar tape.

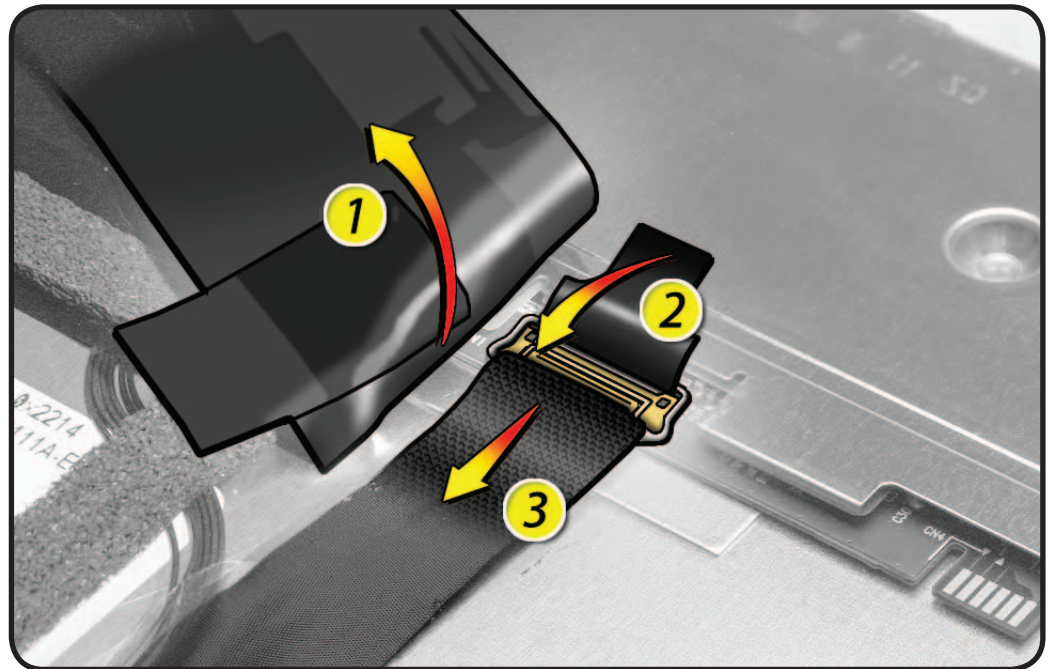



# DisplayPort Power Cable

## First Steps

Remove:

- Glass Panel
- LCD Panel

**Note:** A new LCD panel includes a new DisplayPort power cable.

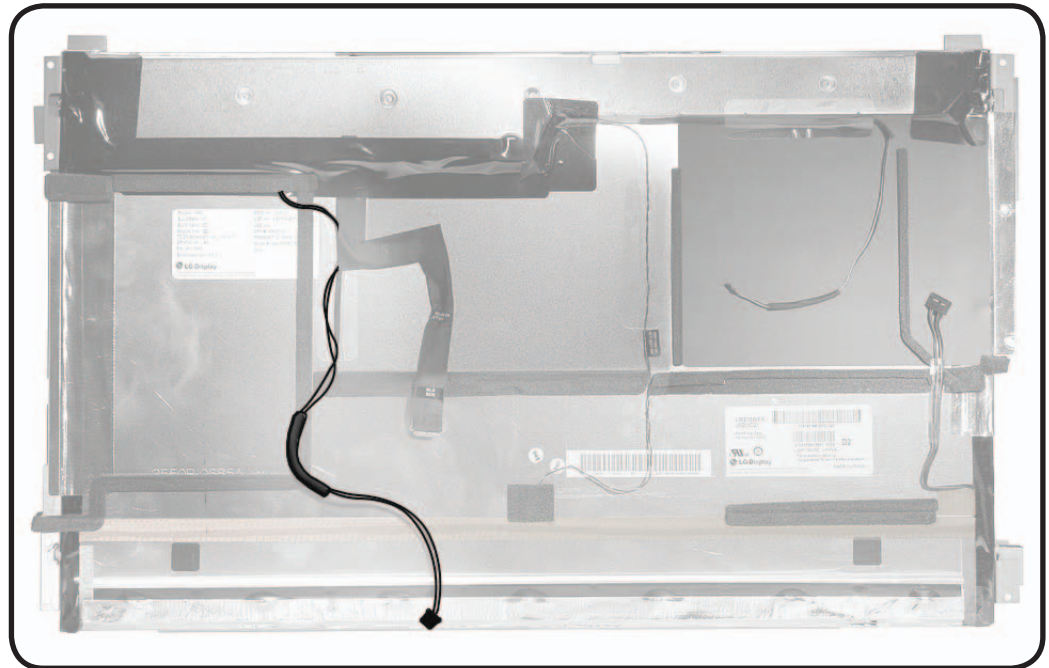

## Tools

- ESD wrist strap





## Removal

- 1 Peel back black mylar tape & foam covering connector.
- 2 Pull cable straight out of connector.
- 3 Peel up clear tape and remove cable from LCD panel.

### Reassembly Note:

Insert cable fully into connector and cover with black mylar tape. Route cable on back of LCD panel and secure with clear or Kapton tape.

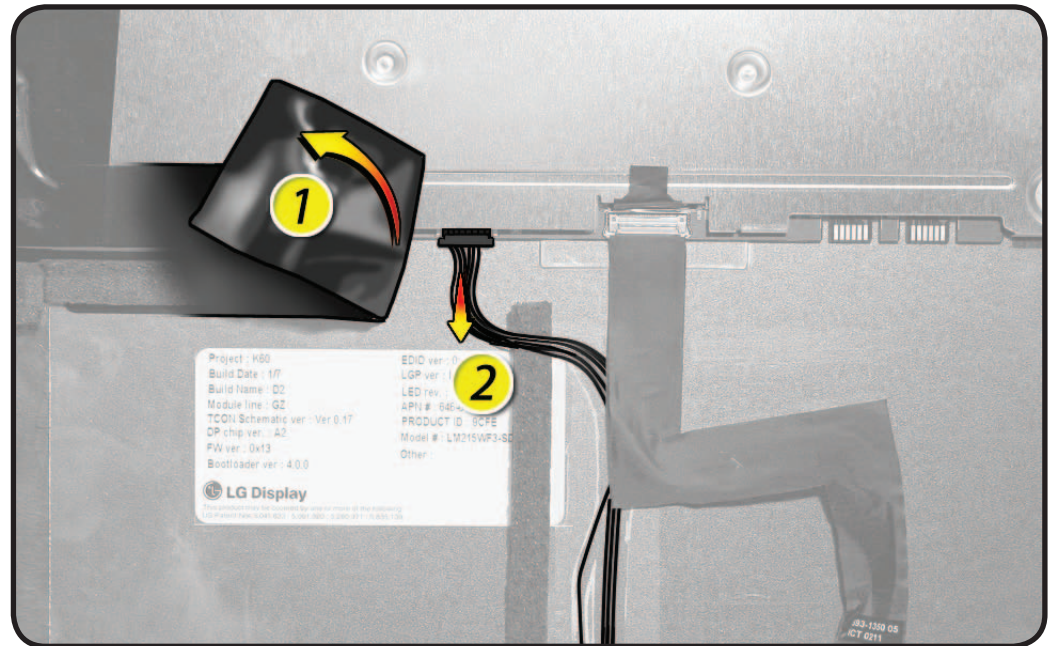



# Battery

## First Steps

Remove:

- Glass Panel
- LCD Panel

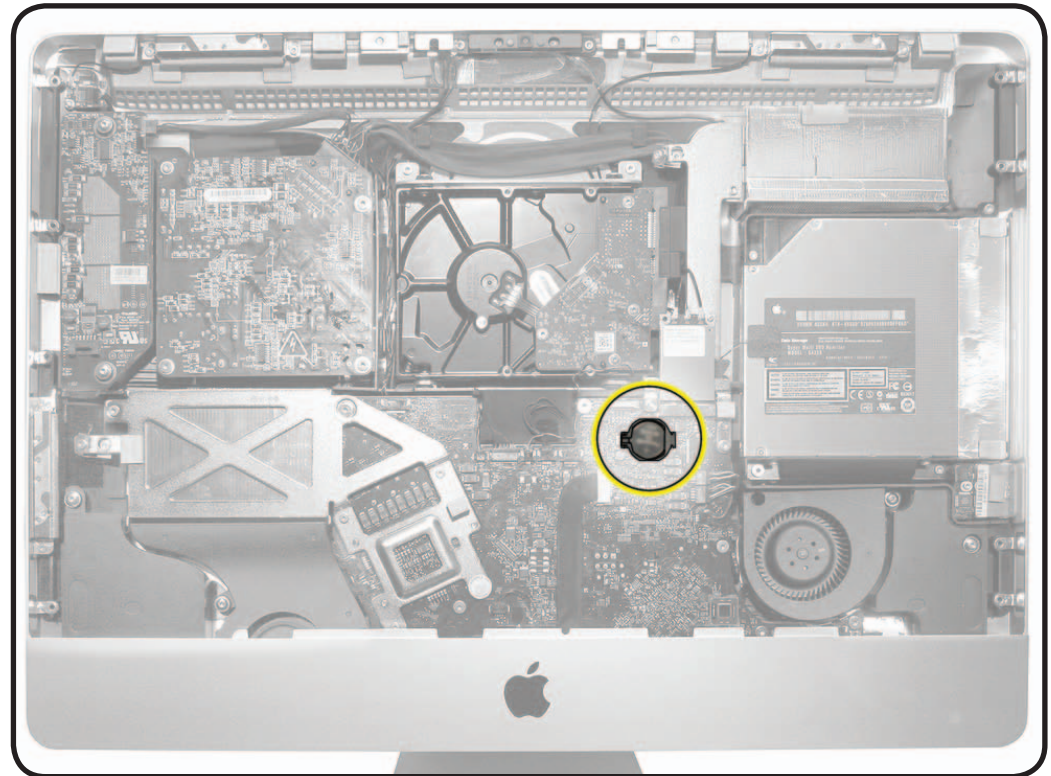

## Tools

- ESD wrist strap
- Black stick





## Removal

- 1 Use a black stick to pry battery from socket on front side of logic board. The battery will spring out of the socket.

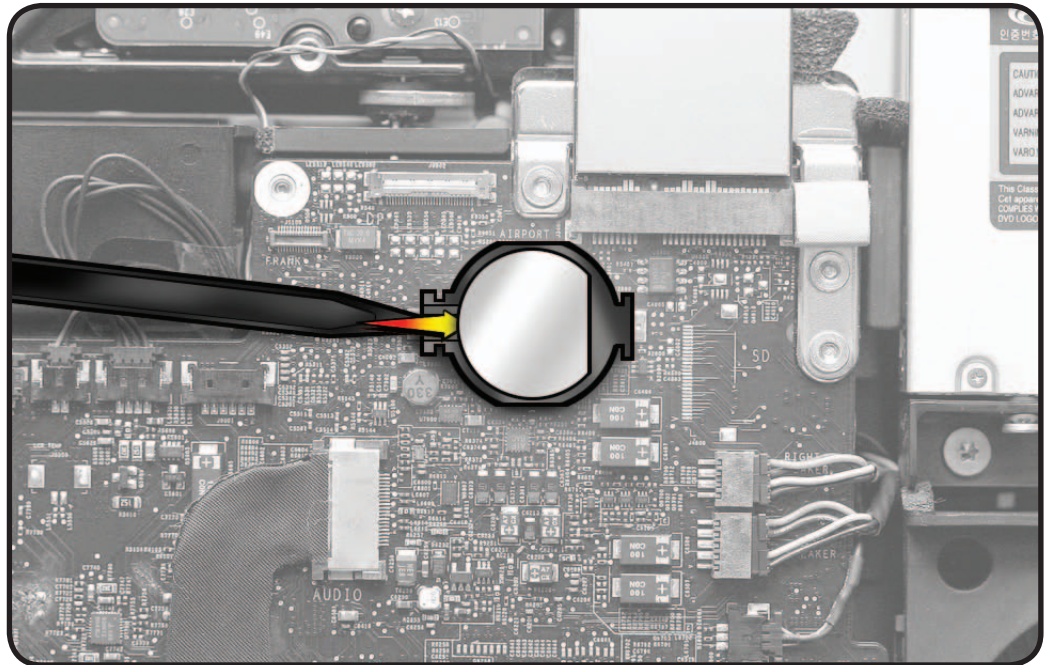

## Reassembly

- 1 Make sure battery socket is open and free of dust.
- 2 Press battery into socket with engraved markings (+ side) facing up.





# AirPort Card

## First Steps

Remove:

- Glass Panel
- LCD Panel



## Tools

- ESD wrist strap
- Torx T6 screwdriver

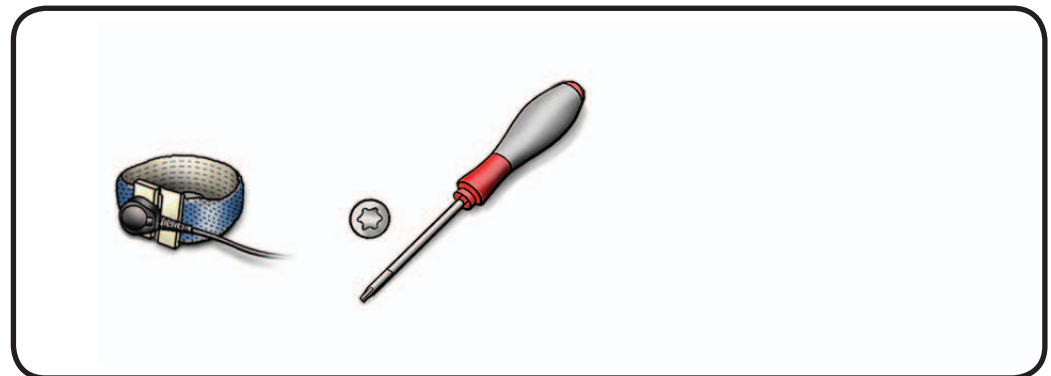



## Removal

- 1 Remove T6 screw:  
(1) 922-8579



- 2 Disconnect 3 antenna cables.

**Caution:** Be careful not to damage antenna connectors as it may induce antenna or rear housing replacement (one antenna is part of rear housing).



- 3 (1) Tilt AirPort card away from logic board, then (2) hold card by edges and pull it out of the slot.

**Reassembly Note:** Card must be inserted at this angle.

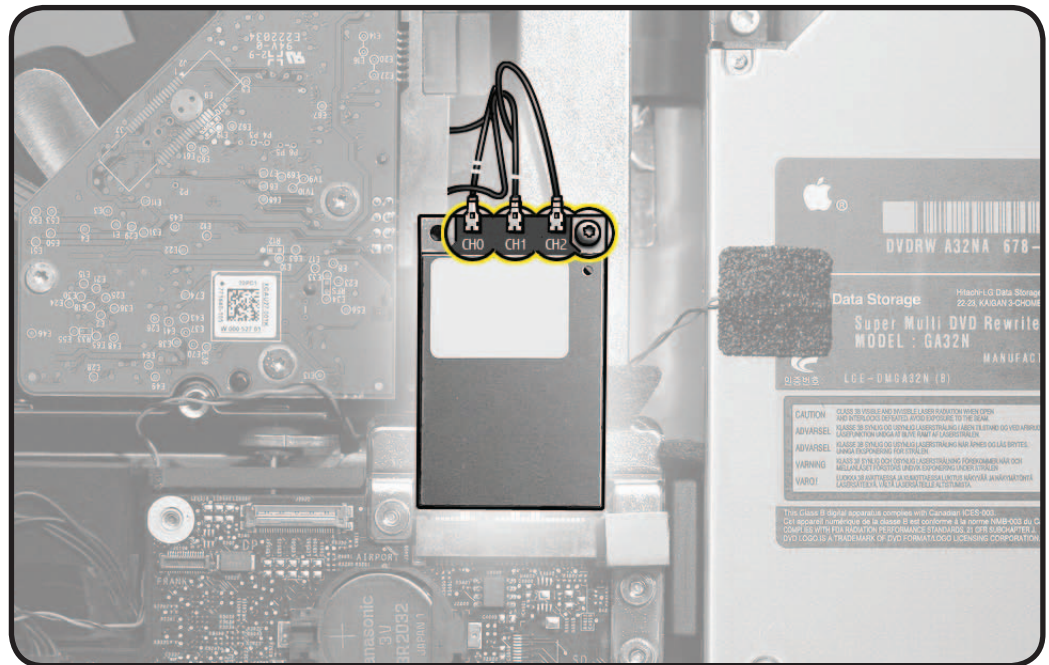

**Reassembly Note:** The three black AirPort antenna cables are marked with 0, 1, or 2 light stripes. The cable lengths are designed to attach to specific connectors.

- Cable with **2 stripes** attaches to **CH0** connector.
- Cable with **1 stripe** attaches to **CH1** connector.
- Cable with **0 stripes** attaches to **CH2** connector.

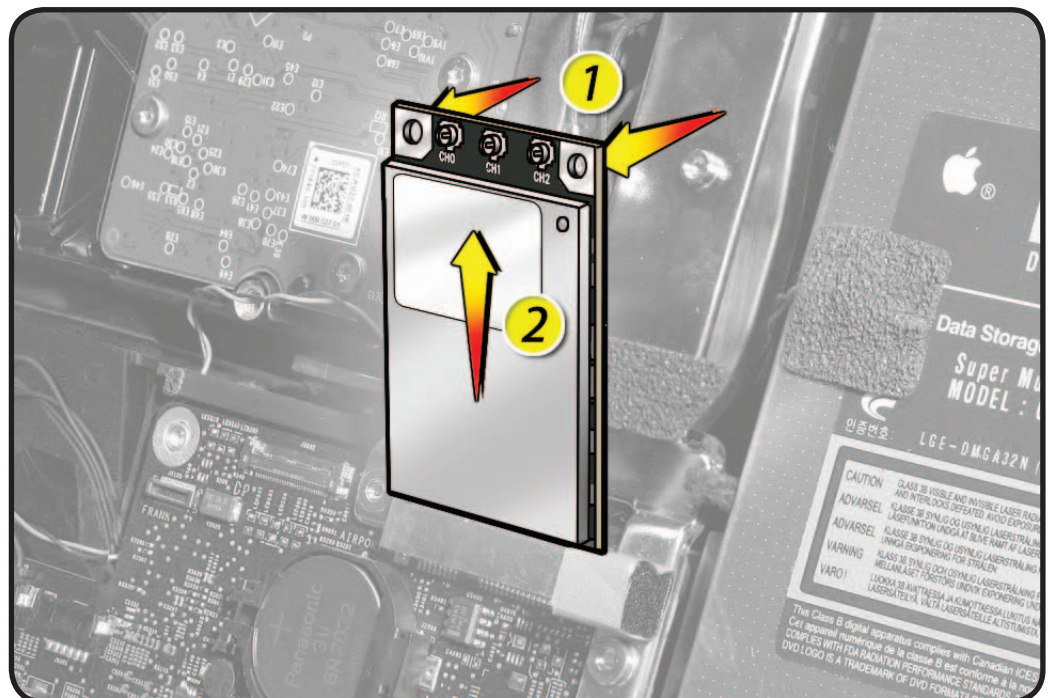



# Bluetooth Board

## First Steps

Remove:

- Glass Panel
- LCD Panel

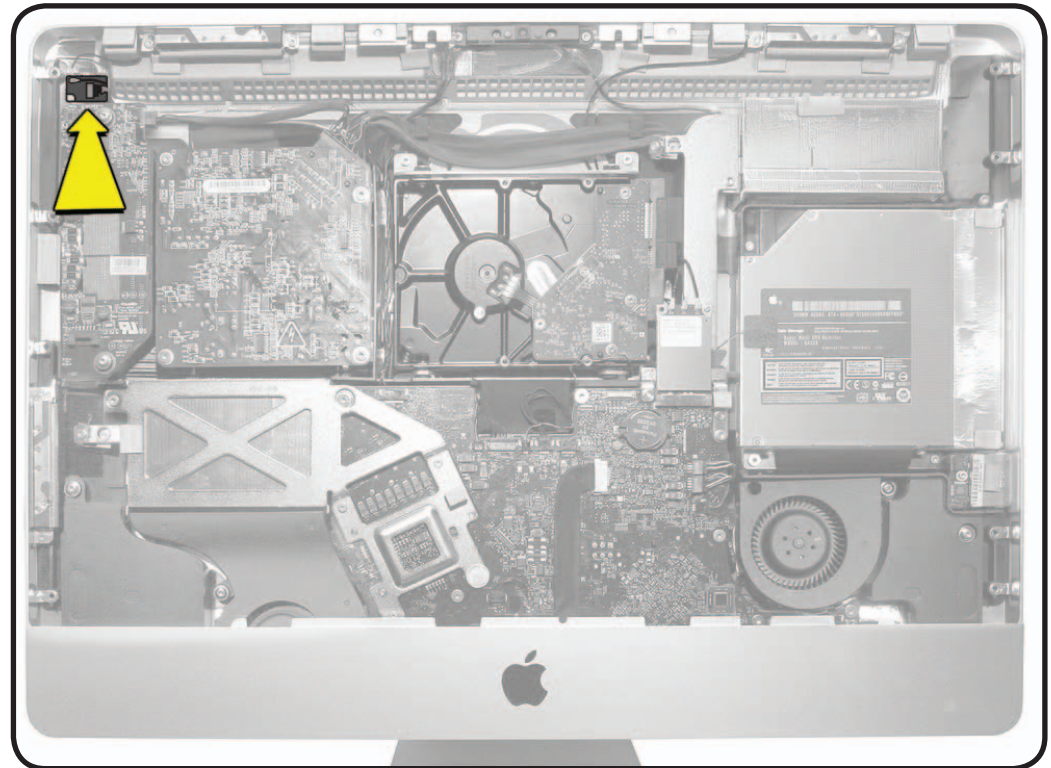

## Tools

- ESD wrist strap
- Torx T8 screwdriver

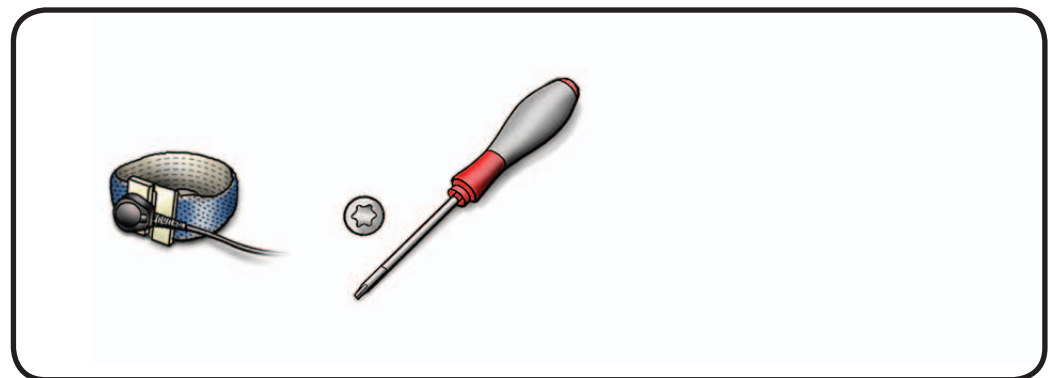



## Removal

- 1 Remove T8 screw:  
(1) 922-9247



- 2 Disconnect antenna cable.

**Caution:** Be careful not to damage antenna connector as it may induce antenna replacement.

- 3 Disconnect Bluetooth/camera/sensor cable.

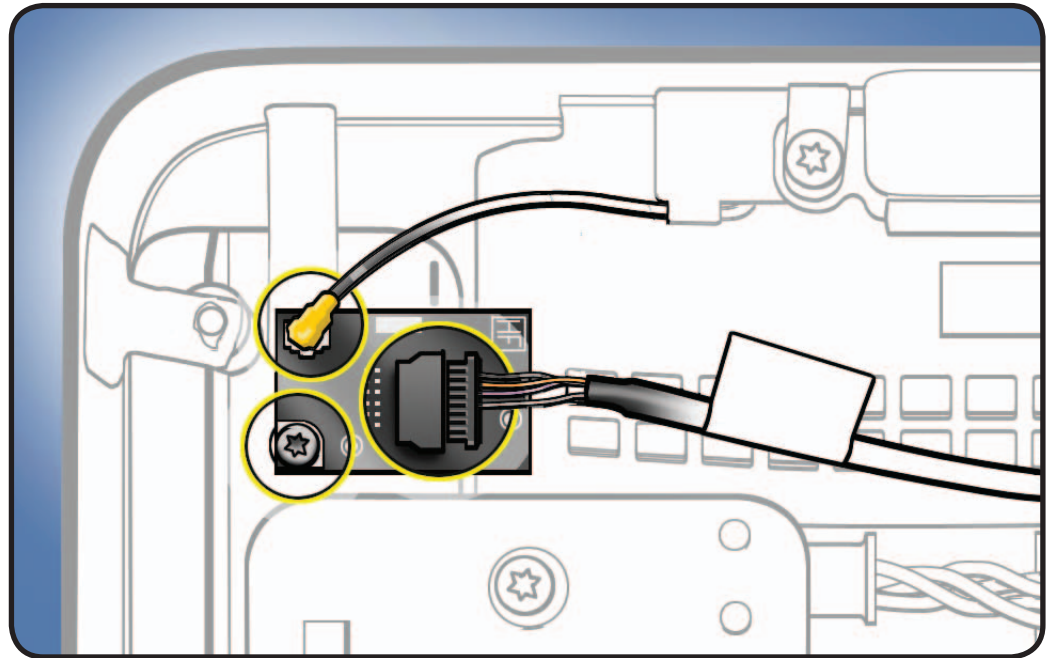



# Bluetooth Antenna

## First Steps

Remove:

- Glass Panel
- LCD Panel

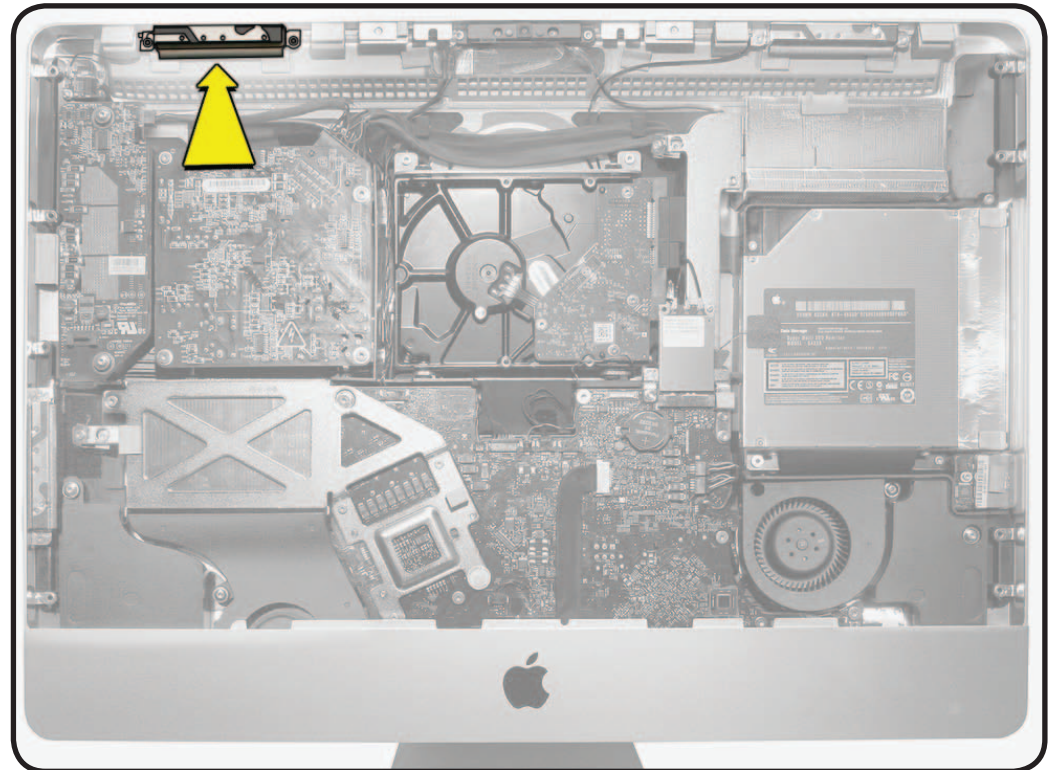

## Tools

- ESD wrist strap
- Torx T8 screwdriver

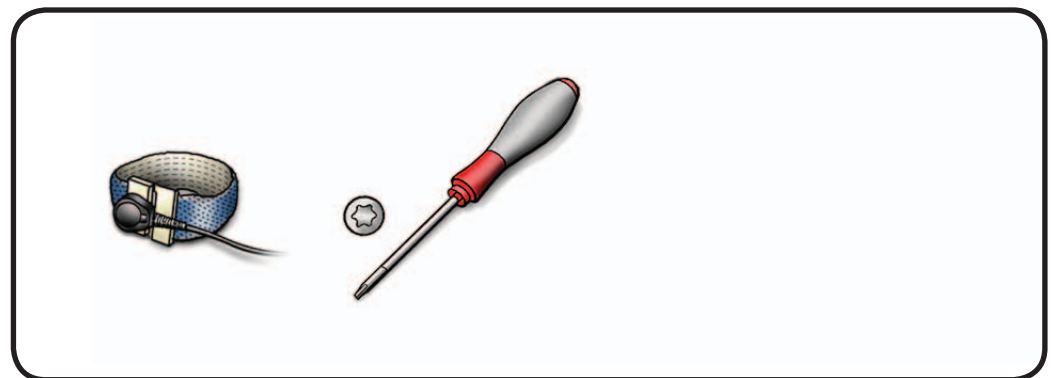



## Removal

- 1 Remove T8 screws:  
(2) 922-4723



- 2 Disconnect antenna  
cable from Bluetooth  
board.

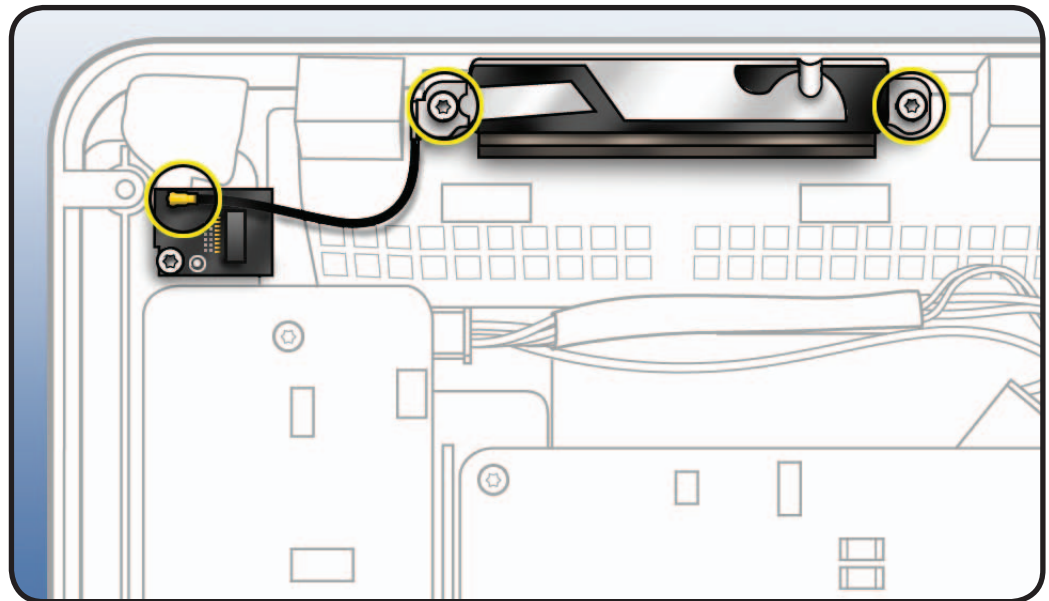



# Camera

## First Steps

Remove:

- Glass Panel
- LCD Panel

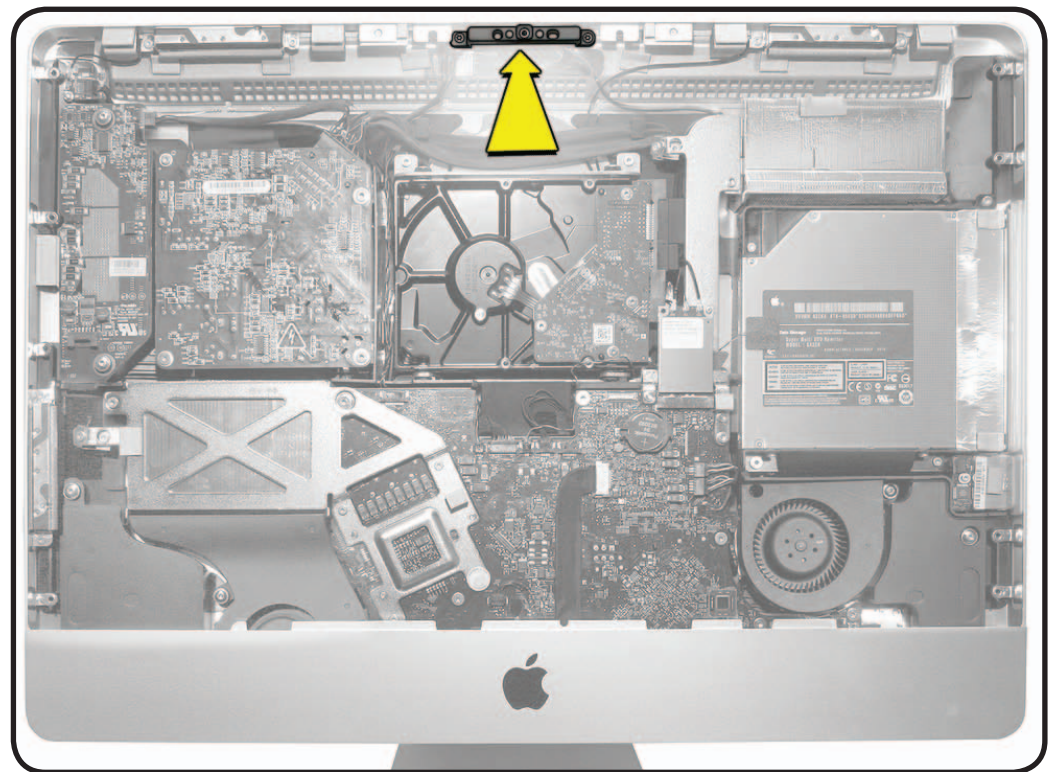

## Tools

- ESD wrist strap
- Torx T10 screwdriver
- Black stick

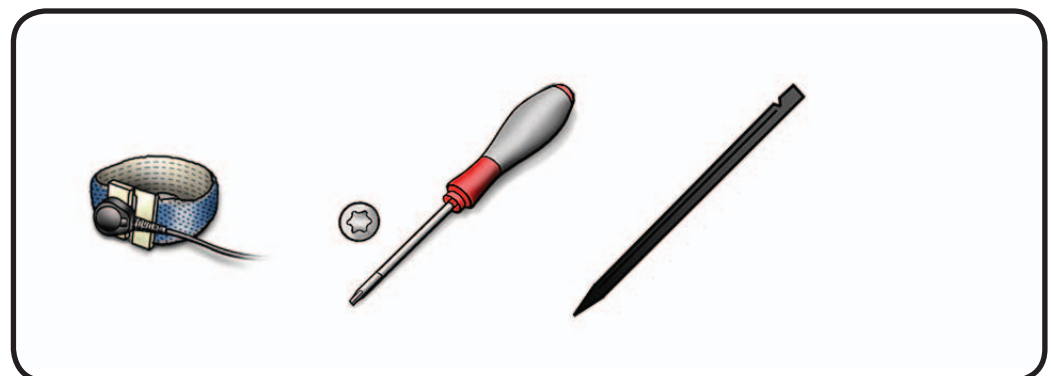



## Removal

- 1 Remove T10 screws:  
(2) 922-9239

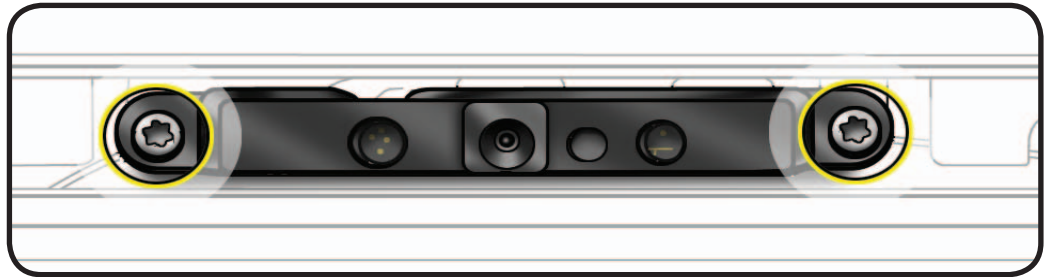

- 2 Lift camera out of rear housing.
- 3 Disconnect cable from camera.

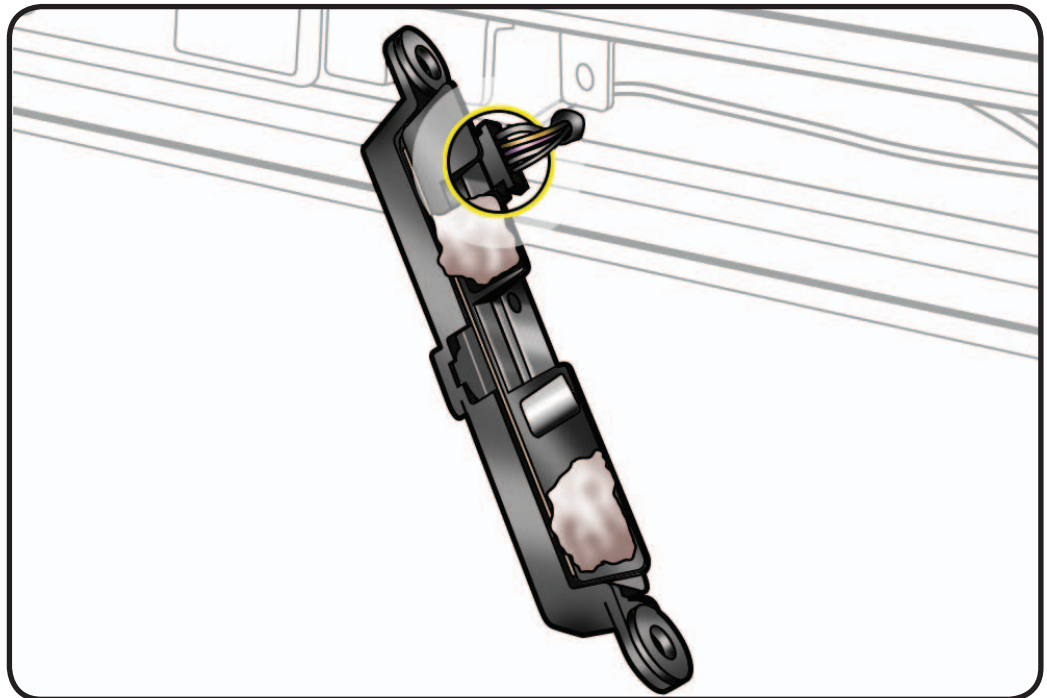



## Reassembly

- 1 Thermal material is required between camera and rear housing. Reuse the thermal material.
- 2 Use a black stick to remove and reapply thermal material to camera (areas circled).

**Note:** A syringe of thermal material is available as needed, Apple part# 922-9625, good for 5 applications.

**Important:** The white thermal material used on camera should NOT be used for any other purpose (such as portable computer heat sinks).

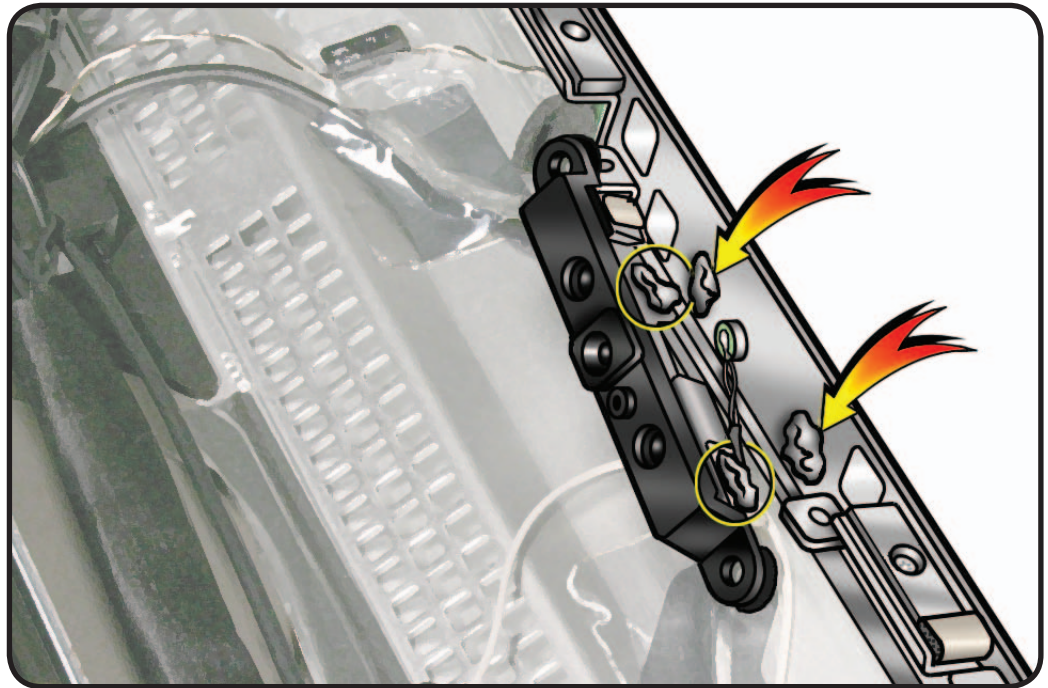



# LED Backlight Board

## First Steps

Remove:

- Glass Panel
- LCD Panel



**Warning:** HIGH VOLTAGE:

Use extreme caution when working around the capacitors in top right corner of backlight board, which contain high-voltage that may remain charged for several minutes even when computer is unplugged. Never touch leads on top side of backlight board.

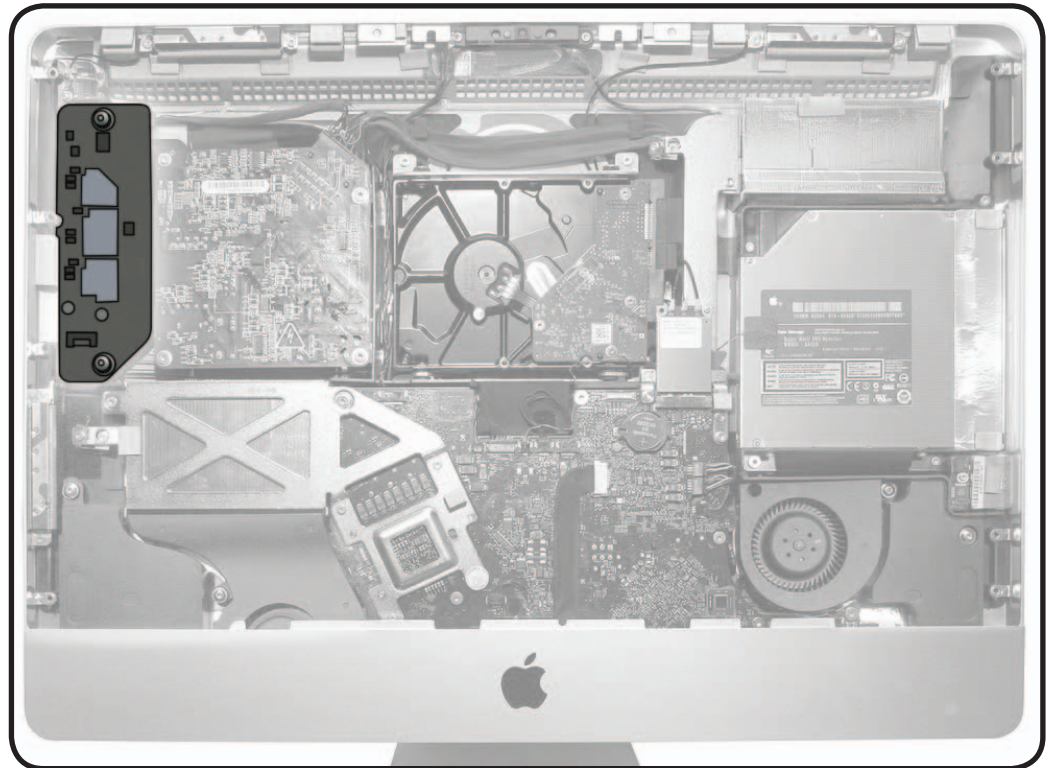

## Tools

- ESD wrist strap
- Torx T10 screwdriver

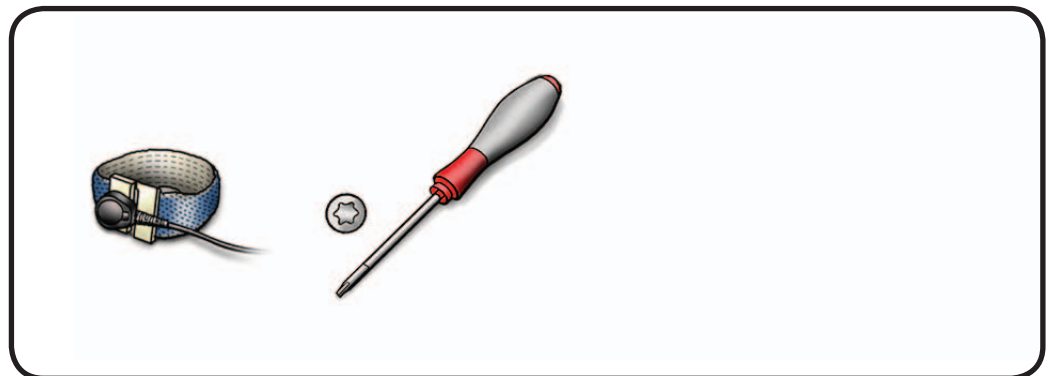



## Removal

Remove T10 screws:  
(2) 922-9901

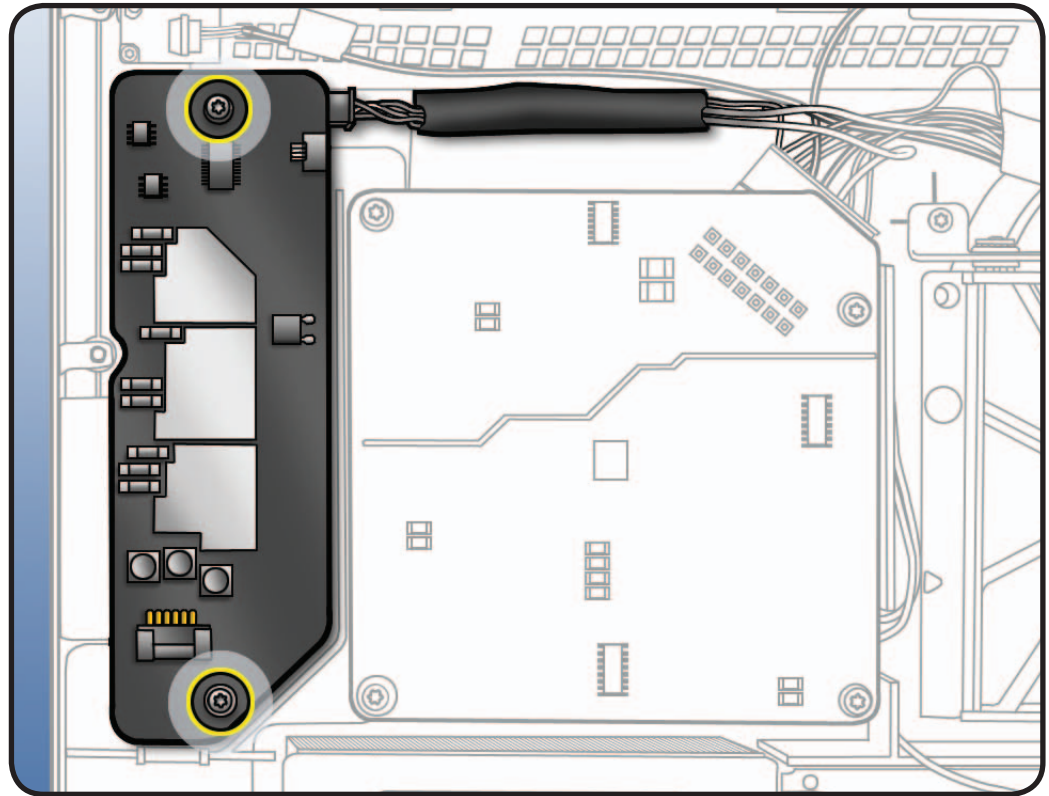

- 1 Lift up board, flip over, and disconnect power connector.

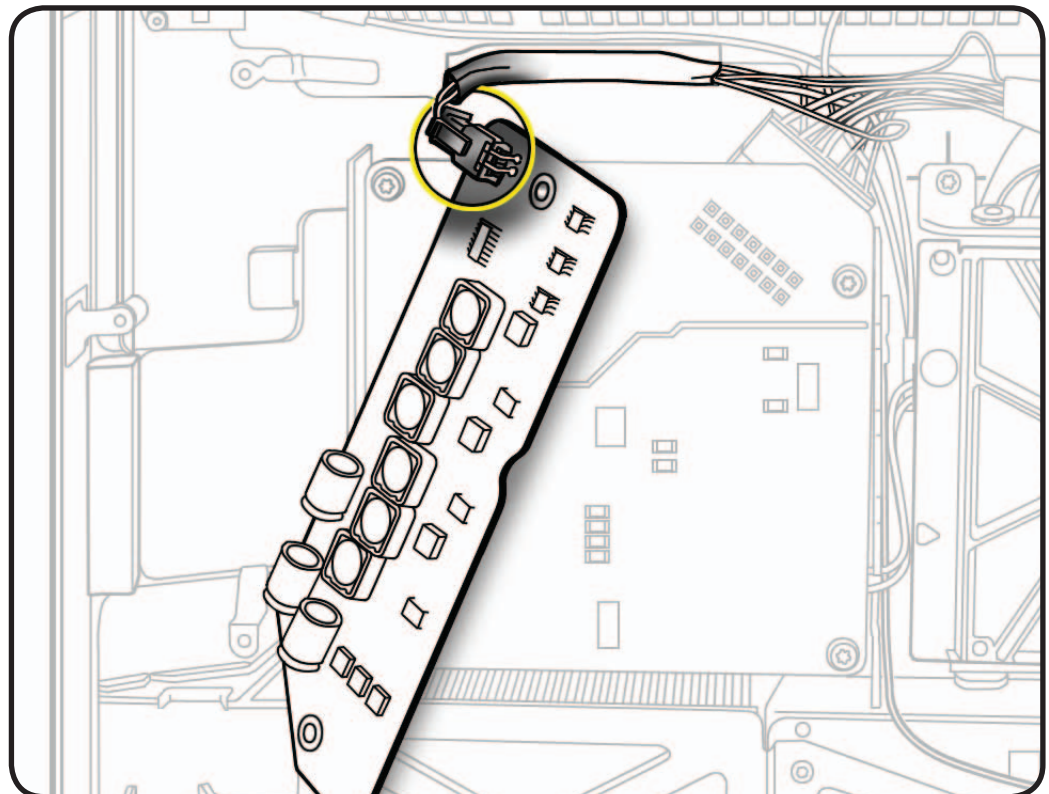



# Power Supply

## First Steps

Remove:

- Glass Panel
- LCD Panel



**Warning: HIGH VOLTAGE:**

Use extreme caution when working around the power supply, which contains a high-voltage capacitor that may remain charged for several minutes even when computer is unplugged. Never touch leads on top side of power supply, especially those near warning sign.

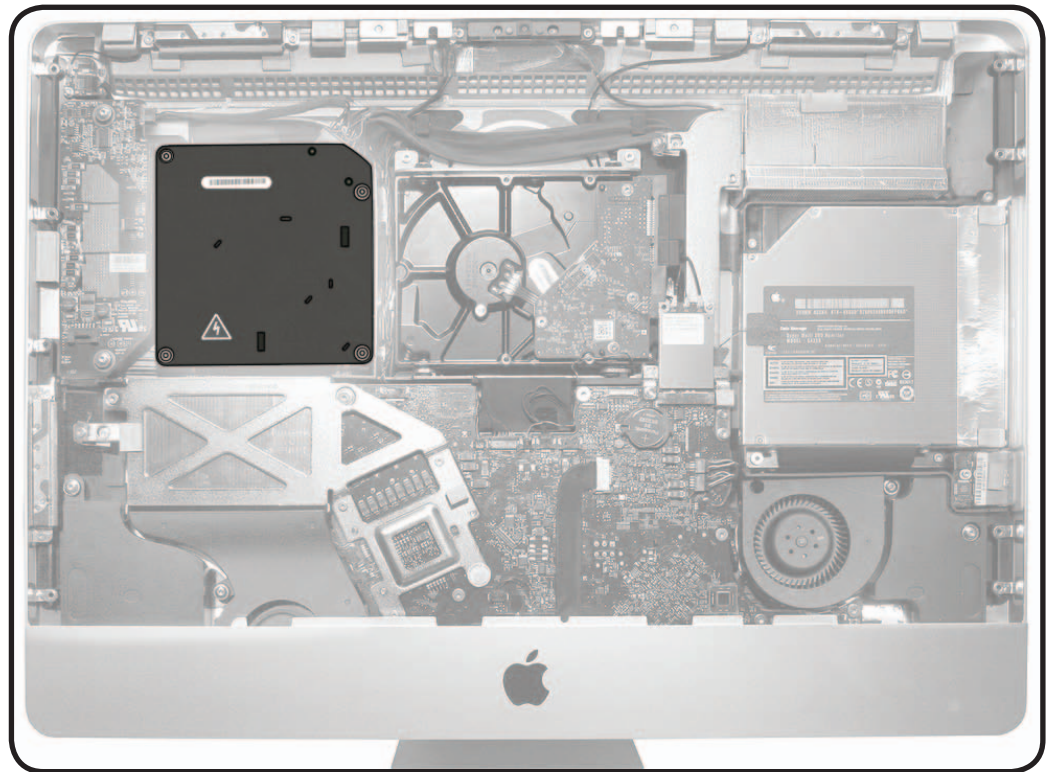

## Tools

- ESD wrist strap
- Torx T10 screwdriver

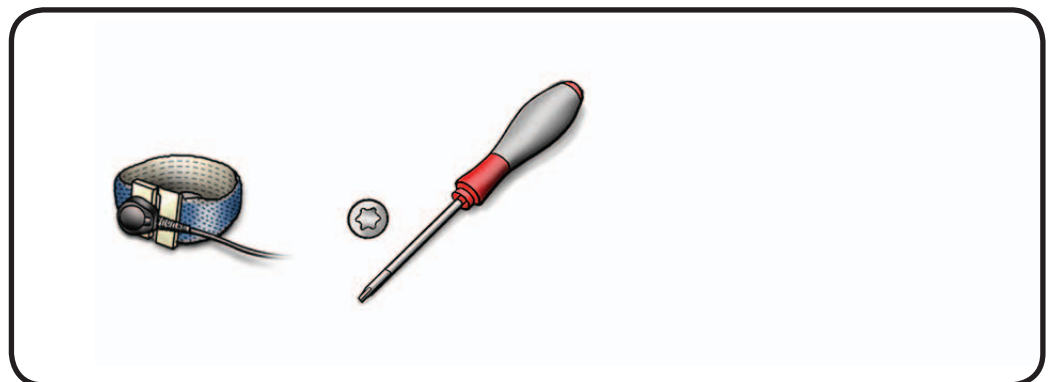



## Removal

### 1 Remove T10 screws:

- (1) 922-6850, short (S)



- (1) 922-9884, long (L)



- (2) 922-9244, machine, medium (M)

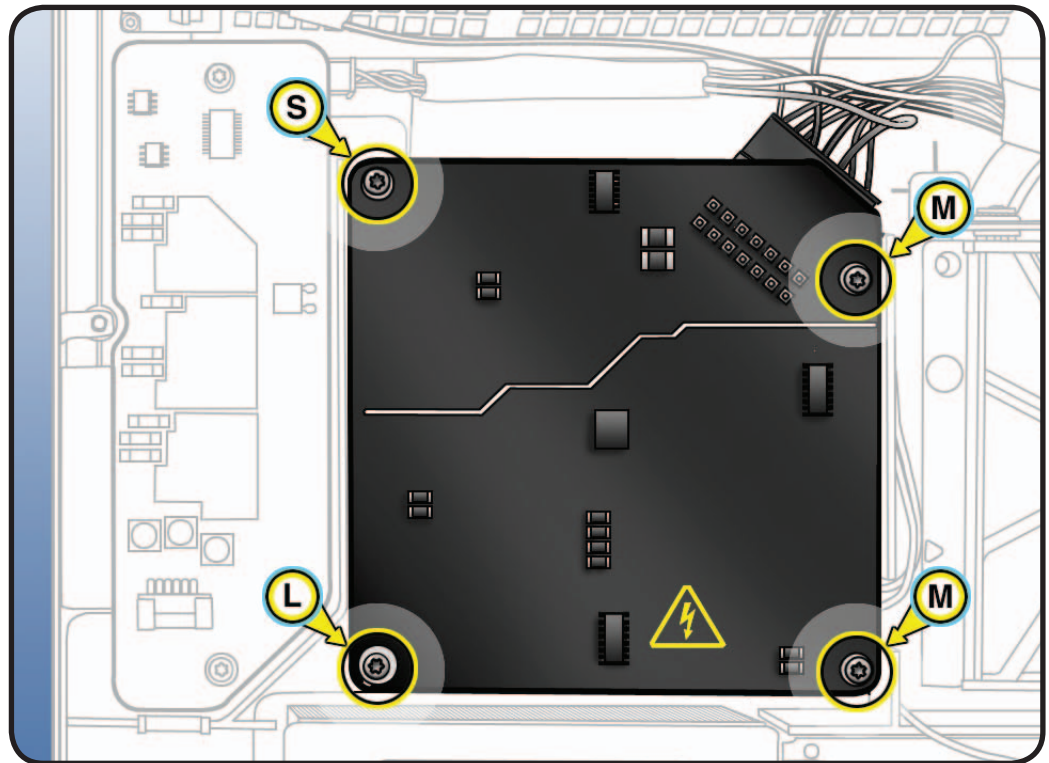

### 2 Lift up, flip over and disconnect 2 cables.

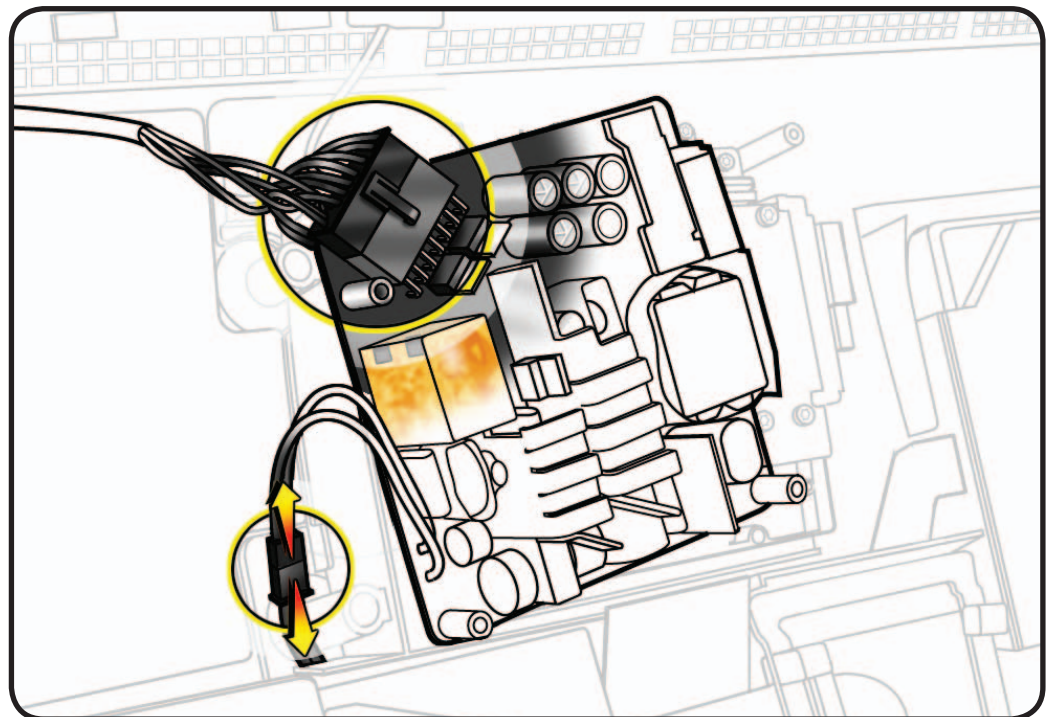



# Backlight Pressure Wall

## First Steps

Remove:

- Glass Panel
- LCD Panel
- Power Supply

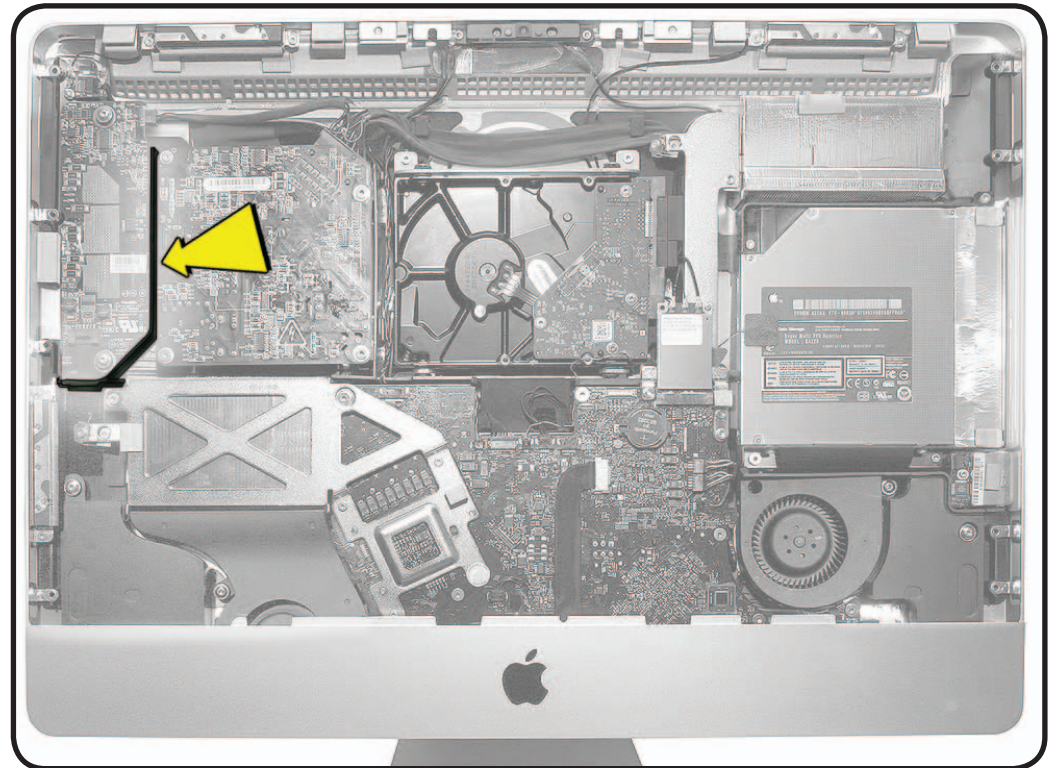

## Tools

- ESD wrist strap





## Removal

- 1 Lift pressure wall off posts in rear housing.

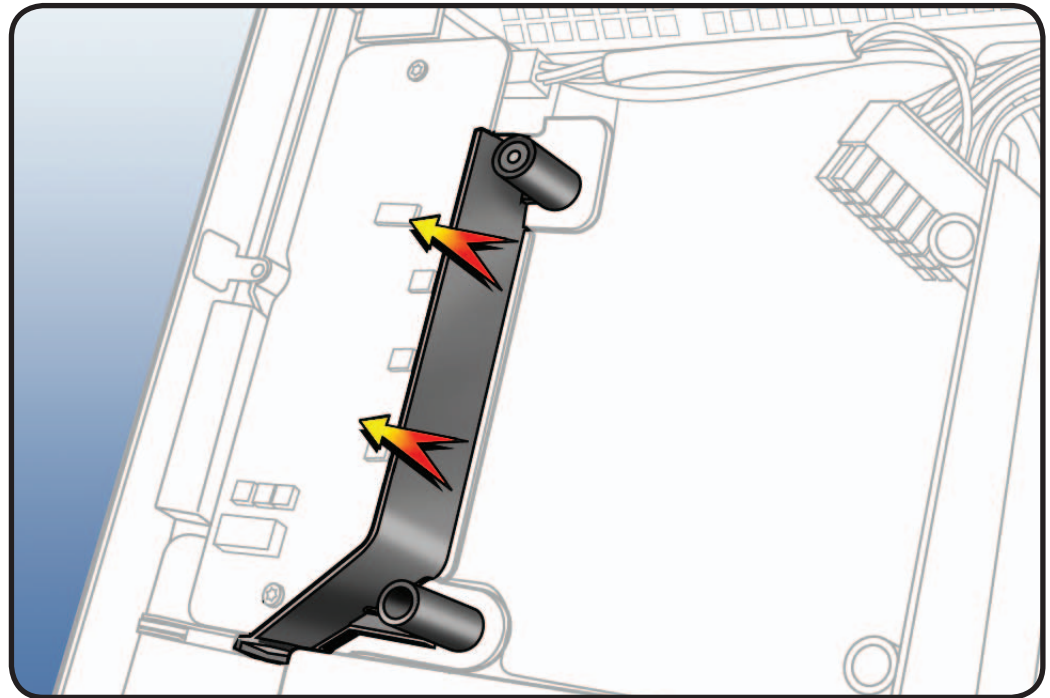



# Hard Disk Drive (HDD)

## First Steps

Remove:

- Glass Panel
- LCD Panel

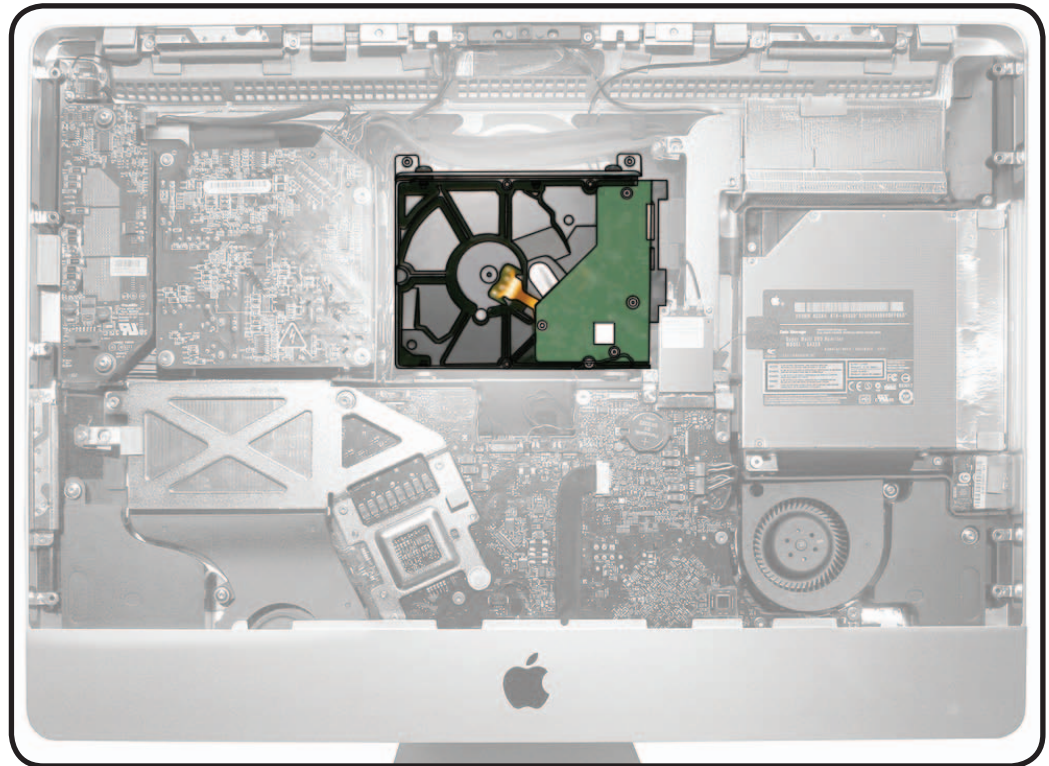

## Tools

- ESD wrist strap
- Torx T10 screwdriver
- Torx T8 screwdriver

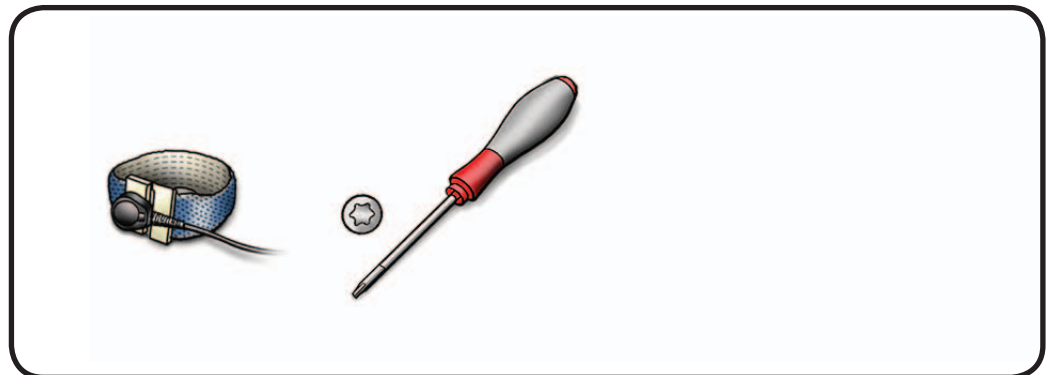



## Removal

- 1 Remove T10 screws:  
(2) 922-6850



- 2 Disconnect 2 cables:
  - HD power cable
  - HD data cable

**Note:** Unlike previous iMac models, there is no hard drive sensor cable.

- 3 Slide hard drive up slightly to lift pins out of 2 rubber grommets in hinge mechanism.

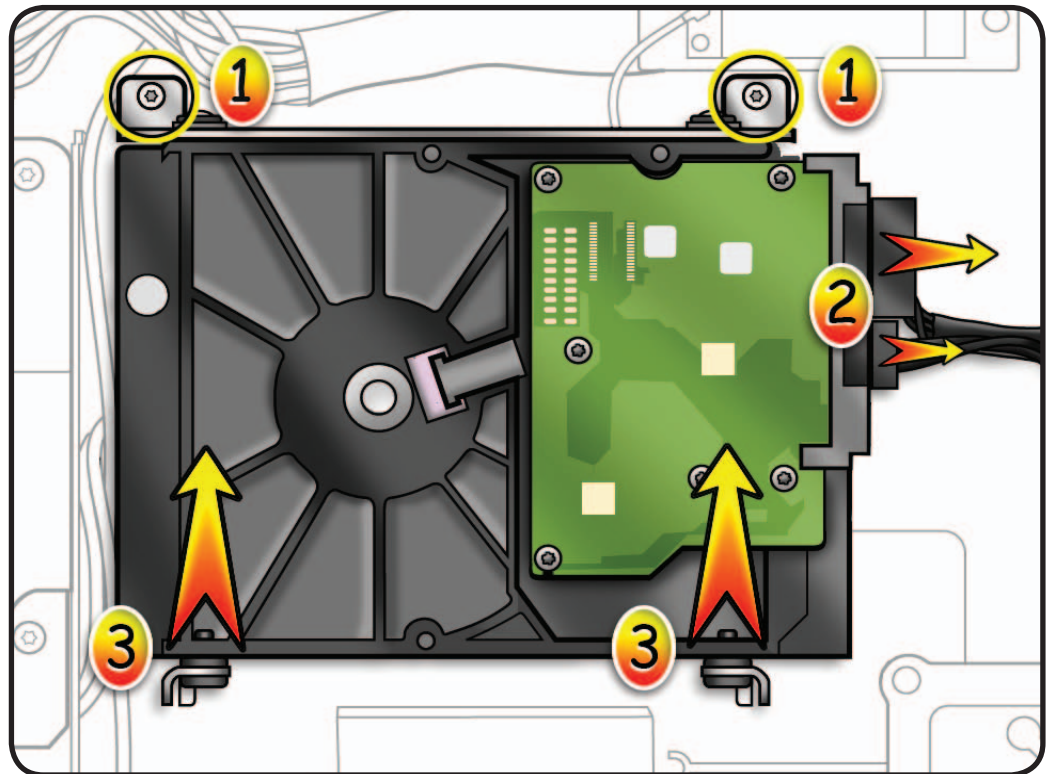



## Reassembly

### 1 Replacement Note:

If installing a new hard drive, transfer the following:

- hard drive bracket 922-9135
- (2) T8 screws 922-9136



- (2) T8 screw pins 922-7001

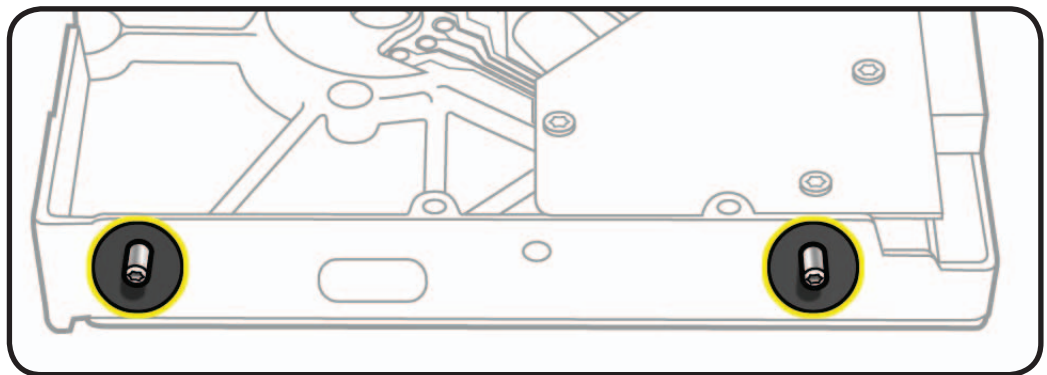
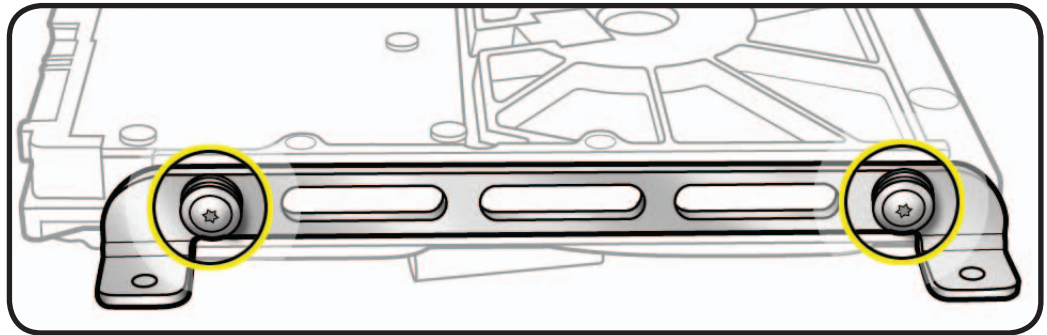

## Reinstalling Software That Came with the Computer

Use the original system media for this model to reinstall Mac OS X and any applications that came with the computer.

**Important:** Apple recommends backing up essential user files before restoring Mac OS X and other applications. Apple is not responsible for any lost data.

For more information, see Apple Support article

[HT3910: Mac OS X v10.6 Snow Leopard: How to Erase and Install](#)



# Power Supply Pressure Wall

## First Steps

Remove:

- Glass Panel
- LCD Panel
- Power Supply
- Hard Drive (if present in this configuration)

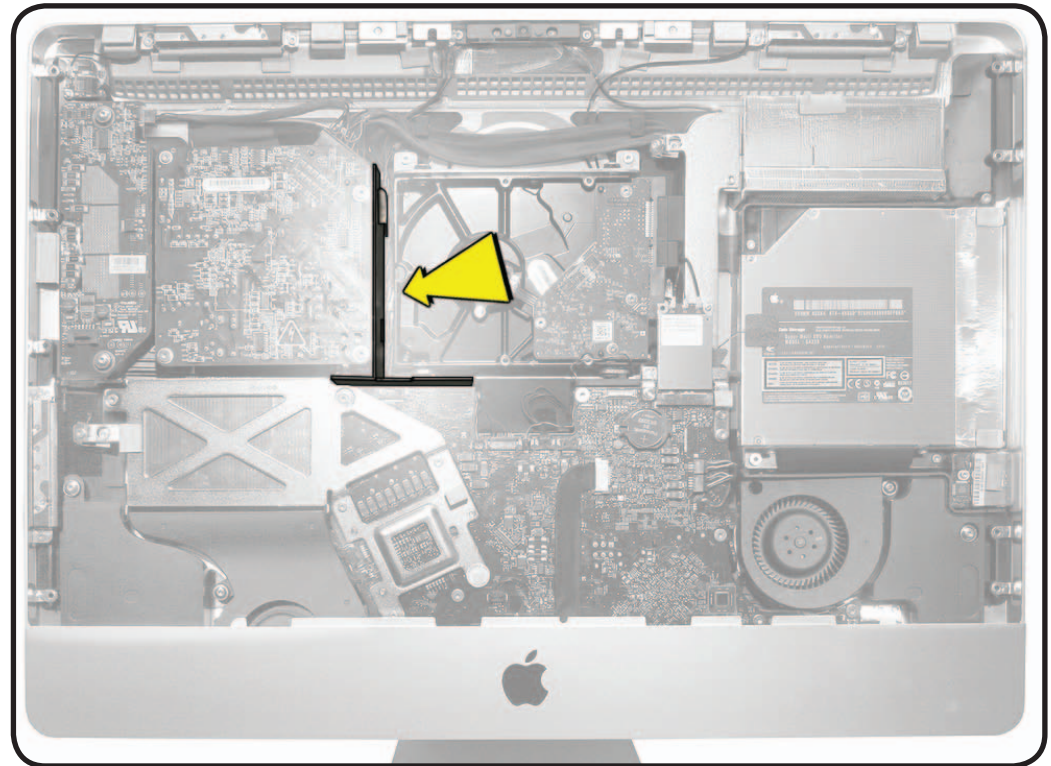

## Tools

- ESD wrist strap





## Removal

- 1 Lift pressure wall off posts in rear housing.

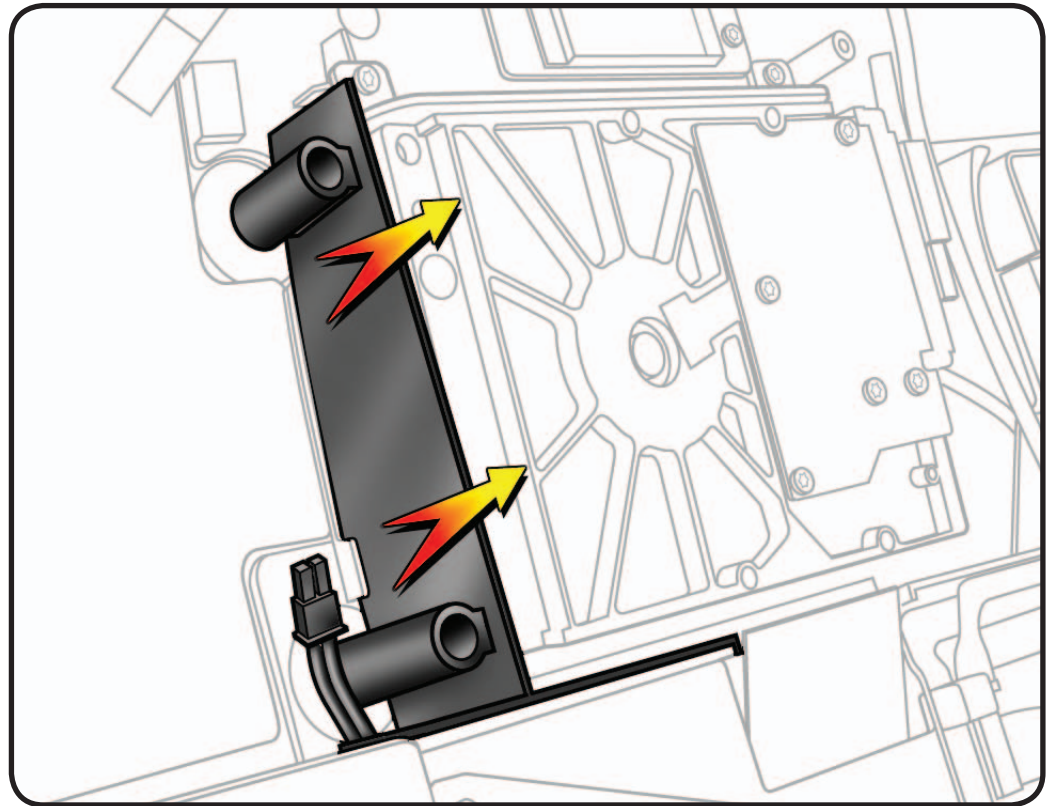



# Bluetooth/Camera/Sensor Cable

## First Steps

Remove:

- Glass Panel
- LCD Panel
- LED Backlight Board
- Power Supply
- Hard Drive (if present in this configuration)
- Power Supply Pressure Wall
- Camera

**Note:** This cable carries both the left skin temp sensor and the ambient light sensor (ALS) signals.

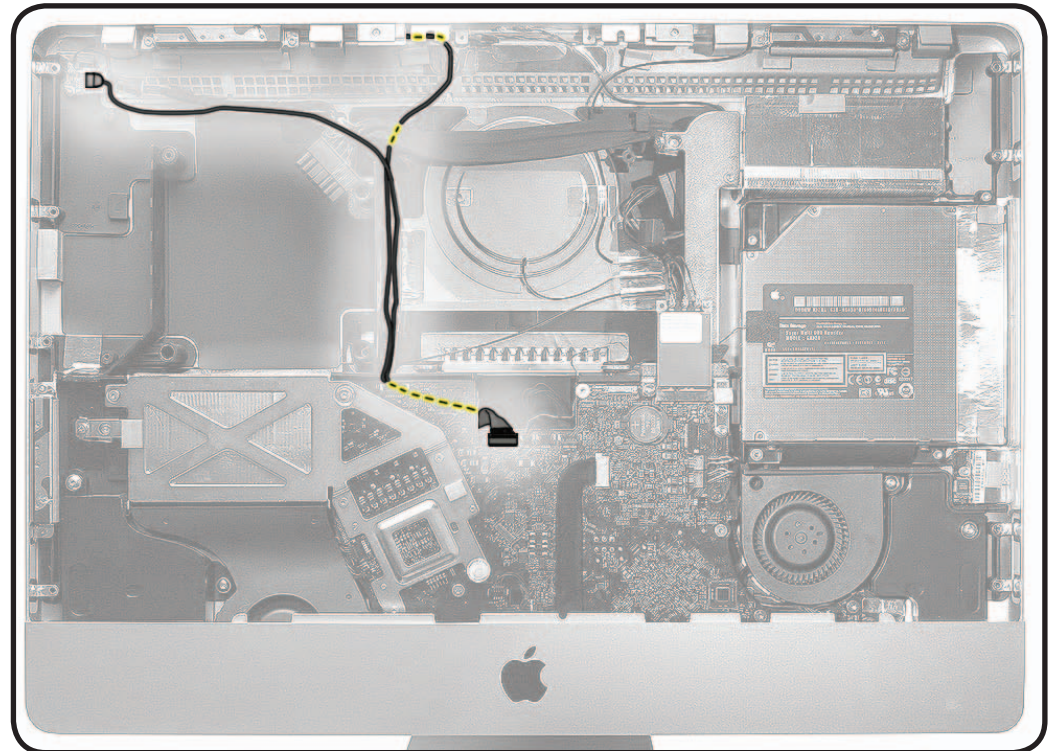

## Tools

- ESD wrist strap





## Removal

- 1 Cable should have been disconnected already from camera.

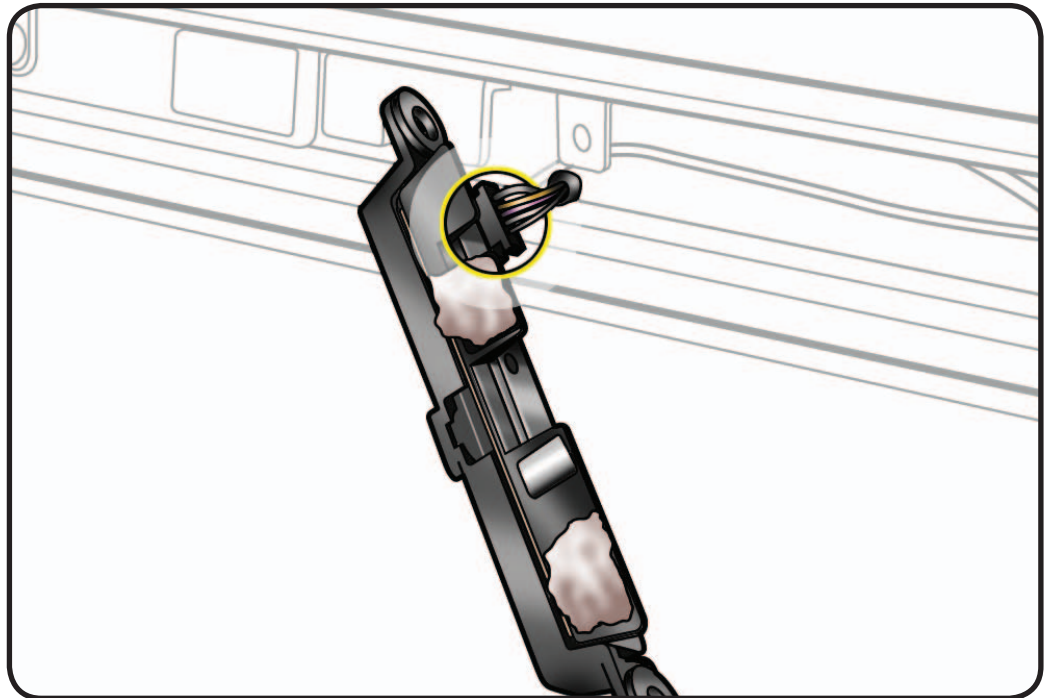

- 2 Disconnect cable from Bluetooth board.

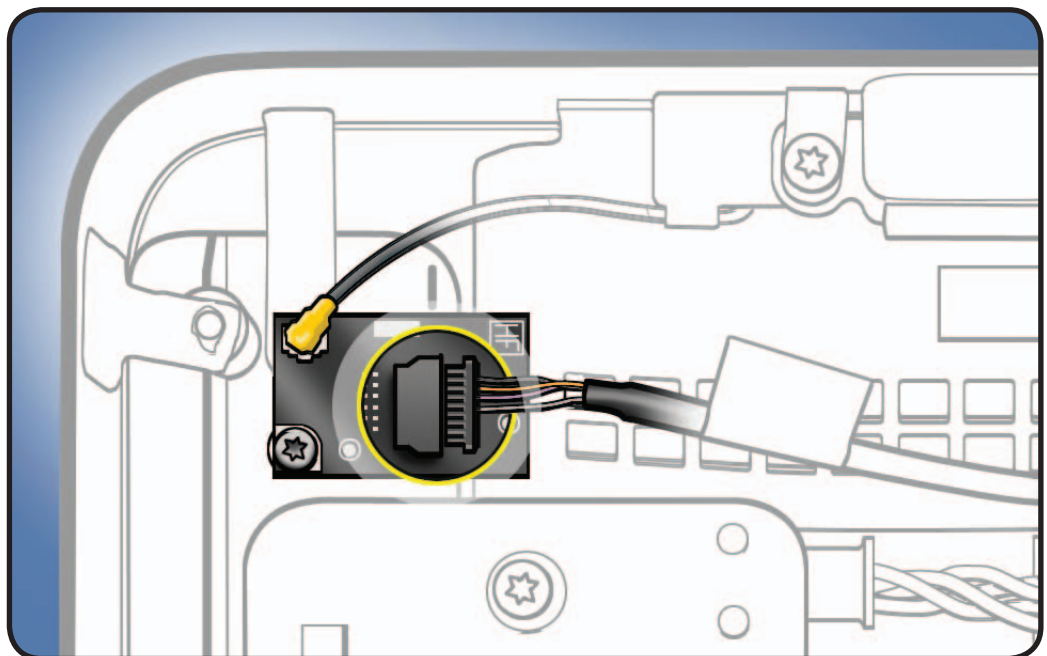



- 3 Remove gasket securing temp sensor to top inside of rear housing, to left of camera, behind a magnet support.

**Reassembly Note:**  
A replacement cable includes a new gasket. Peel & stick to secure temp sensor to top inside of rear housing.

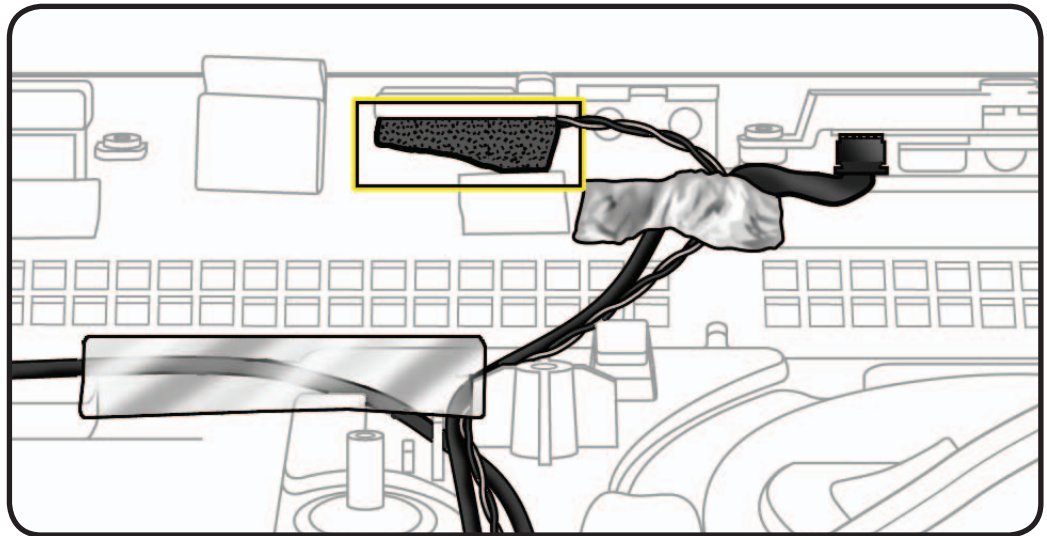

- 4 Disconnect cable (#5) from top center of logic board.

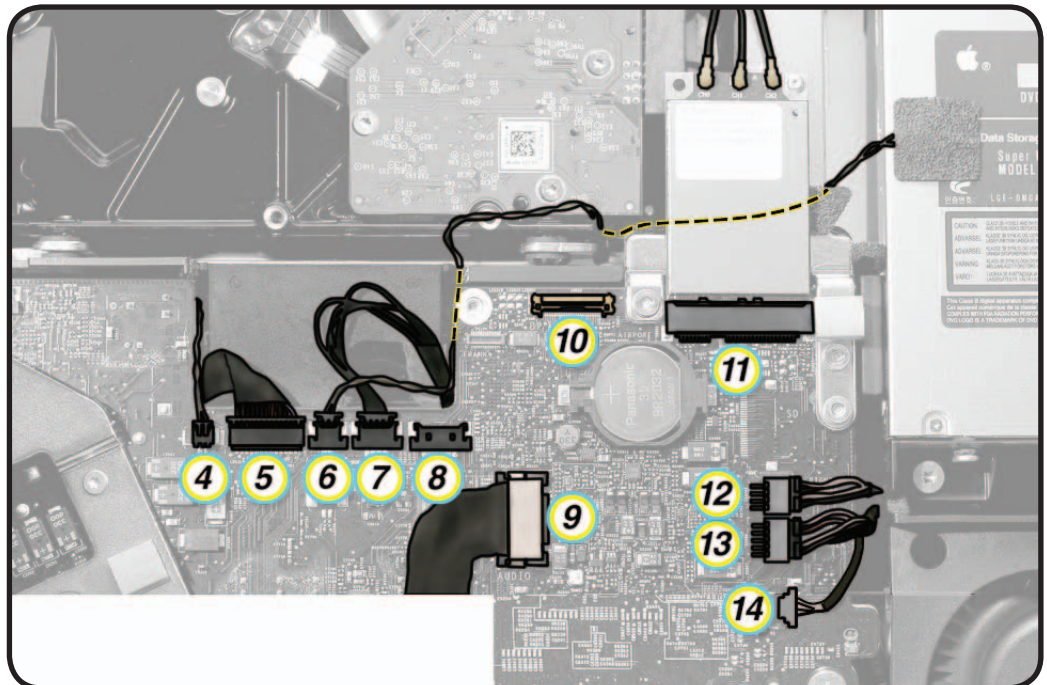



- 5** Observe cable routing and tape placement for reassembly.
- 6** Peel up foil tape and clear tape securing cable to rear housing.

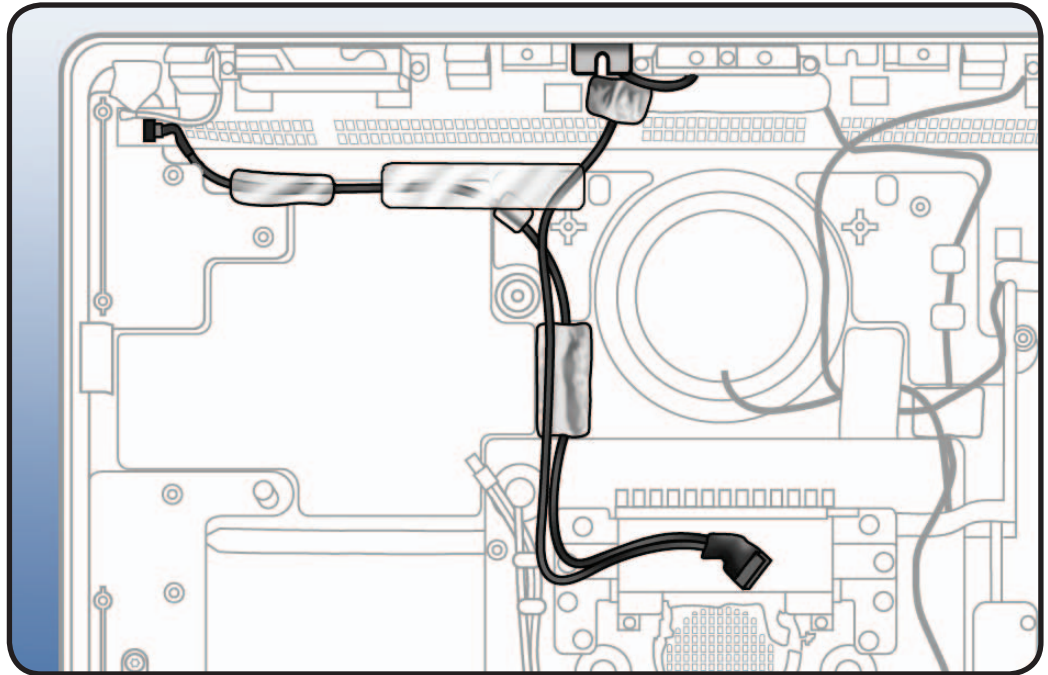



# Skin Temp Sensor Cable

## First Steps

Remove:

- Glass Panel
- LCD Panel
- Power Supply
- Hard Drive (if present in this configuration)
- Power Supply Pressure Wall
- Camera

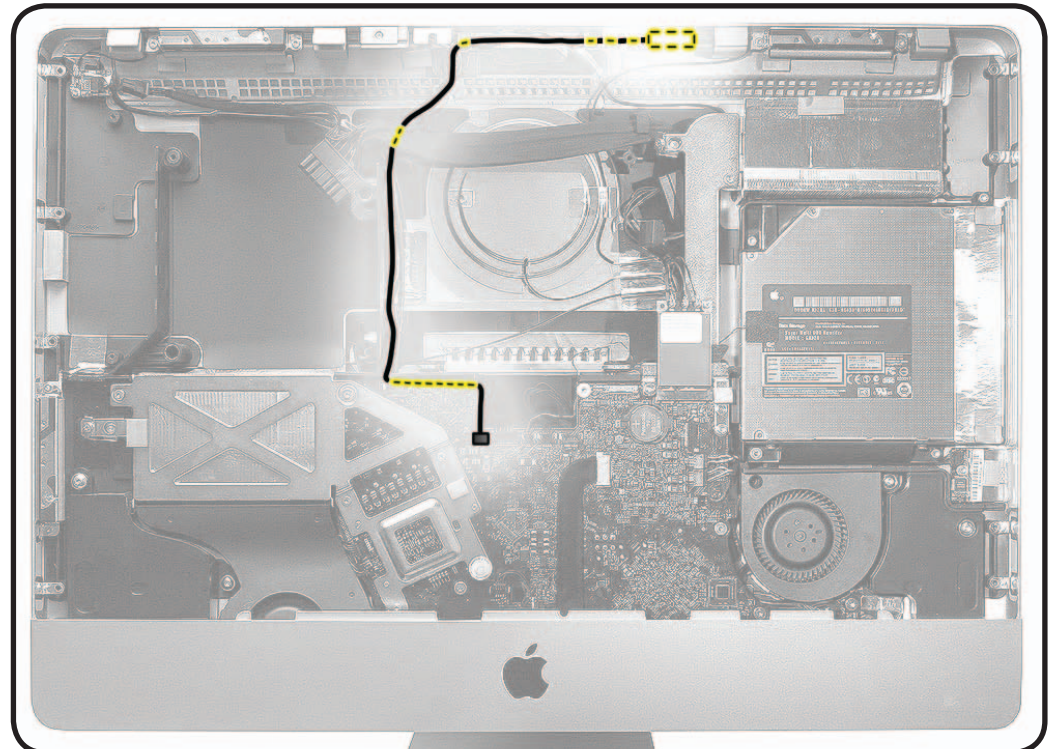

## Tools

- ESD wrist strap





## Removal

- 1 Remove gasket securing temp sensor to top inside of rear housing, to right of camera, behind a magnet support.

### Reassembly Note:

A replacement cable includes a new gasket. Peel & stick to secure temp sensor to top inside of rear housing.

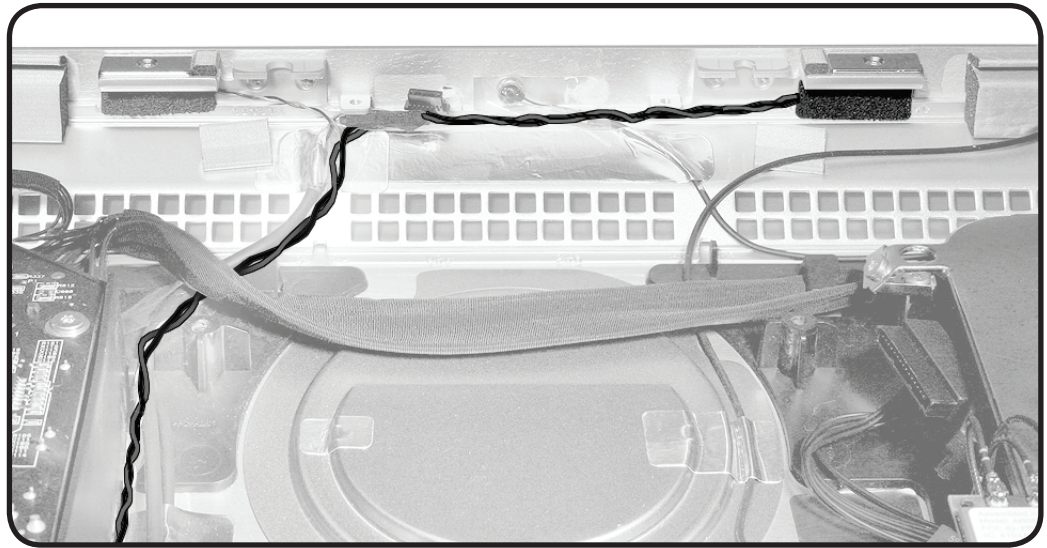

- 2 Disconnect cable (#4) from top center of logic board.
- 3 Observe cable routing and tape placement for reassembly. See image on previous page.

This cable follows a similar path as the Bluetooth/camera/sensor cable along the power supply pressure wall to the logic board.

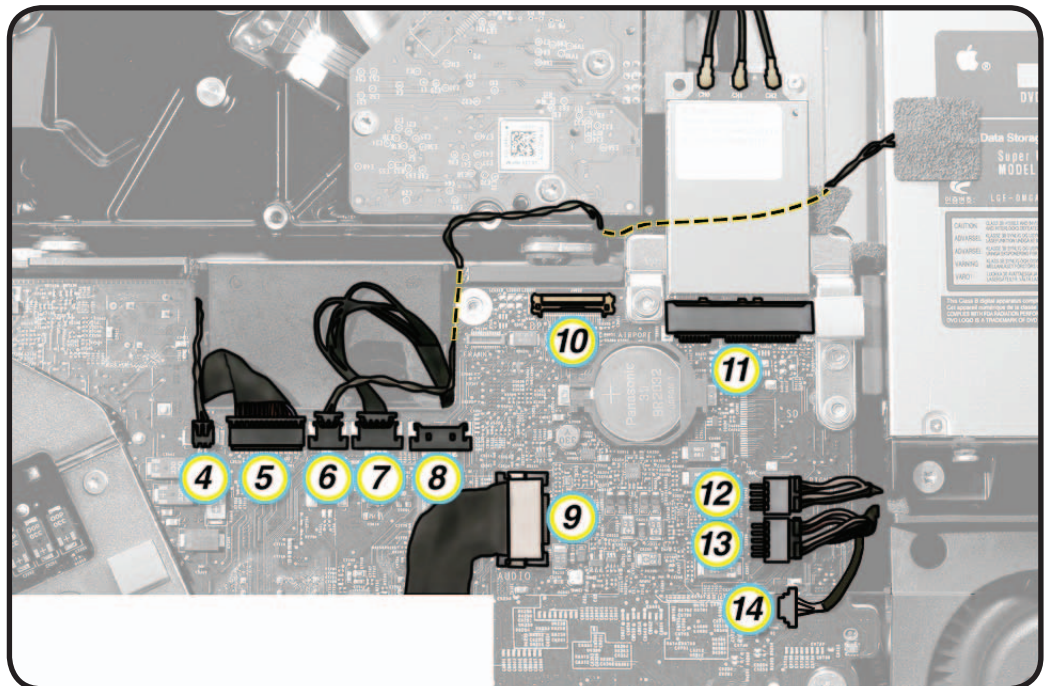



# AirPort Antenna, Top Right

## First Steps

Remove:

- Glass Panel
- LCD Panel
- Hard Drive (if present in this configuration)

**Note:** There is another removable AirPort antenna along the left side of the rear housing.

There is also a third AirPort antenna built-in to rear housing behind Apple logo on back of iMac, however, it is not removable and can only be repaired via rear housing replacement.

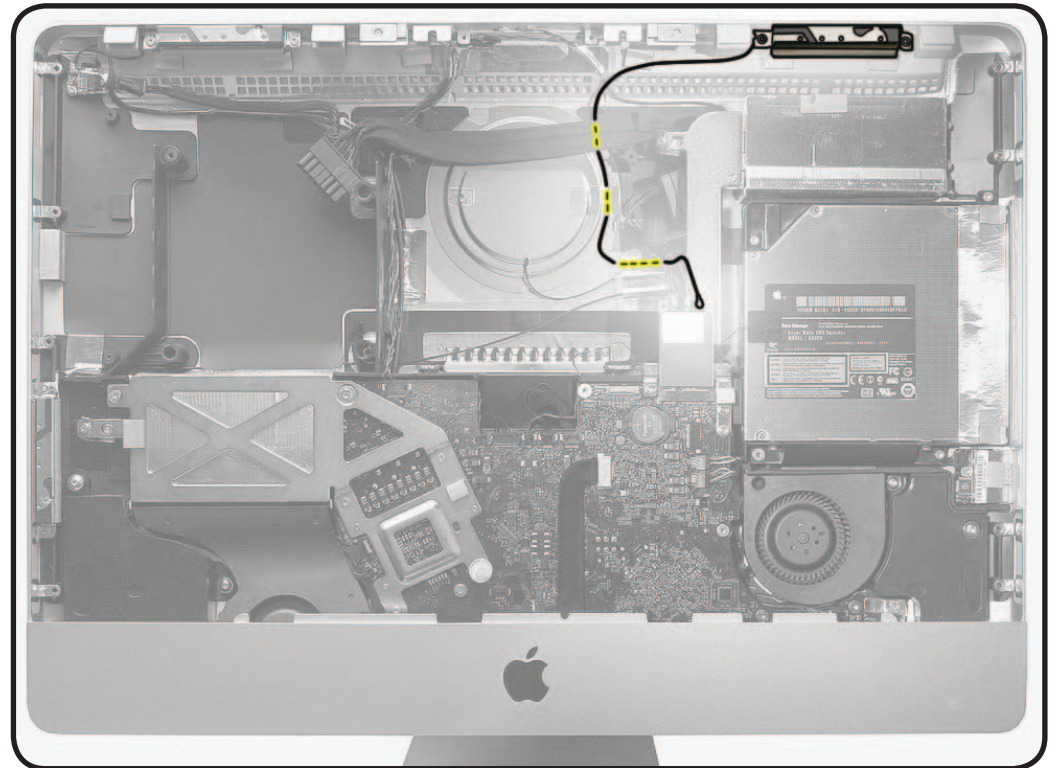

## Tools

- ESD wrist strap
- Torx T8 screwdriver

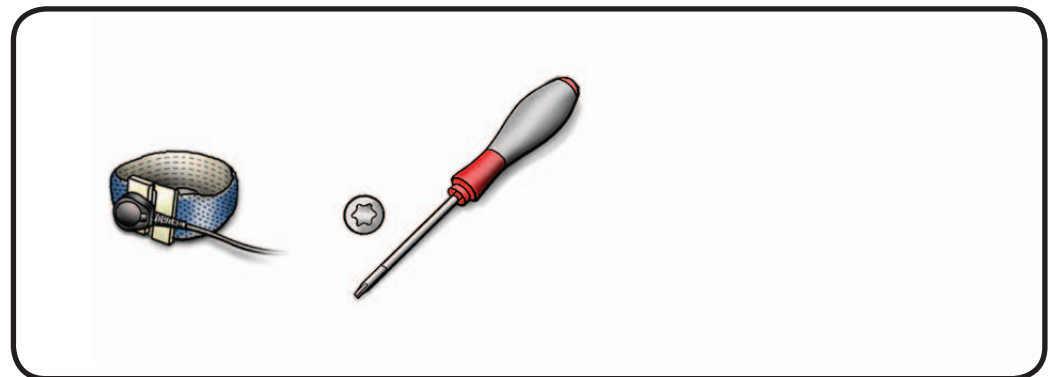



## Removal

- 1 Disconnect antenna cable from CH2 connector on AirPort card.

**Caution:** Be careful not to damage antenna connectors.

- 2 Peel up 2 pieces of foil tape securing antenna cable to rear housing.

- 3 Remove T8 screws: (2) 922-4723

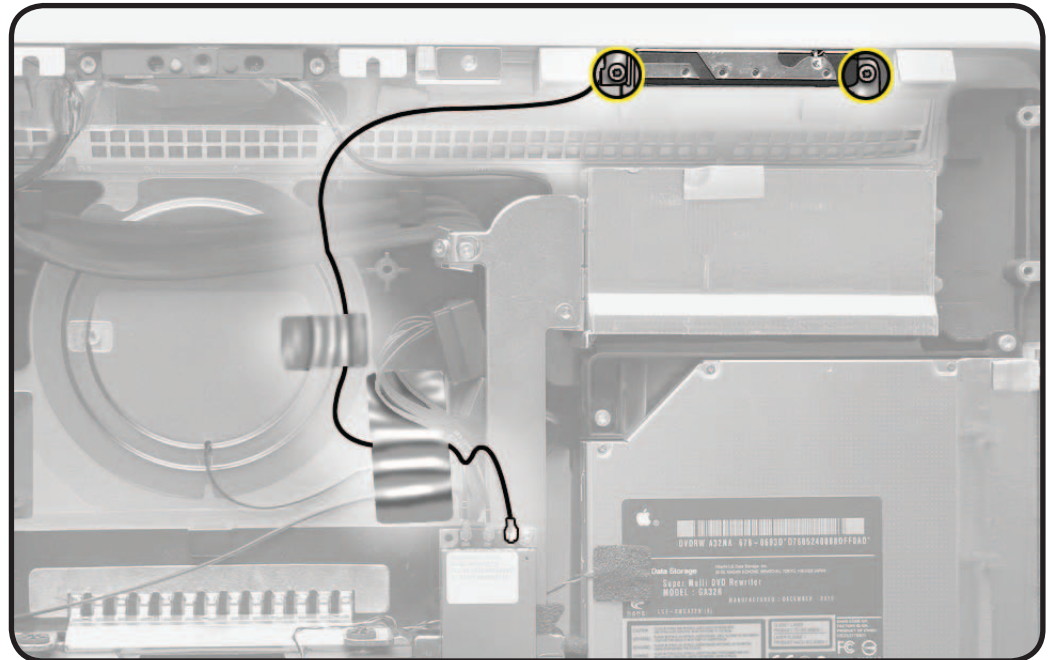

**Reassembly Note:** The three black AirPort antenna cables are marked with 0, 1, or 2 light stripes. The cable lengths are designed to attach to specific connectors.

- Cable with **2 stripes** attaches to **CH0** connector.
- Cable with 1 stripe attaches to CH1 connector.
- Cable with **0 stripes** attaches to **CH2** connector.

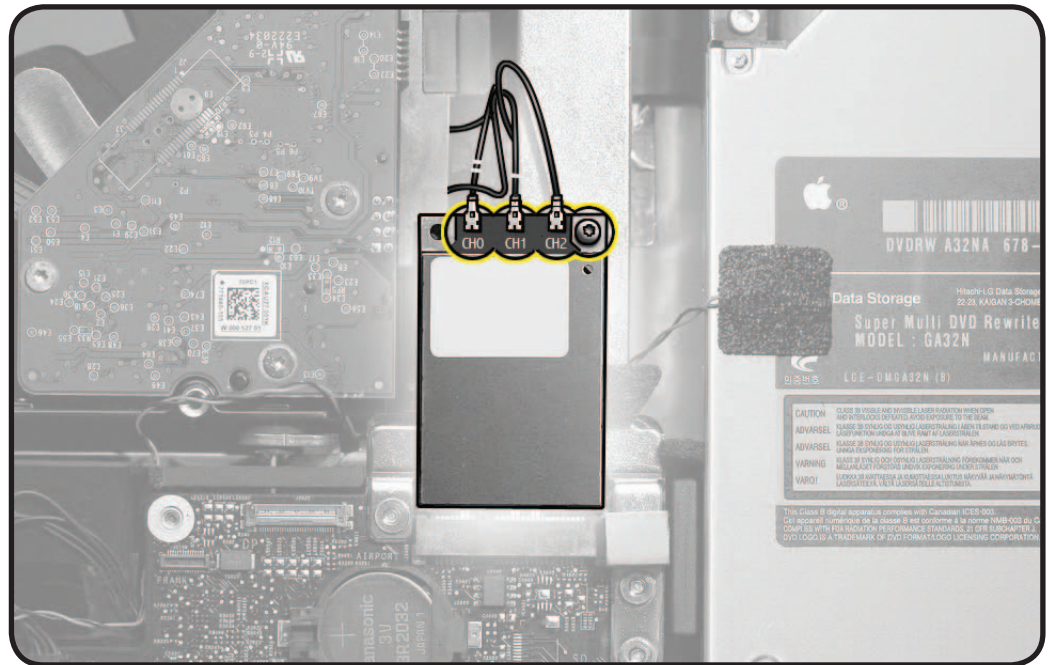



# AirPort Antenna, Left Side

## First Steps

Remove:

- Glass Panel
- LCD Panel
- LED Backlight Board
- Power Supply
- Backlight Pressure Wall
- Hard Drive (if present in this configuration)
- Power Supply Pressure Wall

**Note:** There is another removable AirPort antenna along top right of the rear housing.

There is also a third AirPort antenna built-in to rear housing behind Apple logo on back of iMac, however, it is not removable and can only be repaired via rear housing replacement.

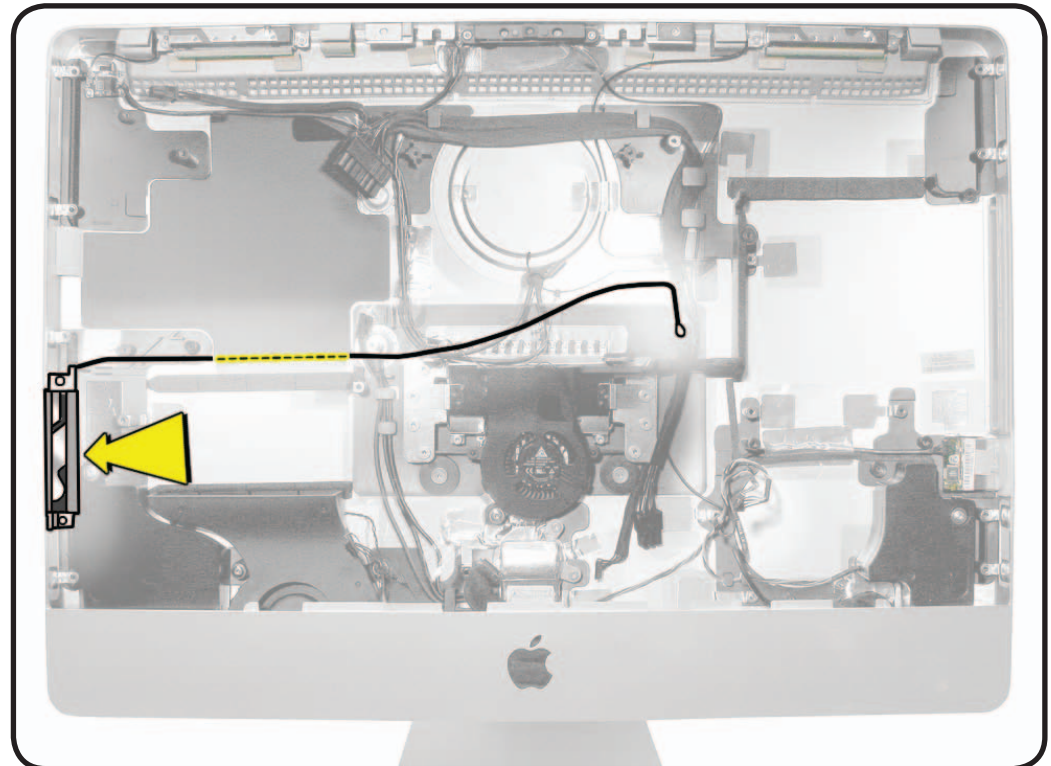

## Tools

- ESD wrist strap
- Torx T8 screwdriver

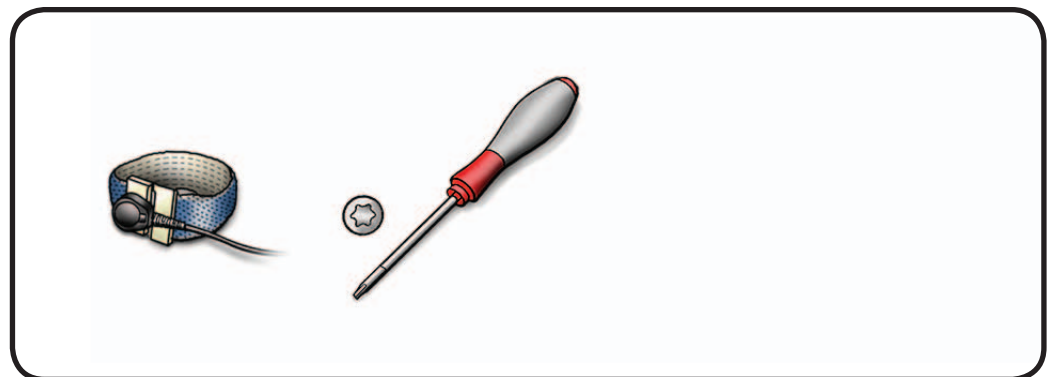



## Removal

- 1 Disconnect antenna cable from AirPort card.

**Caution:** Be careful not to damage antenna connectors.

- 2 Peel up 2 pieces of foil tape securing antenna cable to rear housing.

- 3 Remove T8 screws: (2) 922-9880

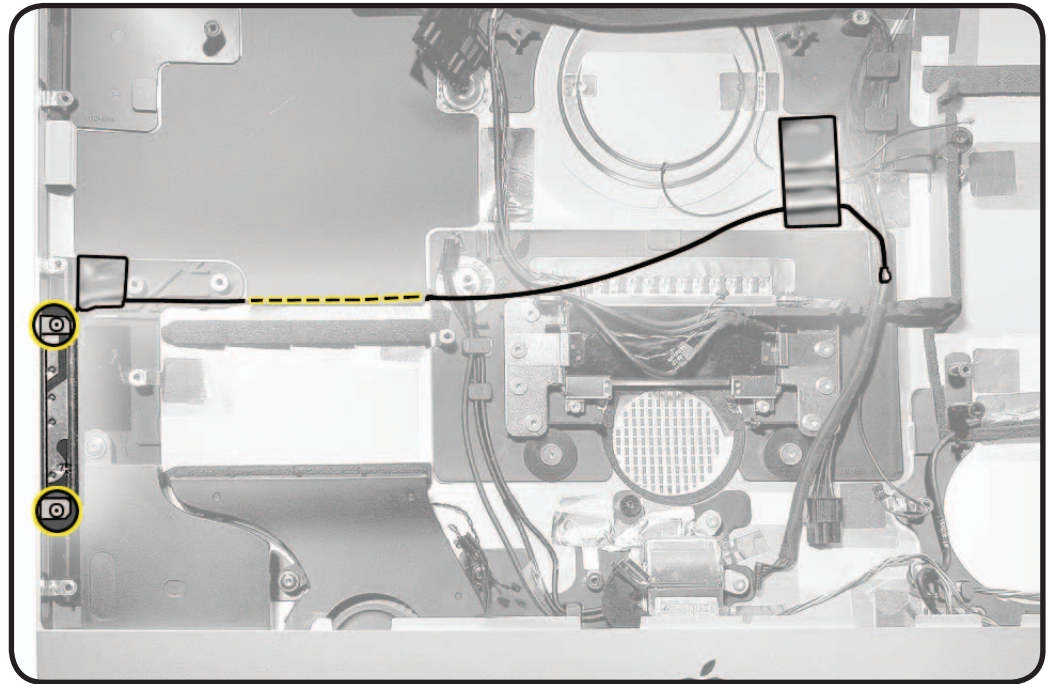

**Reassembly Note:** The three black AirPort antenna cables are marked with 0, 1, or 2 light stripes. The cable lengths are designed to attach to specific connectors.

- Cable with **2 stripes** attaches to **CH0** connector.
- Cable with 1 stripe attaches to CH1 connector.
- Cable with **0 stripes** attaches to **CH2** connector.

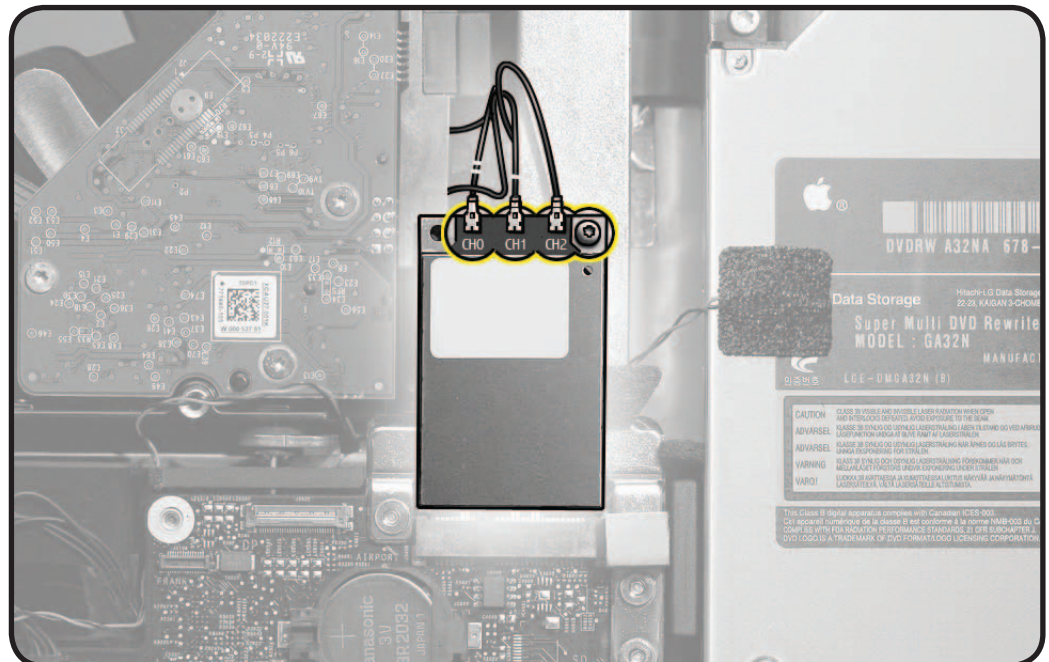



# Optical Disc Drive (ODD)

## First Steps

Remove:

- Glass Panel
- LCD Panel
- Hard Drive (if present in this configuration)

**Important:** When servicing optical drive, handle it by edges only. Pressing elsewhere on drive could damage internal mechanism.

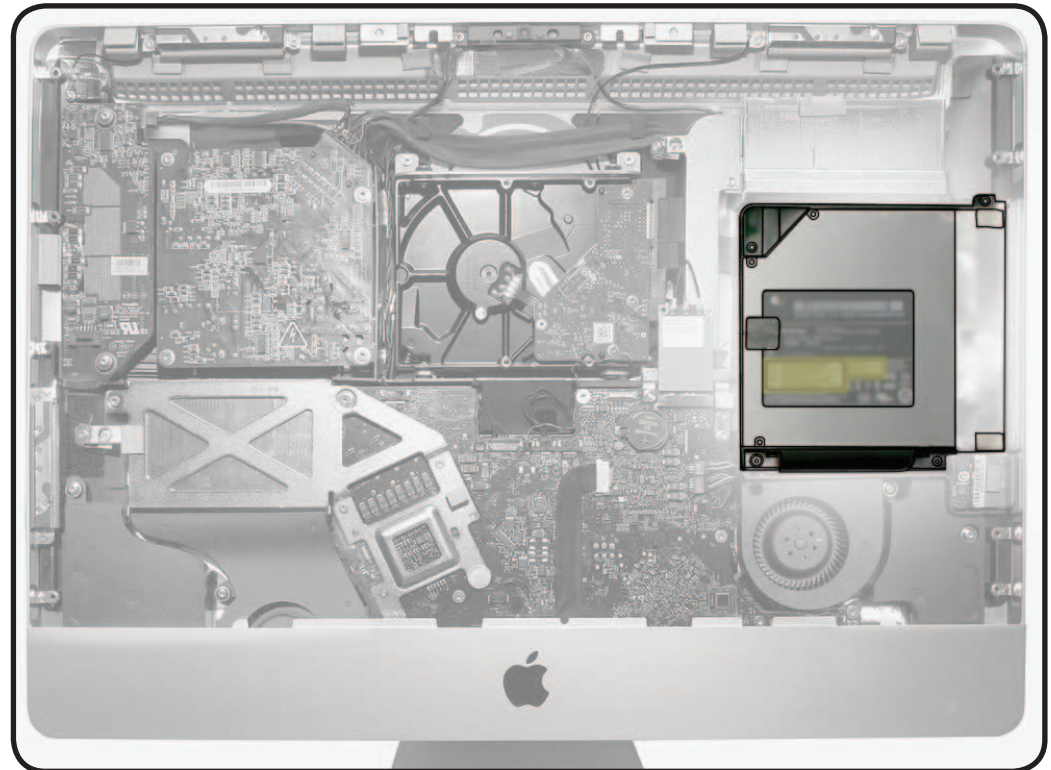

## Tools

- ESD wrist strap
- Torx T10 screwdriver
- Black stick

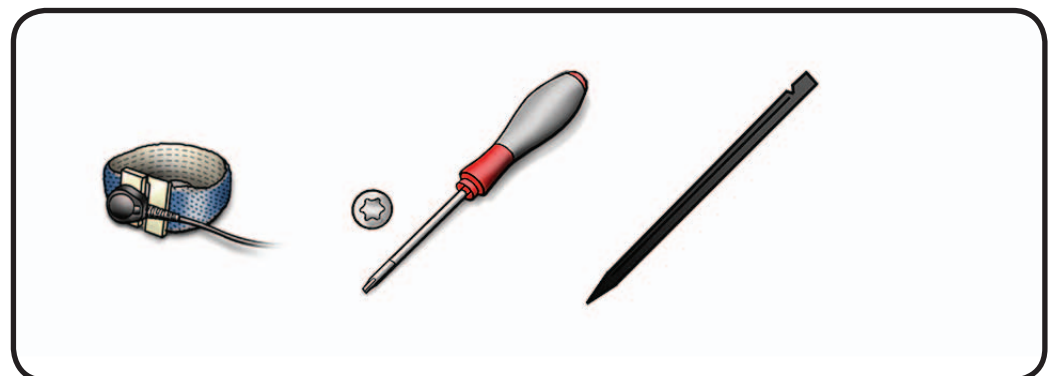



## Removal

- 1 Remove T10 screws:  
(3) 922-6850



- (1) 922-9885, bottom left, has a larger head

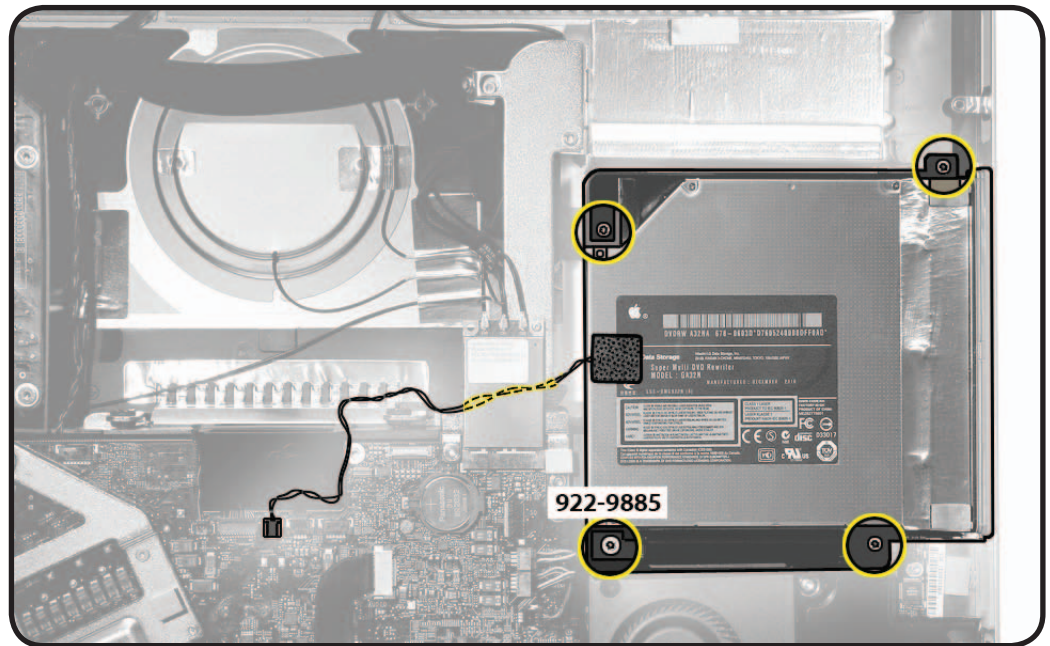

- 2 Disconnect optical drive sensor cable (#6) from top center of logic board.

**Note:** No need to remove sensor cable from optical drive. A replacement drive will include a new sensor cable.

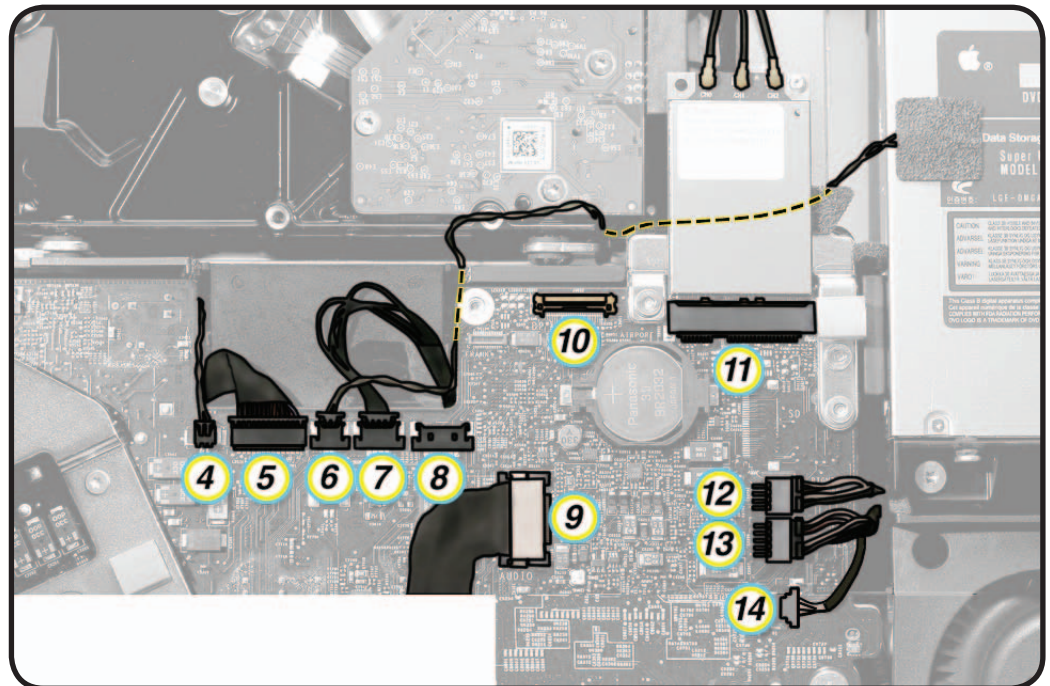



- 3 Lift optical drive slightly and wiggle data cable away from optical drive. A black stick may be helpful.
- 4 Pull optical drive away from slot opening in rear housing.

**Reassembly Note:**  
Reinstall drive and insert optical media to check that drive is correctly aligned with rear housing.

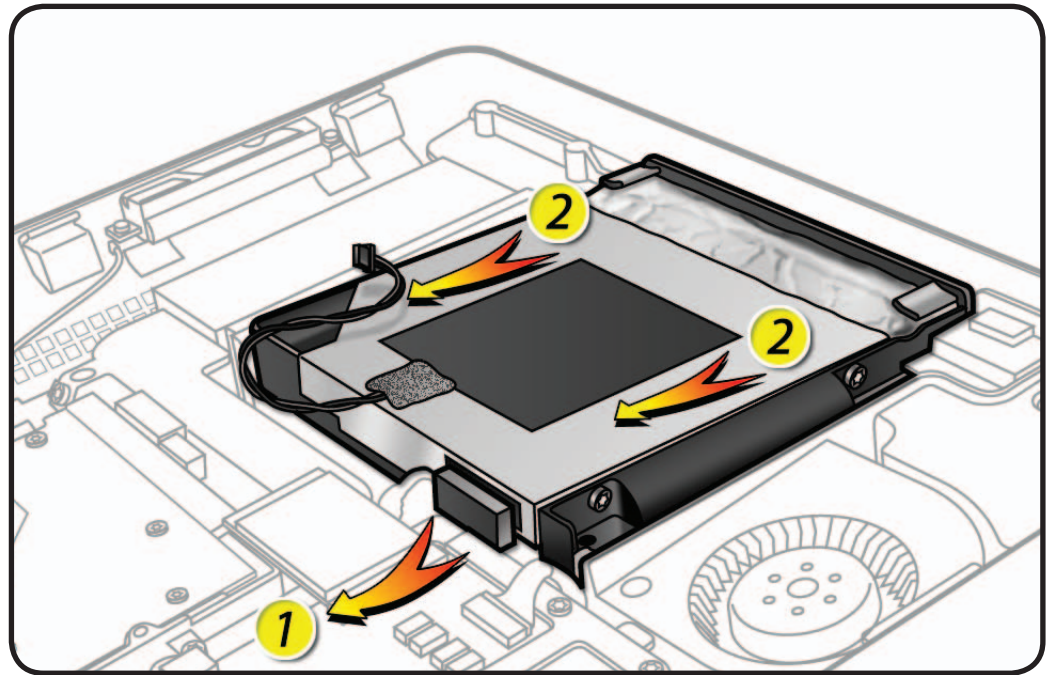



# Optical Drive Sensor Cable

## First Steps

Remove:

- Glass Panel
- LCD Panel
- Hard Drive (if present in this configuration)

**Note:** A new optical drive includes a new sensor cable. This procedure is only used when replacing just the sensor cable.

**Replacement Note:**

A new sensor cable includes a new foam gasket.

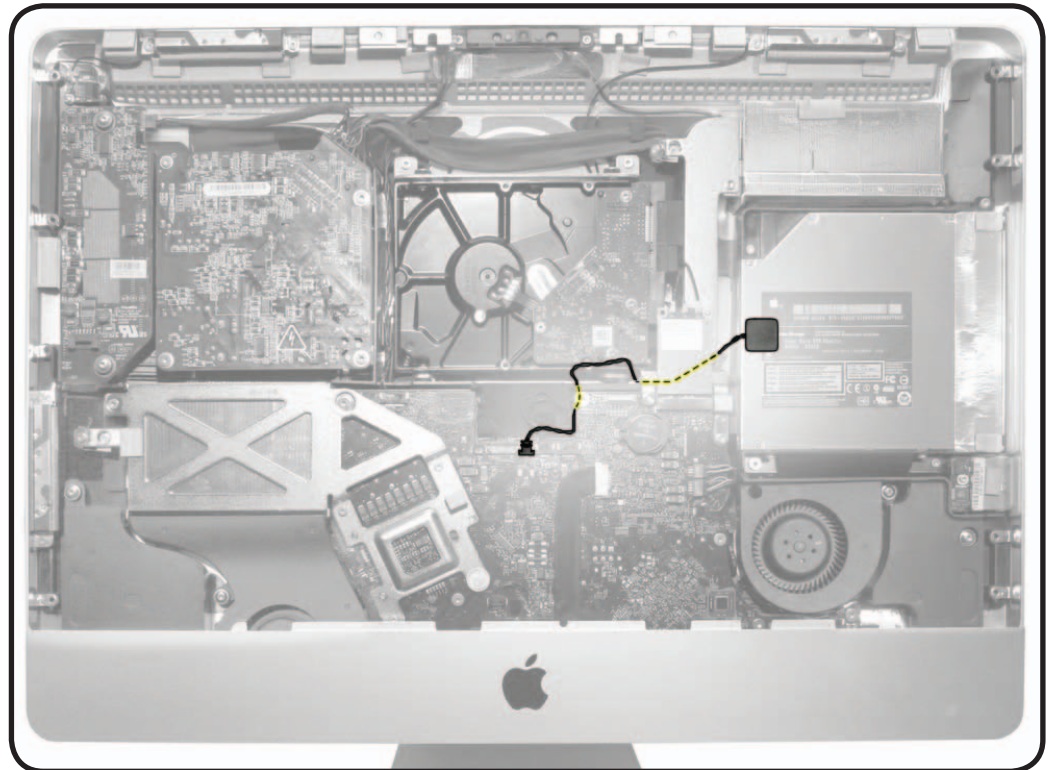

## Tools

- ESD wrist strap





## Removal

- 1 Disconnect cable (#6) from top center of logic board.

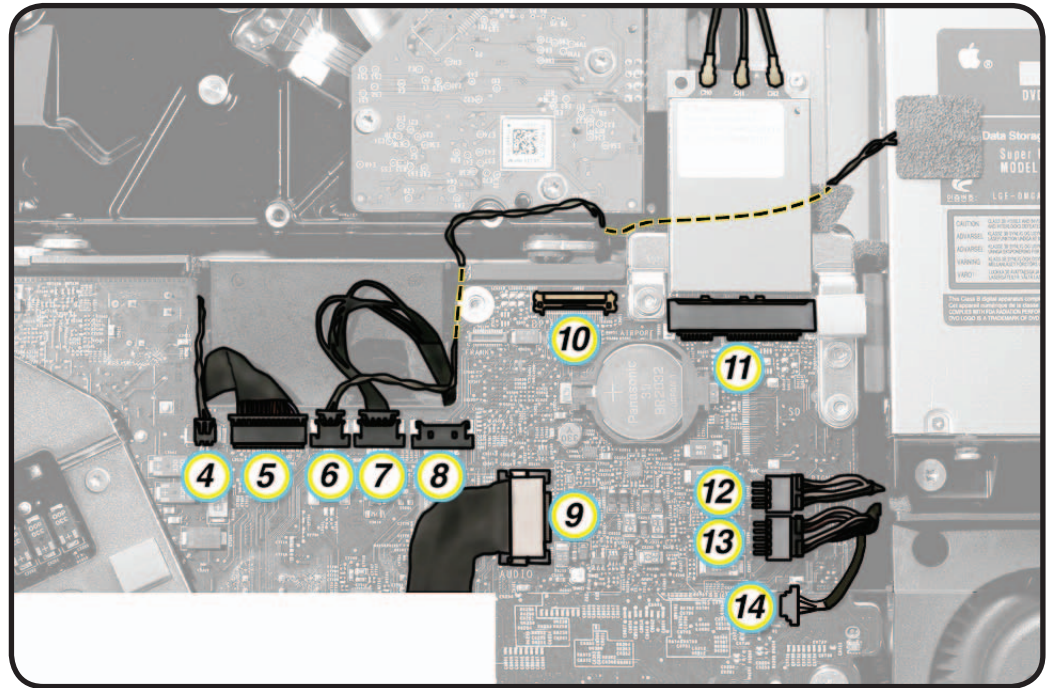

- 2 On optical drive, peel back foam gasket and remove sensor.

### Replacement Note:

Peel and stick new sensor and fully cover with gasket to isolate sensor from internal air temperature.

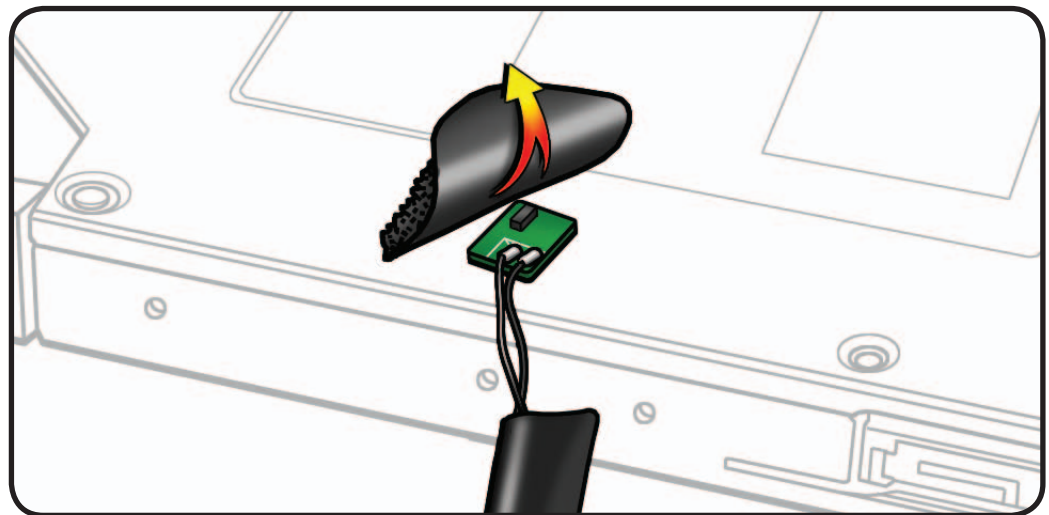



# Optical Drive Fan

## First Steps

Remove:

- Glass Panel
- LCD Panel
- Optical Drive

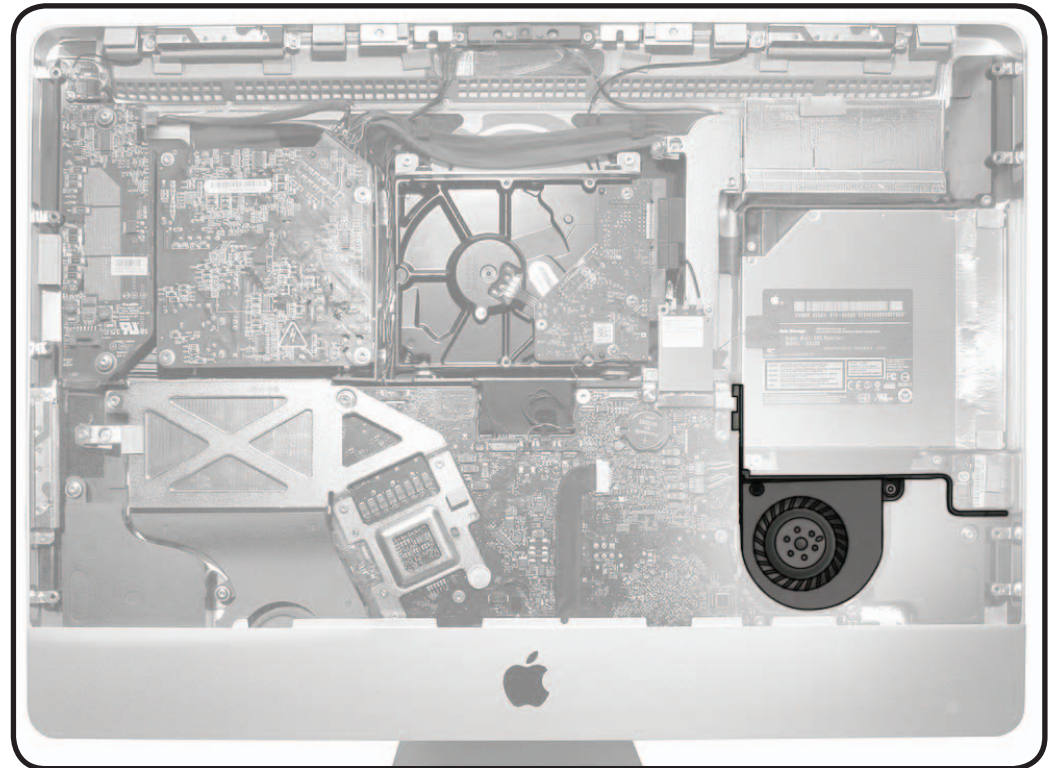

## Tools

- ESD wrist strap
- Torx T10 screwdriver

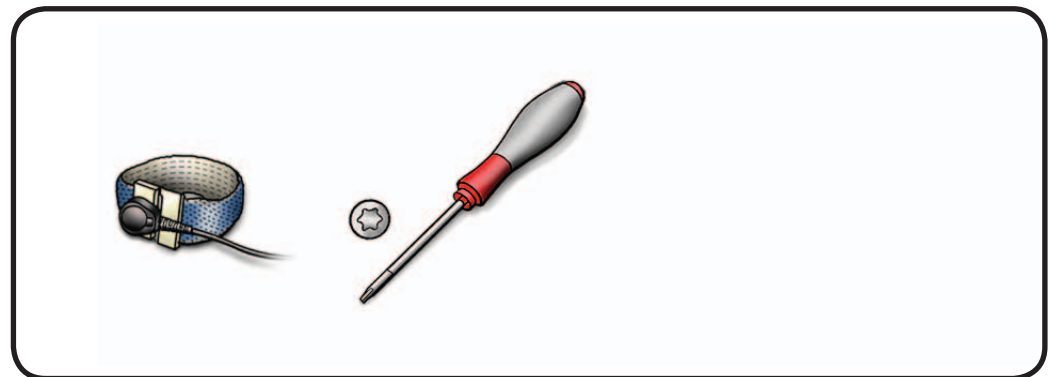



## Removal

- 1 Remove T10 screw:  
(1) 922-9236



- 2 Lift fan up off guide posts in rear housing and disconnect cable from logic board.

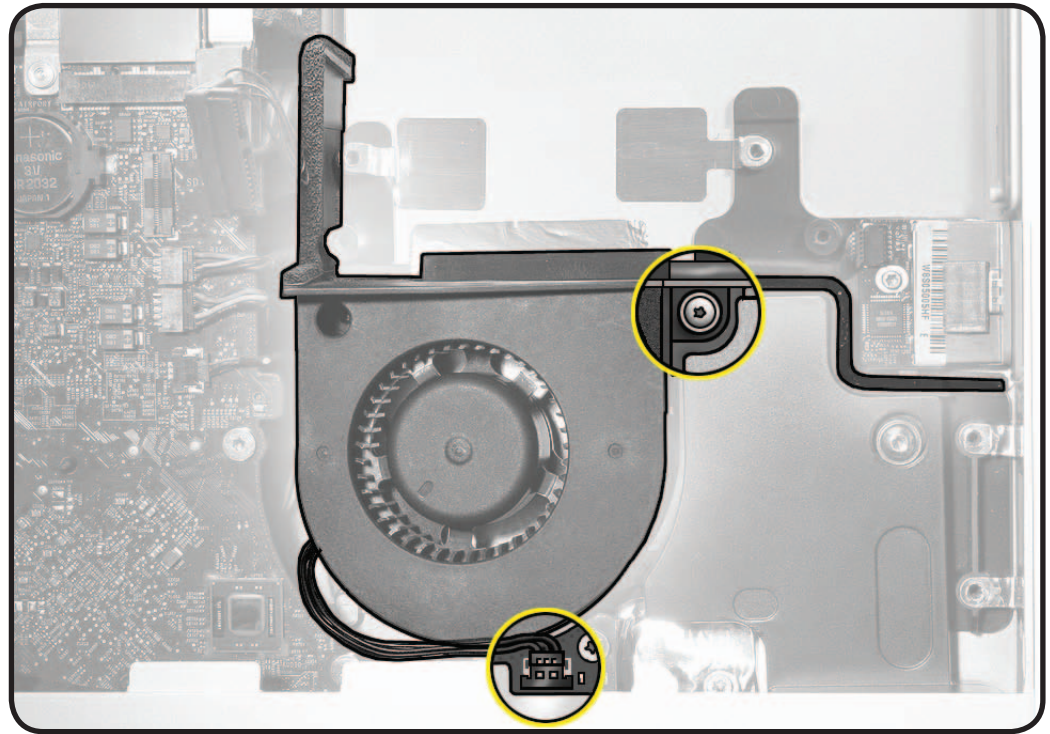



# SD Card Reader

## First Steps

Remove:

- Glass Panel
- LCD Panel

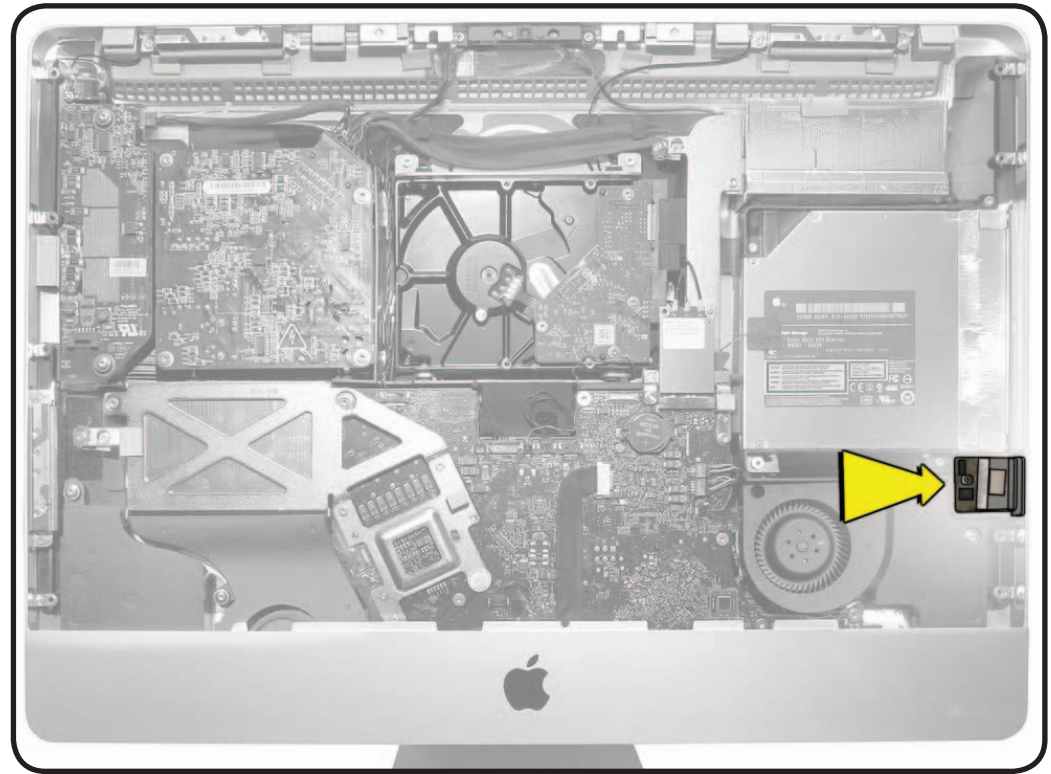

## Tools

- ESD wrist strap
- Torx T8 screwdriver
- Black stick

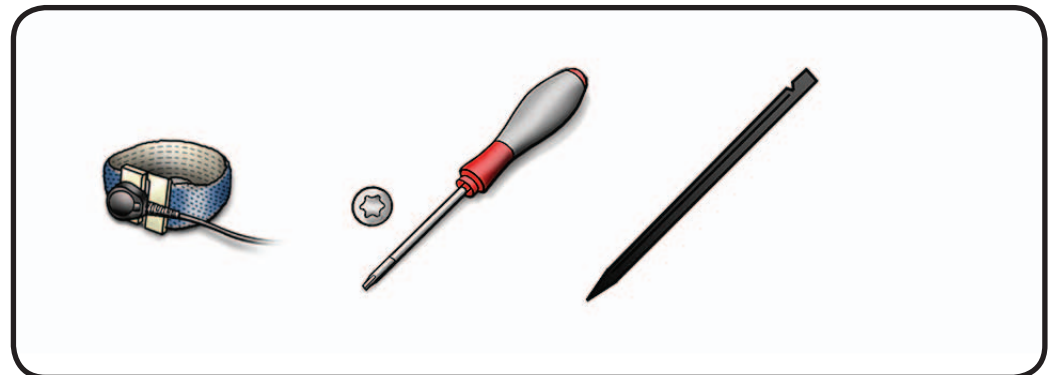



## Removal

- 1 Remove T8 screw:  
(1) 922-9241

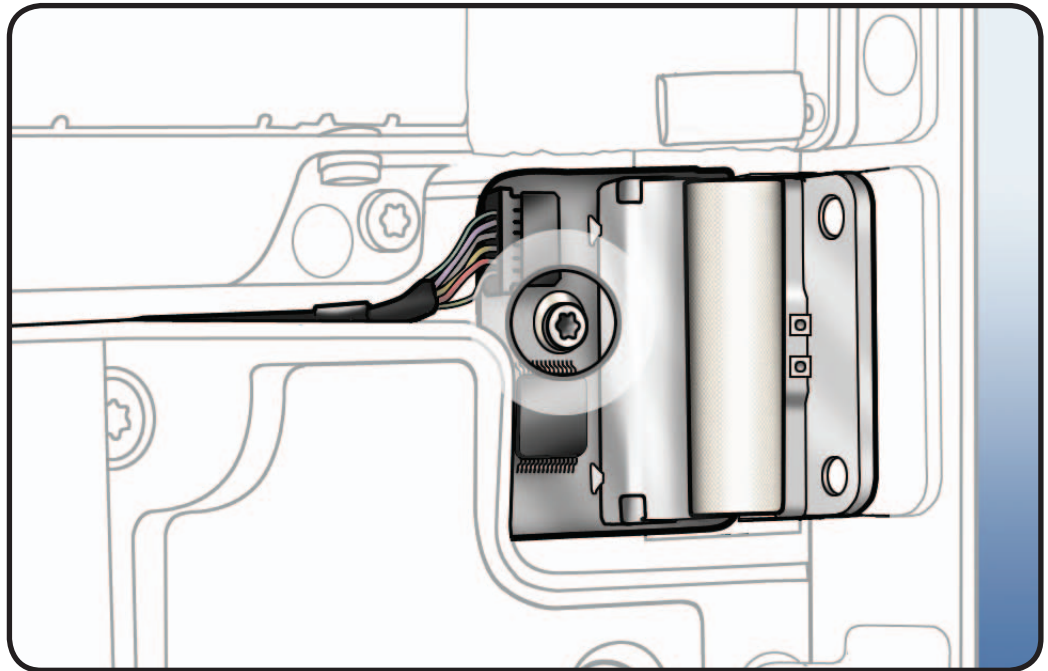

- 2 Using a black stick, gently pry SD card reader up and out of rear housing.
- 3 Disconnect cable.

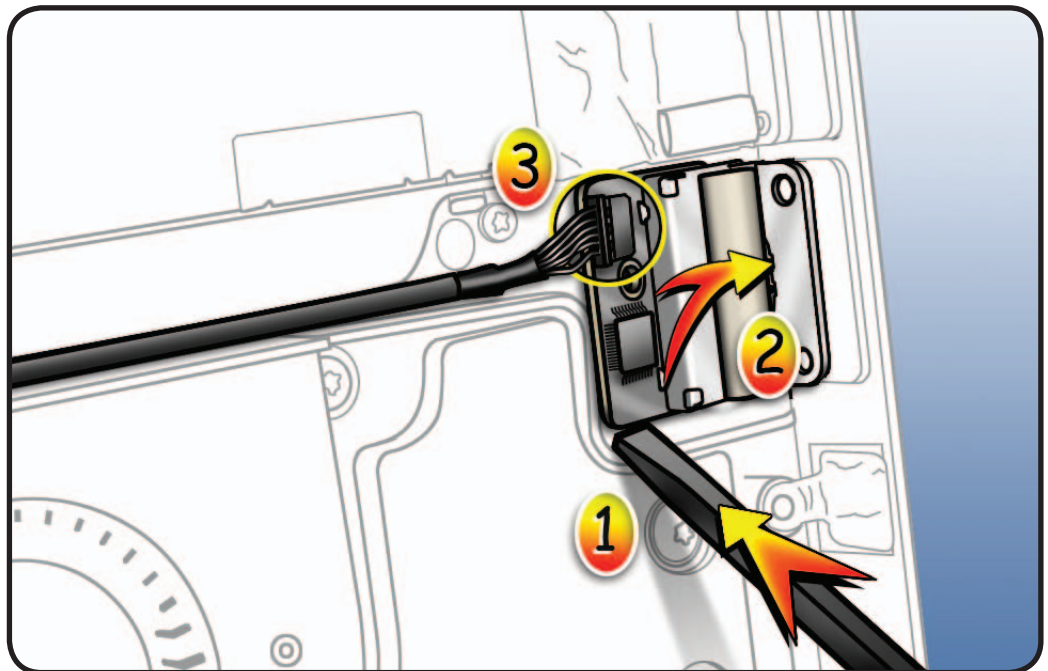



# SD Card Reader Cable

## First Steps

Remove:

- Glass Panel
- LCD Panel
- Optical Drive
- Optical Drive Fan

**Note:** A new rear housing includes a new SD card reader cable.

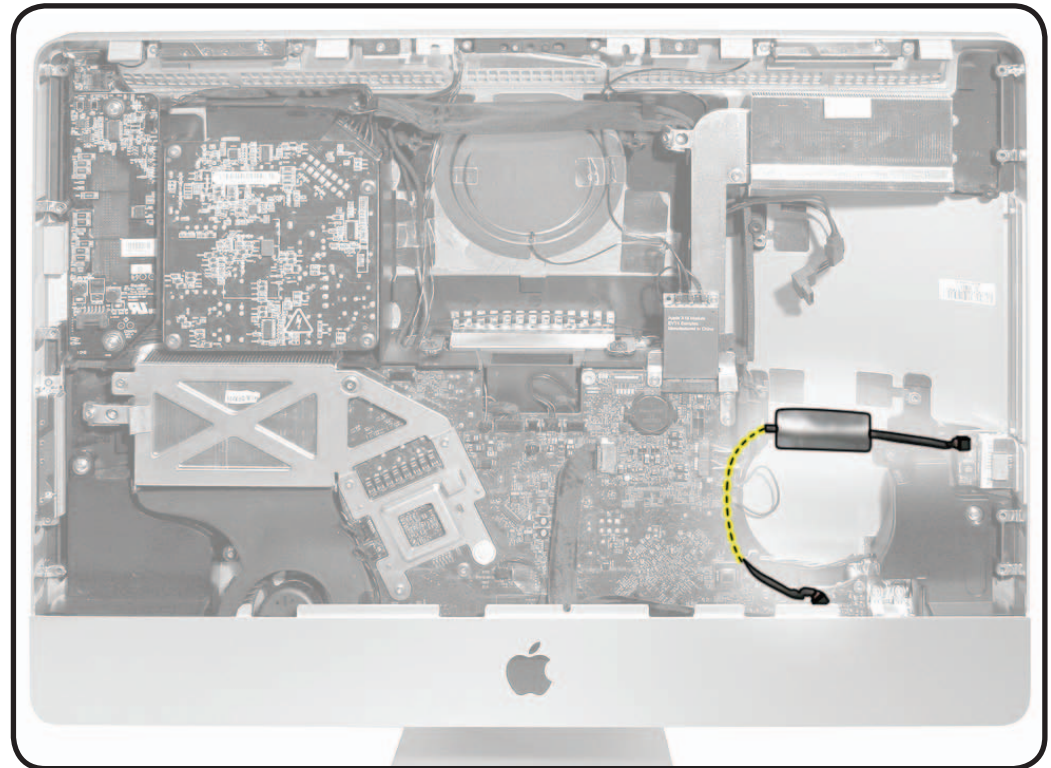

## Tools

- ESD wrist strap





## Removal

- 1 Disconnect cable from SD card reader and logic board.
- 2 Peel up foil holding cable to rear housing.

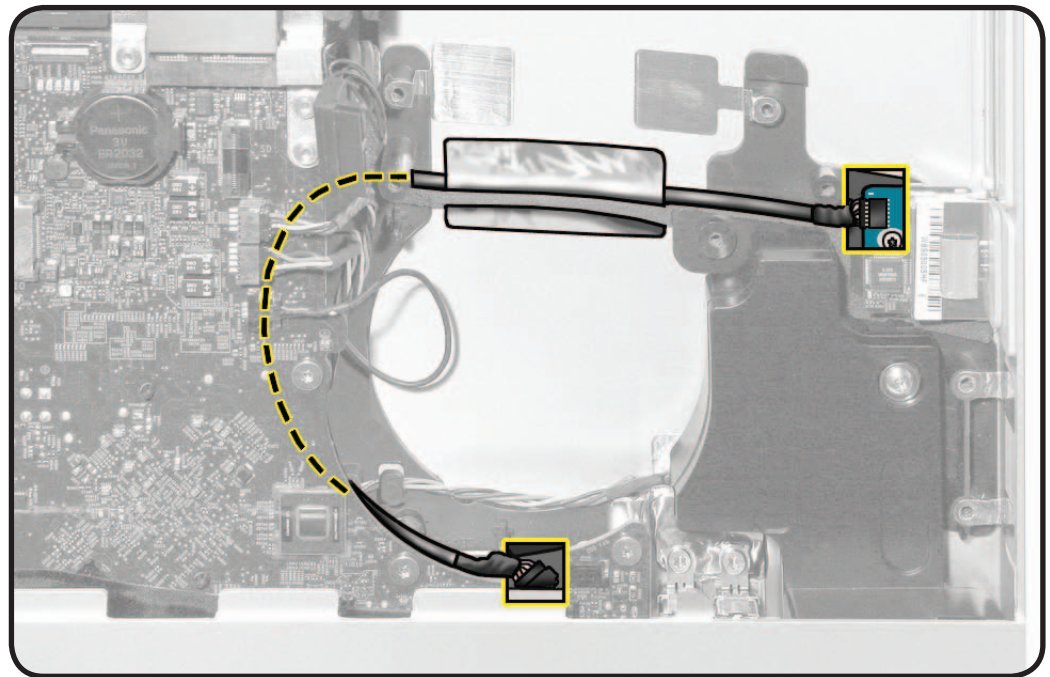



# Audio Ports & Cable

## First Steps

Remove:

- Glass Panel
- LCD Panel

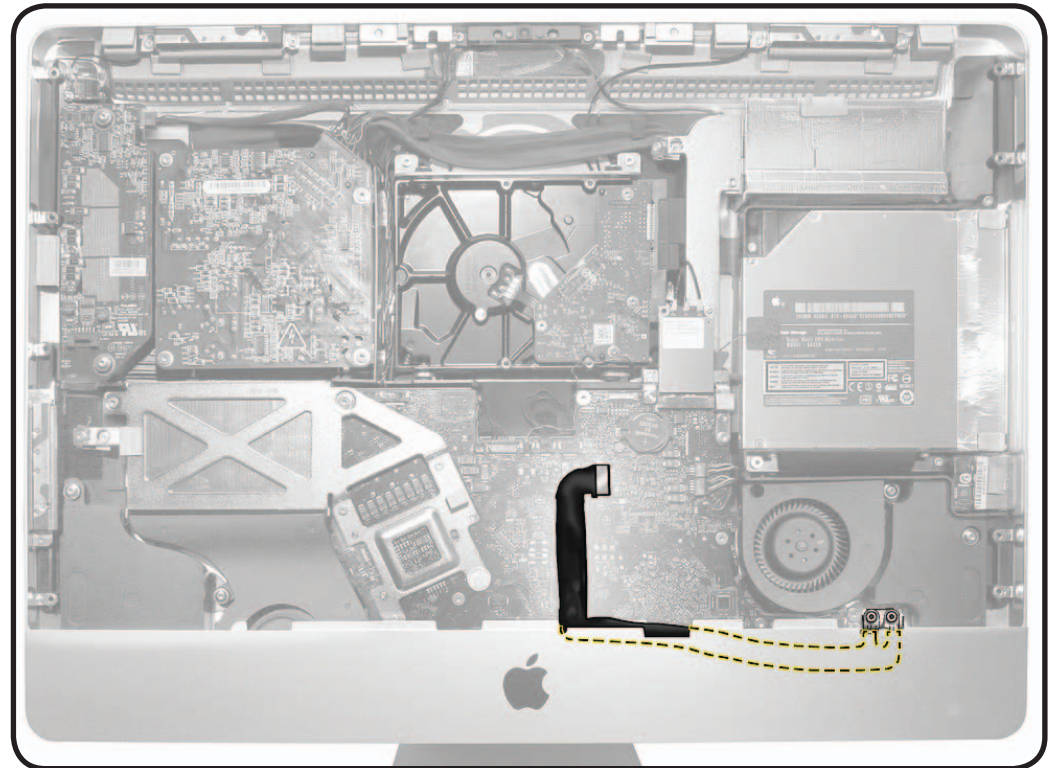

## Tools

- ESD wrist strap
- Torx T10 screwdriver
- Earbuds for reassembly

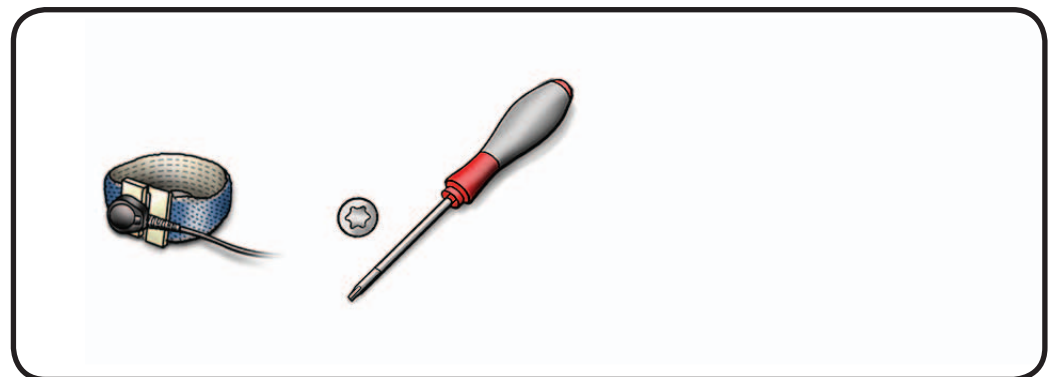



## Removal

- 1 Disconnect cable from logic board.
- 2 Remove T10 screws:  
(2) 922-9245

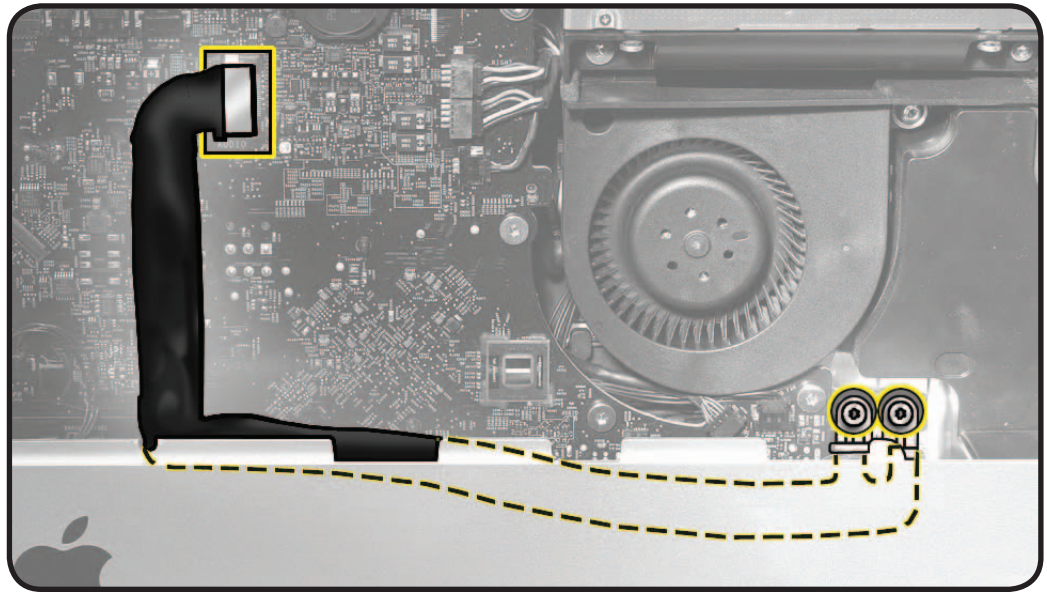

### Reassembly Note:

A black stick can be helpful for guiding and aligning audio ports with rear housing.

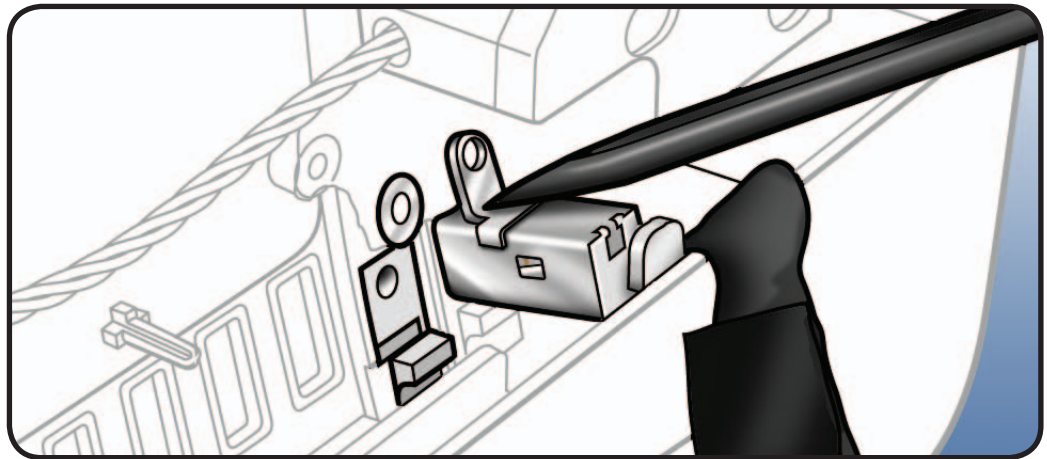

### Reassembly Note:

Plugging in earbuds or headphones can also help keep audio ports aligned while tightening screws.

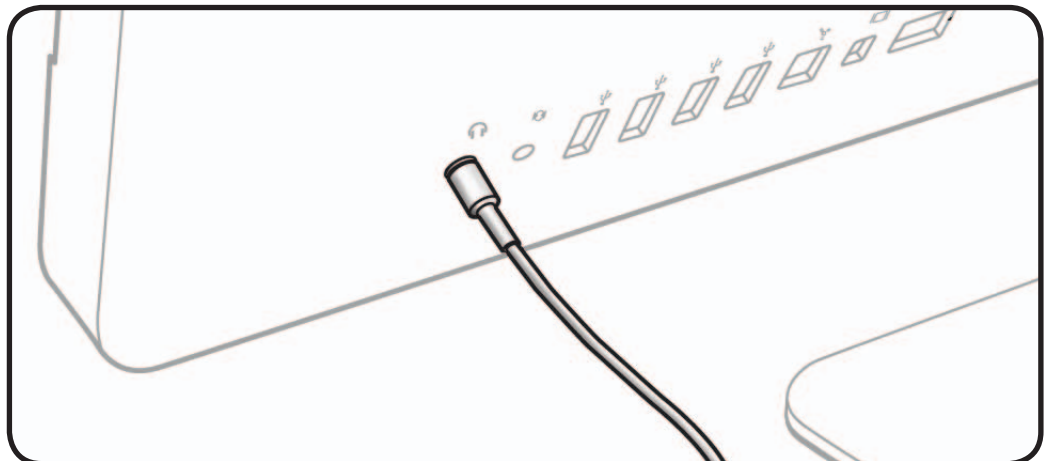



# IR Board & Cable

## First Steps

Remove:

- Glass Panel
- LCD Panel

**Note:** A new IR board includes a new cable. The cable is not available as a separate part.

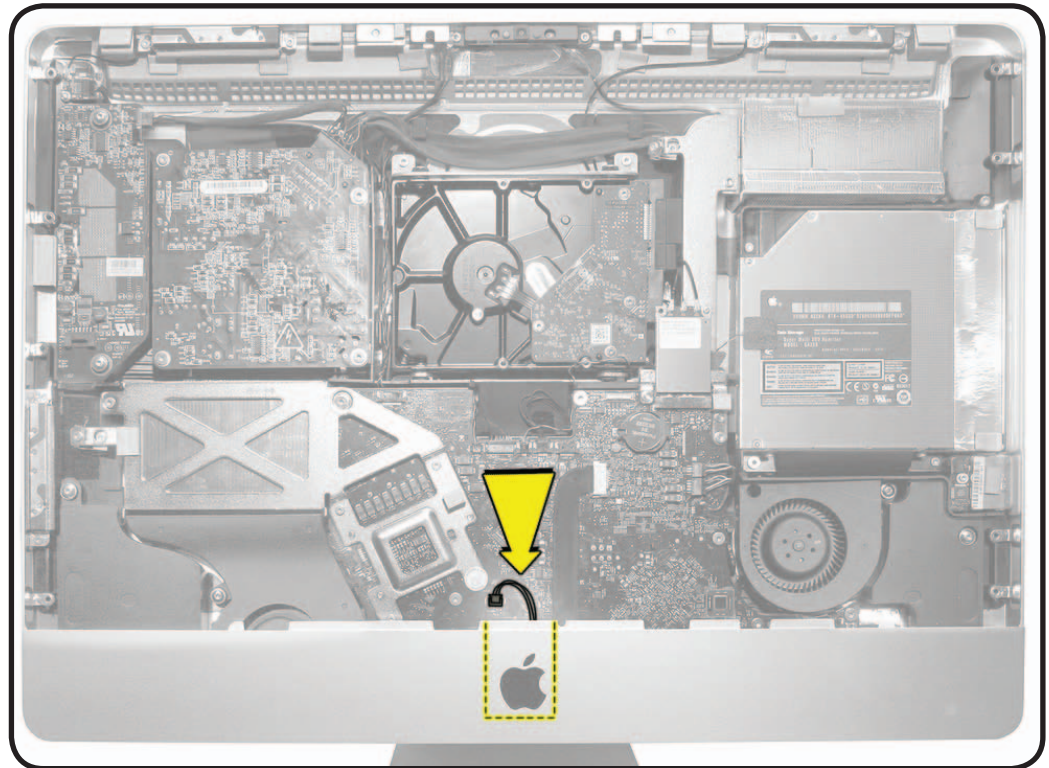

## Tools

- ESD wrist strap





## Removal

- 1 Disconnect IR cable from logic board.
- 2 With 2 fingers, wiggle IR mounting bracket up and off mounting post.

### Reassembly Note:

Pull the front housing out slightly to make room for IR mounting bracket to slide onto IR mounting post.

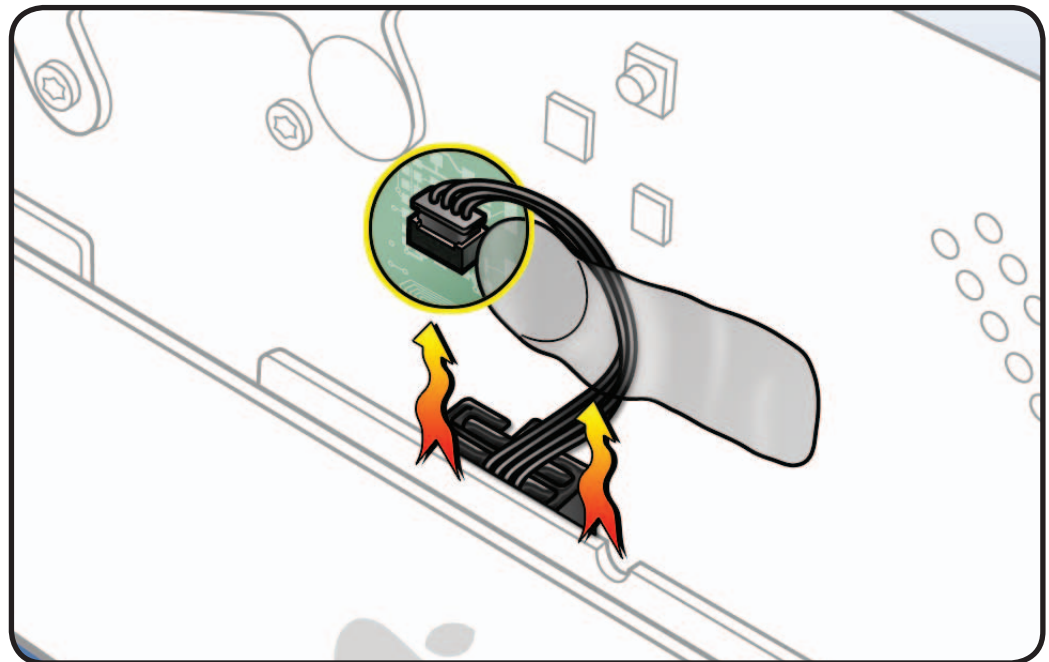



# Logic Board

## First Steps

Remove:

- Access Door
- Memory

**Tip:** The logic board is much easier to reinstall if memory is removed.

- Glass Panel
- LCD Panel
- Power Supply
- Backlight Pressure Wall
- Hard Drive (if present in this configuration)
- Power Supply Pressure Wall
- Optical Drive
- Optical Drive Fan
- IR Board

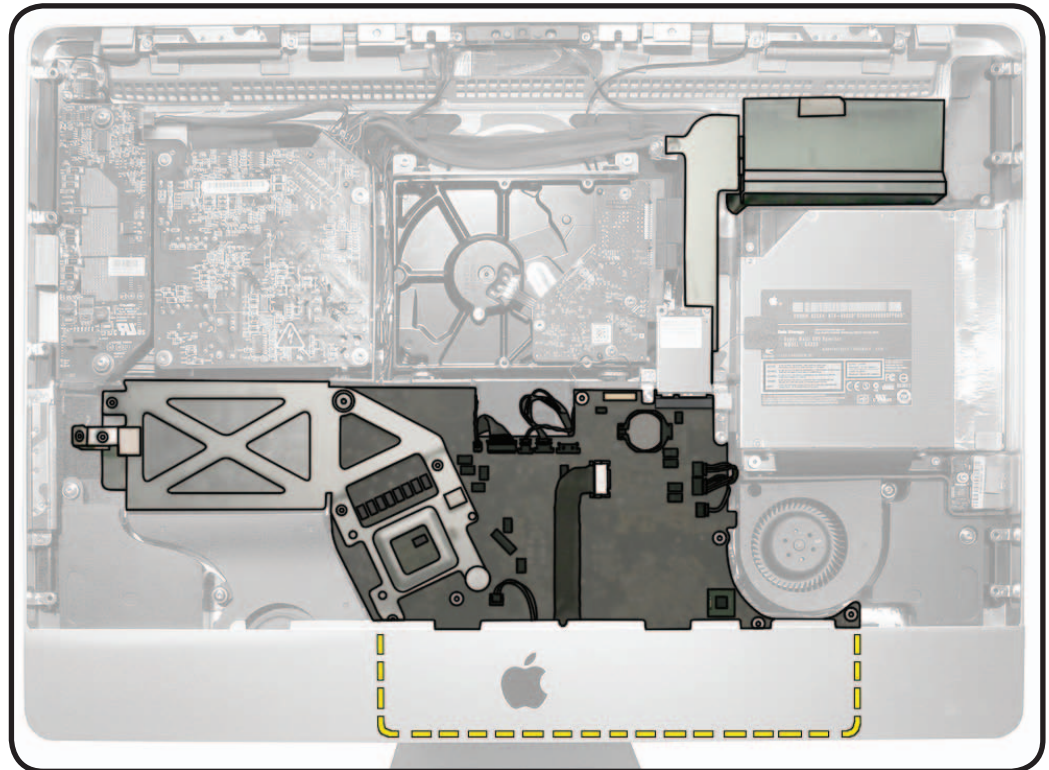

## Tools

- ESD wrist strap
- Torx T10 screwdriver
- USB and Mini DisplayPort cables for reassembly

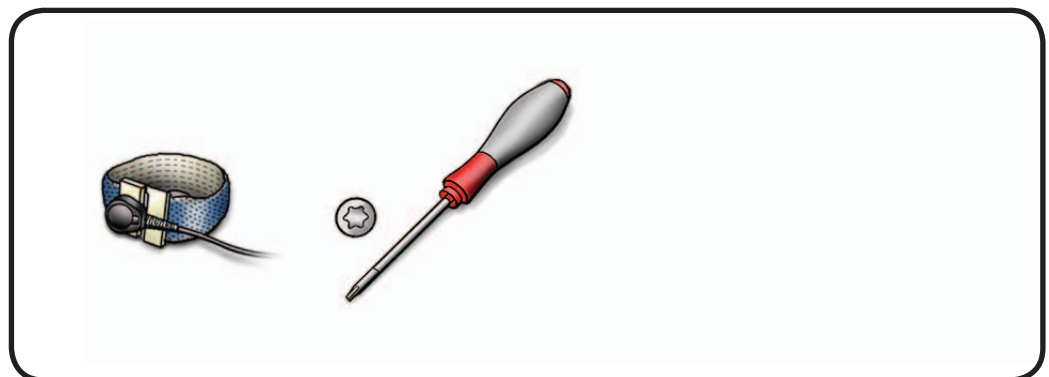



## Removal

### 1 Remove T10 screws:

- (2) 922-6800, short (S)



- (2) 922-9883, medium 20mm (M)



- (2) 922-9884, long 24mm (L)



- (1) 922-9881, extra long 29mm (X)

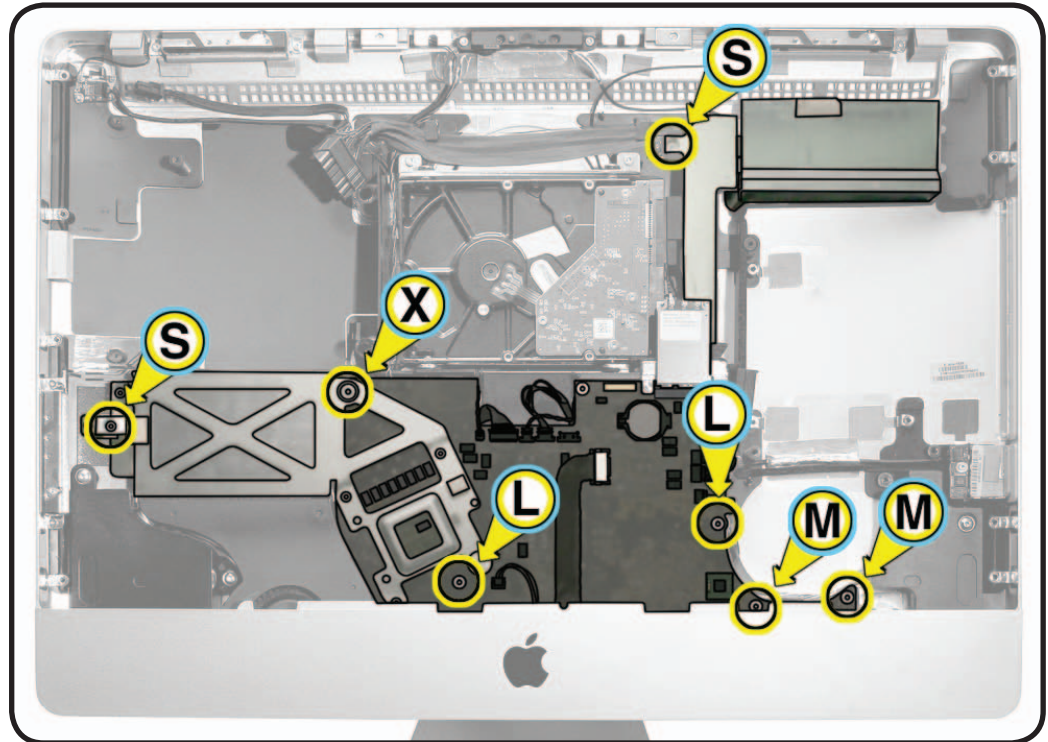

### IMPORTANT Reassembly

**Note:** The Thunderbolt port has a precise fit. To properly align logic board with rear housing, you **MUST** plug in cables to the Thunderbolt port and also to the furthest left USB port while tightening screws.

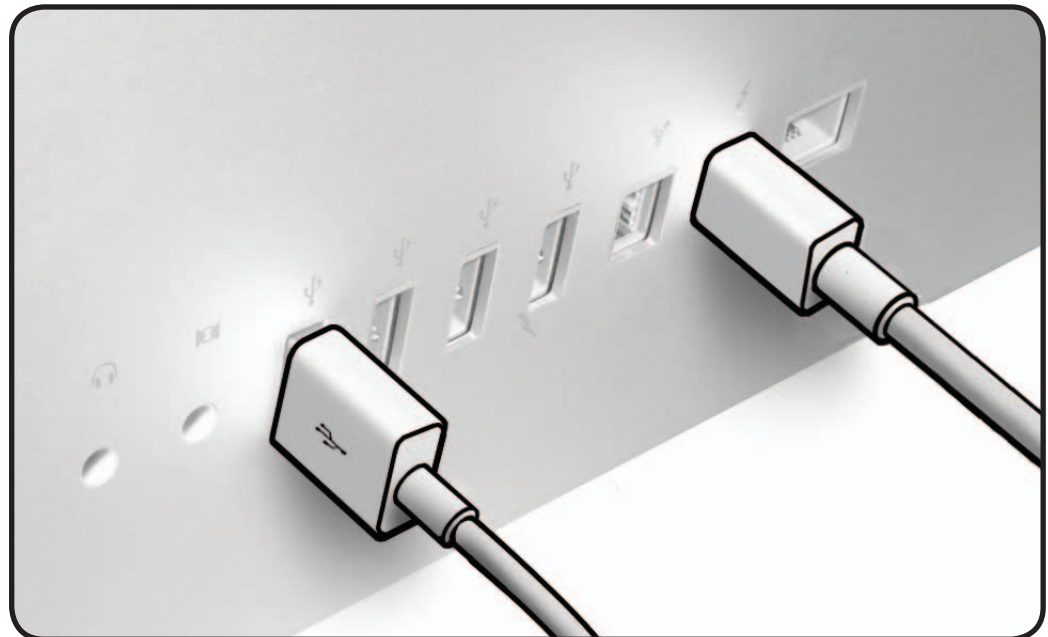



**2** Disconnect cables from left side of logic board:

- CPU fan (1)
- power button (2)

**Note:** IR cable (3) should have been disconnected already.

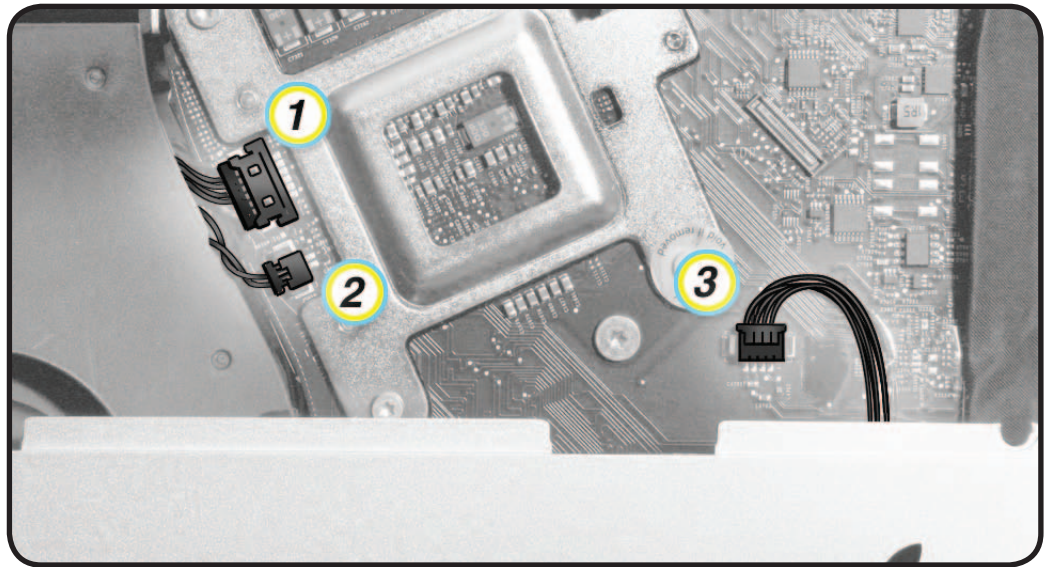

**3** Disconnect cables from top center of logic board:

- skin temp sensor (4)
- Bluetooth/camera/sensor (5)
- hard drive fan (7)
- audio I/O (9)
- right speaker (12)
- left speaker (13)
- microphone (14)

AirPort card (11) only needs to be removed if you are replacing the logic board or video card bracket.

**Note:** Optical drive sensor (6), DisplayPort power (8), and DisplayPort (10) cables should have been disconnected already.

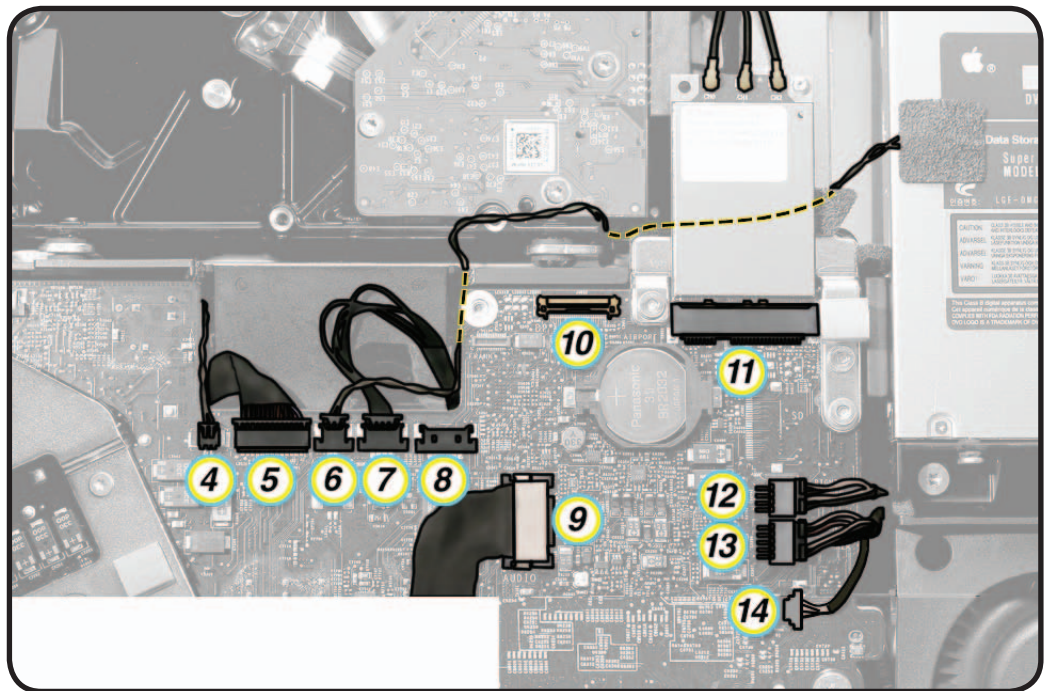



- 4** Disconnect SD card reader cable (15) from lower right side of logic board:

**Note:** Optical drive fan cable (16) should have been disconnected already.

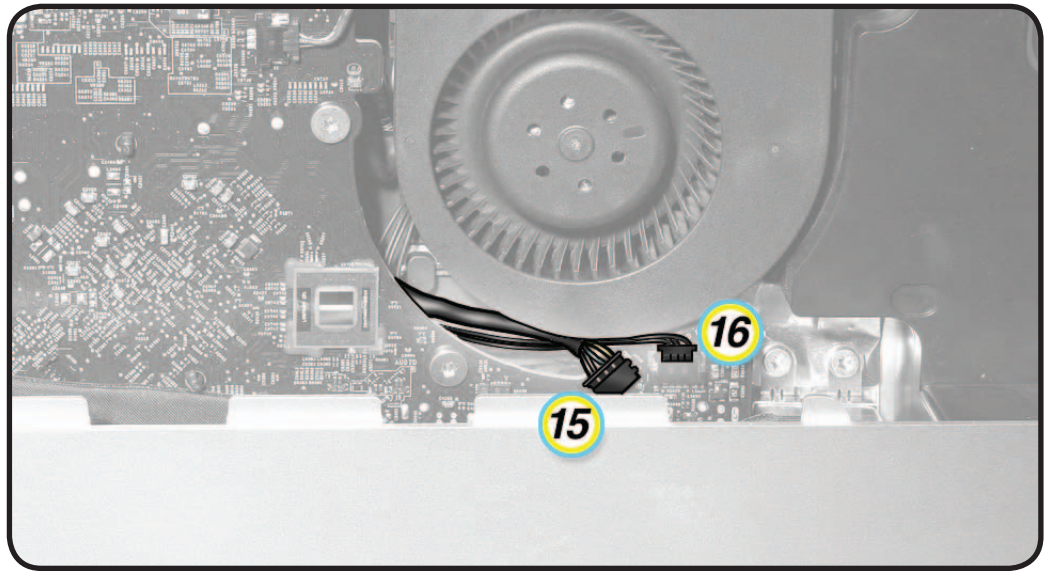

- 5** Tape cables back so they do not get trapped under logic board during reassembly.

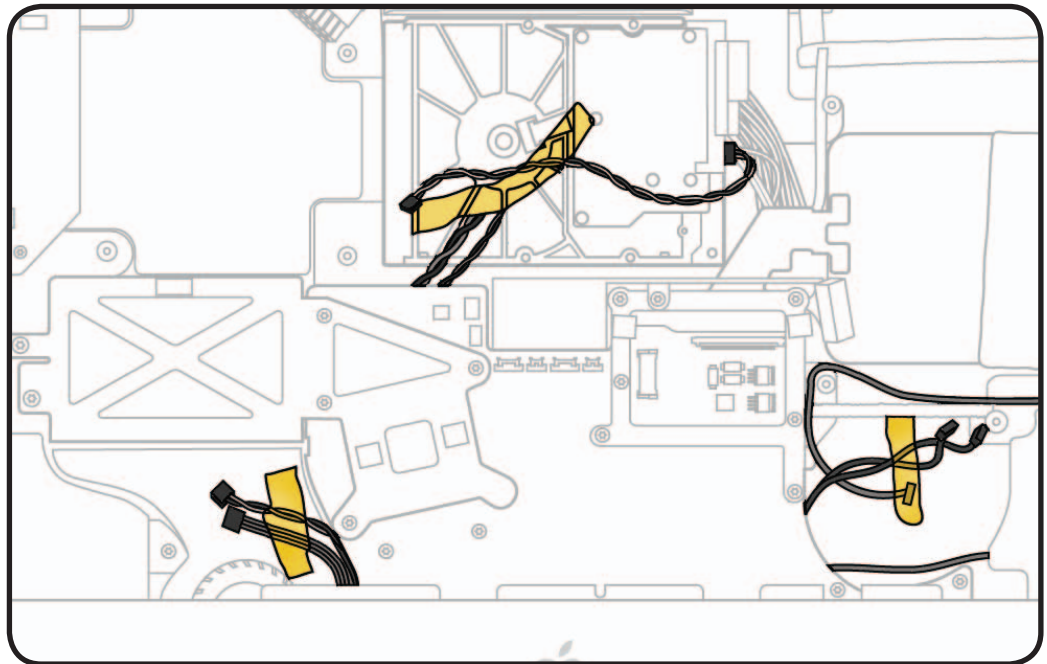



- 6 Begin to lift logic board, with attached video card, up and out of rear housing “chin”.

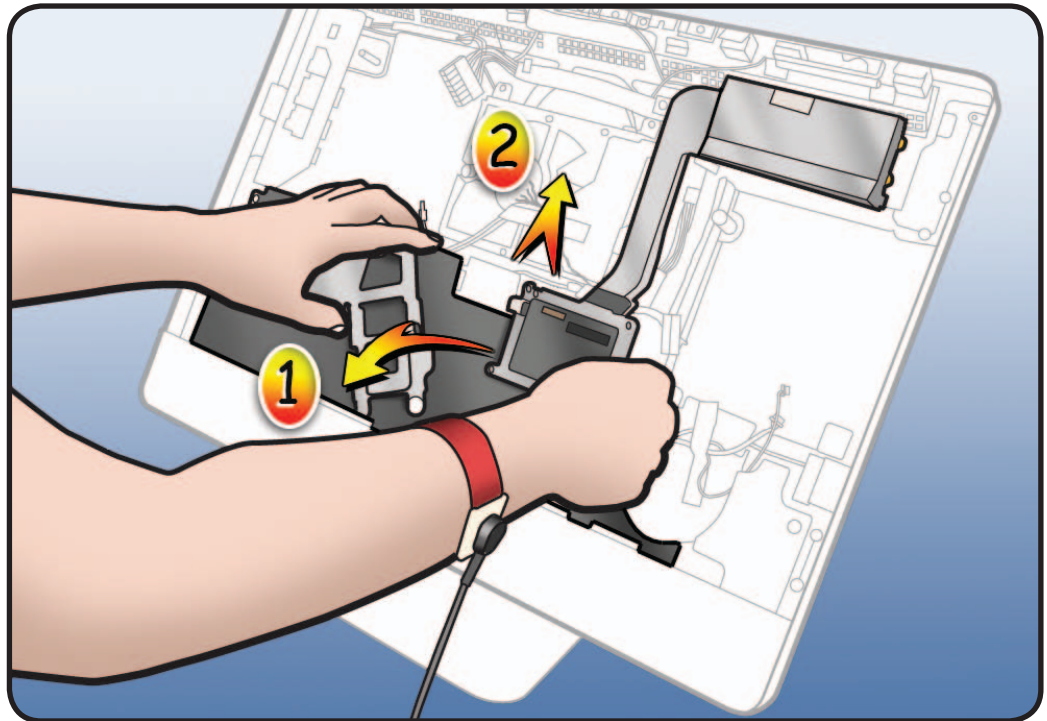

**Careful!** There are several cables connected to the back side of logic board.

See cable details on next page.

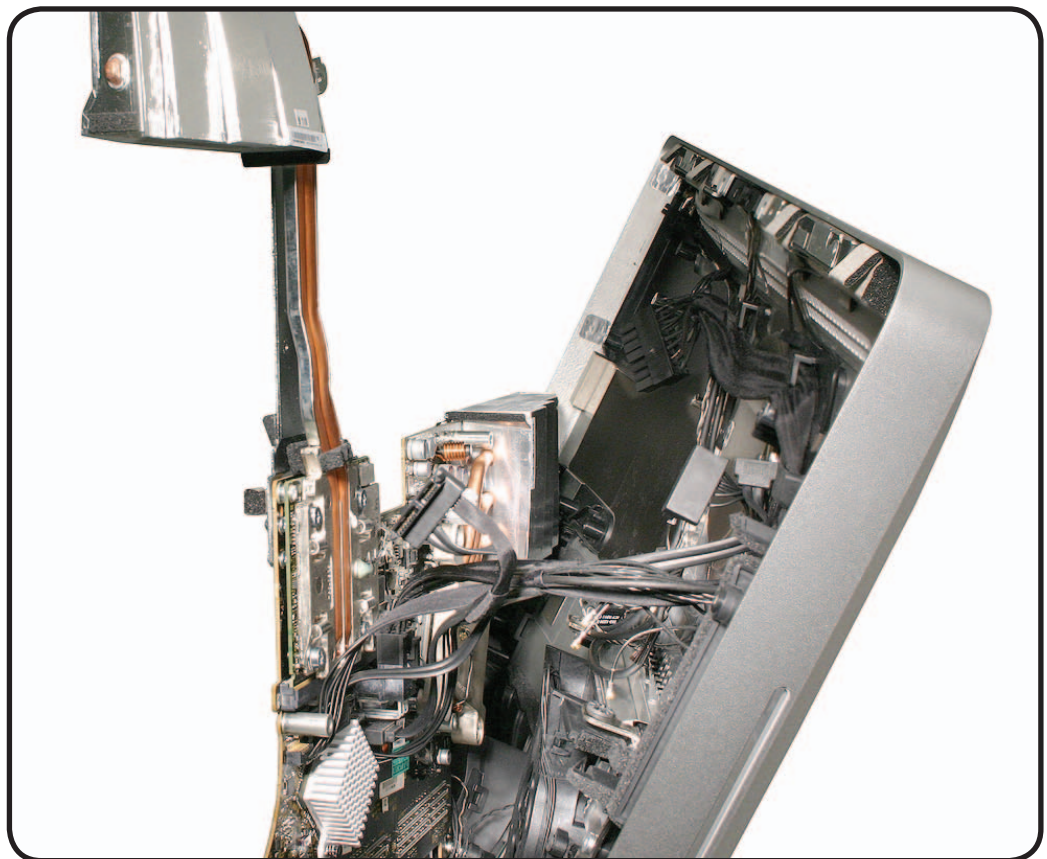



- 7** You can either:
- Disconnect cables from back of logic board before removing logic board from rear housing, or
  - Bring all the cables out with the logic board as you remove it from rear housing. This makes it much easier to see the cable connectors.

**Reassembly Note:**

Observe cable routing along back of logic board.

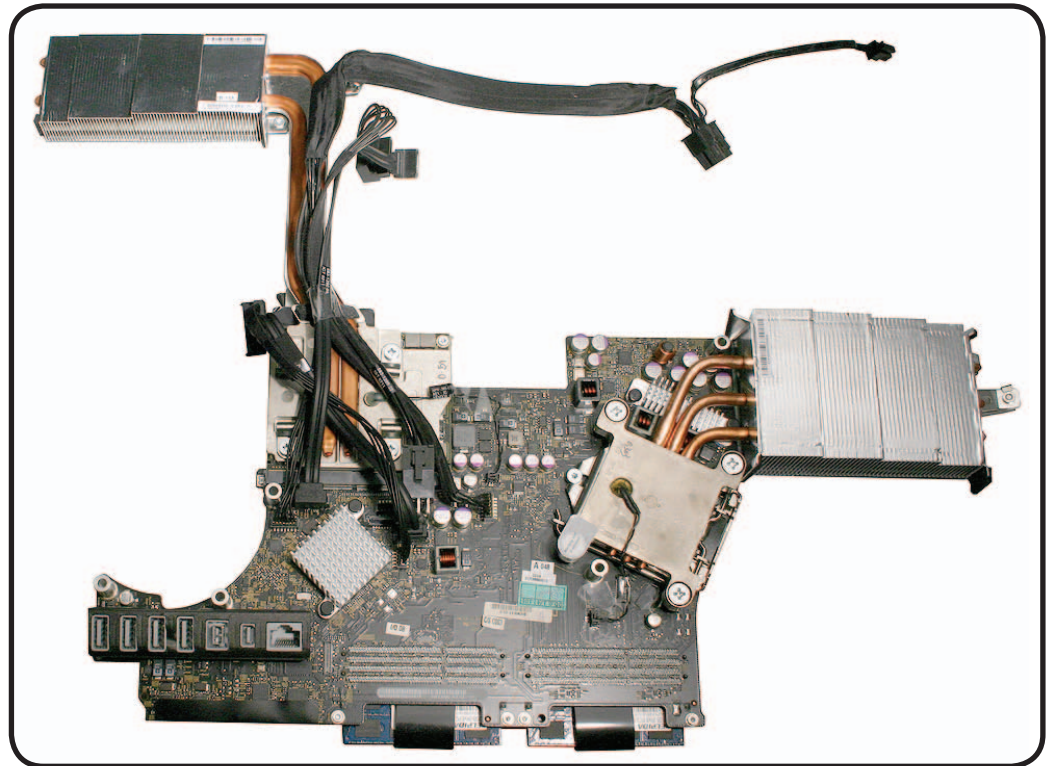

- 8** Disconnect cables from back of logic board:
- HDD power (17)
  - HDD data (18)
  - SSD power (19)
  - SSD data (20)
  - ODD data (21)
  - ODD power (22)
  - DC power (23/24)

**Note:** Depending on the configuration, there may be HDD and/or SSD cables.

**Reassembly Note:**

The HDD or SSD data and power cables are taped to the DC power cable.

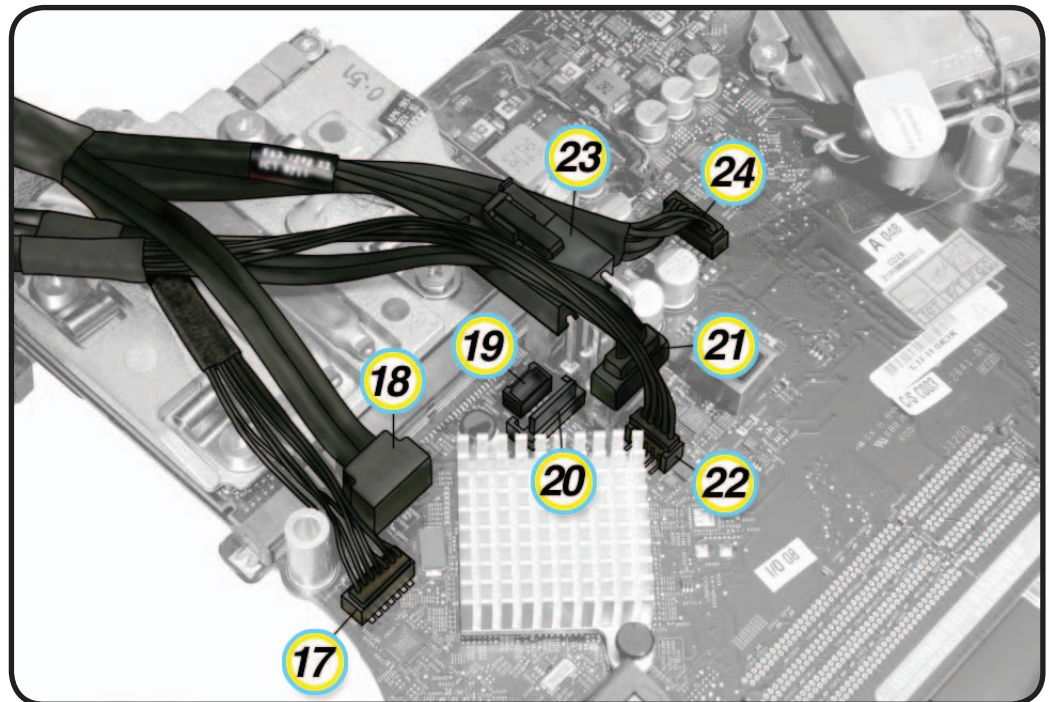



**Important:** Always use two hands to support logic board and heat sink. Handling board incorrectly could flex board and damage chips and circuits. **Never** handle board by heat sink or metal frame.

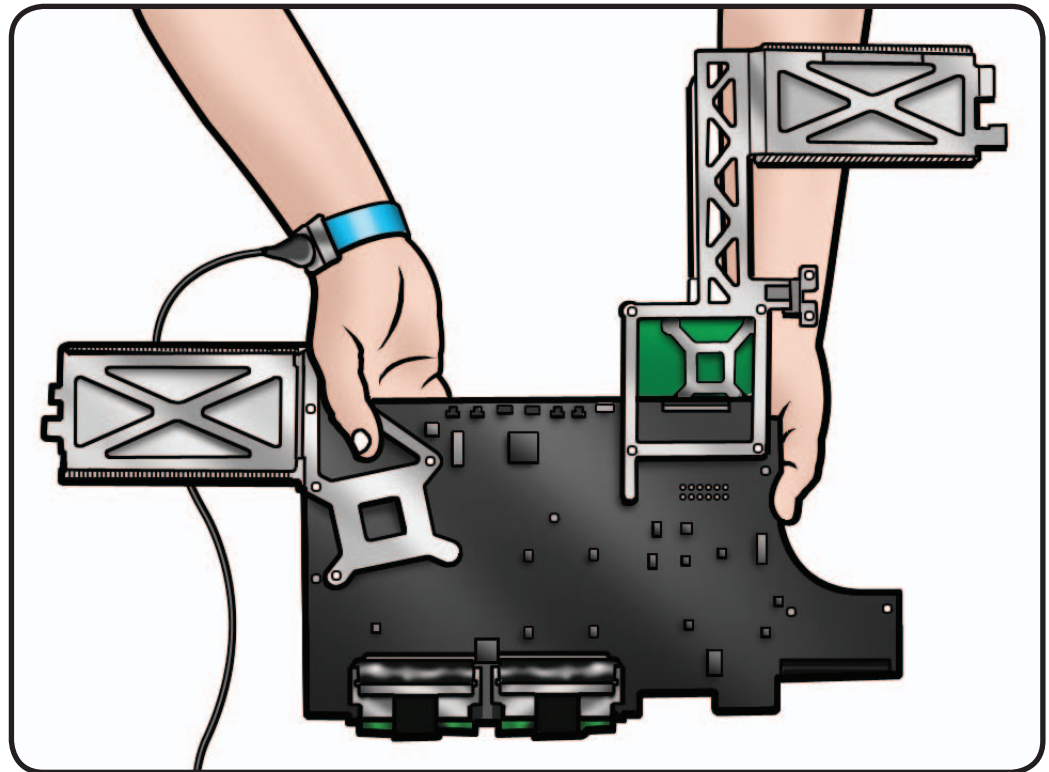



## Replacement

If installing a new replacement logic board, note 4 things:

- 1 Verify that tamper indicator labels on front and back of heat sink assembly are intact. If labels have been removed or tampered with, logic board is not eligible for exchange.
- 2 Transfer the following to new logic board:
  - video card bracket
  - video card
  - memory (install after logic board is in place)
- 3 Apply new Ethernet ID label (included in box with new logic board) to bottom of stand.
- 4 Use the [Blank Board Serializer tool](#) to set computer's serial number on new logic board.

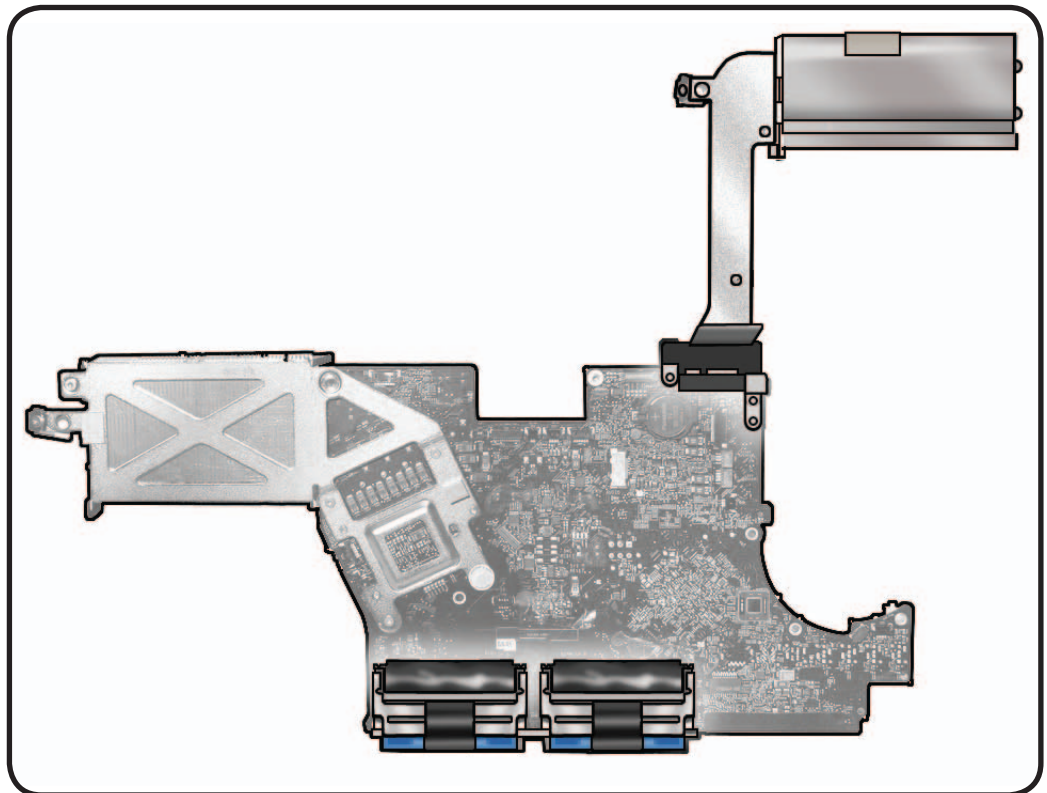
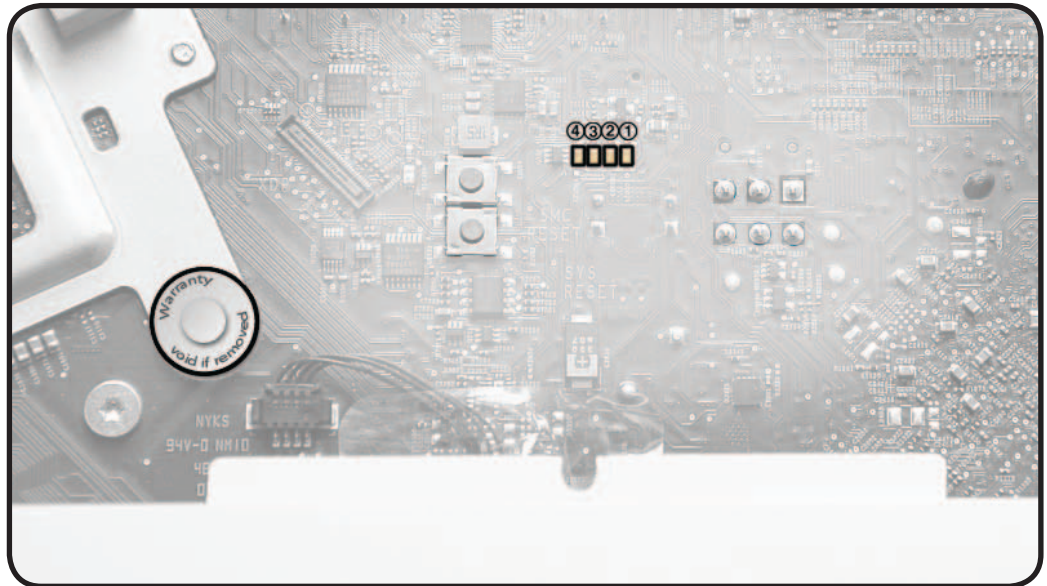



# Video Card

## First Steps

Remove:

- Glass Panel
- LCD Panel
- Power Supply
- Backlight Pressure Wall
- Hard Drive (if present in this configuration)
- Power Supply Pressure Wall
- Optical Drive
- Optical Drive Fan
- IR Board
- Logic Board

**Note:** Video card attaches to back side of logic board.

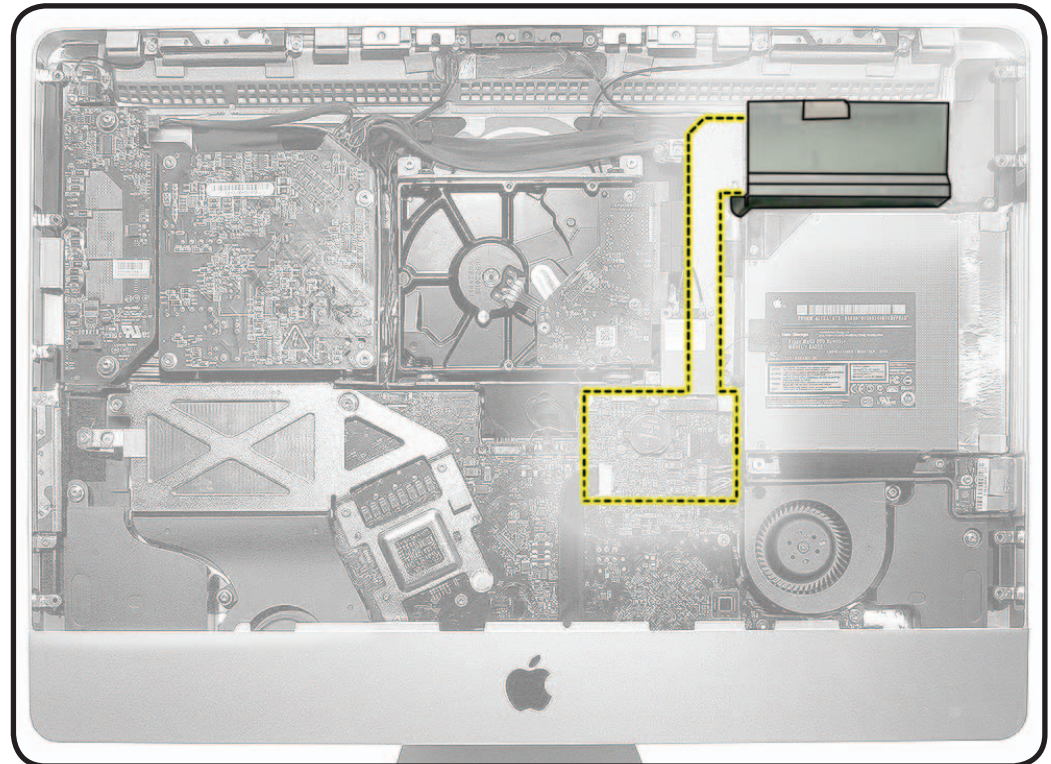

## Tools

- ESD wrist strap
- Torx T10 screwdriver
- Torx T8 screwdriver

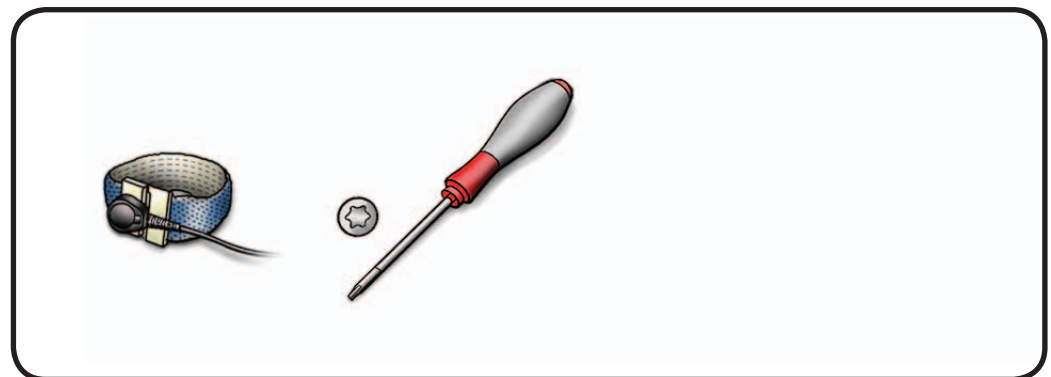



## Removal

- 1 Remove T10 screw near heat sink:  
(1) 922-7971



- 2 Remove T8 screws on video card:  
(2) 922-4723



- 3 Disconnect cable from logic board.

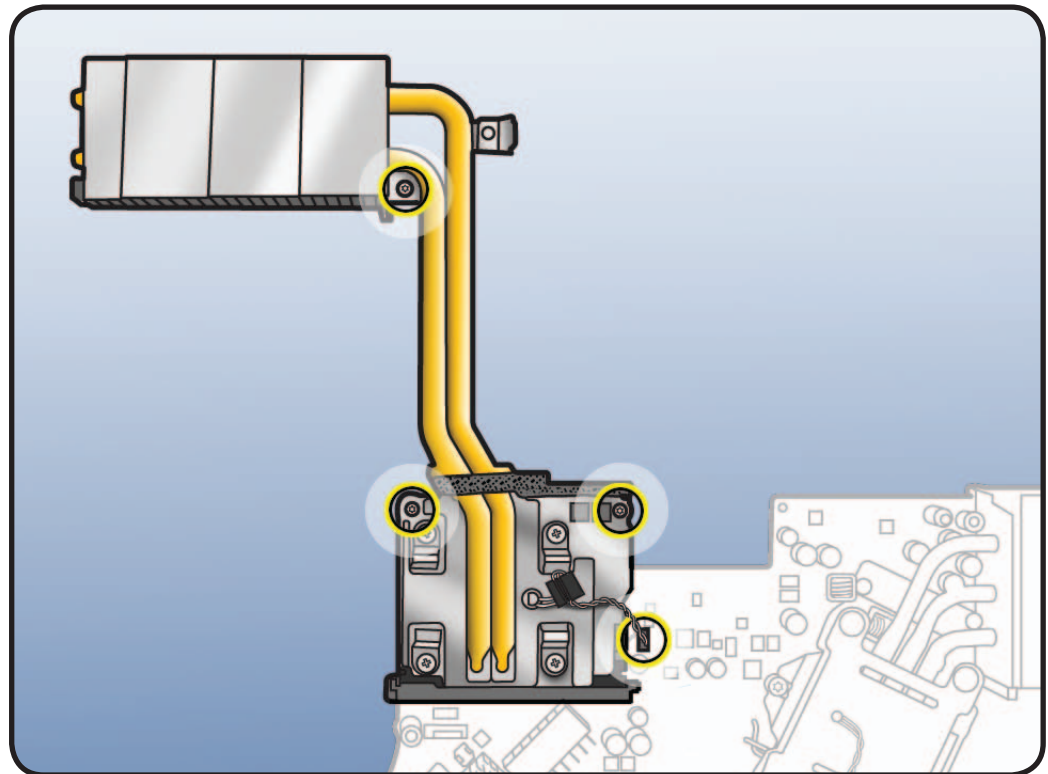

- 4 (1) Lift up video card and heat sink and  
(2) slide card out of slot on logic board.

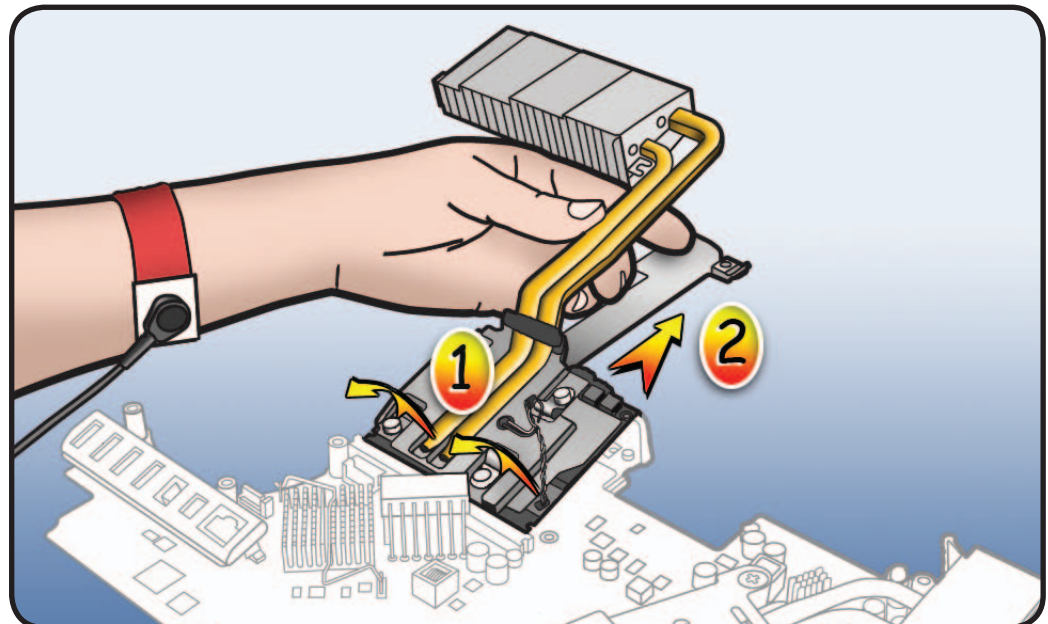



# Video Card Bracket

## First Steps

Remove:

- Glass Panel
- LCD Panel
- Power Supply
- Backlight Pressure Wall
- Hard Drive (if present in this configuration)
- Power Supply Pressure Wall
- Optical Drive
- Optical Drive Fan
- IR Board
- Logic Board
- Video Card
- AirPort Card

**Note:** Video card bracket attaches to back side of logic board.

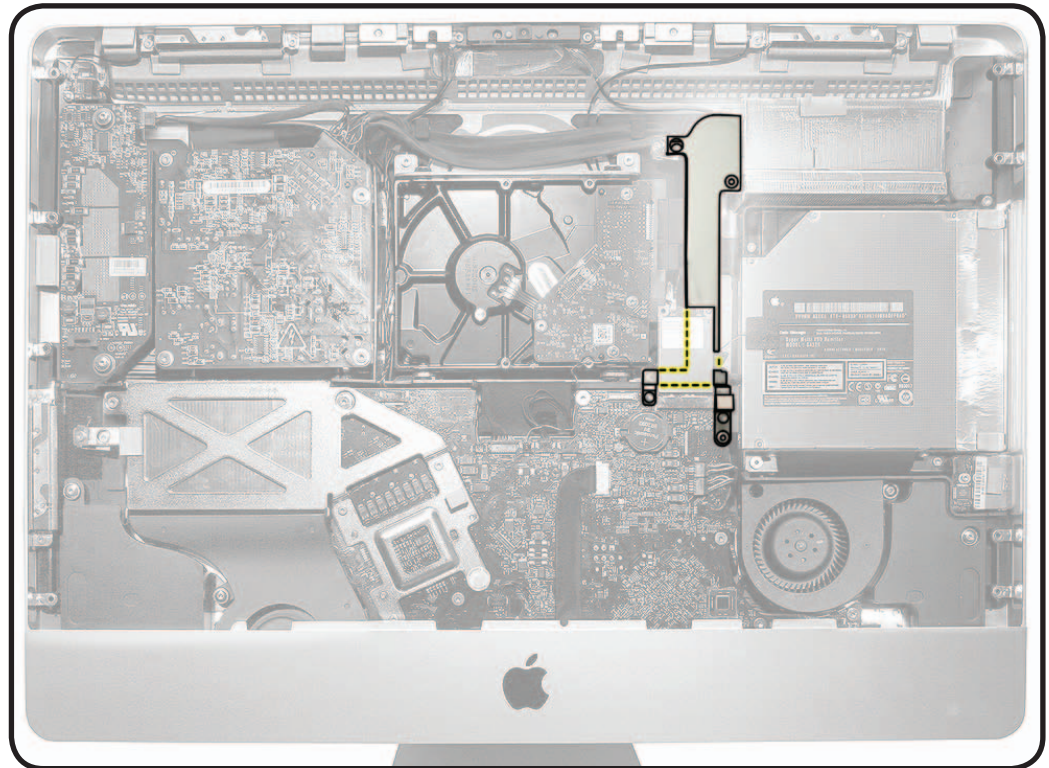

## Tools

- ESD wrist strap
- Torx T8 screwdriver

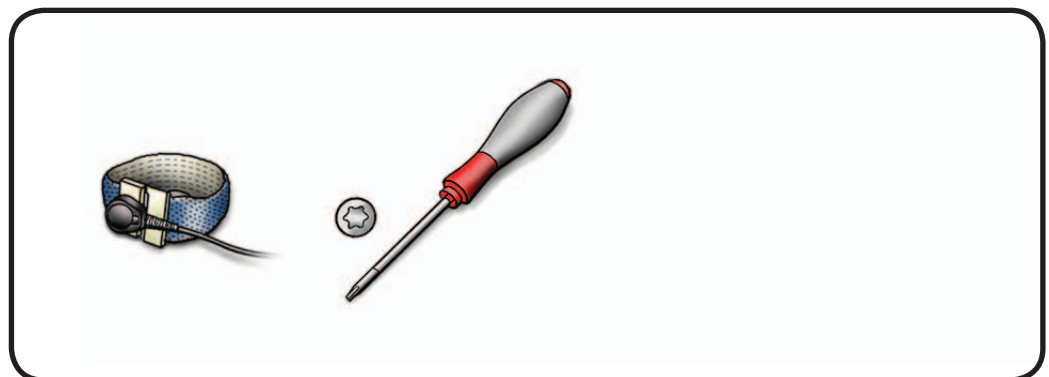



## Removal

- 1 Remove T8 screws from back of logic board:  
(3) 922-4723



- 2 Remove bracket from logic board.

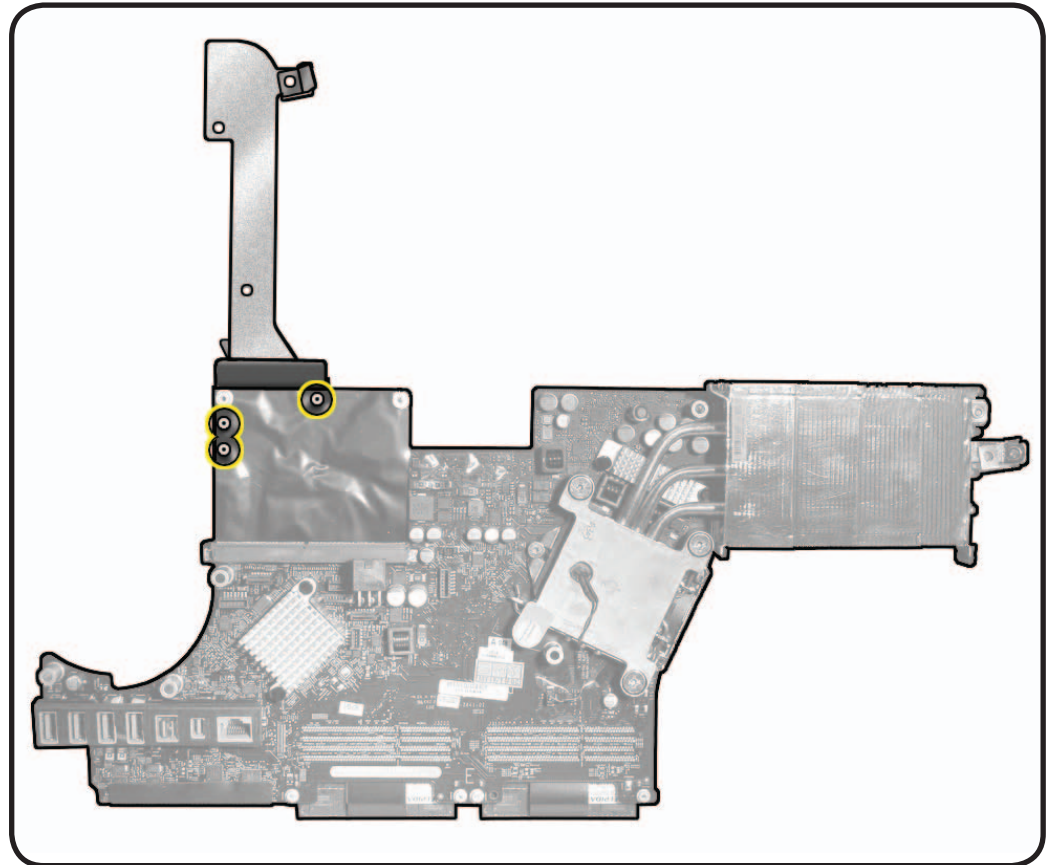



# ODD Data/Power Cable

## First Steps

Remove:

- Glass Panel
- LCD Panel
- Power Supply
- Backlight Pressure Wall
- Hard Drive (if present in this configuration)
- Power Supply Pressure Wall
- Optical Drive
- Optical Drive Fan
- IR Board
- Logic Board

**Note:** One end of ODD data/power cable attaches to back side of logic board.

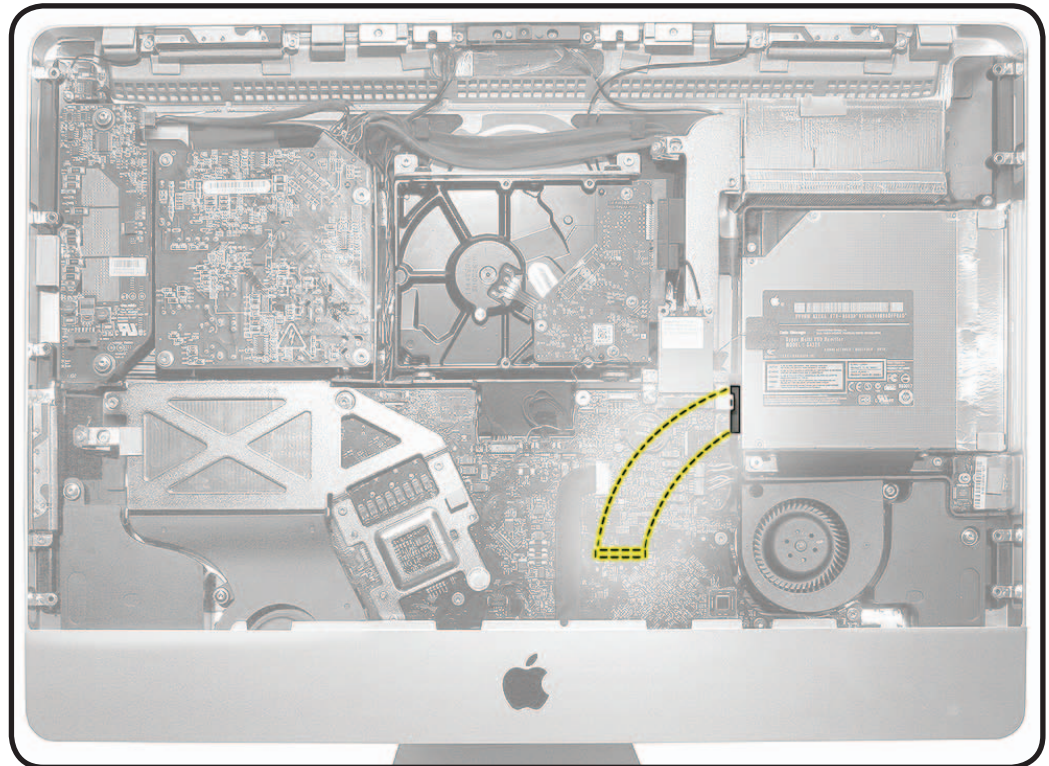

## Tools

- ESD wrist strap





## Removal

- 1 Cable should have been disconnected already from optical drive.

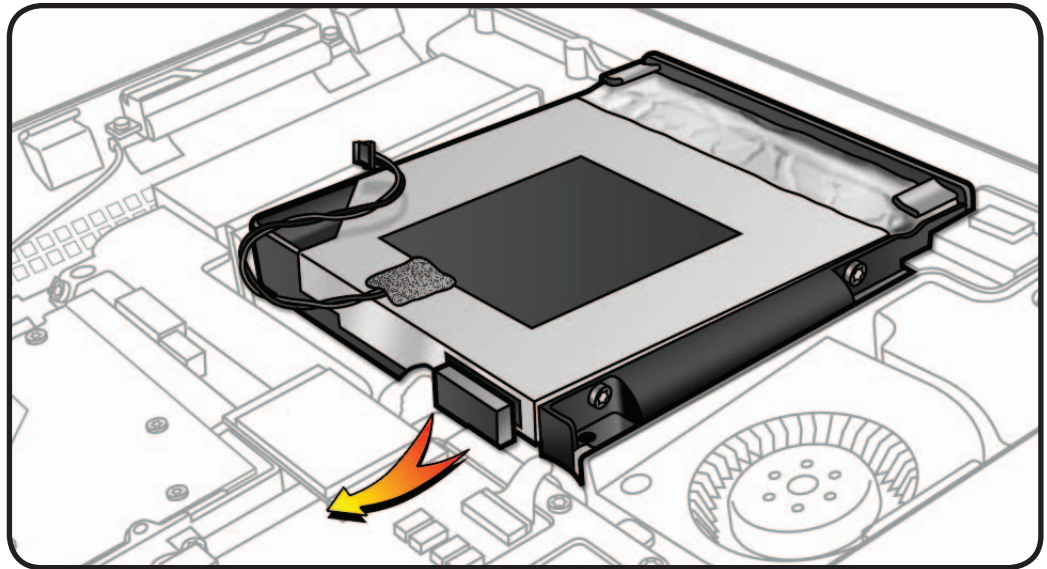

- 2 Disconnect ODD data (#21) and power (#22) cables from back side of logic board.

**Note:** This end of the cable has two heads.

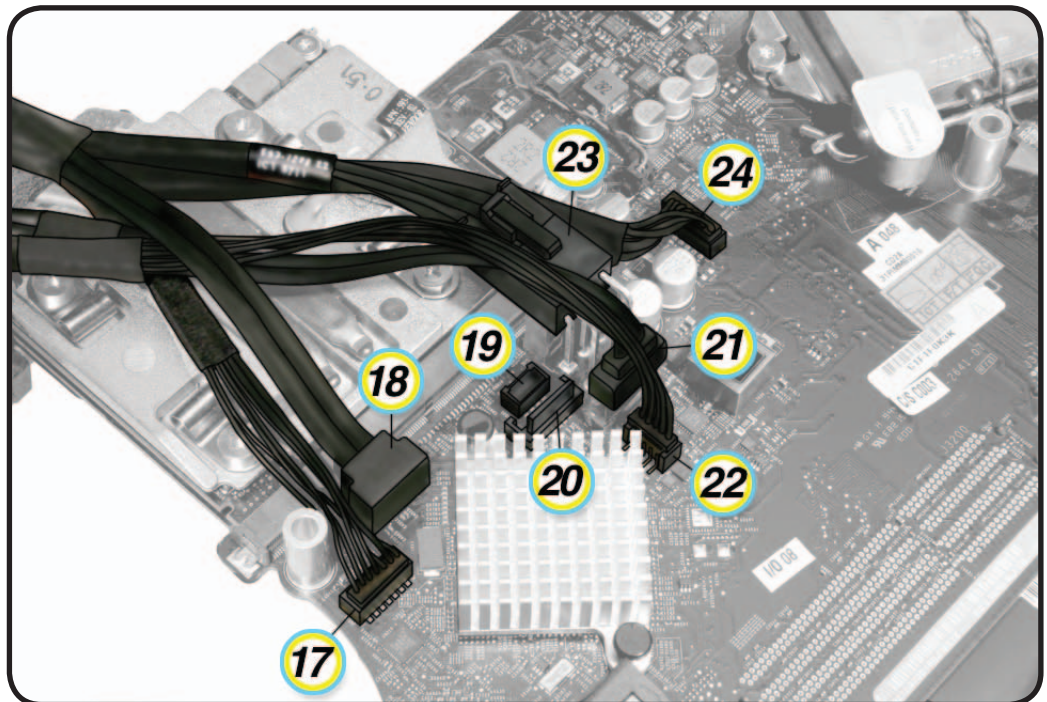



# HDD Data Cable

## First Steps

Remove:

- Glass Panel
- LCD Panel
- Power Supply
- Backlight Pressure Wall
- Hard Drive
- Power Supply Pressure Wall
- Optical Drive
- Optical Drive Fan
- IR Board
- Logic Board

**Note:** One end of HDD data cable attaches to back side of logic board.

**Note:** This cable is only present in configurations that have a hard drive.

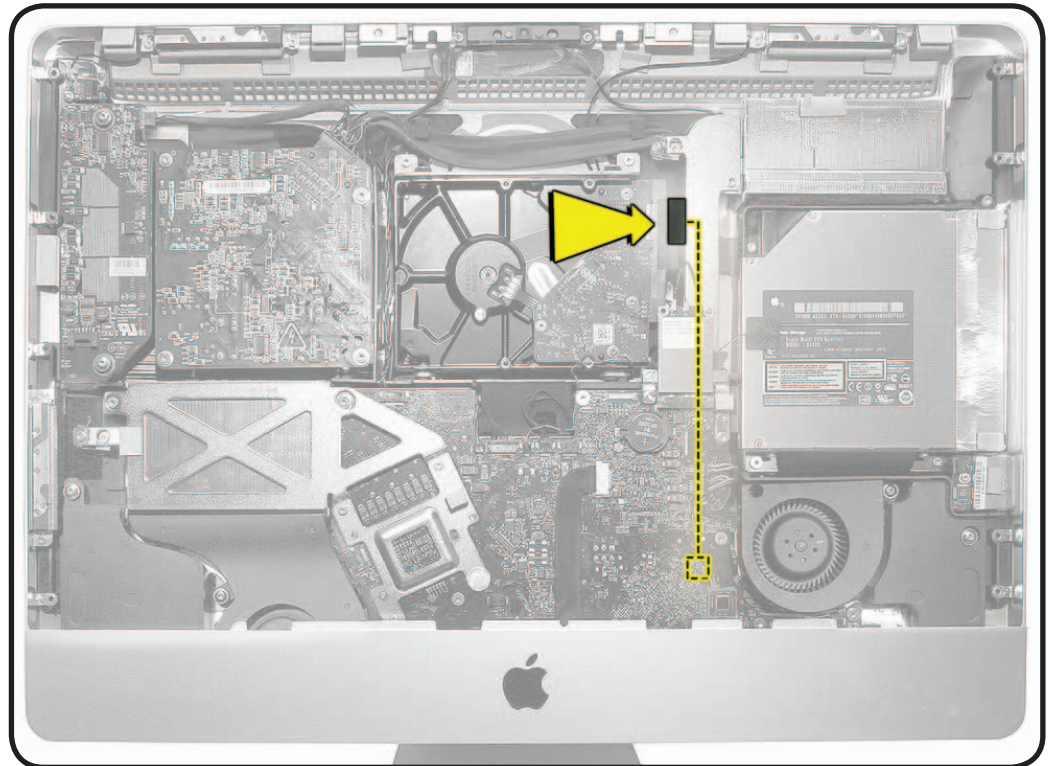

## Tools

- ESD wrist strap





## Removal

- 1 Cable should have been disconnected already from hard drive.

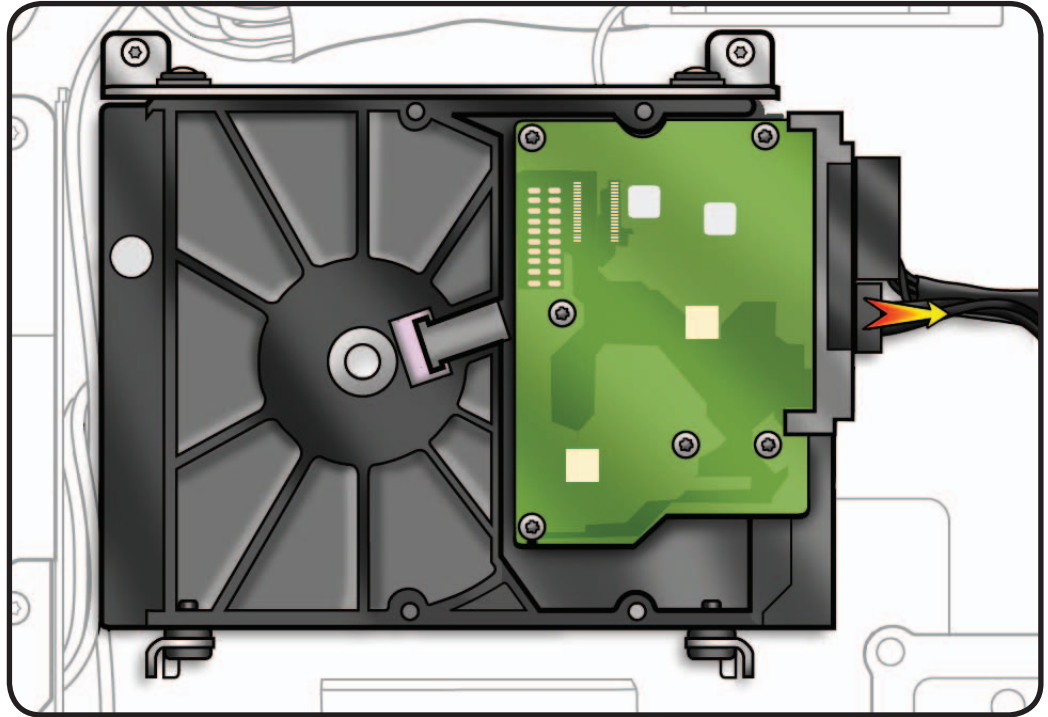

- 2 Disconnect HDD data cable (#18) from back side of logic board.

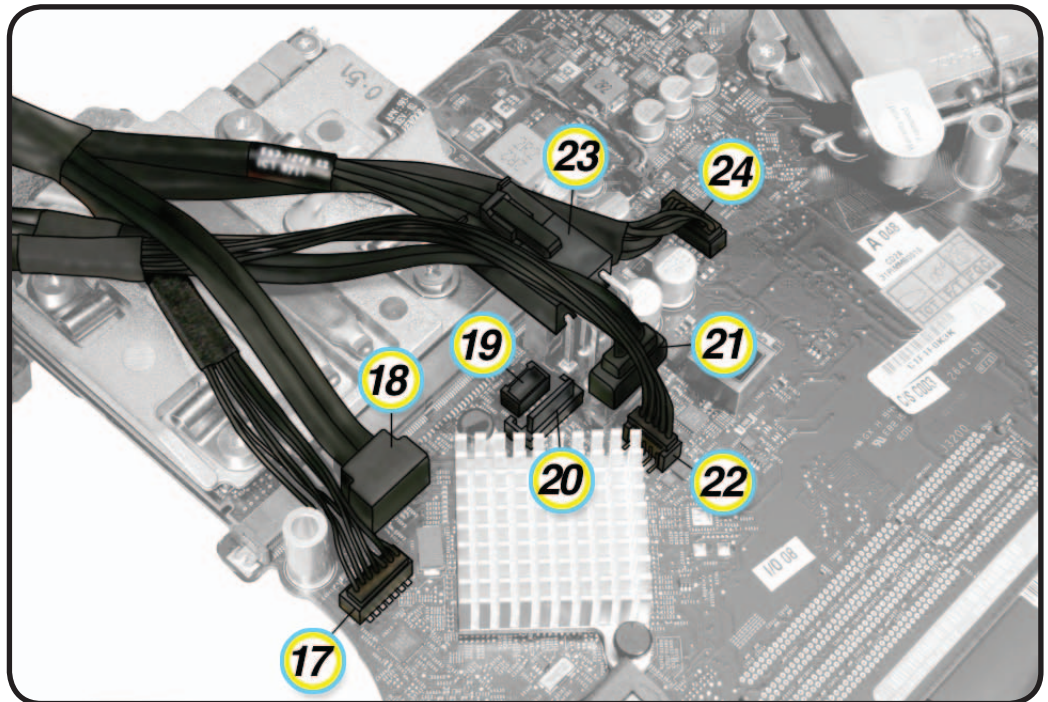



# HDD Power Cable

## First Steps

Remove:

- Glass Panel
- LCD Panel
- Power Supply
- Backlight Pressure Wall
- Hard Drive
- Power Supply Pressure Wall
- Optical Drive
- Optical Drive Fan
- IR Board
- Logic Board

**Note:** One end of HDD power cable attaches to back side of logic board.

**Note:** This cable is only present in configurations that have a hard drive.

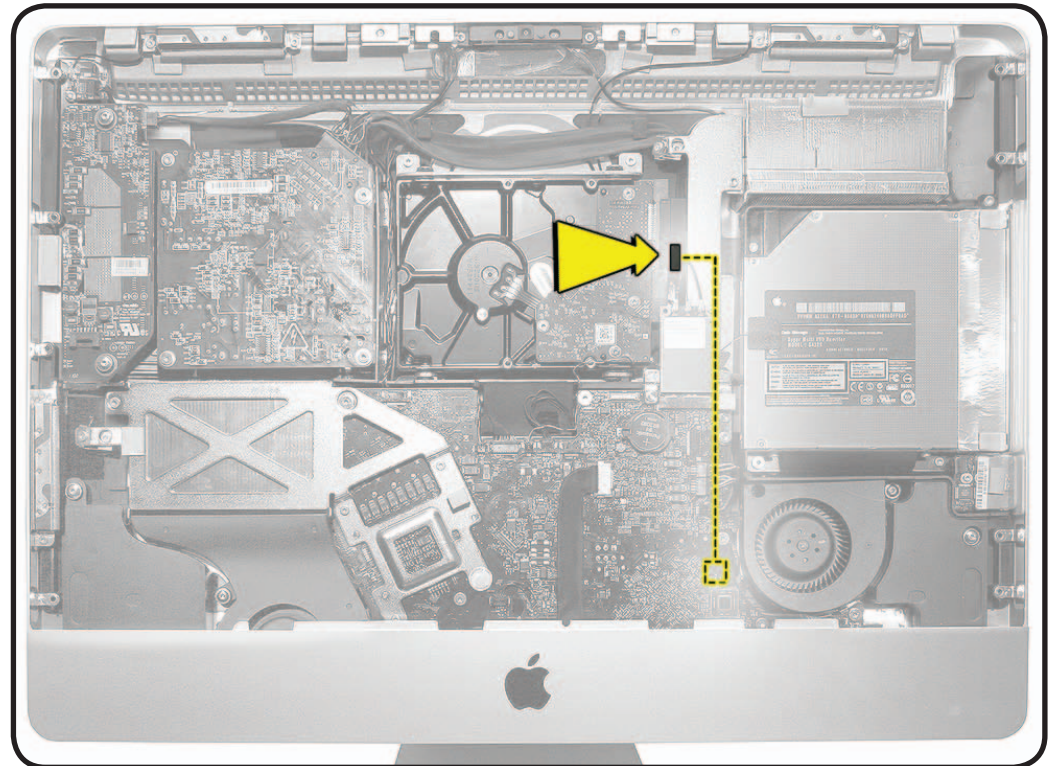

## Tools

- ESD wrist strap





## Removal

- 1 Cable should have been disconnected already from hard drive.

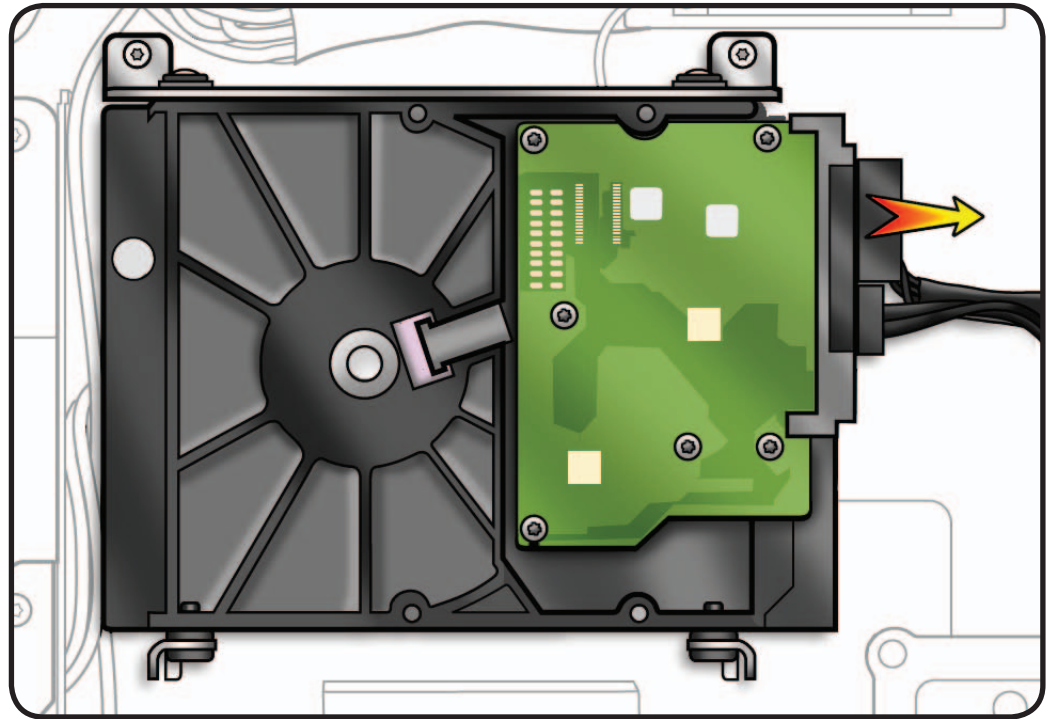

- 2 Disconnect HDD power cable (#17) from back side of logic board.

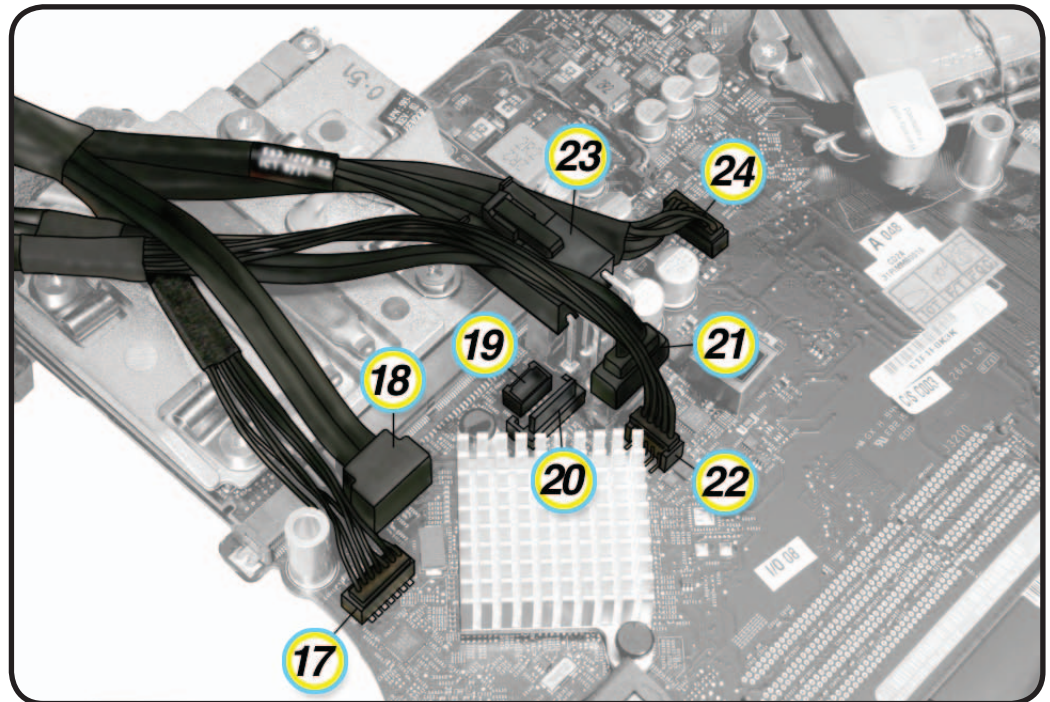



# DC Power Cable

## First Steps

Remove:

- Glass Panel
- LCD Panel
- LED Backlight Board
- Power Supply
- Backlight Pressure Wall
- Hard Drive (if present in this configuration)
- Power Supply Pressure Wall
- Optical Drive
- Optical Drive Fan
- IR Board
- Logic Board

**Note:** This cable attaches to LED backlight board, power supply, and the back of the logic board.

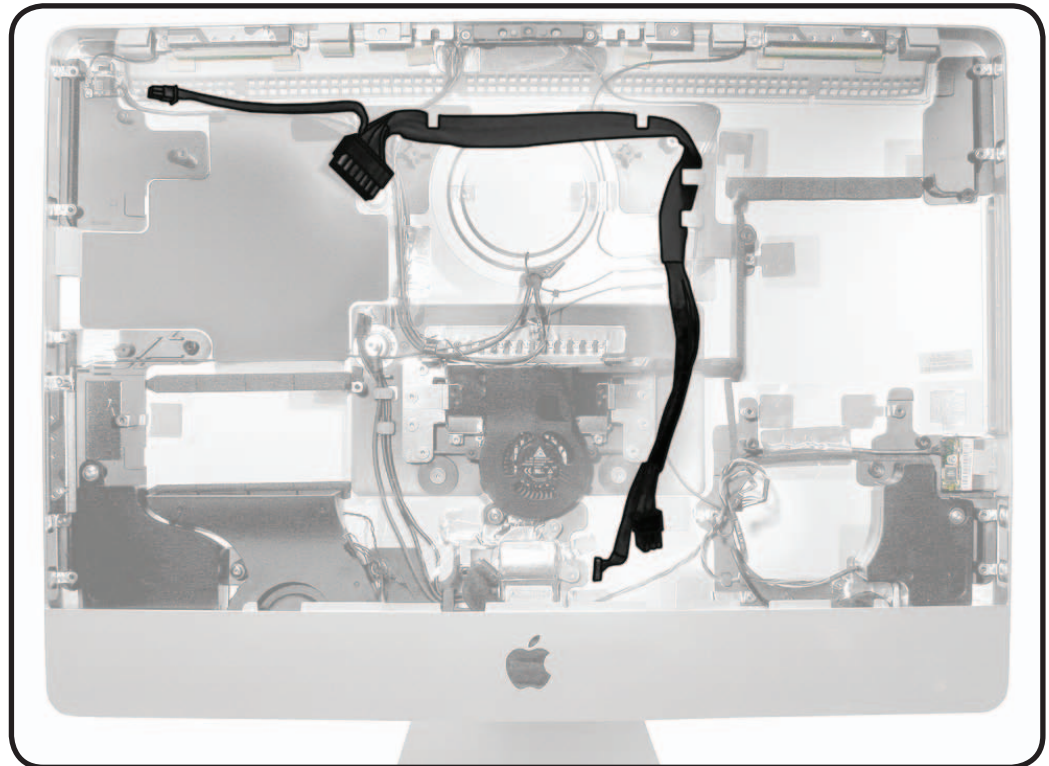

## Tools

- ESD wrist strap





## Removal

- 1 Cable should have been disconnected already from LED backlight board.

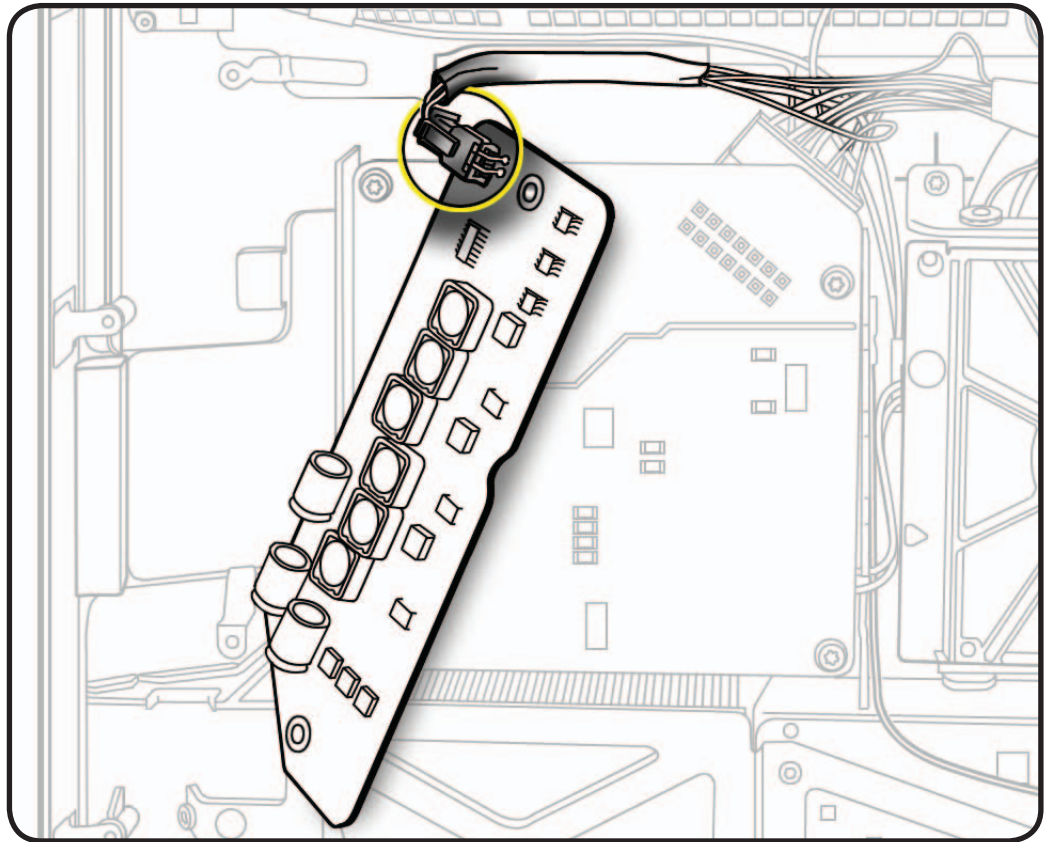

- 2 Cable should have been disconnected already from power supply.

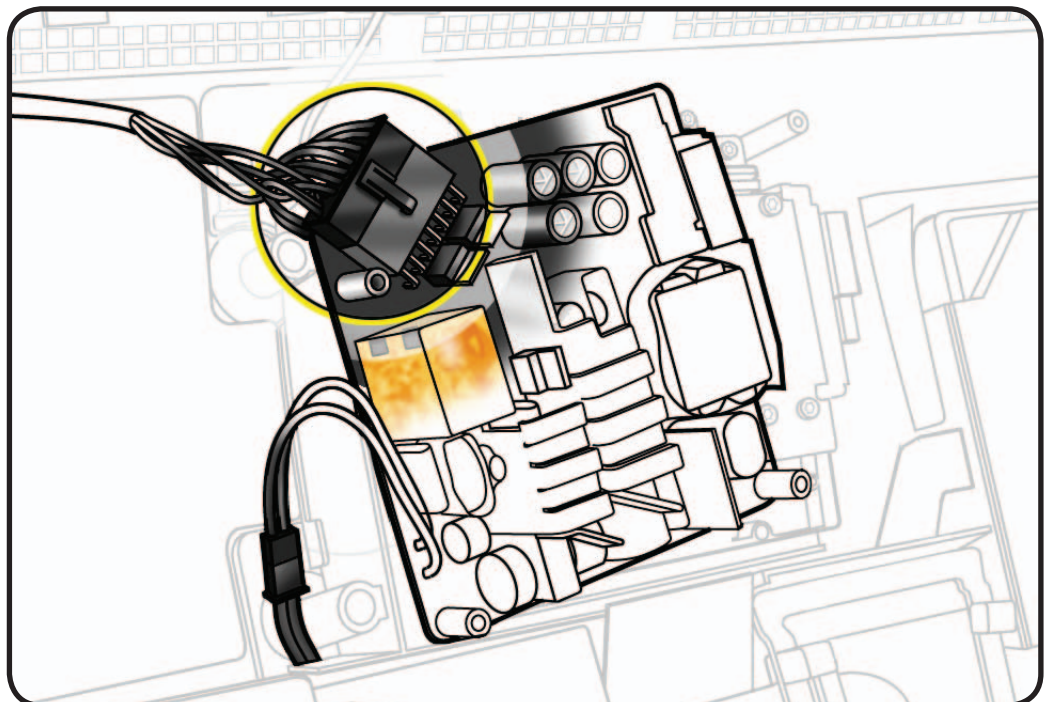



- 3** Disconnect DC power cable (#23 and #24) from back side of logic board.

**Note:** This end of the cable has two heads.

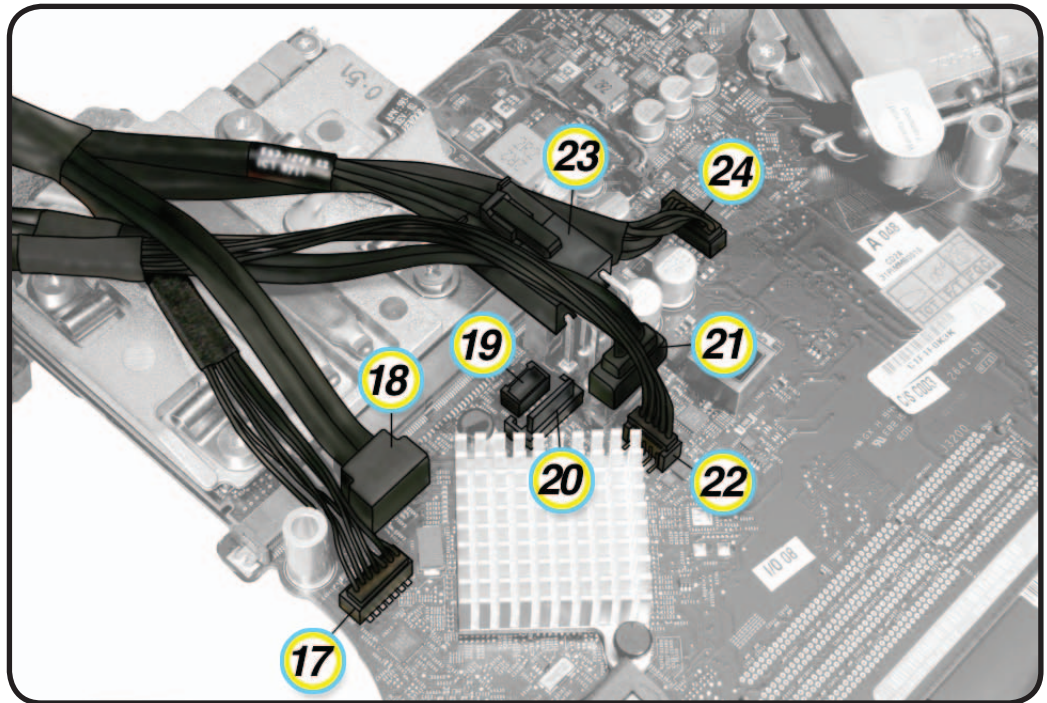



# Optical Drive Pressure Wall

## First Steps

Remove:

- Glass Panel
- LCD Panel
- Power Supply
- Backlight Pressure Wall
- Hard Drive (if present in this configuration)
- Power Supply Pressure Wall
- Optical Drive
- Optical Drive Fan
- IR Board
- Logic Board

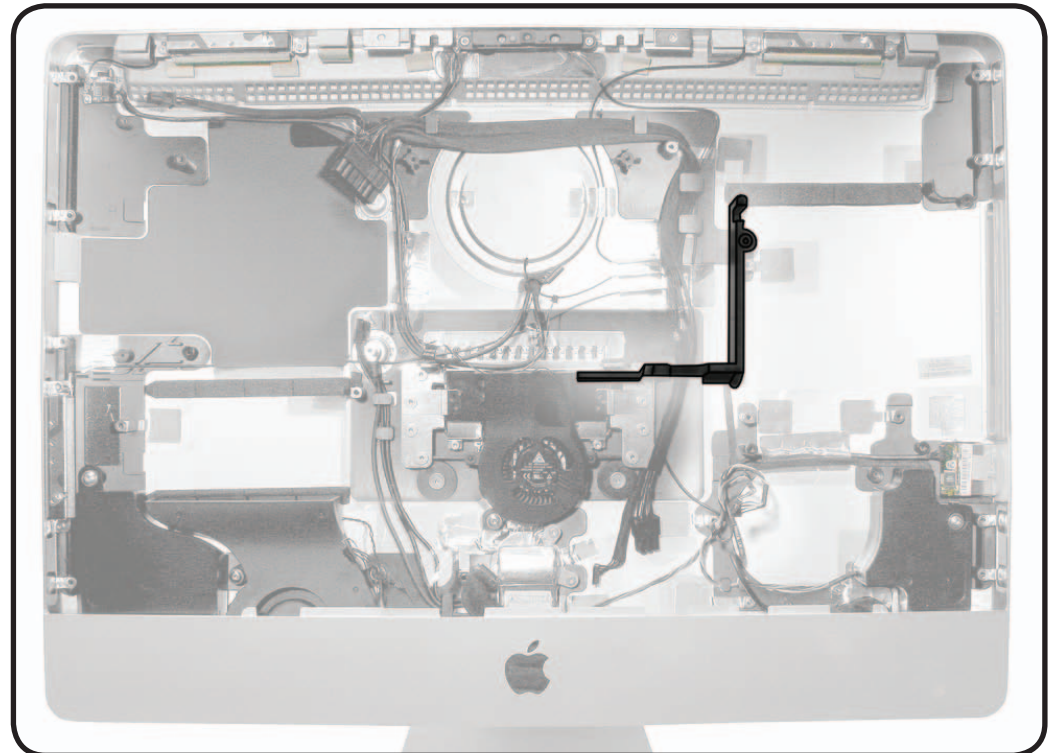

## Tools

- ESD wrist strap





## Removal

- 1 Note the notch in pressure wall for routing of DC power cable and HDD data and power cables.
- 2 Lift pressure wall off posts in rear housing.

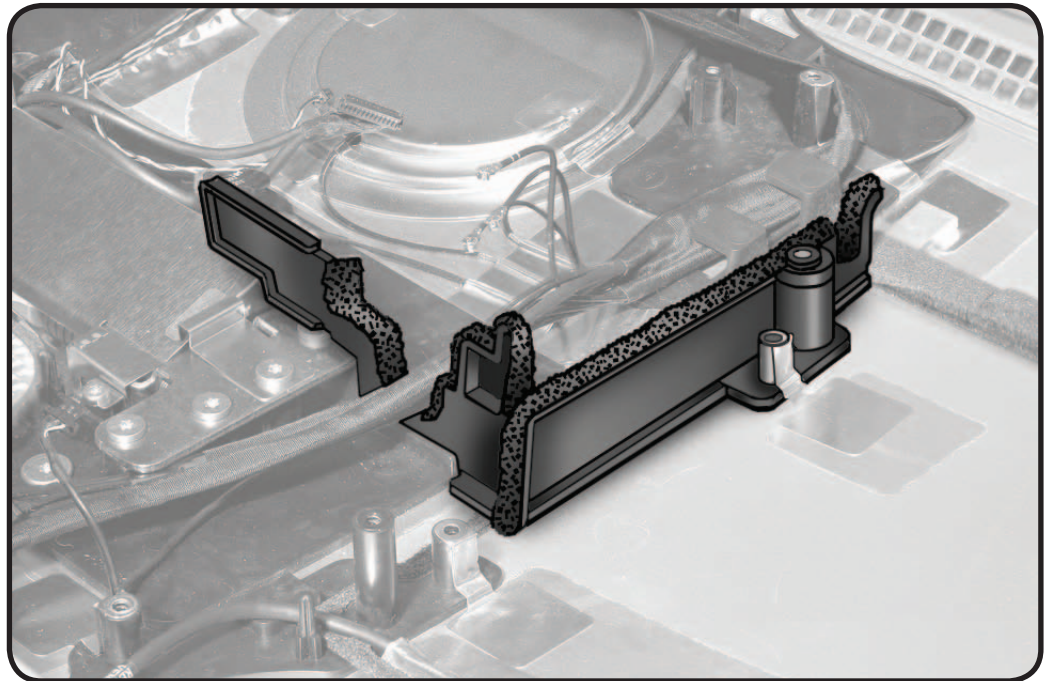



# Hard Drive Fan

## First Steps

Remove:

- Glass Panel
- LCD Panel
- Power Supply
- Backlight Pressure Wall
- Hard Drive (if present in this configuration)
- Power Supply Pressure Wall
- Optical Drive
- Optical Drive Fan
- IR Board
- Logic Board

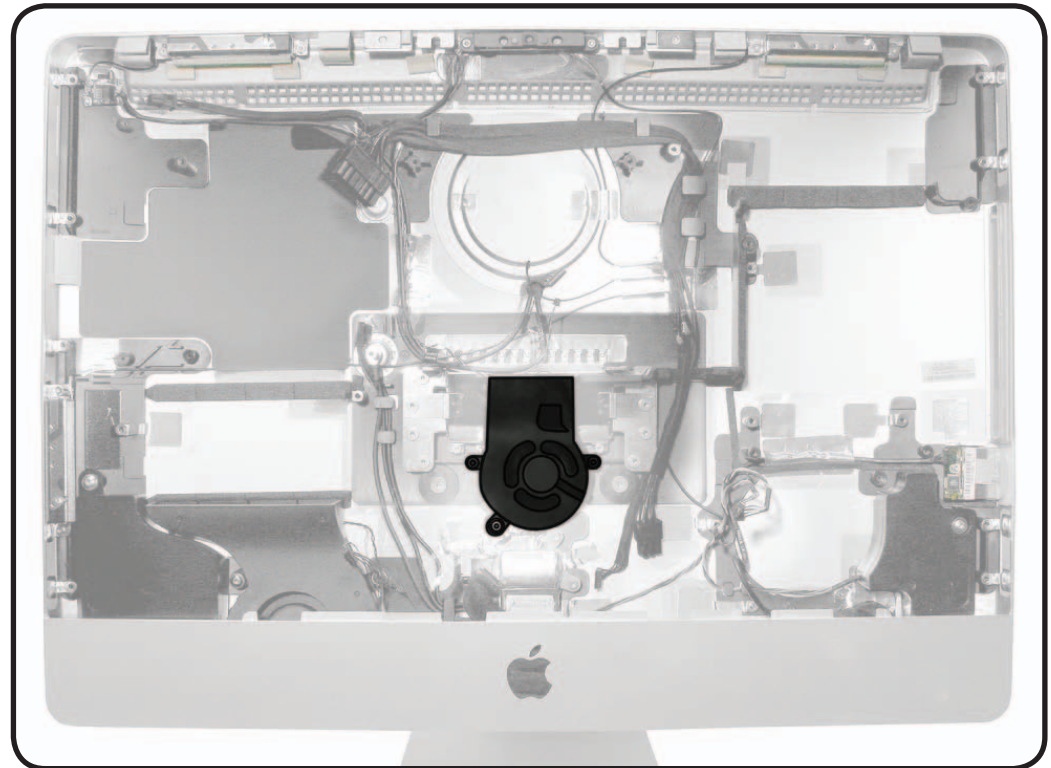

## Tools

- ESD wrist strap
- Torx T10 screwdriver

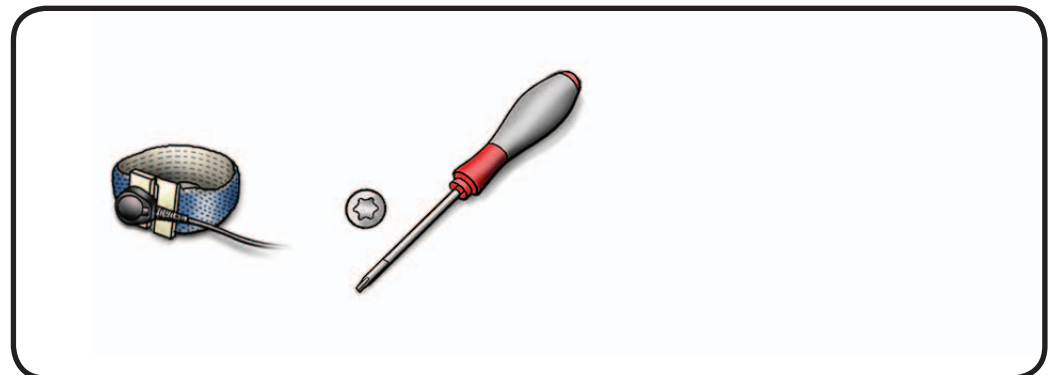



## Removal

- 1 Remove T10 screw:  
(1) 922-9236



- 2 Lift fan straight up  
and off guide posts.

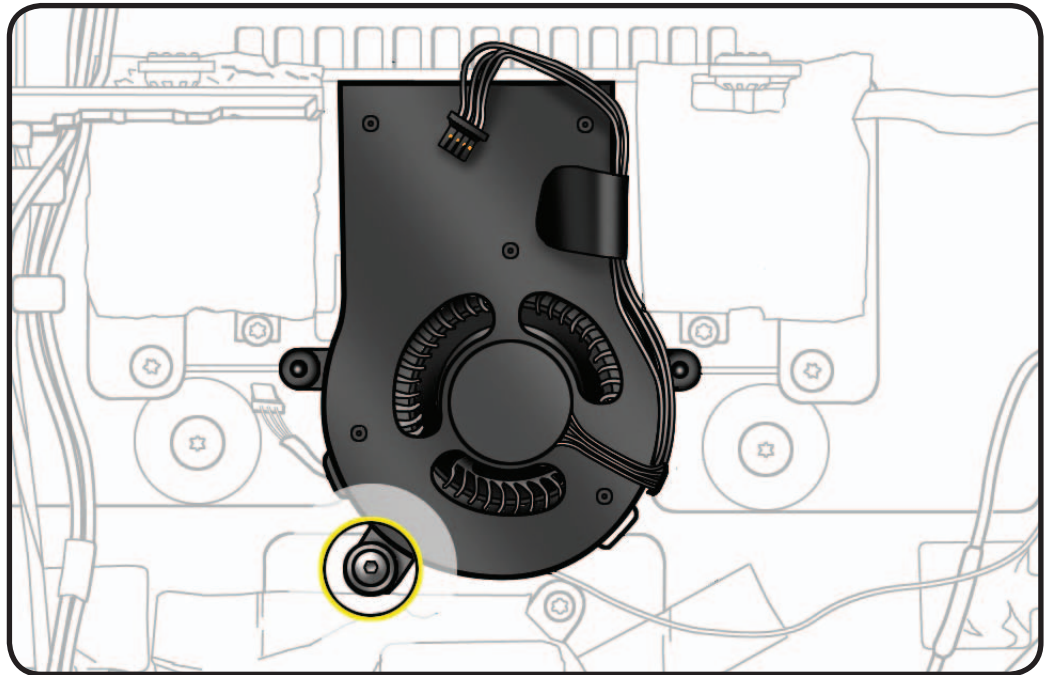

**Reference:** When the logic board is installed, the hard drive fan cable attaches to connector #7 at top center of logic board.

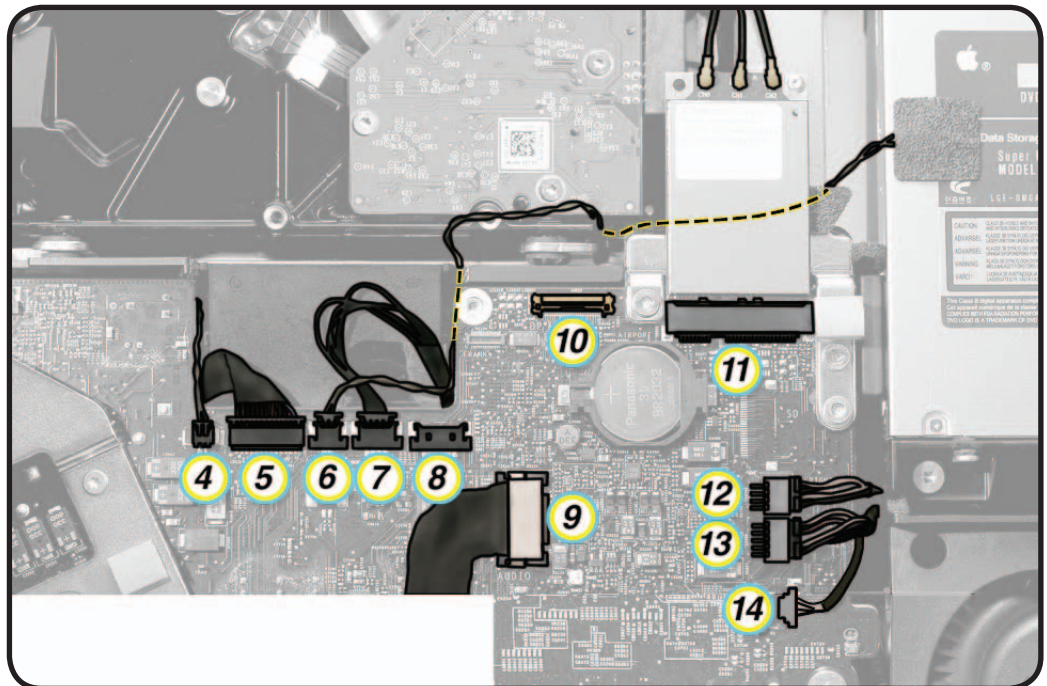



# CPU Fan

## First Steps

Remove:

- Glass Panel
- LCD Panel
- Power Supply
- Backlight Pressure Wall
- Hard Drive (if present in this configuration)
- Power Supply Pressure Wall
- Optical Drive
- Optical Drive Fan
- IR Board
- Logic Board

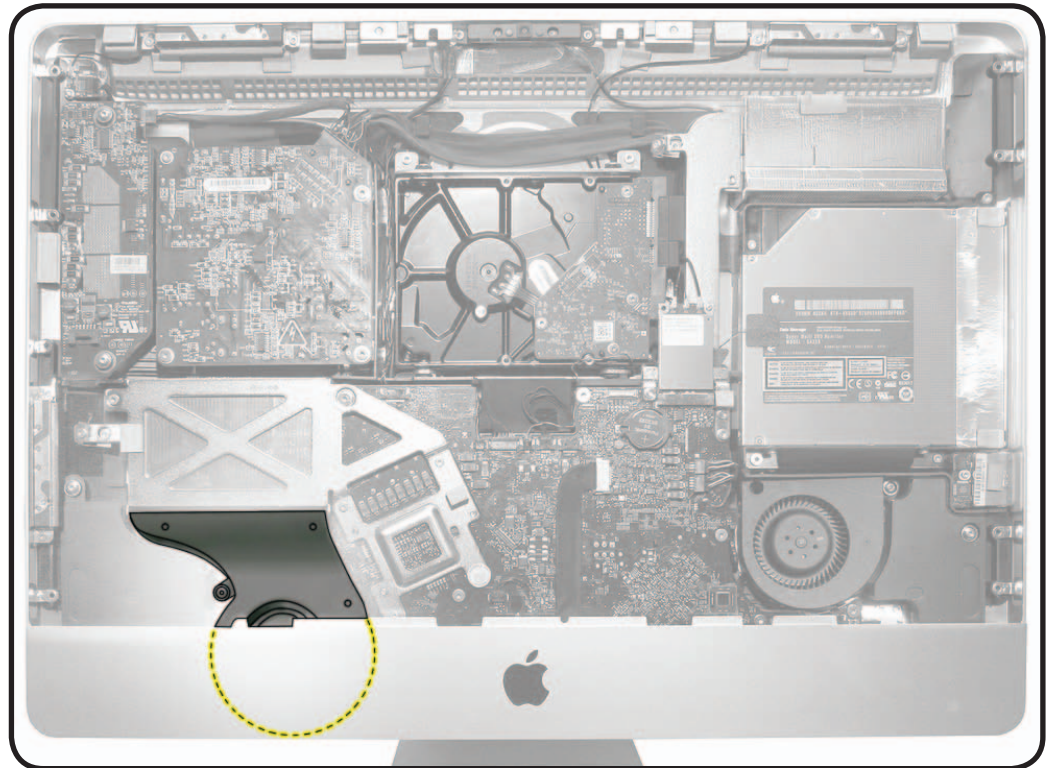

## Tools

- ESD wrist strap
- Torx T10 screwdriver

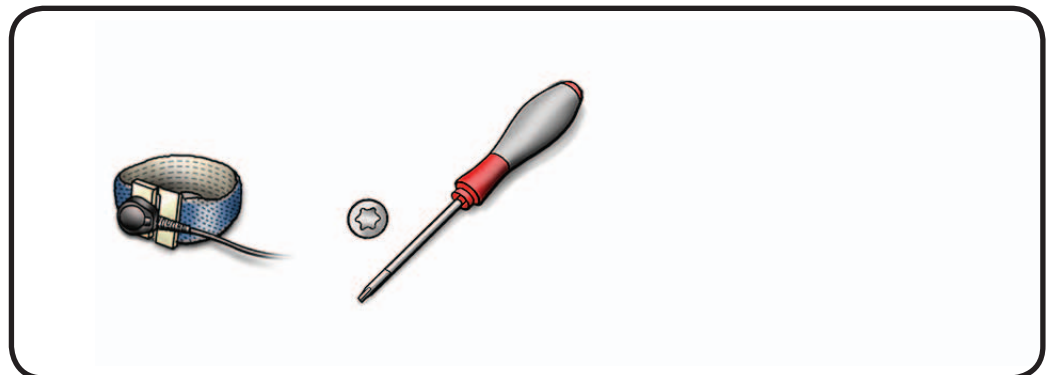



## Removal

- 1 Remove T10 screws:  
(2) 922-9236

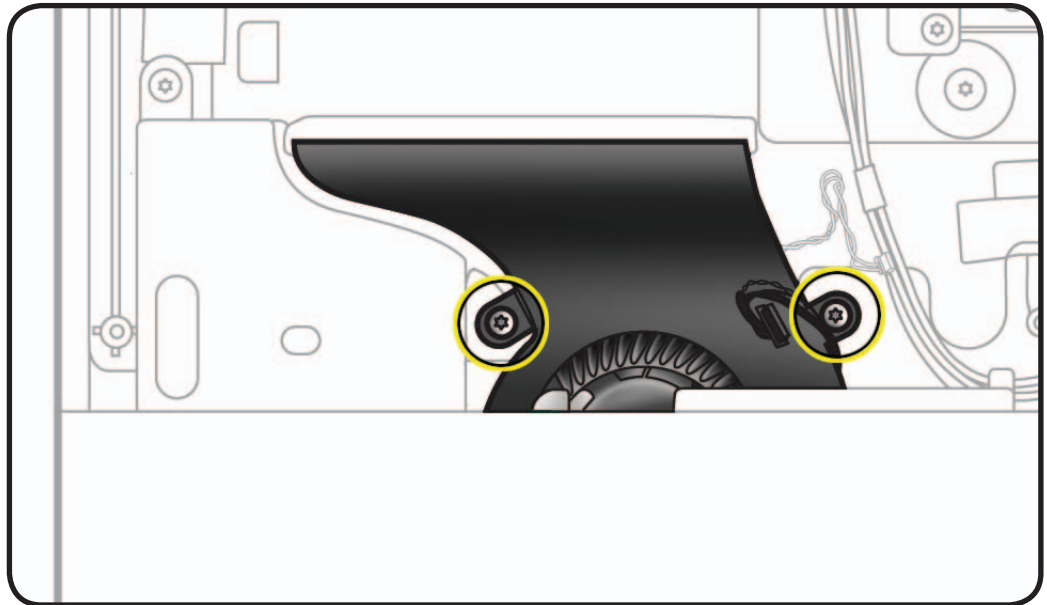

- 2 Lift fan up and out of rear housing.
- 3 Note guidepost on fan that will fit into bottom of rear housing on reassembly.

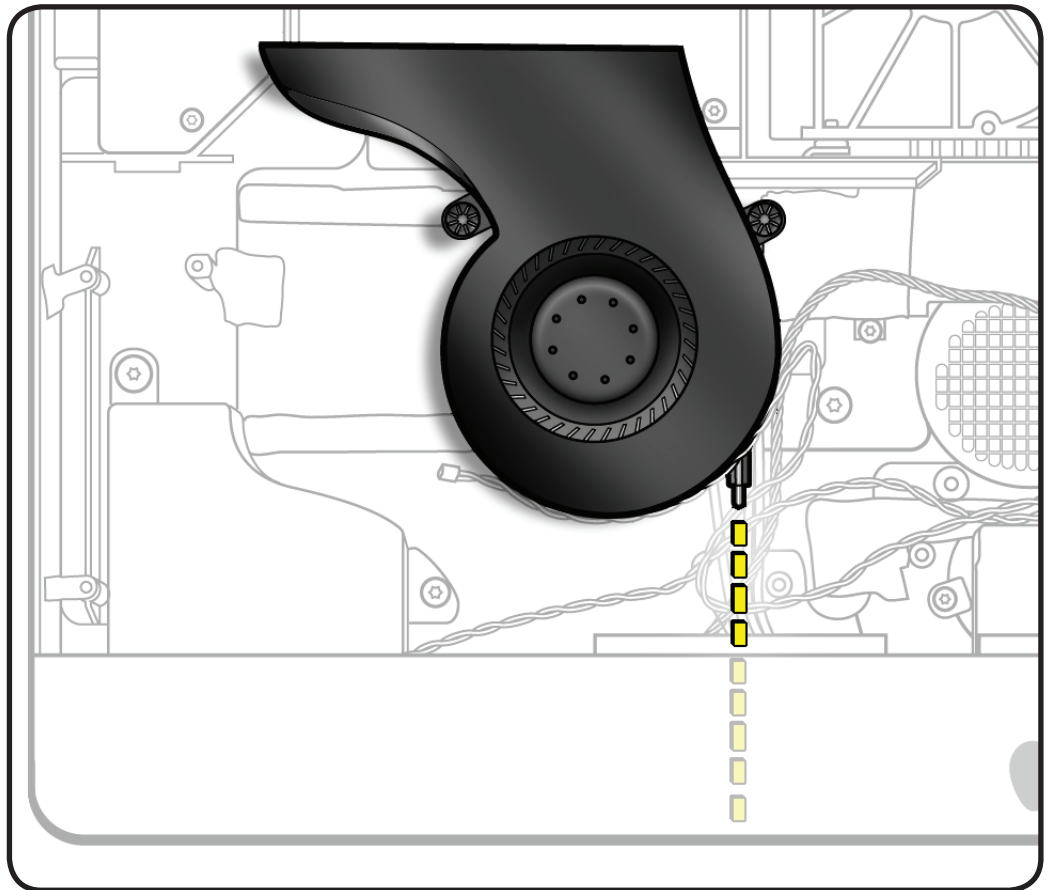



- 4 Note routing of left speaker cable through clip on CPU fan.

The ambient temp sensor cable is integrated with CPU fan and cannot be removed.

- 5 Remove left speaker cable from CPU fan.

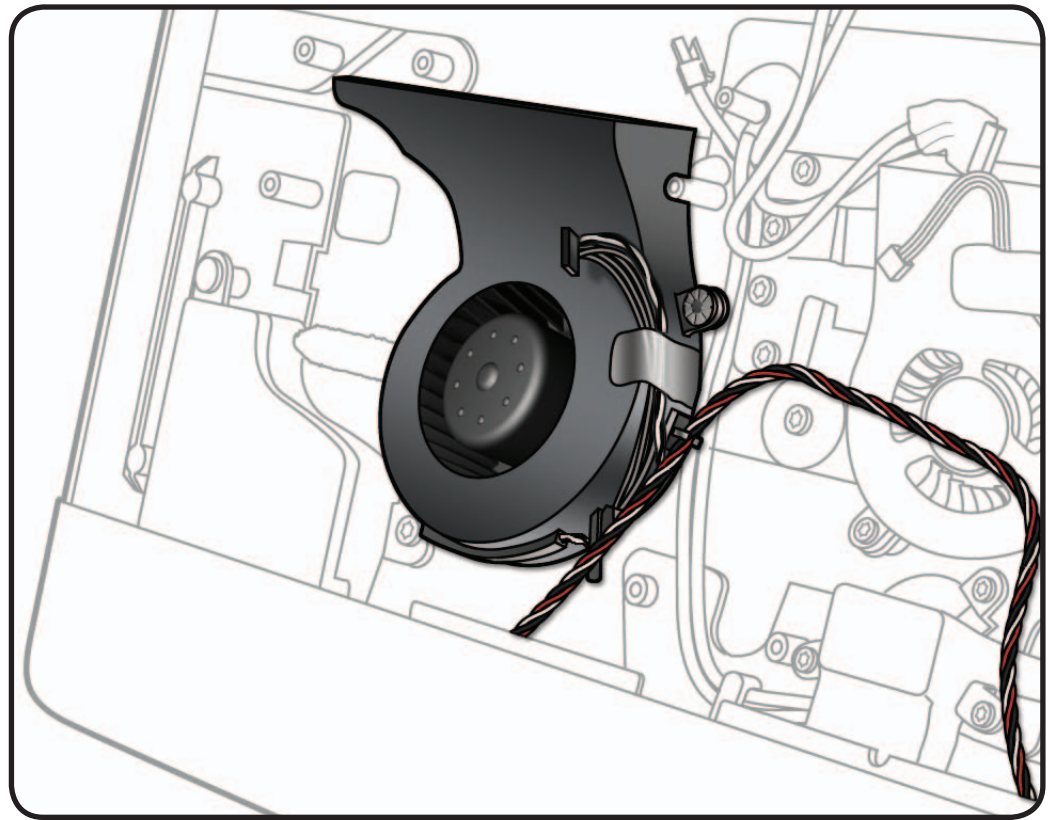



# Left Speaker

## First Steps

Remove:

- Glass Panel
- LCD Panel
- Power Supply
- Backlight Pressure Wall
- Hard Drive (if present in this configuration)
- Power Supply Pressure Wall
- Optical Drive
- Optical Drive Fan
- IR Board
- Logic Board
- CPU Fan

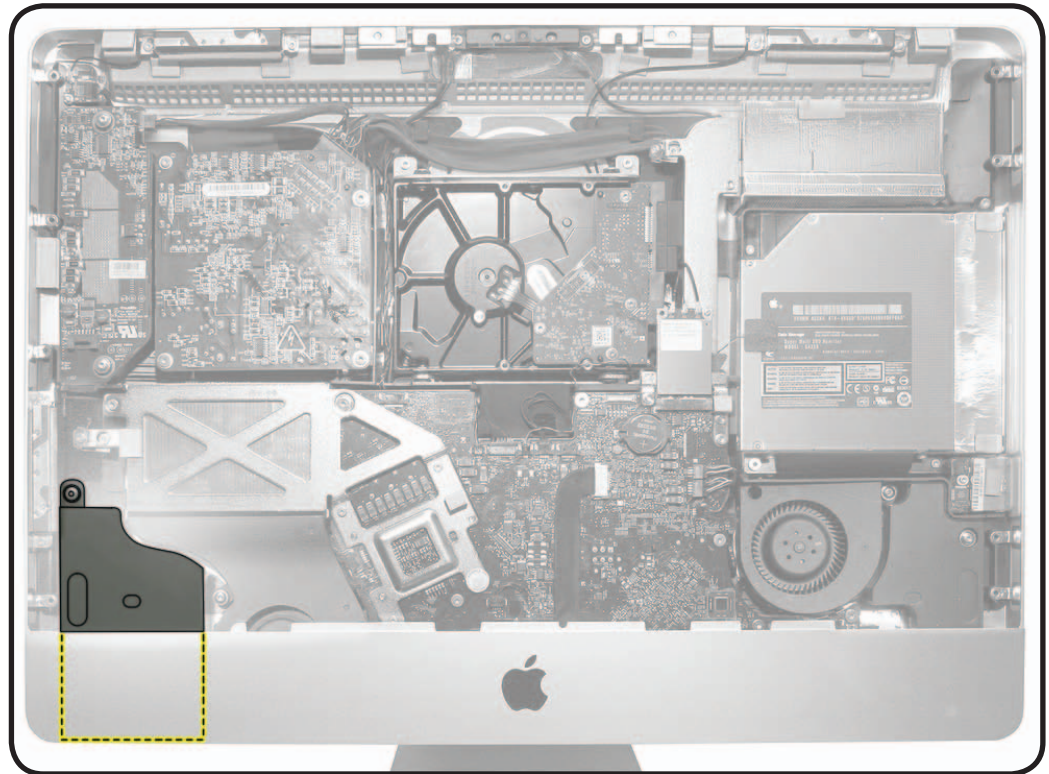

## Tools

- ESD wrist strap
- Torx T10 screwdriver

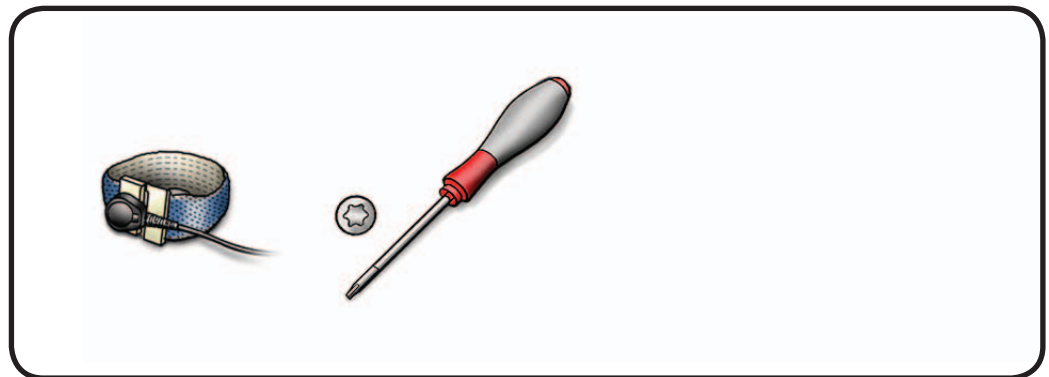



## Removal

- 1 Remove T10 screw:  
(1) 922-9242

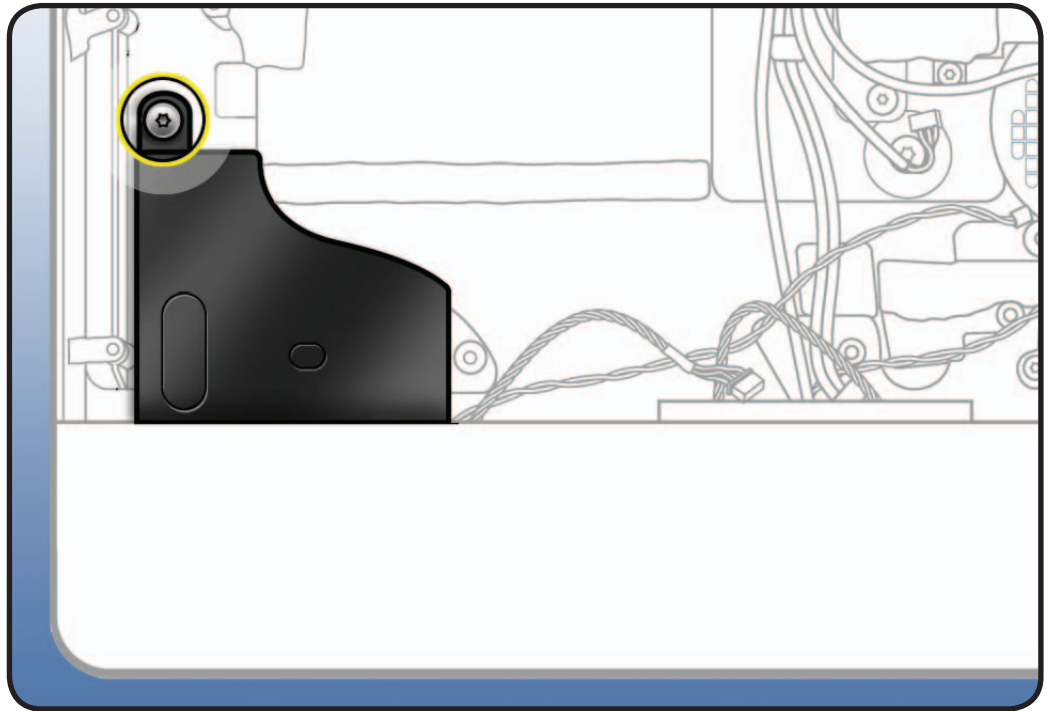

- 2 Remove tape securing cable to rear housing.
- 3 Observe cable routing for reassembly. Refer to photograph in Internal Views section.
- 4 Rotate speaker to the right and lift out of rear housing.

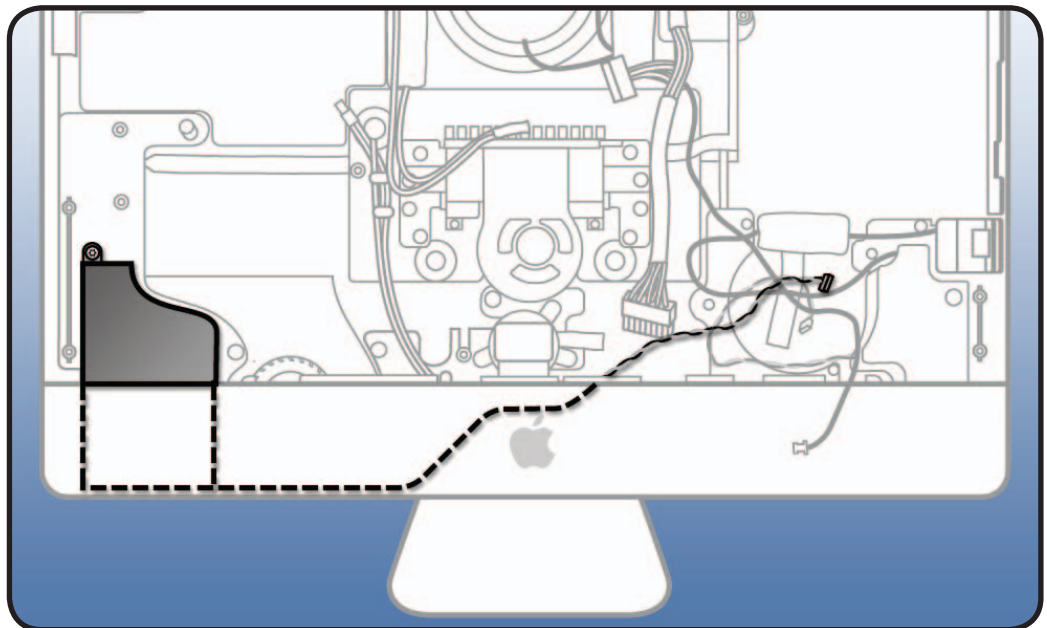



**Reference:** When the logic board is installed, the left speaker cable attaches to connector #13 at top center of logic board.

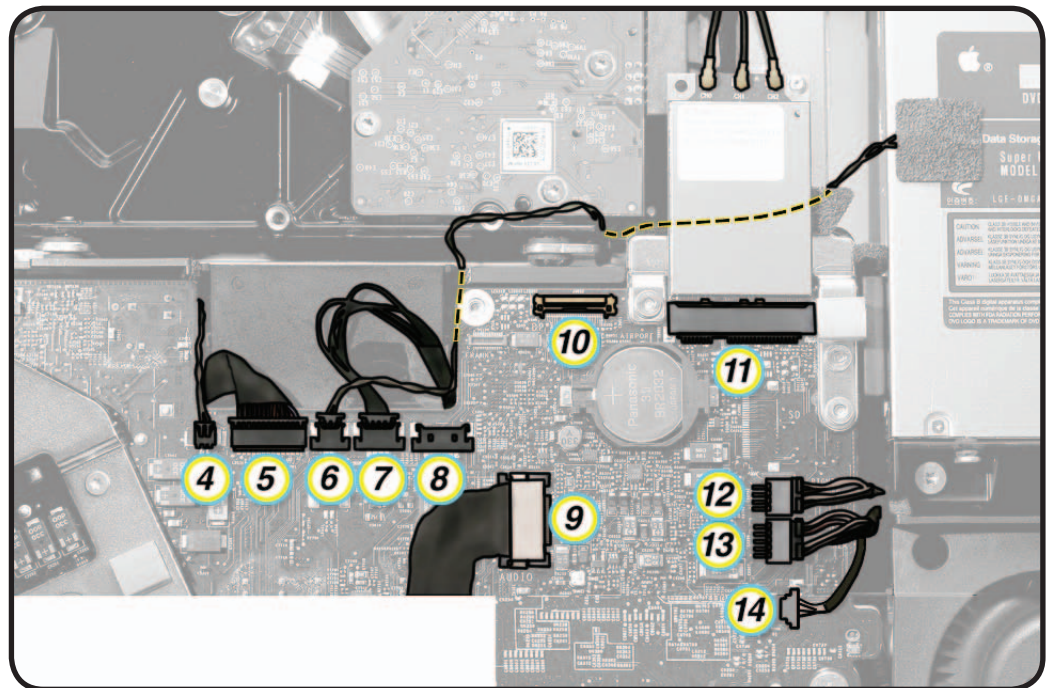



# Right Speaker

## First Steps

Remove:

- Glass Panel
- LCD Panel
- Power Supply
- Backlight Pressure Wall
- Hard Drive (if present in this configuration)
- Power Supply Pressure Wall
- Optical Drive
- Optical Drive Fan
- IR Board
- Logic Board
- Audio Ports & Cable

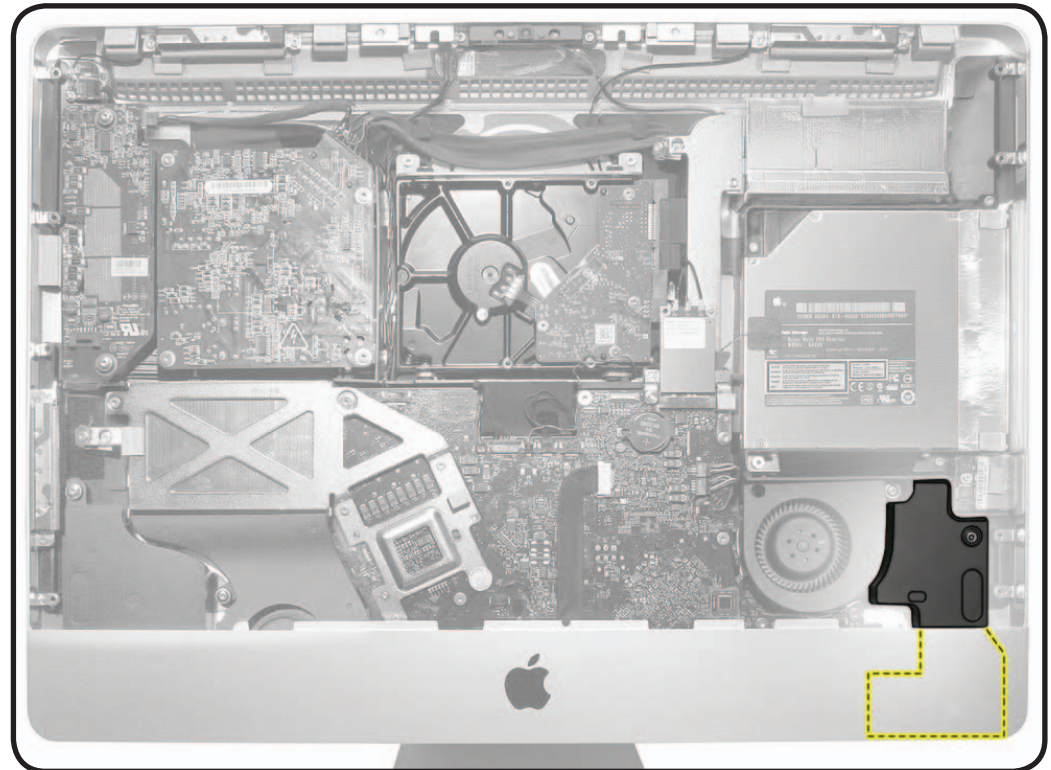

## Tools

- ESD wrist strap
- Torx T10 screwdriver

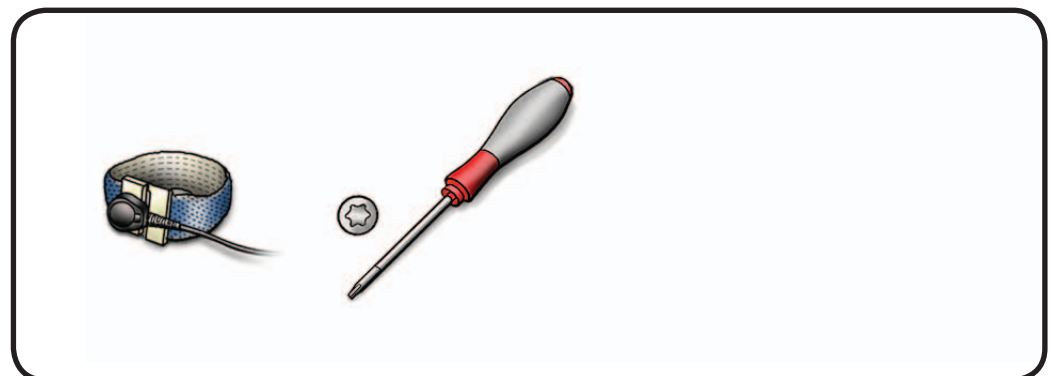



## Removal

- 1 Remove T10 screw:  
(1) 922-9242



- 2 Note cable routing through guide in rear housing.
- 3 Rotate speaker to the left and lift out of rear housing.

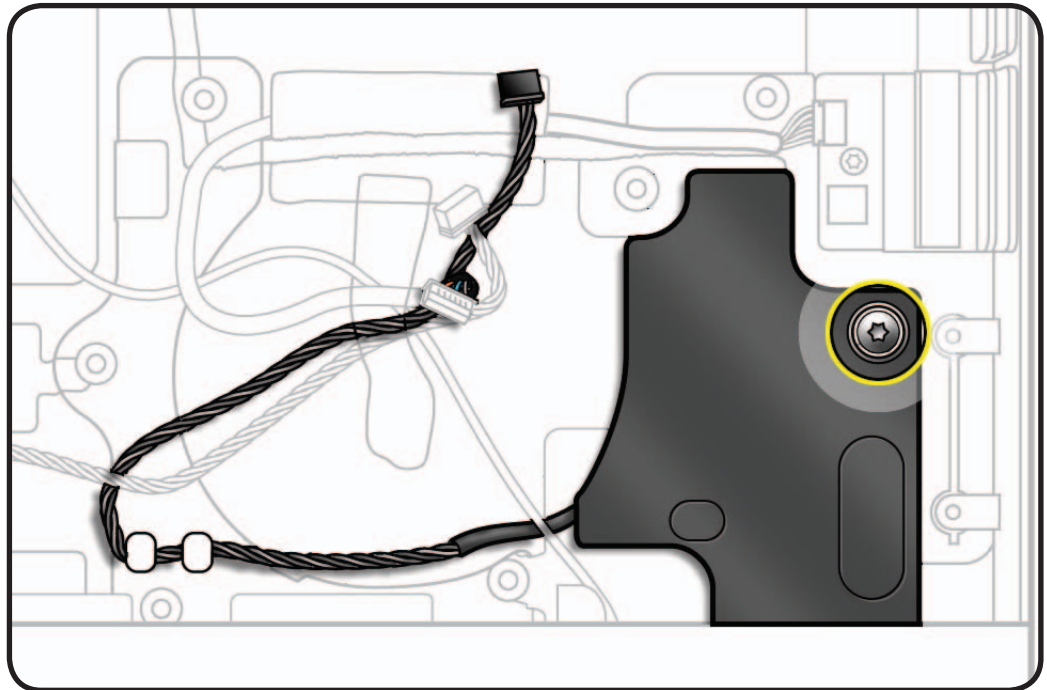

**Reference:** When the logic board is installed, the right speaker cable attaches to connector #12 at top center of logic board.

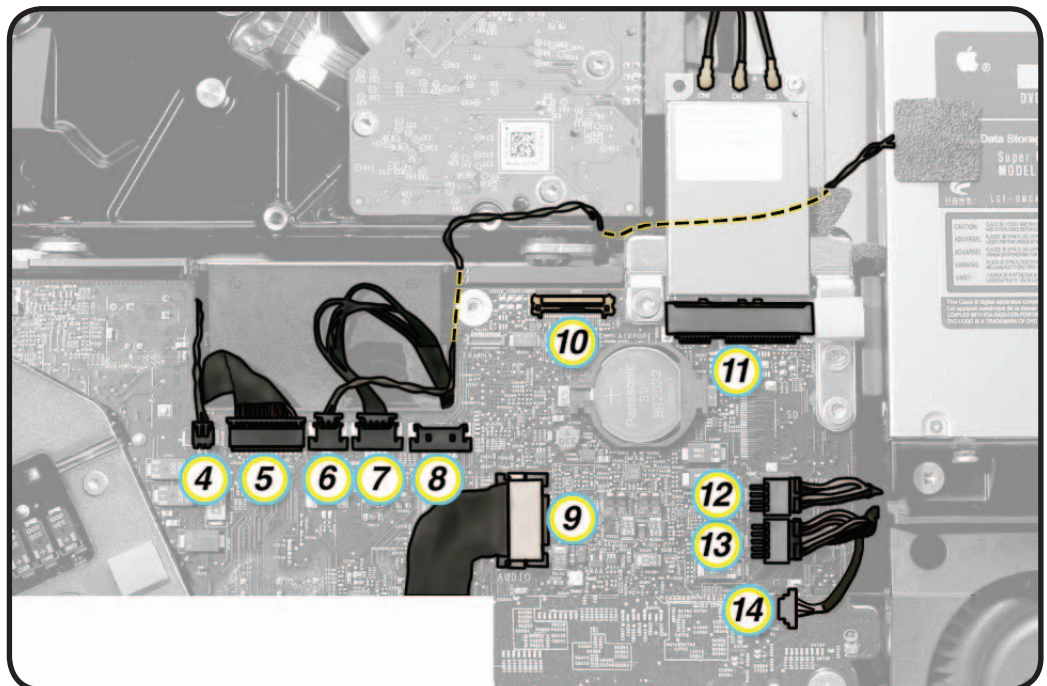



# Mechanism Cover

## First Steps

Remove:

- Glass Panel
- LCD Panel
- Power Supply
- Backlight Pressure Wall
- Hard Drive (if present in this configuration)
- Power Supply Pressure Wall
- Optical Drive
- Optical Drive Fan
- IR Board
- Logic Board
- Hard Drive Fan

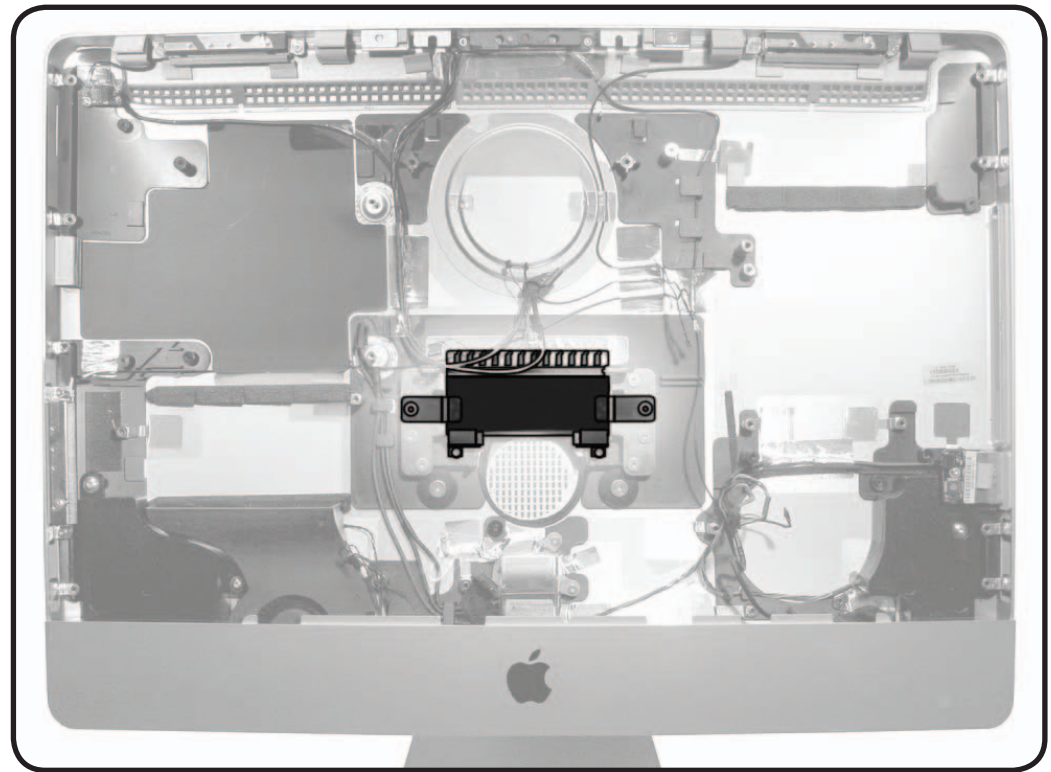

## Tools

- ESD wrist strap
- Torx T10 screwdriver

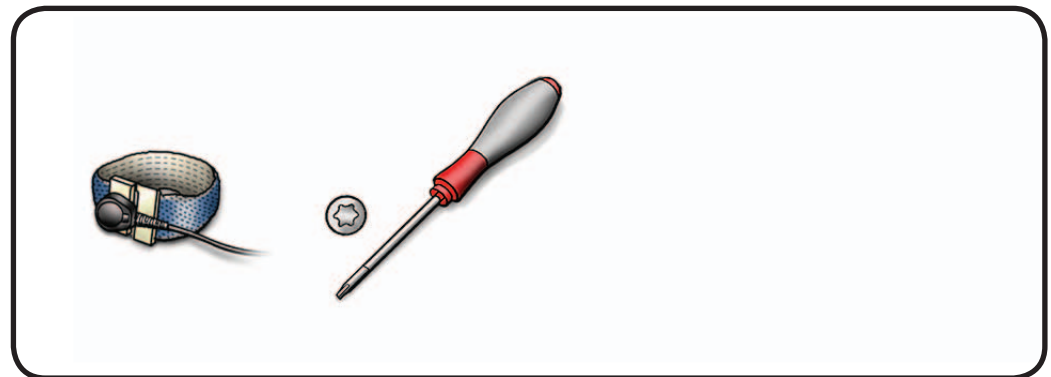



## Removal

### 1 Remove T10 screws:

- (2) 922-9238  
(same screws used on mechanism)



- (2) 922-6800 (smaller screws closer to rear housing vent)

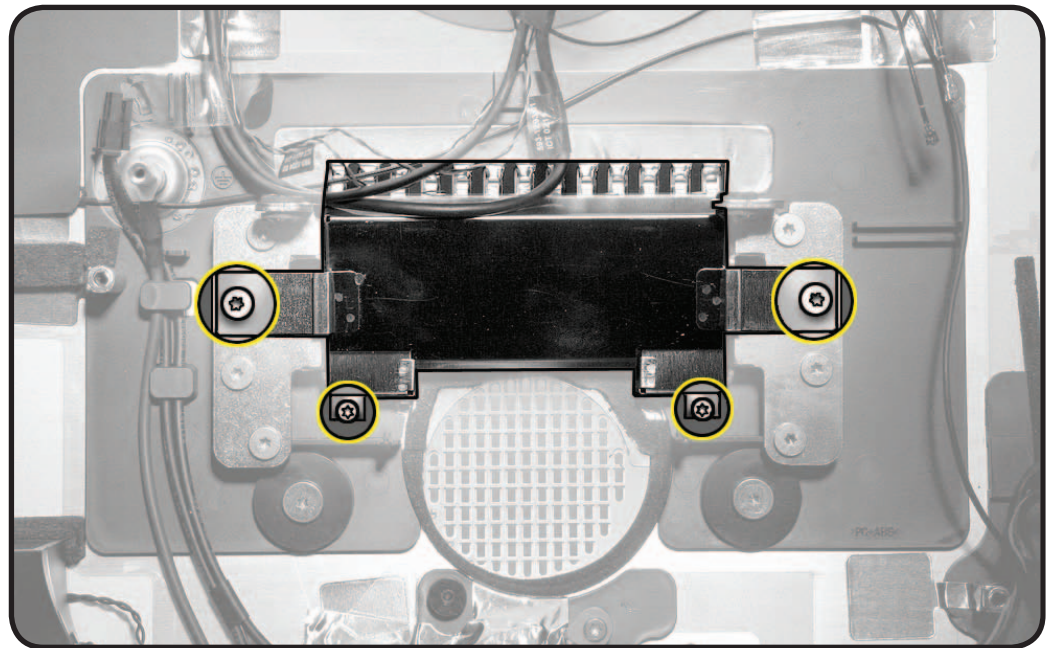



# Stand

## First Steps

Remove:

- Glass Panel
- LCD Panel
- Power Supply
- Backlight Pressure Wall
- Hard Drive (if present in this configuration)
- Power Supply Pressure Wall
- Optical Drive
- Optical Drive Fan
- IR Board
- Logic Board
- Hard Drive Fan
- Mechanism Cover



## Tools

- ESD wrist strap
- Torx T10 screwdriver

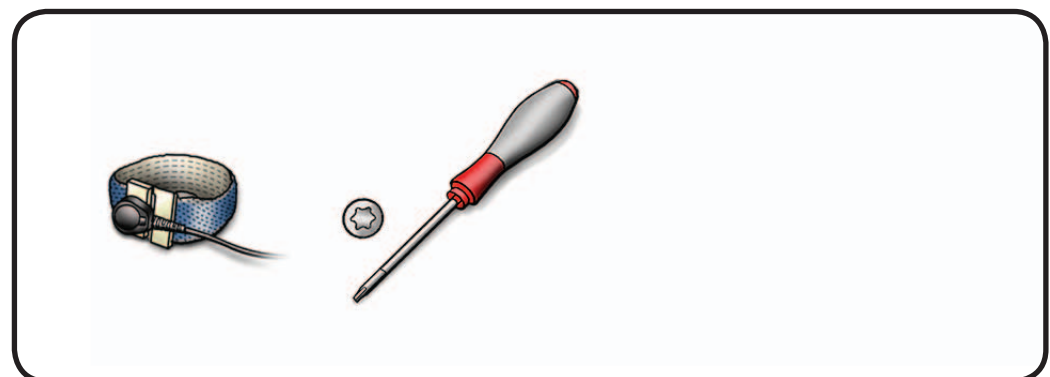



## Removal

- 1 Remove T10 screws:  
(7) 922-8209



### Replacement Note:

Reinstall furthest left and right screws first and then reinstall middle 5 screws.

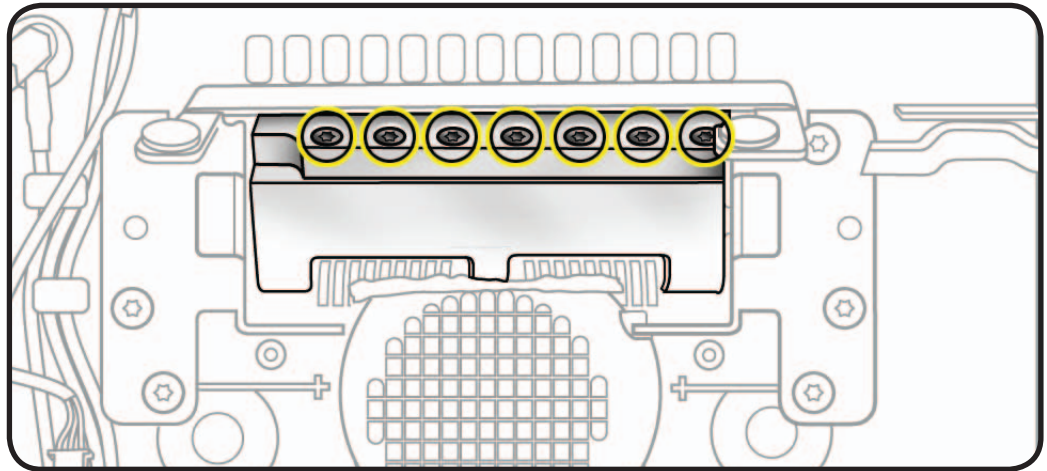

- 2 Lift rear housing off stand.

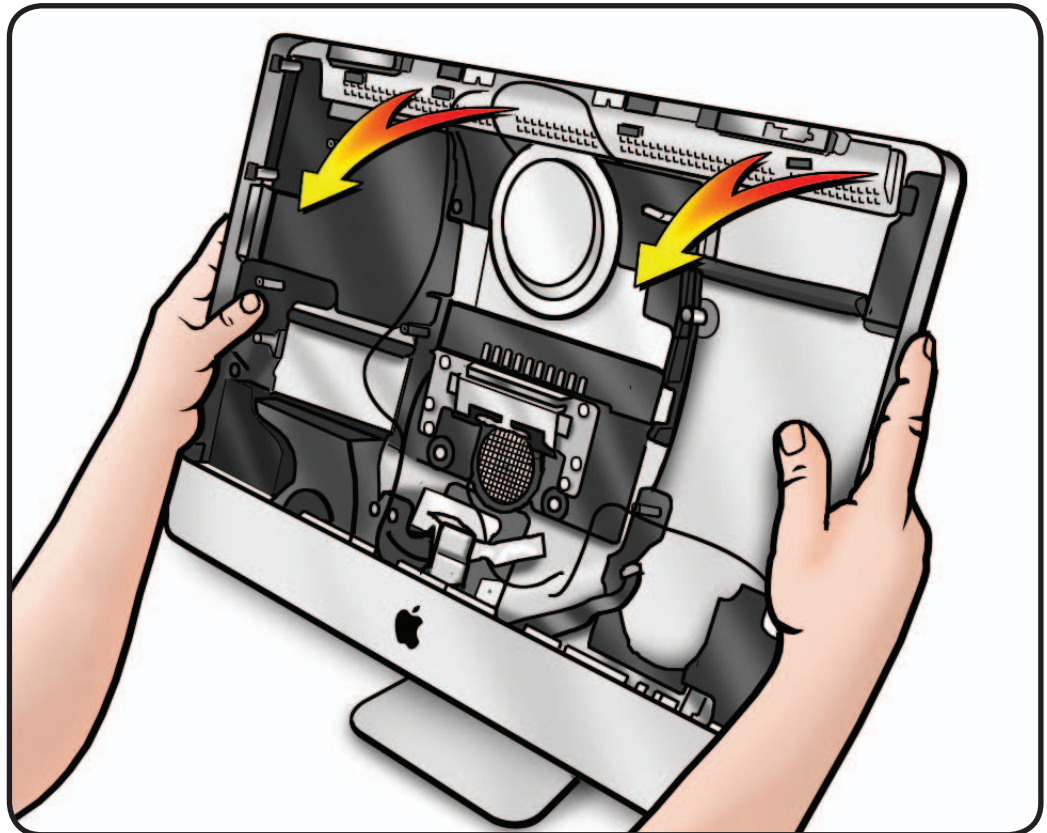



# Mechanism

## First Steps

Remove:

- Glass Panel
- LCD Panel
- Power Supply
- Backlight Pressure Wall
- Hard Drive (if present in this configuration)
- Power Supply Pressure Wall
- Optical Drive
- Optical Drive Fan
- IR Board
- Logic Board
- Hard Drive Fan
- Mechanism Cover
- Stand

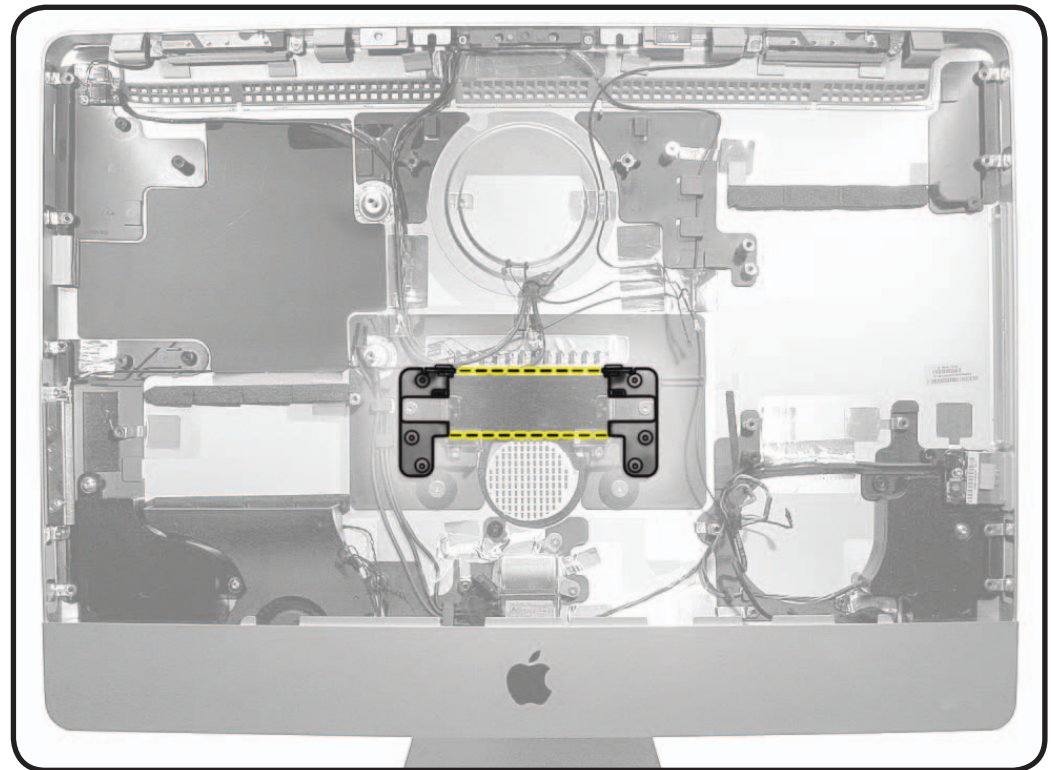

## Tools

- ESD wrist strap
- Torx T10 screwdriver

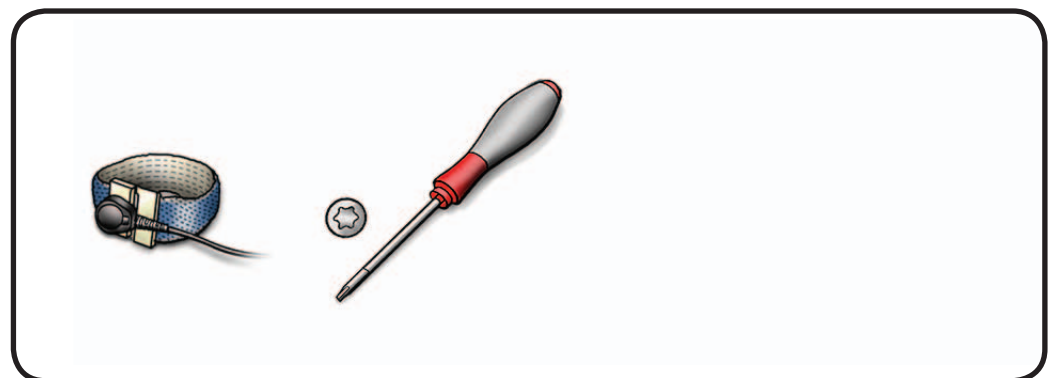



## Removal

- 1 Remove T10 screws:  
(6) 922-9238

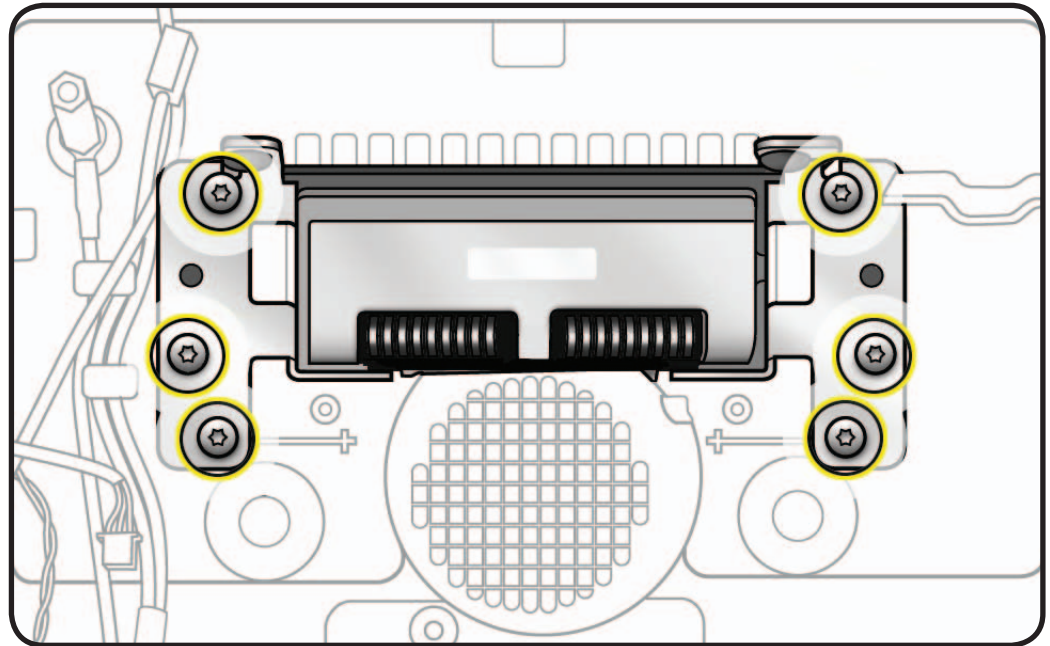



# Rear Housing

## First Steps

Remove:

- Glass Panel
- LCD Panel
- Bluetooth Board
- Bluetooth Antenna
- Camera
- AirPort Antennas (2)
- LED Backlight Board
- Power Supply
- Bluetooth/Camera/Sensor Cable
- Skin Temp Sensor
- Optical Drive
- Hard Drive
- Solid State Drive (CTO option)
- Optical Drive Fan
- IR Board & Cable
- Logic Board
- Audio Ports & Cable
- DC Power Cable
- CPU Fan
- Left Speaker
- Right Speaker
- Pressure Walls (3)
- Hard Drive Fan
- Mechanism Cover
- Stand
- Mechanism

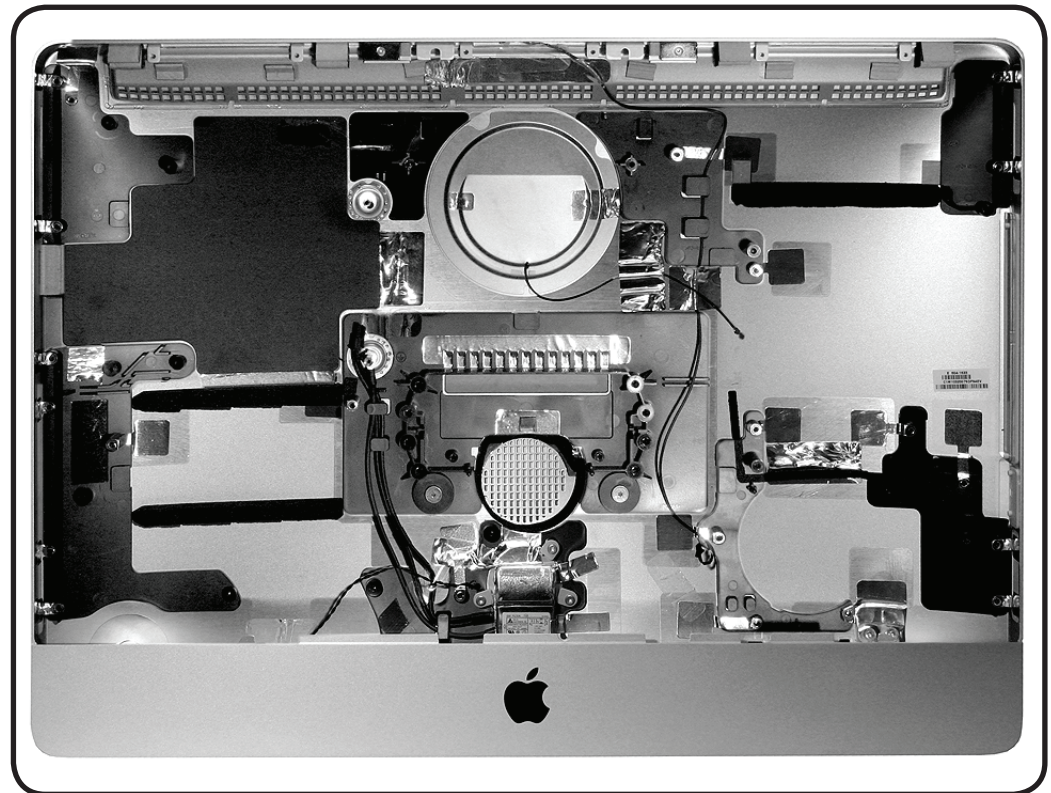

With all other modules removed, rear housing is the remaining assembly.

A new rear housing includes the following parts, which are also available separately:

- SD card reader cable

A new rear housing also includes the following parts, which are NOT available separately:

- AirPort antenna in silver circle behind Apple logo on back of computer
- microphone cable
- power button and cable
- AC inlet
- 4 pieces of foil tape (see next page)



## Handling Rear Housing

**Important:** Handling rear housing part incorrectly could flex aluminum and cause alignment issues.

Always handle rear housing with 2 hands in the lower left and right corners.

Never carry rear housing with a single hand, or by holding the aluminum “chin” (where Apple logo appears on front).

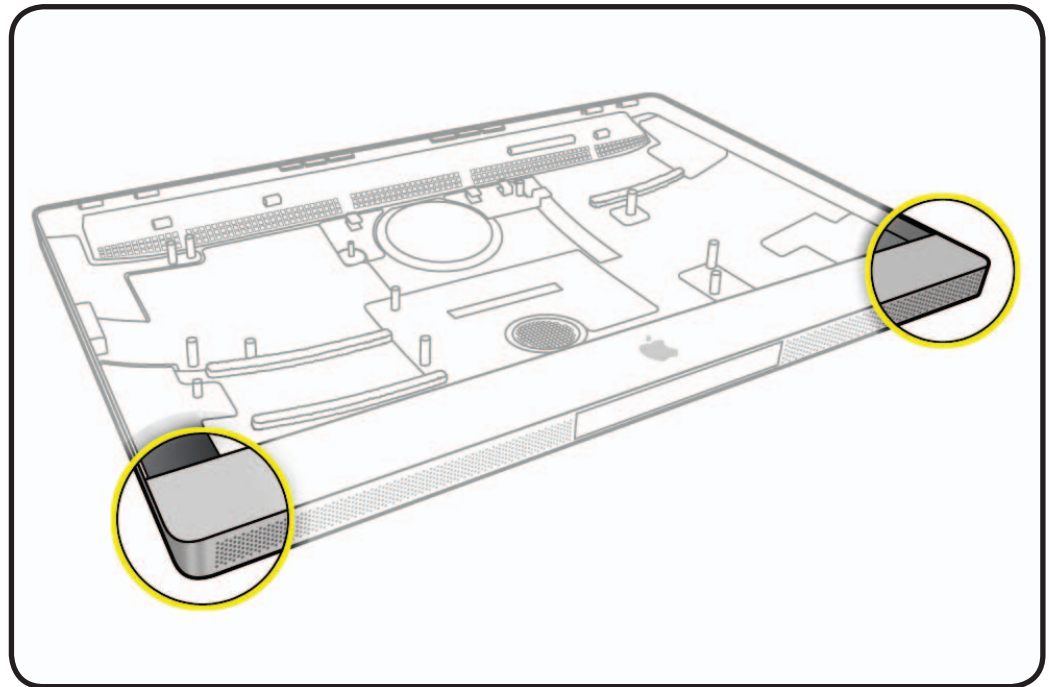

## Replacement Foil Tape

A replacement rear housing includes 4 new pieces of foil tape:

- **Small:** for camera cable near top vent;
- **Medium:** (1) for Bluetooth/camera/sensor cable at top of Apple logo antenna, and (2) for three AirPort antennas to left of AirPort card;
- **Large:** for AirPort antenna, left side, near left edge of rear housing.

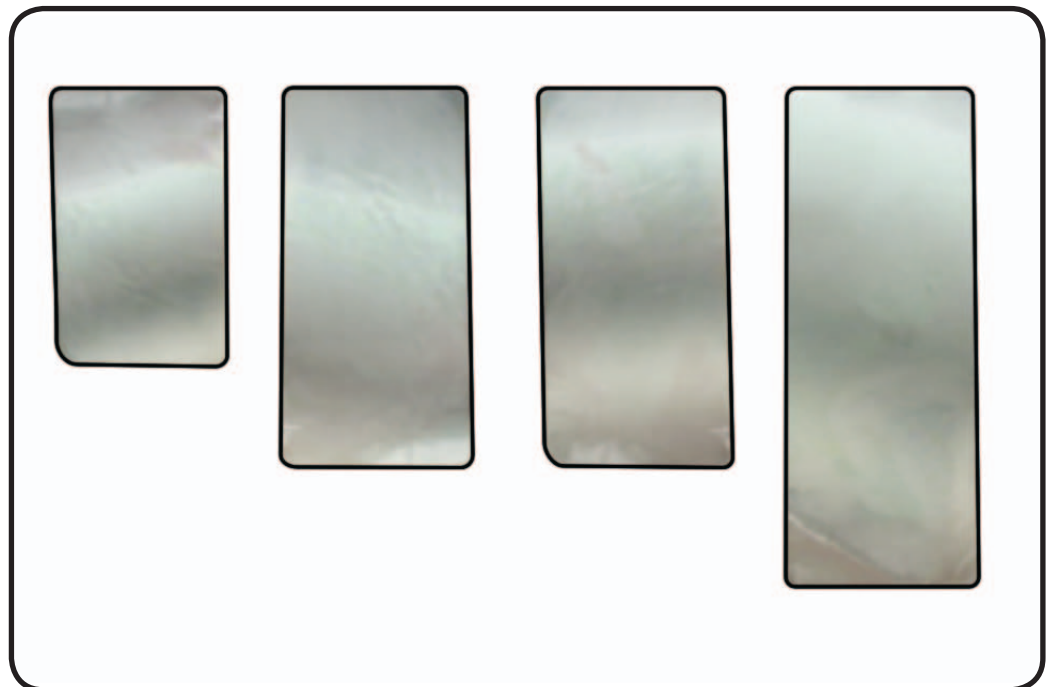



## Camera Thermal Material

Transfer camera from old rear housing to new rear housing and reuse thermal material from old rear housing.

Use a black stick to remove and reapply thermal material to camera (areas circled).

**Note:** A syringe of thermal material is available as needed, Apple part# 922- 9625, good for 5 applications.

**Important:** This white thermal material should NOT be used for any other purpose (such as portable computer heat sinks).

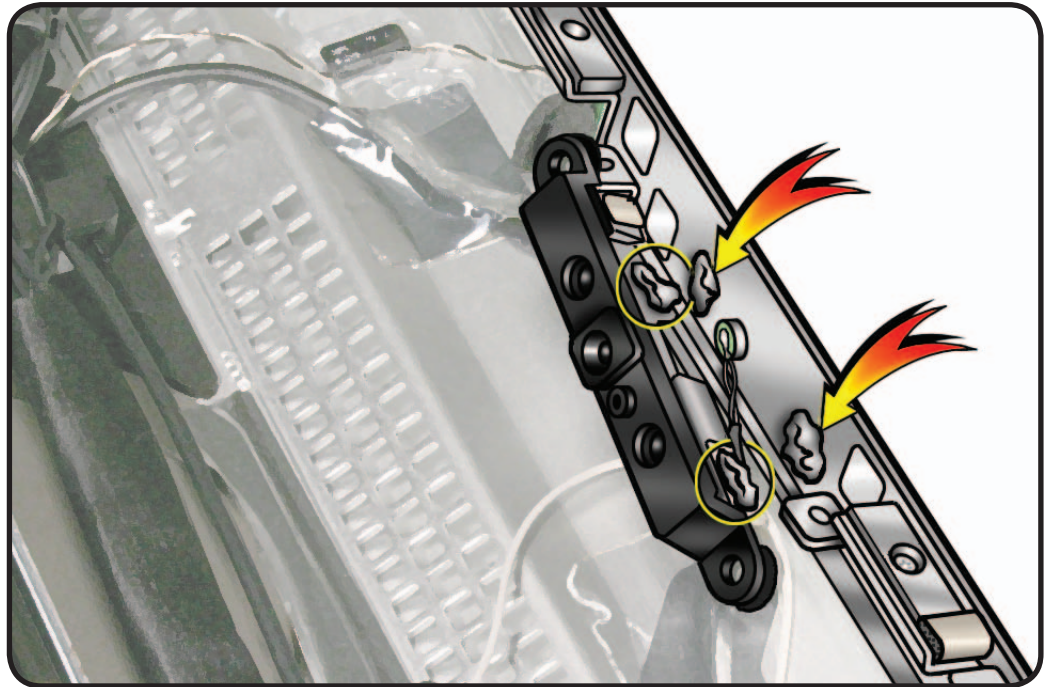

## **Views**

---

### **iMac (21.5-inch, Mid 2011)**



# Exploded Views

## iMac (21.5-inch, Mid 2011), Part 1

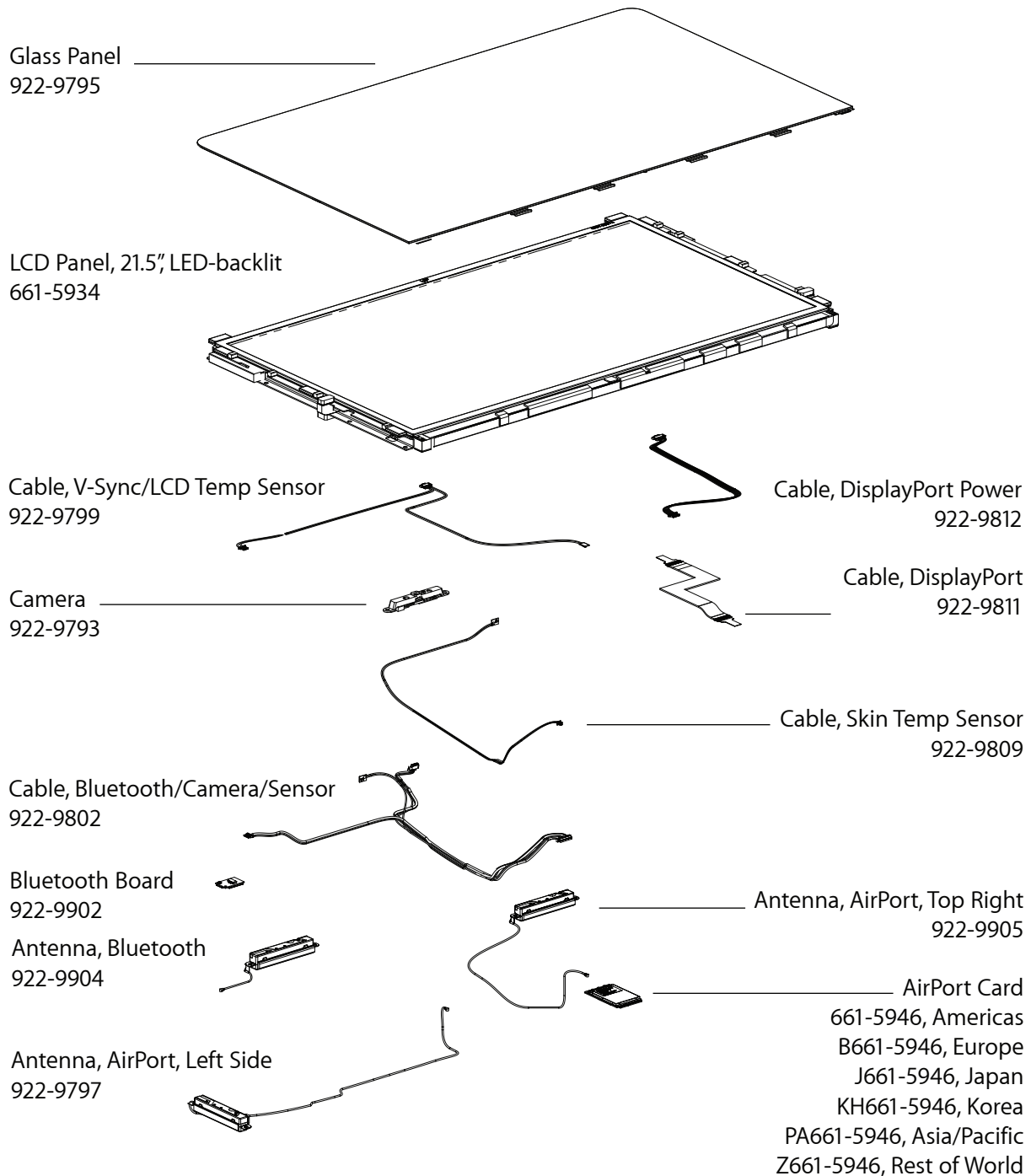



## iMac (21.5-inch, Mid 2011), Part 2

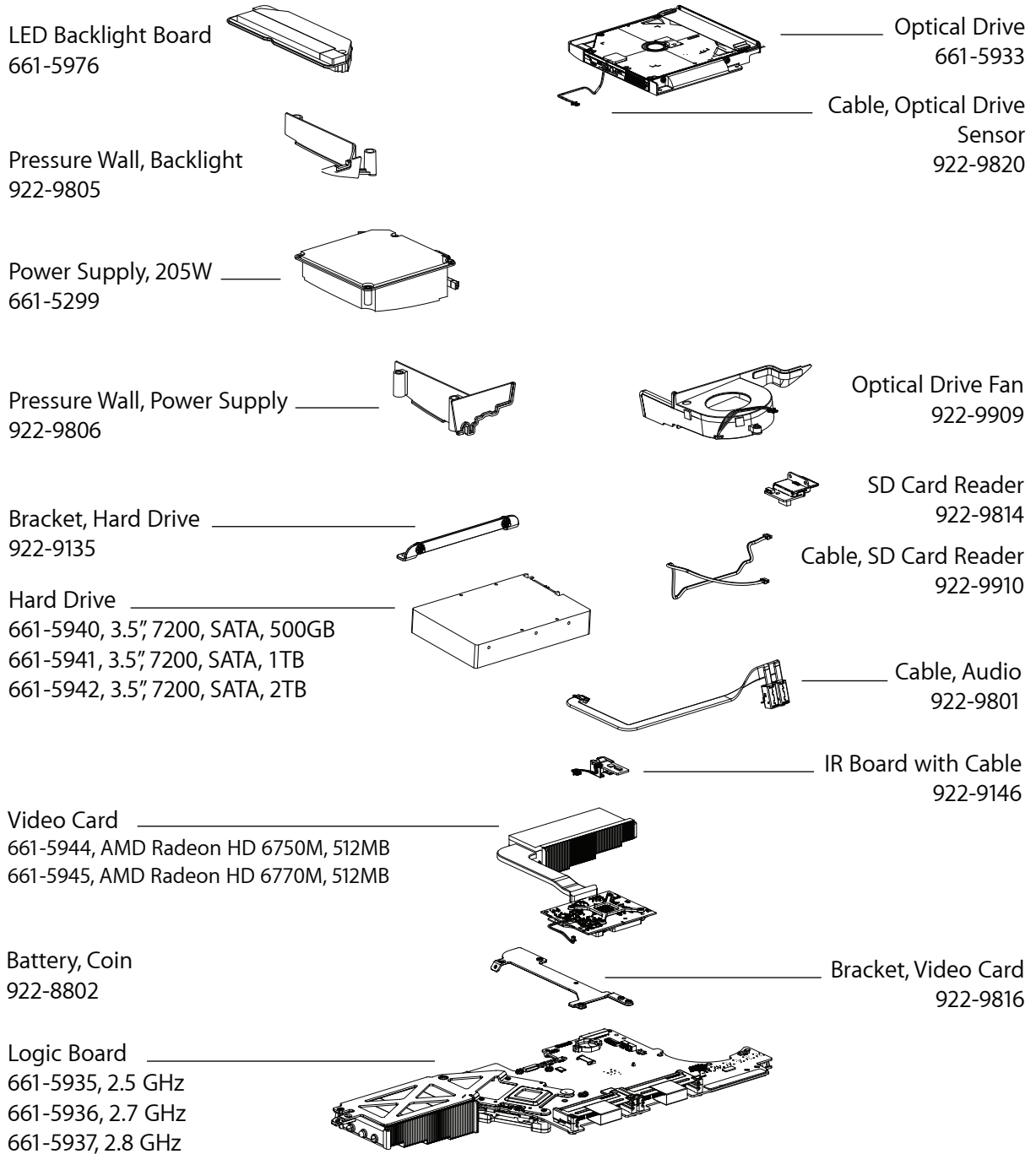





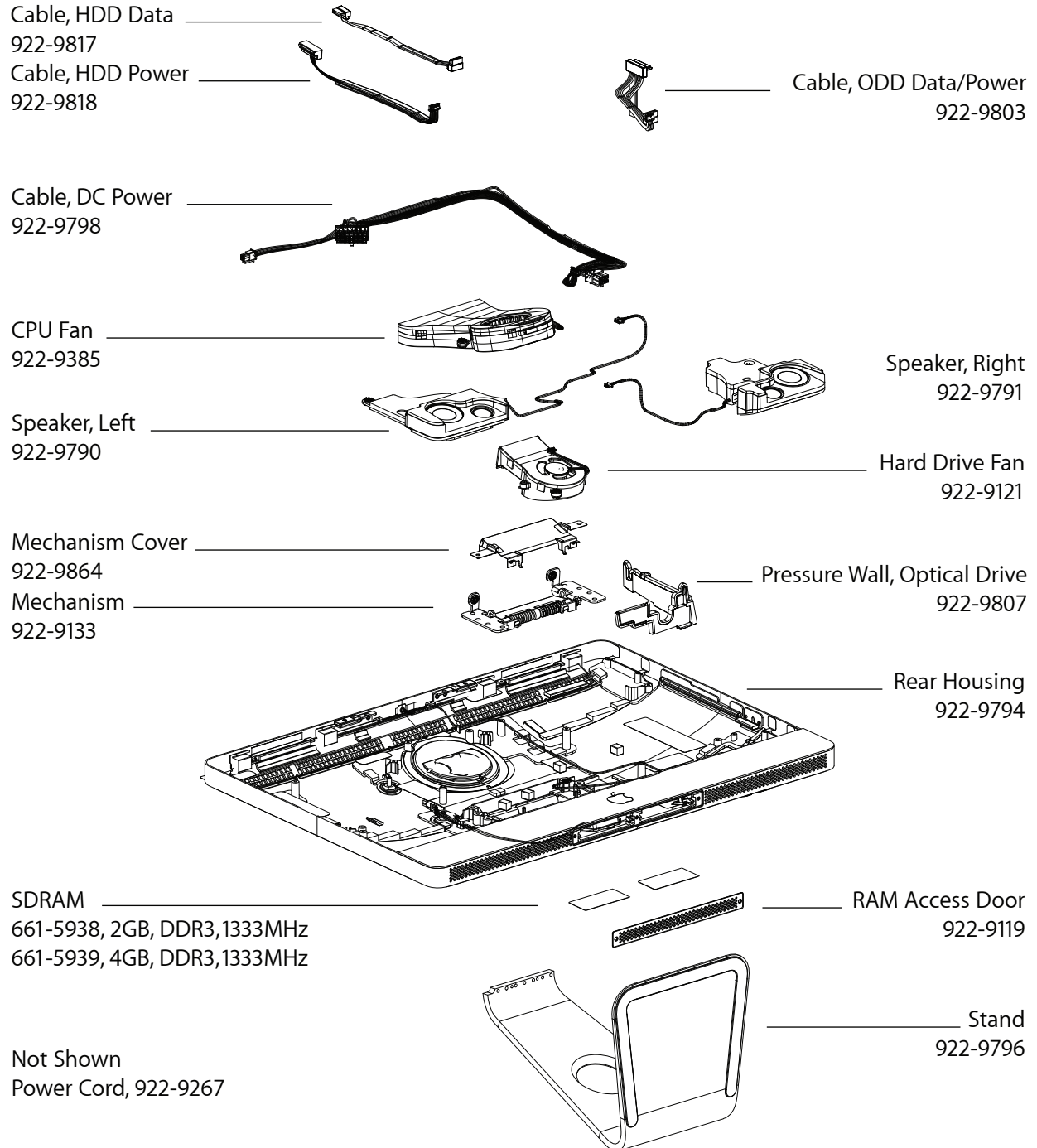









## iMac (21.5-inch, Mid 2011), Part 3















# Screw Chart

**Note:** Screws are not to scale.

<p><b>922-4723</b> T8</p>  <p>Bluetooth antenna (2), AirPort antenna, top right (2), video card (2), video card bracket (3)</p>	<p><b>922-6800</b> T10</p>  <p>logic board, short (2), mechanism cover, small (2)</p>	<p><b>922-6850</b> T10</p>  <p>power supply, top left (1), hard drive (2), optical drive (3)</p>
<p><b>922-7001</b> T8</p>  <p>hard drive pins (2)</p>	<p><b>922-7971</b> T10</p>  <p>video card (1)</p>	<p><b>922-8209</b> T10</p>  <p>stand (7)</p>
<p><b>922-8579</b> T6</p>  <p>AirPort card (1)</p>	<p><b>922-9136</b> T8</p>  <p>hard drive bracket (2)</p>	<p><b>922-9236</b> T10</p>  <p>optical drive fan (1), hard drive fan (1), CPU fan (2)</p>
<p><b>922-9238</b> T10</p>  <p>mechanism cover (2), mechanism (6)</p>	<p><b>922-9239</b> T10</p>  <p>camera (2)</p>	<p><b>922-9241</b> T8</p>  <p>SD card reader (1)</p>



<p><b>922-9242</b> T10</p>  <p>right speaker (1), left speaker (1)</p>	<p><b>922-9244</b> T10</p>  <p>power supply, machine (2)</p>	<p><b>922-9245</b> T10</p>  <p>audio cable (2)</p>
<p><b>922-9246</b> T10</p>  <p>LCD panel (8)</p>	<p><b>922-9247</b> T8</p>  <p>Bluetooth board (1)</p>	<p><b>922-9880</b> T8</p>  <p>AirPort antenna, left side (2)</p>
<p><b>922-9881</b> T10</p>  <p>logic board, extra-long 29mm (1)</p>	<p><b>922-9883</b> T10</p>  <p>logic board, medium 20mm (2)</p>	<p><b>922-9884</b> T10</p>  <p>power supply, bottom left (1), logic board, long 24mm (2)</p>
<p><b>922-9885</b> T10</p>  <p>optical drive, bottom left (1)</p>	<p><b>922-9901</b> T10</p>  <p>LED backlight board (2)</p>	



# External Views

## Front View





## Rear View

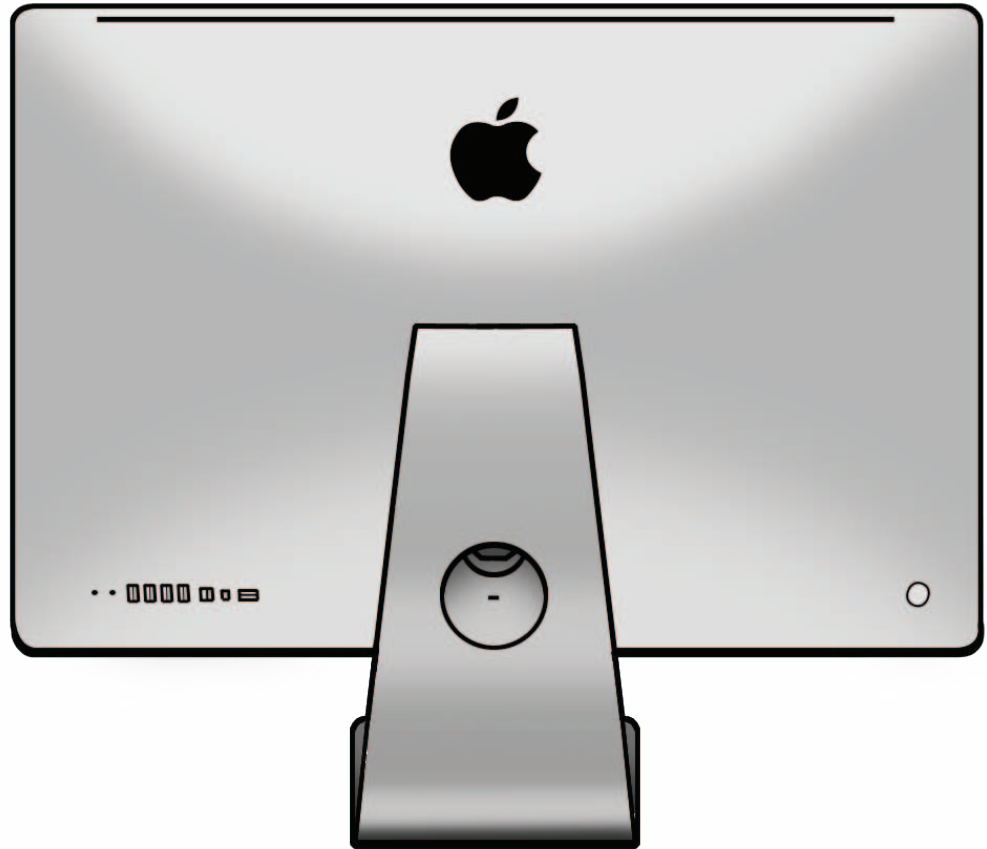



## I/O Ports

1. Headphone-out/optical digital audio-out
2. Audio-in/optical digital audio-in
3. (4) USB 2.0
4. FireWire 800
5. Thunderbolt
6. Gigabit Ethernet

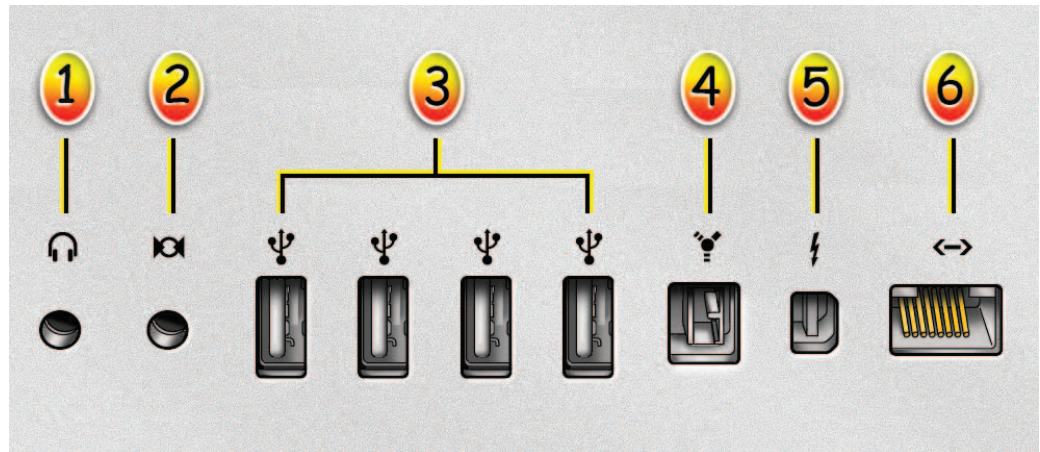



# Internal Views

## Components Below LCD

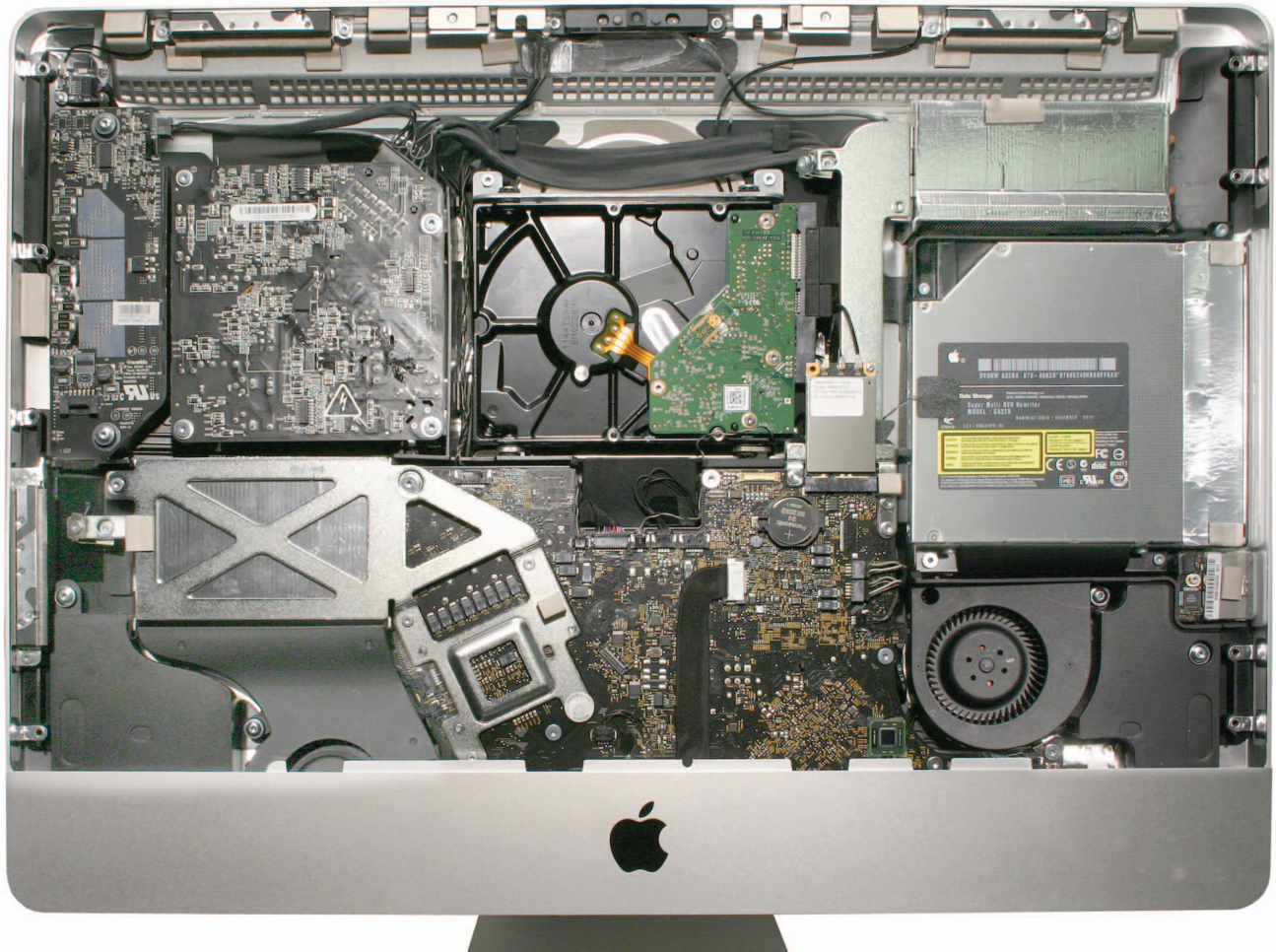



## Components Below Logic Board

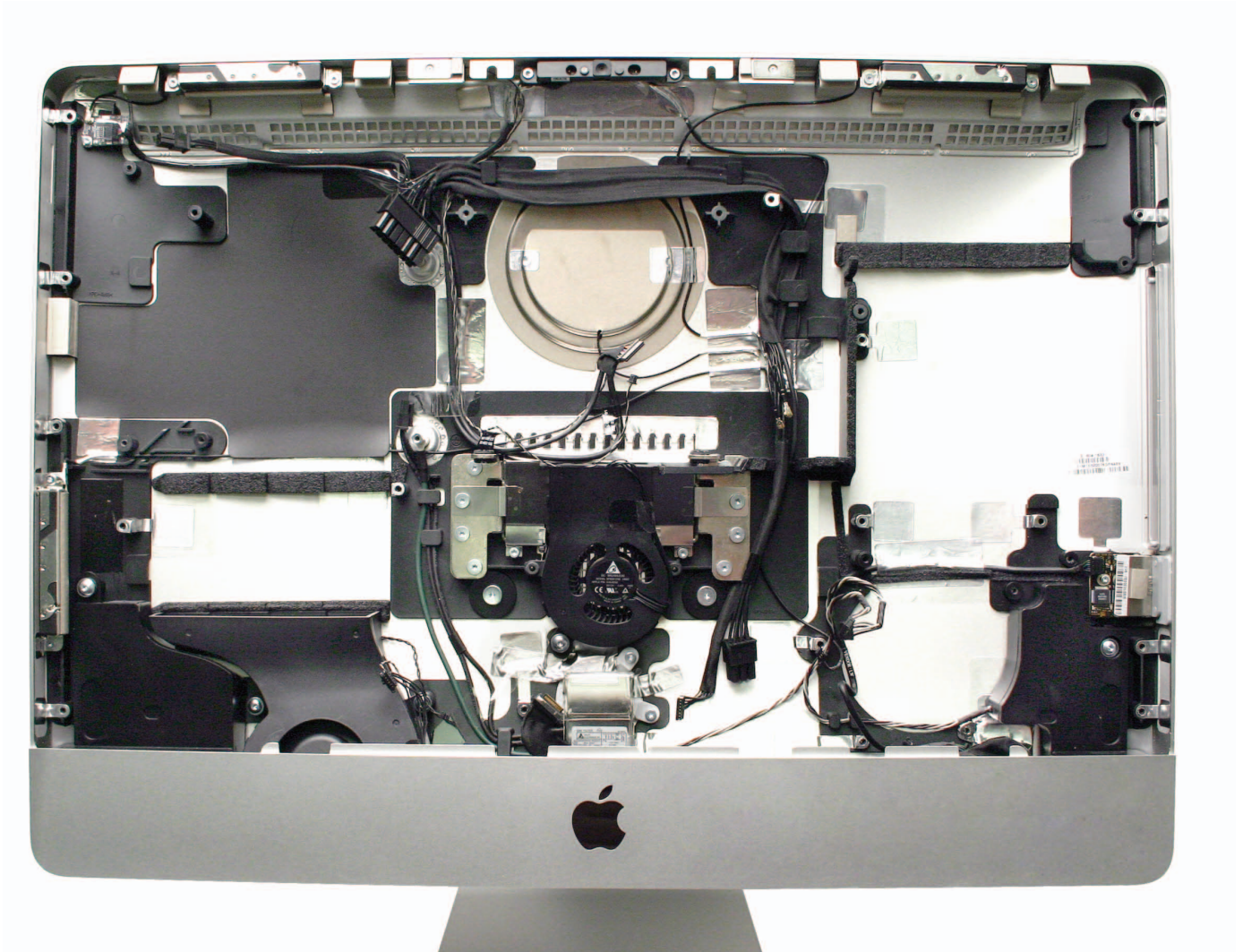



## Logic Board, Front Side

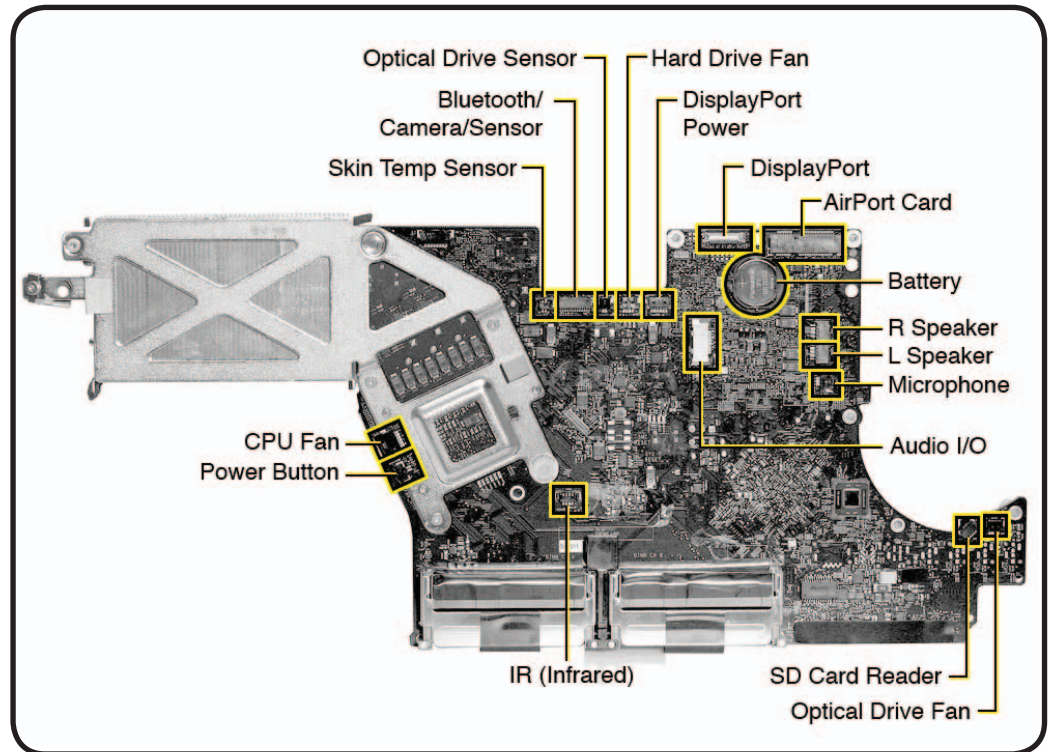

## Logic Board, Back Side

