

UHER

CR 210 stereo

Operating Instructions

Vorwort

Die Kunst zu verwöhnen ist eine Tugend, der sich die Ingenieure der UHER WERKE MÜNCHEN verschrieben haben. In Ihrem UHER CR 210 stereo finden Sie deshalb eine Vielzahl von technischen Feinheiten vereinigt, die äußerlich kaum wahrnehmbar sich in der Funktion erst bemerkbar machen.

Die Leichtgängigkeit der Bedienungselemente erlaubt den Gebrauch des Gerätes auch den zartesten Frauenhänden. Damit wird dieses elektroakustisch hochwertige Cassettengerät als Baustein einer HiFi-Anlage auch gleichzeitig zum Betätigungsfeld der ganzen Familie. Eine genaue Lektüre der nun folgenden Bedienungshinweise wird Sie schnell mit dem Gebrauch Ihres Gerätes vertraut machen.

Preface

The art of pampering is a virtue to which the engineers of the UHER WERKE MÜNCHEN have devoted themselves. In your UHER CR 210 stereo you will therefore discover a multiplicity of technical refinements combined in the recorder, which outwardly hardly perceptible, only make themselves felt in its function.

The smoothness in operation of the controls permits the unit to be operated even by the most delicate of women's hands. In this manner this electro-acoustic high-grade cassette unit becomes, as the module of a hi-fi installation, simultaneously the field of action for the whole family.

Carefully reading the operating hints which follow, will make you quickly familiar with the use of your instrument.





Introduction

La prévenance est une vertu propre aux ingénieurs de la Maison UHER. Le magnétophone à cassette UHER CR 210 stereo comprend une multitude de subtilités techniques qui se remarquent à peine extérieurement, mais font leur apparition au cours du fonctionnement.

Grâce à sa grande aisance de manœuvre, le UHER CR 210 stereo peut être desservi par des mains féminines. Comme magnétophone à cassette doté de hautes performances électroacoustiques, il accompagne la famille dans tous ses déplacements ou s'intègre sans difficulté dans une chaîne HiFi.

La lecture attentive des instructions d'emploi suivantes vous permettra de découvrir et de mettre à profit toutes les possibilités d'application du UHER CR 210 stereo.

Contents

1. Before using your recorder for the first time, please pay attention to the type of power supply	15	Pushbutton  INT. ⑪	19
1.1 Dry cell operation	15	Pushbutton  OFF ⑫	19
1.2 Operating with special type storage battery Z 213 or Z 215	15	4. Playback operation	20
1.3 Operating with the power pack Z 131	16	4.1 Playback via the built-in speaker	20
1.4 Operating on vehicle batteries	16	4.2 Playback via external speaker or earphones	20
1.5 Charging the special types of storage batteries Z 213 or Z 215	17	4.3 Playback via stereo radio receivers or amplifiers	20
2. Connecting sockets	17	4.4 Operating the cassette recorder	20
Socket "□"	17	5. Recording operation	21
"RADIO/PHONO" socket	17	5.1 Operating the recorder during recording	21
"ACCESS" socket	17	6. Further hints	22
Socket "◄"	17	6.1 Remote control via manual remote switch, Type F 112	22
Socket "△"	18	6.2 Recordings with the built-in microphone	23
"AUTORADIO" socket	18	6.3 Mono and stereo microphone recordings	23
3. Controls and their functions	18	6.4 Recording and playback in conjunction with mono radios	24
Controls for injecting and ejecting the cassettes ①	18	6.5 Recording telephone conversations	24
On/off and tape run switch ②	18	6.6 Operating the recorder via the time switch, Type A 403	24
Respooling switch   ③	18	6.7 Using the stereo filter A 311	24
Counter ④	18	6.8 Live sound recording and adding sound to sub-standard films	25
Inspection window ⑤	18	6.9 Erasing without a new recording	25
Control knob VOL. ⑥	19	6.10 Using iron-oxide and chromium-dioxide cassettes	25
Level control and operating voltage indicator ⑦	19	7. Care and maintenance	25
Program indicator ⑧	19	Compact cassettes	25
Pushbutton "Record" ⑨	19		
ALC pushbutton ⑩	19		

1. Before using your recorder for the first time, please pay attention to the type of power supply

The UHER CR 210 stereo can be operated optionally with dry cells, special storage batteries or a power pack. These power supplies can be accommodated in the battery compartment of the unit. To do this, remove the unit from the carrying bag and open the battery compartment. This is accomplished by sliding the latch A in the direction of the arrow. (See Fig. 1).

In addition the power supply can be obtained from the car supply system of a 12 V vehicle battery.

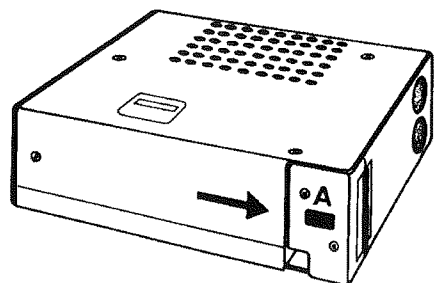

Fig. 1

1.1 Dry cell operation

Six dry cells (penlite cells IECR 14) of 1.5 V are required. All conventional types of dry batteries can be used. Heavy-duty cells should always be given preference. Worn-out cells must be removed immediately, in order to prevent the power supply contacts in the battery compartment from being damaged. The batteries are inserted as shown in the illustration glued into the battery compartment. (See Fig. 2).

1.2 Operating with special type storage battery Z 213 or Z 215

Storage batteries, Types Z 213 and Z 215 are available as rechargeable power sources. When inserting these, care must be taken that

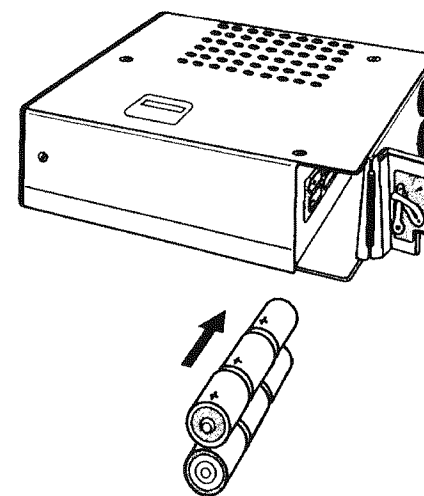

Fig. 2

the storage battery is inserted with the contacts head first and in such a manner that the bevelled edge points towards the top left-hand corner. (See Fig. 3). The storage battery must slide smoothly into the battery compartment.

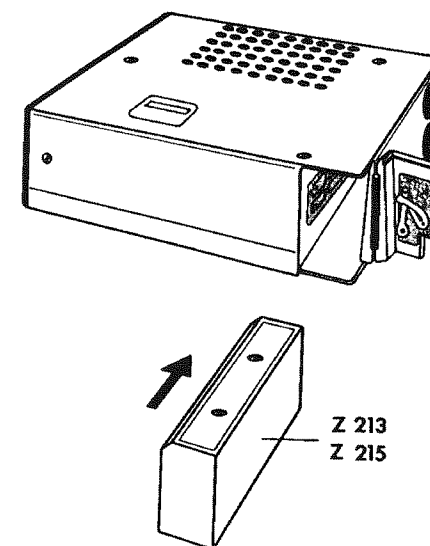

Fig. 3

1.3 Operating with the power pack Z 131

Using the power pack Z 131, the unit can be supplied with power from the ac power line at a voltage of 100 to 130 V and 200 to 240 V respectively. The power pack can be operated on a line frequency of 50 Hz or 60 Hz without the need for being changed over. The voltage selector can be reset with a coin.

Before making the connection to the power line, ascertain the prevailing line voltage and if necessary adjust the voltage selector correspondingly. When operating the unit in the 100 to 130 V range, exchange the 80 mA line fuse against the fuse supplied with the unit of 160 mA. The fuse mount on the power pack can be unscrewed with a small screwdriver (see Fig. 4).

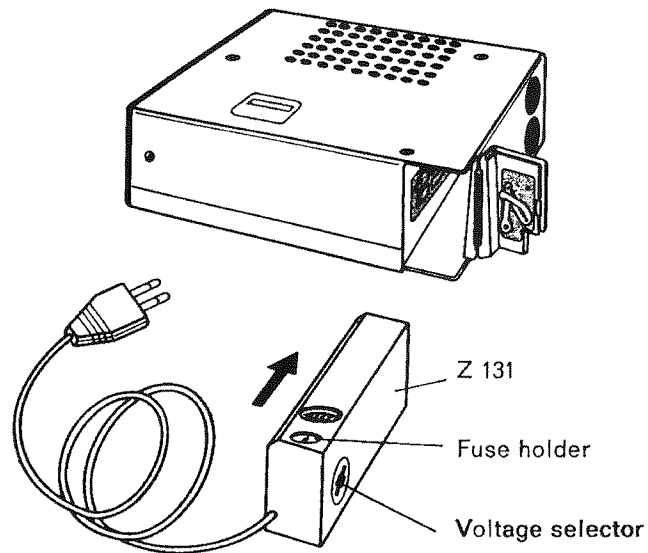

Fig. 4

With power line operation, the power sources fitted in the unit may remain in position. If a storage battery has been inserted, it will be automatically charged. The power pack is connected by way

of the connecting cable K 638 to the socket of the cassette recorder marked Δ . (See Fig. 5).

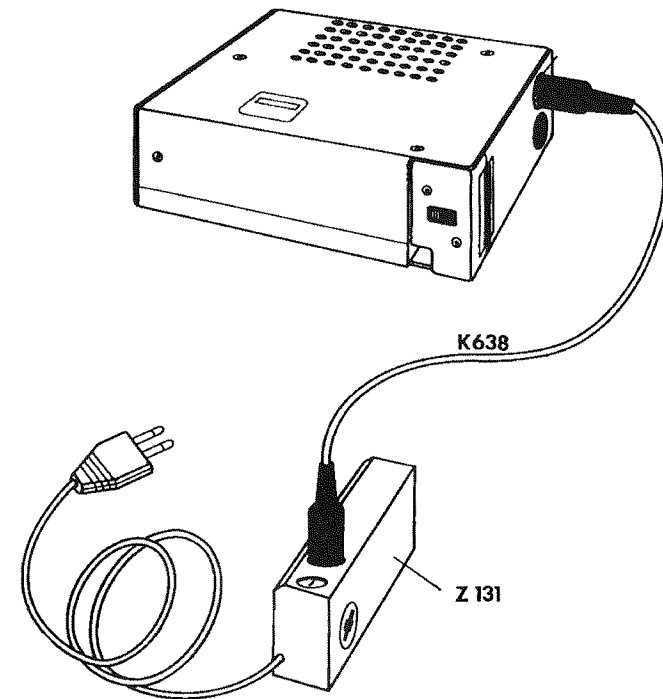

Fig. 5

The power pack can also be inserted in the battery compartment. When inserting, observe that the power pack is slid in with the contacts head first and in such a manner that the bevelled edge points towards the top left-hand corner. (See Fig. 4). The power line cable is then taken out through the cutout in the battery compartment lid. (See Fig. 4).

1.4 Operating on vehicle batteries

For operating on 12 V vehicle batteries, two tapping points are available for the power supply. The cigarette lighter socket or the tape-recorder socket on the car radio set.

When feeding the cassette recorder from the cigarette lighter socket, the car connecting cable K 719 is used. In this instance a connection is made with the socket \triangle on the cassette recorder.

When connecting the cassette recorder to a car radio set, either the car-radio connecting cable Mono K 528 or Stereo K 529 is used. In this instance, a connection is made with the AUTO-RADIO socket on the cassette recorder.

Further hints can be obtained by referring to the instructions for use accompanying the respective cable.

1.5 Charging the special types of storage batteries Z 213 or Z 215

The special types of storage batteries are invariably charged whenever the special type of storage battery is inserted in the battery compartment of the cassette recorder. It is then immaterial from which power source and via which connecting cable (K 638, K 719, K 528 and K 529) the unit is fed.

The charging of a fully discharged storage battery is completed after approx. 12 hours. With partially discharged storage batteries this period is correspondingly shorter.

An overcharging is absolutely impossible, since the automatic charger disconnects without fail. For this reason no cable connection at the charging end has to be disrupted and the storage battery can always remain in the battery compartment.

2. Connecting sockets

Socket "□" (see Fig. 6)

This socket serves for connecting the mono/stereo microphone arrangement Type M 640 as well as other UHER microphones and of the manual remote switch Type F 112 (refer to the list of accessories at the end of the operating instructions and the explanations under 6. Further hints).

"RADIO/PHONO" socket (see Fig. 6)

This socket serves for connecting mono and stereo radio receivers, record players, tape-recorders, cassette-recorders, tuners and amplifiers. Record players with magnetic pick-ups can only be connected via preamplifiers.

This socket is simultaneously the unit output, i.e. with playback, the connection of radio sets and amplifiers is made at the same socket.

"ACCESS" socket (see Fig. 6)

This socket serves for the connection of accessory units which are being employed in connection with the recording and playback of control pulses. In this manner the live sound-recording of films, the adding of sound to sub-standard films using the "ETS" method, as well as the control of automatic slide projectors is made feasible.

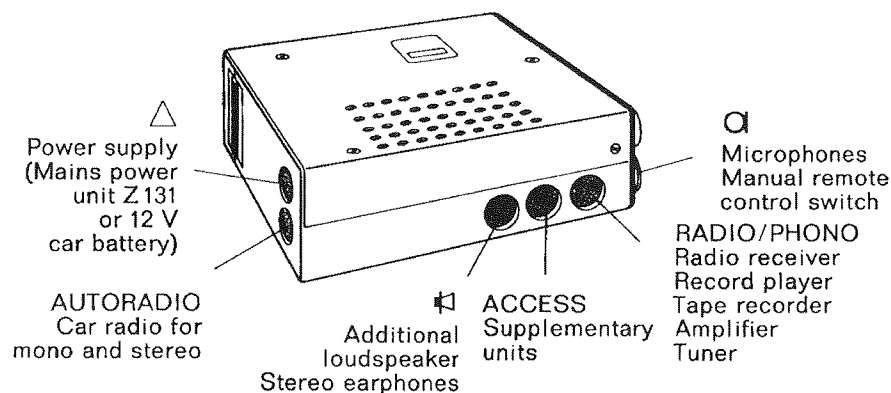

Fig. 6

Socket "✚" (see Fig. 6)

This socket serves for the connecting of extension speakers or stereo earphones (e.g. W 673).

Socket "△" (see Fig. 6)

Power pack Z 131 is connected to this socket via cable K 638 and the power supply from 12 V vehicle batteries provided via the car connecting cable K 719.

"AUTORADIO" socket (see Fig. 6)

This socket serves for the connecting of mono and stereo car radios for sound recording and playback as well as for the power supply of the special type of storage batteries Z 213 and Z 215 via the connecting cable K 528 or K 529.

3. Controls and their functions

You will find the identification numbers of the controls described below if you fold away the unit illustration at the end of the operating instructions.

Controls for injecting and ejecting the cassettes ①

As soon as the cassette has been inserted approx. $\frac{3}{4}$ of the way in the cassette lift, it is automatically pulled in completely. In order to bring the cassette into the operating position, the lever is then pressed until it clicks-in in the direction of the base of the unit. If the cassette is to be exchanged, push the lever in the direction of the unit cover. The cassette is ejected approx. $\frac{1}{4}$ of the way from the cassette lift and can then be quite easily lifted out completely.

On/off and tape run switch ②

With this switch the recorder is turned on and off, the direction of tape run selected and the tape run interrupted. For turning on, press the knob from the upper position marked OFF downwards towards the base of the unit. The measuring instrument ⑦ now

indicates the battery voltage and thus also the readiness for operation.

Now the direction of tape run can be selected by lightly tilting the knob into the required direction. The switch for the tape run will subsequently jump back again to the center position.

If the tape run is to be interrupted, the tape-run switch is pressed in position PAUSE. The tape run is halted until such time as the tape transport is started by a renewed actuating of the knob in the desired direction.

If the knob of the switch is moved to the upper position marked OFF, it will lock-in and the recorder is disconnected.

Respooling switch ◀◀ ▶▶ ③

The respooling switch is provided for the rapid search of given places in the program. For this purpose the knob of the switch is moved from its center position in the desired direction until it clicks in.

The place in the program can be located with the aid of counter ④. If the place has been reached, the knob of the switch is moved into the center position and the tape run started with the switch ② in the desired direction.

Counter ④

The counter is for marking given places in the program. When starting to record on a blank cassette, move the counter to 000 by pressing the zero setting button. If the counter position is accurately noted during the recording, the locating of given places on the tape during playback is quite easily possible.

Inspection window ⑤

A check on the spare quantity of tape can be made easily by looking through the inspection window in the cover of the unit if the window is illuminated by pressing the rotary control knob VOL. ⑥.

Control knob VOL. ⑥

This rotary control knob serves for setting the level control during recording and for regulating the volume during playback, as well as for switching on the illumination for the inspection window.

Level control and operating voltage indicator ⑦

The instrument continuously indicates the voltage of the power sources in the operating mode "Playback". If less than 6.5 V is indicated (red range of the lower scale), then the power sources are worn out or discharged and must be removed or recharged.

In the operating position "Record", the instrument indicates the intensity of the level control which can be adjusted with the control VOL.

Program indicator ⑧

The instrument indicates the direction of run in which the cassette recorder is being played.

Pushbutton "Record" ⑨

With each recording the previous taping is erased. In order to prevent an accidental erasing of existing recordings, this pushbutton must be held pressed before commencing a new recording and subsequently clicked-in with the switch ②. The pushbutton "Record" will only click in if a cassette has been inserted and the switch ② is pressed down from the position OFF.

Only suitable cassettes may be used for recording (see the illustration and explanations under 6. Further hints). With prerecorded cassettes as offered by the trade, the lugs A and B visible in the illustration are broken off. In this manner they are additionally protected by means of a locking device which disconnects the power supply of the cassette recorder before making fresh recordings or protected against accidental erasing.

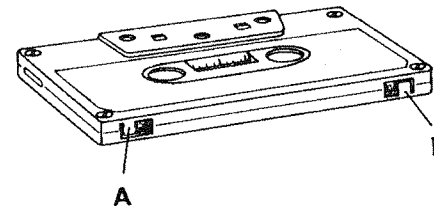

Fig. 7

ALC pushbutton ⑩

This pushbutton clicks-in when being pressed. This causes a recording level automatic system to be turned on which takes on a level control of the recording with control VOL. ⑥ such as would otherwise be required.

If the automatic recording level system is to be disconnected again, the pushbutton must be pressed once more. It unclicks and takes up its original position again.

Pushbutton \square INT. ⑪

This pushbutton clicks-in when pressed. This causes the built-in microphone to be turned on. In order to prevent acoustic feedback, which manifests itself by howling or a whistle (because the sound from the built-in loudspeaker is recorded again by the microphone), the pushbutton \square OFF ⑫ must be actuated additionally with this recording mode.

If the built-in microphone is to be disconnected again, pushbutton ⑪ must be pressed once more. It clicks out and resumes its original position.

Pushbutton \square OFF ⑫

This pushbutton clicks-in when pressed. This causes the built-in loudspeaker to be disconnected. This disconnection is required if a stereophonic playback is to be made via two loudspeakers or a pair of stereo earphones (e.g. W 673).

If the built-in loudspeaker is to be reconnected, press the pushbutton once more. It clicks out and resumes its original position.

4. Playback operation

The quality of playback is a function of the quality of the recording. In order to achieve hi-fi quality, recording and playback operation must invariably be conducted in conjunction with hi-fi equipment.

There are the following facilities for playback:

4.1 Playback via the built-in speaker

Playback may be made via the built-in speaker. Stereo recordings are then played back in mono.

4.2 Playback via external speaker or earphones

Socket ∇ permits the connection of a loudspeaker, a mono pair of earphones or twin loudspeakers (using the distribution cable K 633) or a pair of stereo earphones. For stereo playback, the built-in speaker is disconnected by actuating the pushbutton ∇ OFF $\text{\textcircled{2}}$.

4.3 Playback via stereo radio receivers or amplifiers

These types of units are connected to the RADIO/PHONO socket with the cable K 541. The loudspeaker built into the cassette recorder is disconnected by actuating pushbutton ∇ OFF $\text{\textcircled{2}}$. Volume control and tone control is carried out with the controls of the radio set or the amplifier.

4.4 Operating the cassette recorder

Playback operation must be carried out as follows after laying down the playback mode in accordance with 4.1 to 4.3:

1) Inserting the cassette

The cassette is always slipped into the cassette lift with side 1 (or A) pointing upwards and pointing to the left with the aperture for the tape (see Fig. 8). After the cassette has been inserted into

the cassette lift as far as approximately $\frac{3}{4}$ of the depth, it is pulled in completely by an automatic claw system. Then the lever $\text{\textcircled{1}}$ is pressed in the direction of the base of the unit until it clicks-in.

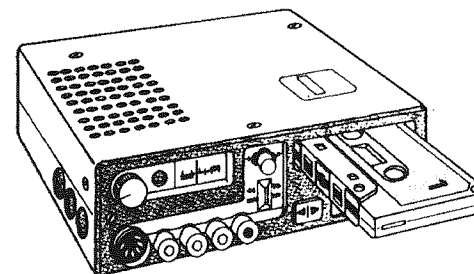

Fig. 8

2) Turning on the unit

Press switch $\text{\textcircled{2}}$ downwards in the direction of the base of the unit.

3) Setting the counter to 000

If spooled-on tape can be observed on both reel cores in the inspection window for the cassette (for illuminating the window press rotary knob VOL.), first of all move the respooling to the left in position \blacktriangleleft and observe on the counter when the respooling process is finished. In this case the counter remains stationary and can only be set to 000 by pressing the zero pushbutton.

4) Selecting the tape run direction

Tilt switch $\text{\textcircled{2}}$ to the right in position \blacktriangleright , playback commences.

5) Autoreversal

When on playback, an autoreversal device is permanently in operation. It performs the changeover from side 1 to side 2 of the cassette and vice versa at the end of tape. This process repeats itself until the recorder is switched off. From this it follows that the cassette does not have to be changed by hand for playing back the respective other side.

6) Program indication

The program indicator ⑧ shows which program, i.e. which side of the cassette is being played back.

7) Interrupting playback

Tilt switch ② downwards in position PAUSE. Playback will be interrupted until the switch ② is tilted once more in one of the directions of run.

8) Locating definite places in the program

By means of respooling switch ③ the tape can be wound on fast or rewound fast, permitting the desired place in the program to be located with the aid of the counter ④. When this place has been reached, then the rewind switch is moved to its center position and the tape run restarted by actuating the switch ②.

9) Terminating playback

Playback can either be terminated by ejecting the cassette with the aid of lever ① or by pressing the switch ② into position OFF. In both cases the power supply is disconnected simultaneously.

5. Recording operation

Recording can only be accomplished with cassettes whose two U-shaped lugs are still present on the rear of the cassette (see Fig. 7). Should there be a recess next to these lugs, this concerns a chromium-dioxide cassette. These recesses serve the automatic changing over of the unit to this type of tape.

5.1 Operating the recorder during recording

When operating the recorder during recording, observe the following sequence:

1) Connecting the sound sources

Connect microphone, Type M 640 to socket Q1. Radio receivers, tuners and amplifiers are connected to the RADIO/PHONO socket via the stereo audio-lead, Type K 541. Record players are also connected via the RADIO/PHONO socket in accordance with the instructions enclosed with the record player. Car radios are connected to the AUTORADIO socket using the corresponding car audio-lead, Type K 528 (mono) or Type K 529 (stereo).

2) Inserting the cassette

The cassette is slipped into the cassette lift with the side to be recorded on top and with the opening for the tape pointing to the left. After the cassette has been inserted up to $\frac{3}{4}$ of the depth in the cassette lift, it is pulled in completely by an automatic claw system. Then the lever ① is pressed in the direction of the base of the unit until it clicks-in. The start of the recording is determined by respooling, as required, using the respooling switch ③.

3) Setting the counter to 000

The counter is set to 000 by pressing the zero setting button. This adjustment must always be made at the tape start, in order to be able to carry out an accurate registration of the individual recordings with the aid of the counter.

4) Adjusting the recording level

In order to be able to carry out a test recording level, first keep the recording pushbutton ⑨ depressed and lock it with the switch ② by also depressing it. The Recording pushbutton will only lock-in if the switch ② is being pressed from the OFF position.

The recording level is adjusted by turning the VOL. control ⑥ and watching the measuring instrument ⑦. At the loudest passages in the program, the indication may only deflect as far as the 0-dB marking. Indications which run into the red section of the upper

scale signify an overloading of the recording and will be the cause of impure and distorted playback later on.

5) Starting to record

Having made a test of the recording level, the tape run can now be started by tilting the switch ② towards the right. In order to prevent an error in operation, the other direction of run is electronically blocked. The switch ②, however, can in fact be tilted towards the left, but there is no tape transport in this direction.

6) Interrupting the recording

The tape run can be interrupted by tilting the switch ② in the direction of PAUSE and continued by a renewed tilting towards the right in the direction ►. When recording with the microphone, Type M 640, the recording can also be interrupted and continued via the control switch on the microphone. Then the recording remains interrupted while the switch is in the retracted position.

With recordings via the socket RADIO/PHONO, a remote control via the manual remote switch Type F 112 is possible, the switch being connected via the socket □. Accurate instructions concerning this will be found under 6.1 Remote control via the manual remote switch, Type F 112.

7) Monitoring the recording

The recording can be monitored via the built-in speaker, external speakers or earphones. In the case of microphone recordings, monitoring is most suitably carried out via earphones (e.g. W 673). The built-in speaker must be disconnected by actuating the pushbutton ⚡ OFF, in order to make certain that howling and whistles, which would otherwise originate, are prevented.

8) Recording with the built-in microphone

For making a recording, press the pushbutton □ INT. ⑪ to connect the built-in microphone. Disconnect the built-in speaker by actuating the pushbutton ⚡ OFF, in order to prevent acoustic

feedback. The adjustment of the recording level is carried out as described previously.

Please also observe the explanations under para. 6. Further hints.

9) Recording with the automatic recording level control

All previously described recording modes can also be effected with the automatic recording level control. In this case, however, there is no need for operating the control knob VOL. ⑥ or for observing the level control indicator ⑦.

The automatic recording level control is turned on by actuating pushbutton ALC ⑩.

10) Terminating the recording

The recording can be terminated either by ejecting the cassette by means of lever ① or by pressing the switch ② in position OFF. In both instances the power supply is disconnected.

If respooling switch ③ is actuated during recording, the recording push-button clicks out and the recording is thus terminated. The unit is then in the operating position "Playback".

6. Further hints

6.1 Remote control via manual remote switch, Type F 112

(see Fig. 9)

When operating on playback, please always proceed in the following sequence:

1. Move slide switch of the manual remote switch to the lower position (start).
2. Connect manual remote switch to the cassette recorder via socket □.
3. Insert cassette and press lever ①. Turn on the recorder with switch ② and start tape transport by tilting the switch to the right for side 1 of the cassette.

4. The tape transport for side 2 of the cassette is effected by pressing the red pushbutton PROGRAM once. When pressing the pushbutton once more, side 1 of the cassette is played back, etc.
5. For interrupting playback, move the slide switch to position STOP.

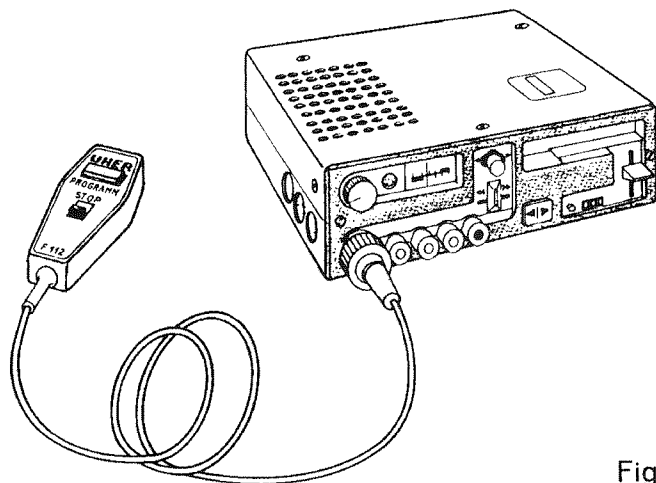

Fig. 9

When operating on recording via the socket RADIO/PHONO, please proceed in the following sequence:

1. Move slide switch of the manual remote switch to the lower position (start).
2. Connect manual remote switch to the cassette recorder via the socket Q and make the connection to the sound source via the socket RADIO/PHONO. Turn on sound source.
3. Insert cassette and press lever ①. Press recording pushbutton and lock-in by simultaneously pressing the switch ②.
4. Carry out test recording level control or press pushbutton ALC and then tilt switch ② to the right in position ►. Thus the tape run has been started and recording commences.

5. For interrupting the recording, move the slide switch to position STOP. Do NOT under any circumstances press the red pushbutton PROGRAM!
6. If the recording is to be continued, move the slide switch downwards into the starting position, etc.

6.2 Recordings with the built-in microphone

The built-in special capacitor microphone can be employed for all types of mono recordings. It possesses an omni-directional characteristic. The speaking distance from the microphone during the recording of conversations is approx. 20 in. Recording with the built-in microphone is particularly easy if the automatic recording level control is turned on additionally by actuating the pushbutton ALC.

The live recording of music should be carried out with external microphones, since the quality which can thus be obtained is considerably better.

The built-in microphone is very sensitive, i.e. recordings over greater distances, such as in the case of conferences, can be made. At the same time there is the possibility that a low inherent noise of the recorder and all ambient noises may be recorded alongside. High-quality recordings are therefore always only possible with the use of external microphones.

Microphone cable extensions are made for all UHER microphones quoted under Accessories with the use of cable, Type K 111.

With the setting up of microphones at the end of the operating instructions, the direction of the arrow indicates the sequence of interconnecting the microphone, extension cable K 111, adapter cable K 628 and cassette recorder.

Only the microphone, Type M 640 is extended directly via the cable, Type K 125.

6.3 Mono and stereo microphone recordings

All microphones in the UHER range of supply can be connected to your recorder. For mono recordings with one microphone use the

Fig. 10

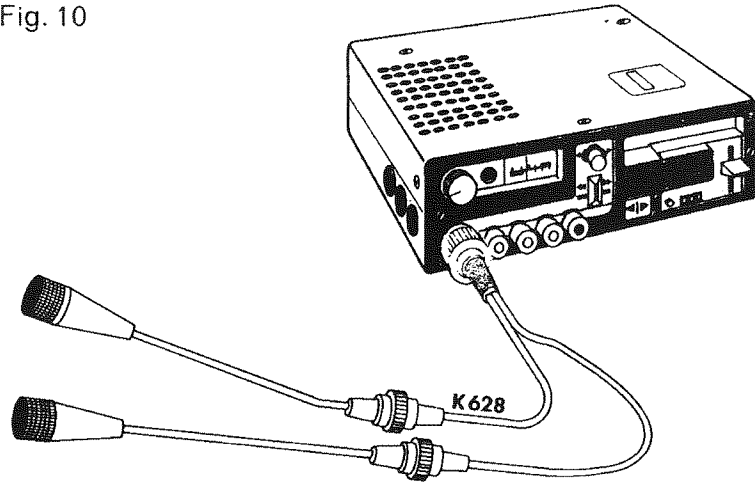

adapter, Type K 629, for stereo recordings with two individual microphones use the distribution cable, Type K 628. The illustration, Fig. 10, explains the connection.

Should several microphones be used for mono or stereo recordings, the connection is made via UHER STEREO-MIX 500, Type A 124, in accordance with the instructions included with the mixing console.

6.4 Recording and playback in conjunction with mono radios

The radio receiver is connected by way of the radio lead, Type K 541 together with the adapter, Typ K 837. With older models of radio receivers having a triple-pole standard socket for tape recording and playback, the audio lead, Type K 511 is used also in conjunction with the adapter, Type K 837. Illustration, Fig. 11, explains the connection.

6.5 Recording telephone conversations

Connect the telephone adapter, Type A 261 via the adapter, Type K 837 to the socket RADIO/PHONO. The recorder is operated in

the same manner as with the recording of a radio broadcast program. In order to facilitate the recording, the automatic recording level control may also be connected in this instance by actuating the pushbutton ALC.

6.6 Operating the recorder via the time switch, Type A 403

The power supply to your cassette recorder is effected by inter-connecting the power pack, Type Z 131 via the time switch, Type A 403.

For recording insert a cassette, press the lever ① and turn on the recorder with switch ②. Connect the automatic start switch, Type K 839 to the socket ACCESS., which will start the tape run of the recorder as soon as the time switch turns on the power supply.

If a recording is to be controlled via the time switch, the sound source must be connected via the time switch in addition and the cassette recorder made ready to operate.

6.7 Using the stereo filter A 311

The stereo filter A 311 serves as an adapter cable for the connection of stereo cassette recorders via the stereo audio-lead K 541 to older models of stereo radio receivers with too low a pilot tone suppression. It will always be required whenever, during the play-

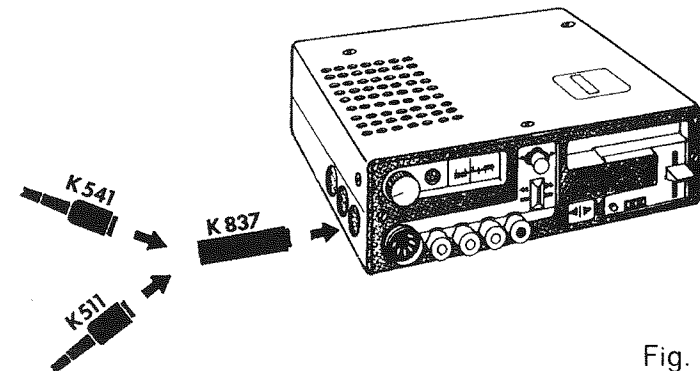

Fig. 11

back of a stereo recording, a well-audible whistle in the background is heterodyning the recording.

6.8 Live sound recording and adding sound to sub-standard films

With your cassette recorder you possess the facility for carrying out synchronous, pulse-controlled addition of sound to sub-standard films. When coupling the cassette recorder with movie cameras which emit a pulse, a synchronous live sound-recording is offered. One head system of the four-tier sound head is taken out via the contacts 6 and 4 (4 = chassis-ground) of the socket ACCESS. and serves for the recording and playback of the sync pulses. In addition, attachments may also be connected which cater for the slide change of automatic slide projectors by means of pulse control.

With all recordings of control pulses, either a blank cassette or one which has been perfectly erased on all four tracks must be employed.

6.9 Erasing without a new recording

With each recording, a possibly existing previous recording is automatically erased. Should in special cases an erasure only have to be made, the cassette recorder is operated exactly as with a recording. Here, control knob VOL. ⑥ is turned fully counter-clockwise.

6.10 Using iron-oxide and chromium-dioxide cassettes

The UHER CR 210 stereo permits the use of both iron-oxide and chromium-dioxide cassettes for recording and playback. The changeover from one tape grade to another already takes place automatically during the insertion in the cassette lift of the recorder. The recesses located next to the U-shaped lugs at the rear of the cassette serve this purpose (see Fig. 7).

7. Care and maintenance

The UHER CR 210 stereo has been manufactured in accordance with the very latest production methods, carefully tested and functions practically free from maintenance. The moving parts do not require to be oiled or greased under normal operating conditions. The state of the drive system is checked by our service departments during maintenance work.

All that is needed from time to time, is to clean the magnetic heads of the recorder. For this purpose cleaning cassettes are obtainable from your qualified dealer. The cleaning cassette is inserted in the recorder in the same manner as a normal cassette and allowed to run through in the Playback position. In the interests of a satisfactory cleaning effect, the cleaning cassette must be used full length, i.e. from start to finish.

The satisfactory operation of the recorder depends upon the accurate interplay of electrical and mechanical functions. Should faults occur, whose causes experience has shown to be always of minor importance, it is therefore not advisable to interfere with the recorder without sufficient knowledge of the subject. In such cases an expert or our nearest service department should be consulted.

Compact cassettes

There are a number of compact cassettes circulating in the trade, whose dimensions do not fully comply with the international regulations. Such cassettes can often be used in conjunction with the simple types of recorders.

If, however, a high-quality recorder such as the UHER CR 210 stereo also makes demands on the precision of the cassette, it may happen that either the tone quality is reduced or faults develop. In such cases the cause should not be looked for in the cassette recorder, but in possibly unsatisfactory cassettes.

Thus, for example, a special protective device of the cassette recorder takes care that the drive system is turned off if the tape should tear or jam in the cassette.

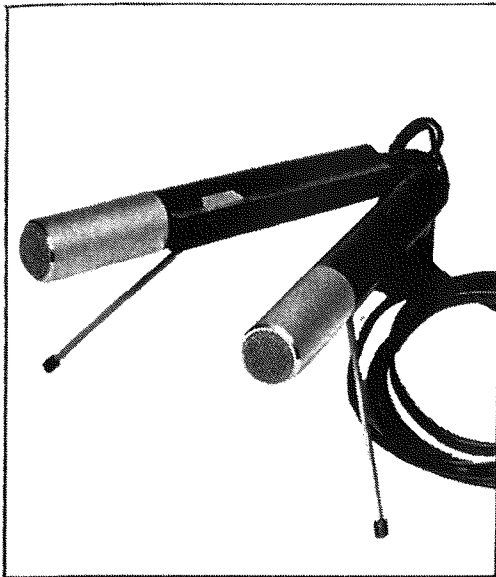

M 640

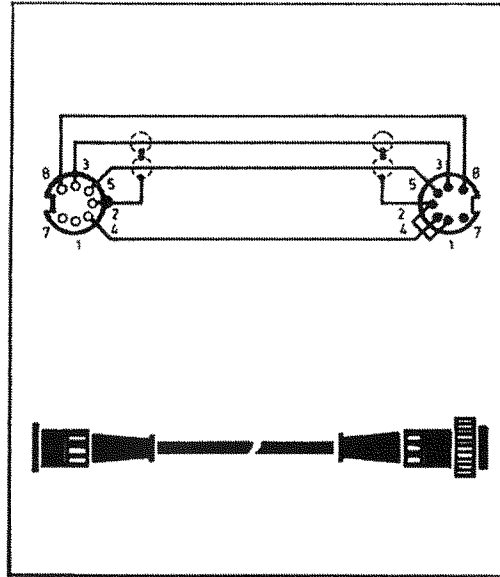

K 125

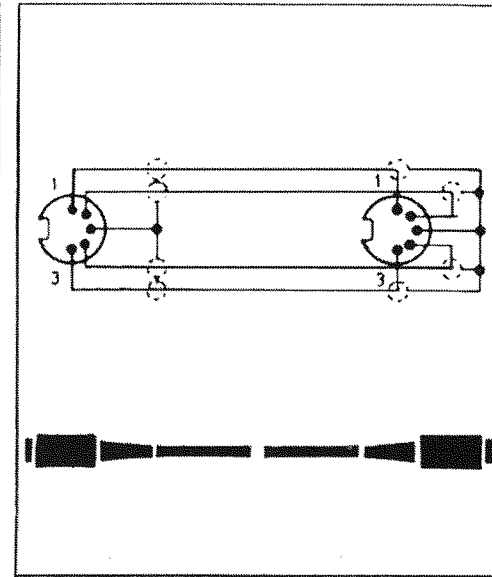

K 541

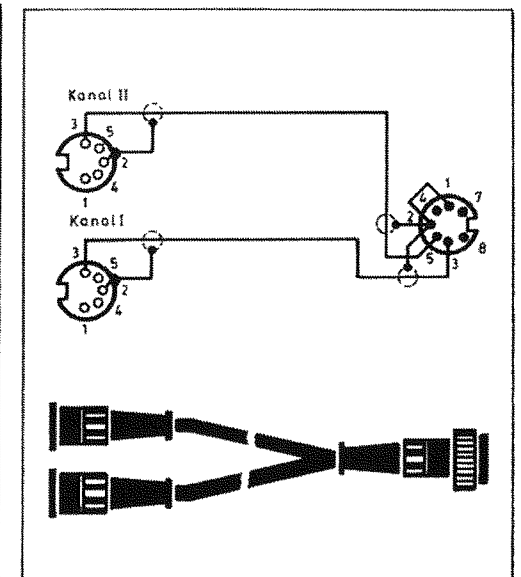

K 628

- M 640 → (K 125) → CR 210 stereo
- M 136 → (K 111) → K 629 → CR 210 stereo
- M 517 → (K 111) → K 629 → CR 210 stereo
- M 534 → (K 111) → K 629 → CR 210 stereo
- M 634 = 2 x M 534 → (2 x K 111) → K 628 → CR 210 stereo
- M 537 → (K 111) → K 112, K 113, K 114
K 115 → K 629 → CR 210 stereo
- M 538 → (K 111) → K 112, K 113, K 114
K 115 → K 629 → CR 210 stereo
- M 539 → (K 111) → K 112, K 113, K 114
K 115 → K 629 → CR 210 stereo
- M 815 → (K 111) → K 112, K 113, K 114
K 115 → K 629 → CR 210 stereo
- M 822 → (K 111) → K 629 → CR 210 stereo

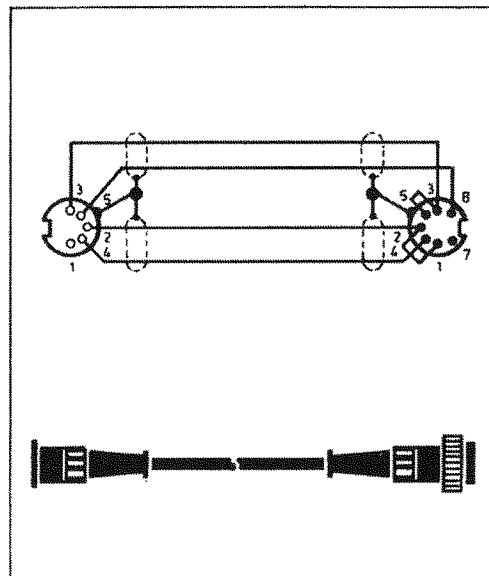

K 629

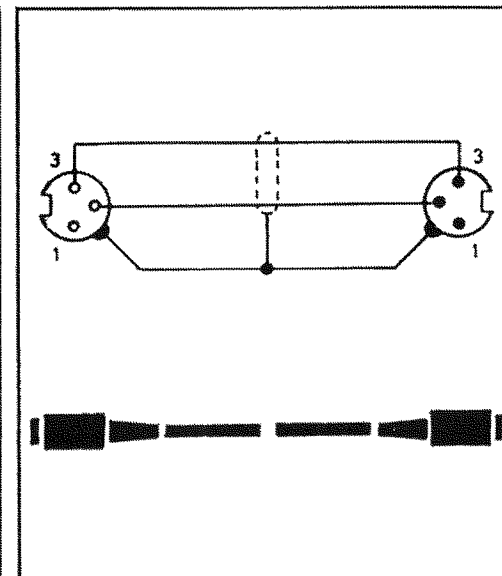

K 111

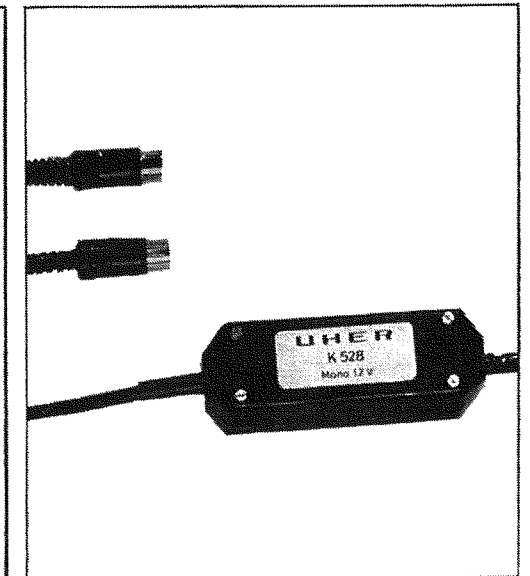

K 528

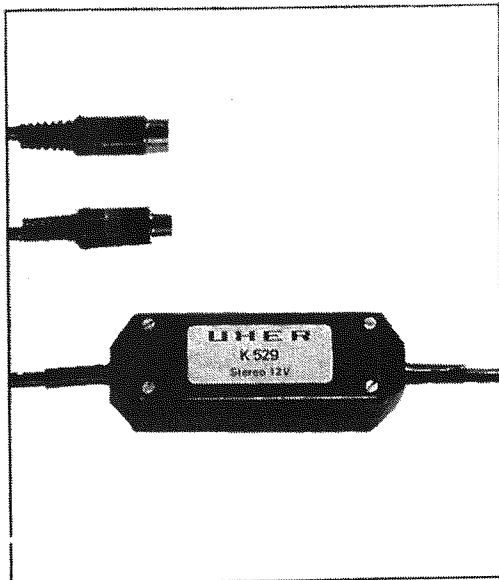

K 529

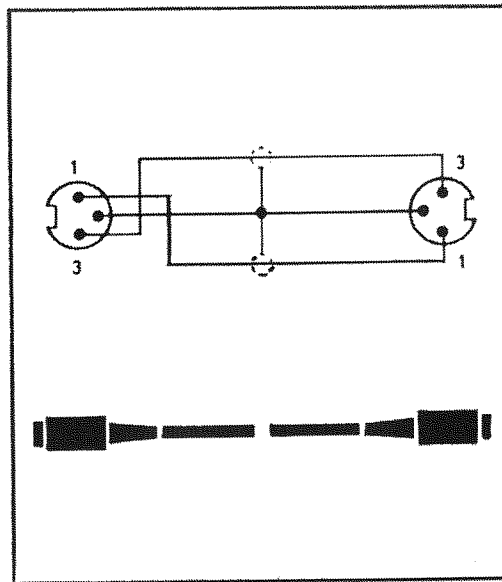

K 511

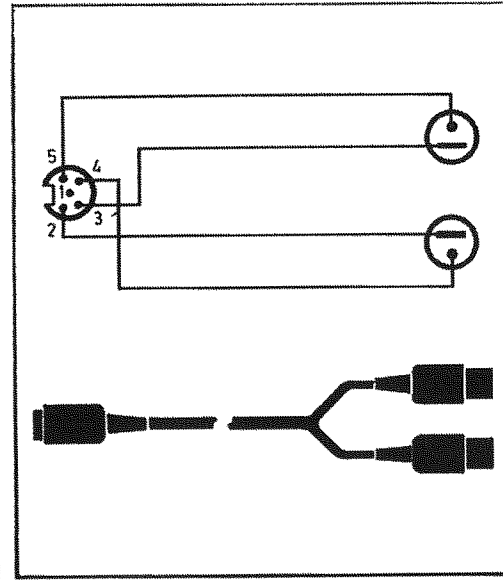

K 633

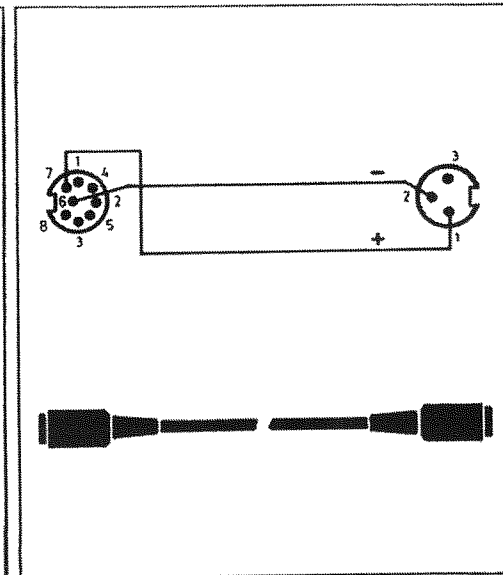

K 638

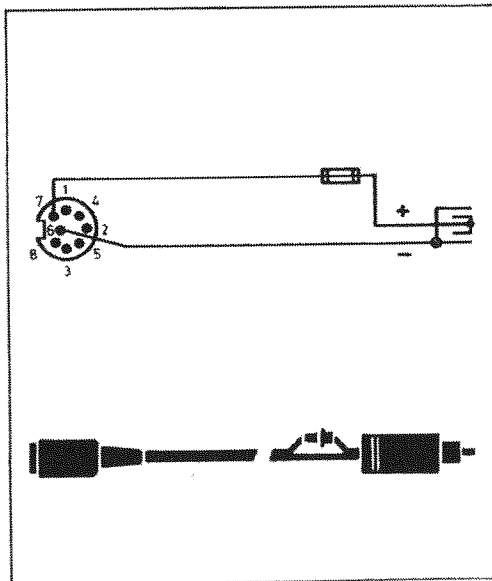

K 719

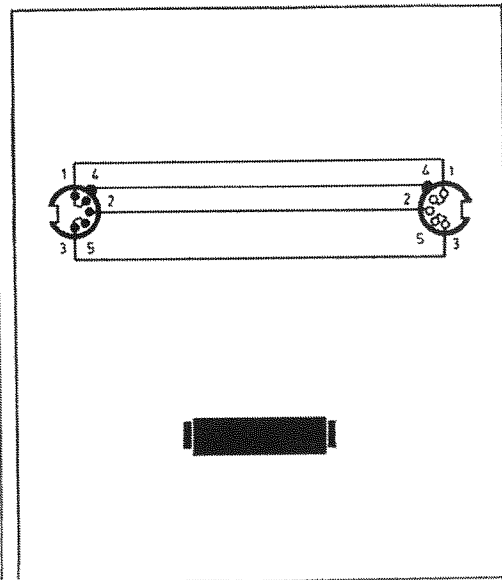

K 837

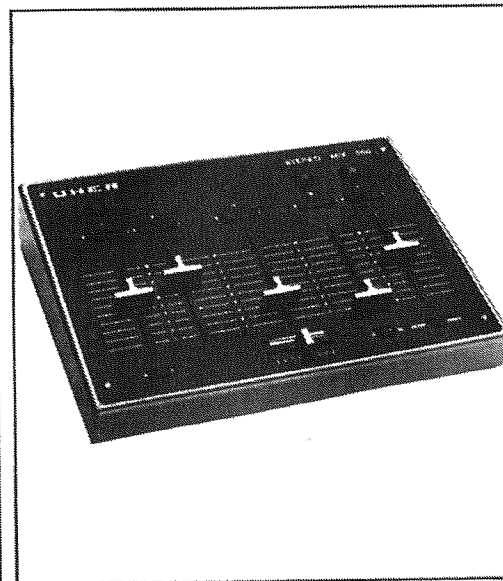

A 124

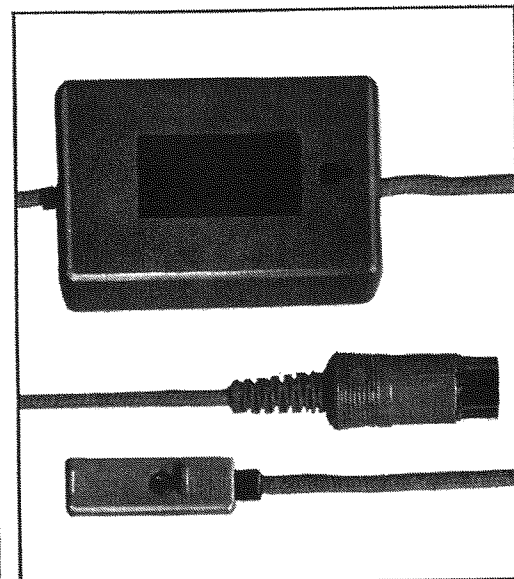

A 261

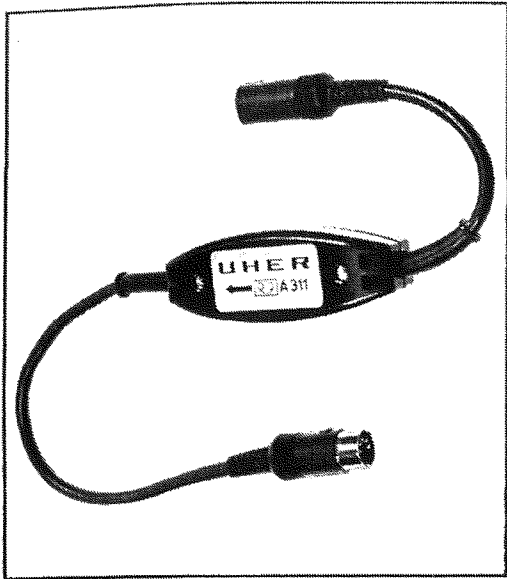

A 311

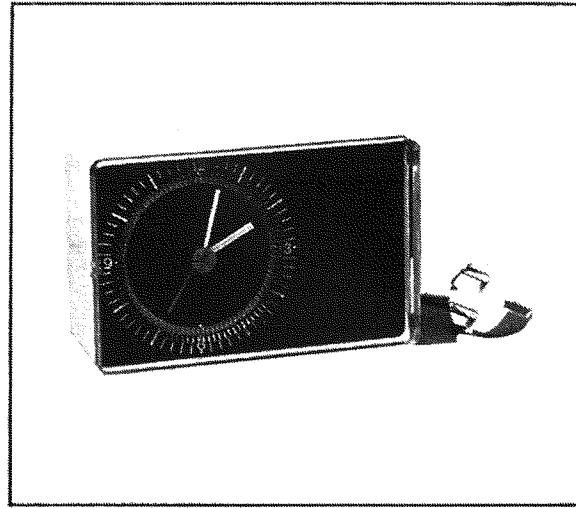

A 403



W 673



F 112

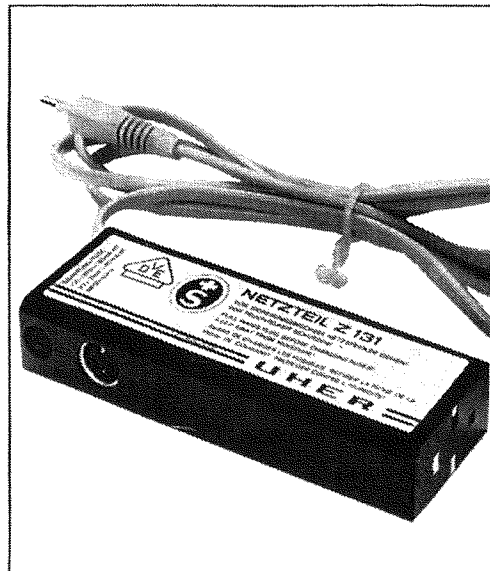

Z 131

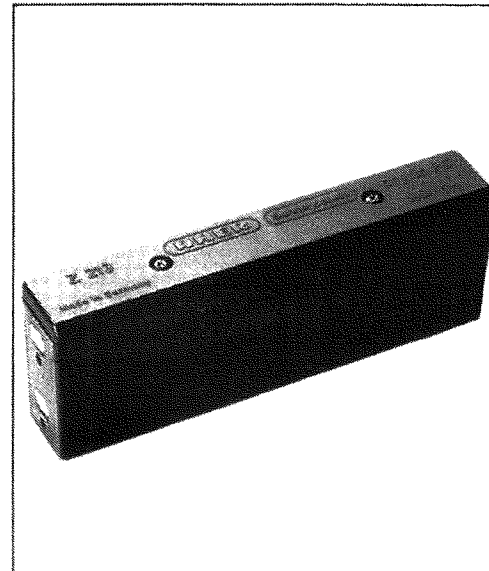

Z 213

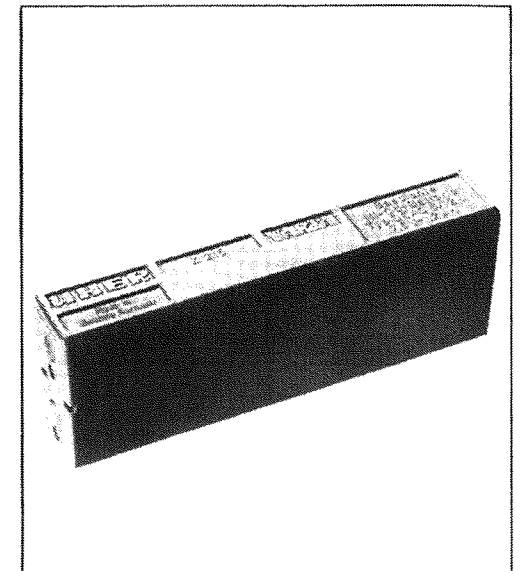

Z 215

