

Service Manual

Plasma Television

TH-42PA60L

GP9DE Chassis

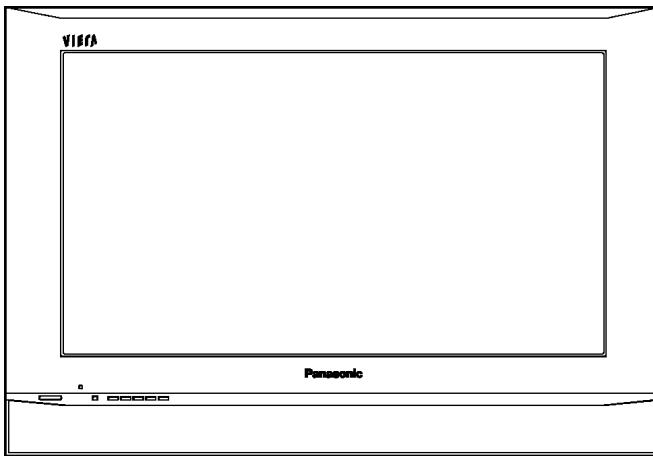

Please file and use this manual together with the service manual for Model No.TH-42PA60A, Order No.ITD0603007.

Specifications

Power Source	AC 110-220 V, 50 / 60 Hz
Power Consumption	
Average use	294 W
Standby condition	0.3 W
Plasma Display panel	
Drive method	AC type
Aspect Ratio	16:9
Contrast Ratio	Max 10000:1
Visible screen size (No. of pixels)	106 cmV 920 mm (W) × 518 mm (H) × 1,056 mm (diagonal)
Sound	
Speaker	12 cm × 6 cm × 2 pcs, 8 Ω
Audio Output	20 W (10 W + 10 W), 10% THD

Panasonic®

© 2006 Matsushita Electric Industrial Co., Ltd. All rights reserved. Unauthorized copying and distribution is a violation of law.

**Receiving Systems /
Band name**

1. PAL-M	Reception of broadcast transmissions and Playback from VCR or DVD
2. PAL-N	
3. NTSC	

**Receiving Channels
(Regular TV)**
VHF BAND
2-13 (NTSC M USA)

UHF BAND
14-69 (NTSC M USA)

CATV
1-125 (USA CATV)

Aerial - Rear

VHF / UHF

Operating Conditions
Temperature : 0 °C - 40 °C

Humidity : 20 % - 80 % RH (non-condensing)

Connection Terminals

AV1 Input AUDIO L-R	RCA PIN Type × 2	0.5 V[rms]
VIDEO	RCA PIN Type × 1	1.0 V[p-p] (75 Ω)
S VIDEO	Mini Din 4-pin	Y: 1.0 V[p-p] (75 Ω) C: 0.286 V[p-p] (75 Ω)
AV2 Input AUDIO L-R	RCA PIN Type × 2	0.5 V[rms]
VIDEO	RCA PIN Type × 1	1.0 V[p-p] (75 Ω)
COMPONENT	Y P _B /C _B , P _R /C _R	1.0 V[p-p] (including synchronization) ±0.35 V[p-p]
AV3 Input AUDIO L-R	RCA PIN Type × 2	0.5 V[rms]
VIDEO	RCA PIN Type × 1	1.0 V[p-p] (75 Ω)
COMPONENT	Y P _B /C _B , P _R /C _R	1.0 V[p-p] (including synchronization) ±0.35 V[p-p]
Others HDMI Input	TYPE A Connector	
Audio Input	RCA PIN Type × 2	0.5 V[rms]
Monitor AUDIO L-R	RCA PIN Type × 2	0.5 V[rms] (high impedance)
Output VIDEO	RCA PIN Type × 1	1.0 V[p-p] (75 Ω)

Dimensions (W × H × D)

1,068 mm × 701 mm × 97 mm (TV Set only)

1,068 mm × 764 mm × 320 mm (With Pedestal)

Weight

29.0 kg Net (TV Set only)

31.0 kg Net (With Pedestal)

Notes:

- Design and Specifications are subject to change without notice. Weight and Dimensions shown are approximate.

 **WARNING**

This service information is designed for experienced repair technicians only and is not designed for use by the general public. It does not contain warnings or cautions to advise non-technical individuals of potential dangers in attempting to service a product. Products powered by electricity should be serviced or repaired only by experienced professional technicians. Any attempt to service or repair the product or products dealt with in this service information by anyone else could result in serious injury or death.

CONTENTS

	Page	Page
1 Difference PCB Structure sheet	4	
2 Service Mode Function	5	
2.1. How to enter SERVICE 1	5	
2.2. How to enter SERVICE 2	5	
2.3. Option Description	7	
3 Adjustment	9	
3.1. PAL panel white balance adjustment	9	
3.2. HD white balance adjustment	10	
3.3. Sub bright adjustment	11	
3.4. ABL adjustment	12	
		3.5. Sub-Contrast adjustment
		13
		4 Conductor Views
		15
		4.1. TU-Board
		15
		4.2. DG-Board
		16
		5 Schematic and Block Diagram
		19
		5.1. Schematic Diagram Note
		19
		5.2. Main Block Diagram
		20
		5.3. TU-Board Block and Schematic Diagram
		21
		5.4. DG-Board (1 of 3) Block Diagram
		22
		5.5. DG-Board (2 of 3) Block Diagram
		23

5.6. DG-Board (3 of 3) Block Diagram	24	6.1. Parts Location	33
5.7. DG-Board (1 of 8) Schematic Diagram	25	6.2. Packing Exploded Views (1)	34
5.8. DG-Board (2 of 8) Schematic Diagram	26	6.3. Packing Exploded Views (2)	35
5.9. DG-Board (3 of 8) Schematic Diagram	27	6.4. Packing Exploded Views (3)	36
5.10. DG-Board (4 of 8) Schematic Diagram	28	6.5. Stand Exploded Views	37
5.11. DG-Board (5 of 8) Schematic Diagram	29	6.6. Mechanical Replacement Parts List (PDP TV)	38
5.12. DG-Board (6 of 8) Schematic Diagram	30	6.7. Mechanical Replacement Parts List (Stand)	39
5.13. DG-Board (7 of 8) Schematic Diagram	31	7 Electrical Replacement Parts List	40
5.14. DG-Board (8 of 8) Schematic Diagram	32	7.1. Replacement Parts List Notes	40
6 Parts Location & Mechanical Replacement Parts List	33	7.2. Electrical Replacement Parts List	41

1 Difference PCB Structure sheet

■Print List

Board name	Part No.		Function	Remarks
	TH-42PA60A	TH-42PA60L		
C1	TNPA3799AB		Data Draiver (Left)	
C2	TNPA3800AB		Data Draiver (Right)	
S	TZTNP01BMTB		Format Converter, Plasma AI Processor	
H	TNPA3760AC		AV Terminal, AV switch	
HC	TNPA3852		JIG Connection	
K	TNPA3603AH		Remote receiver, LED, Keyscan	
P	TNPA3911AB		Power Supply	
PA	TNPA3761AH		DC-DC Converter, Power SOS	
S	TNPA3604AD		Power Switch	
SC	TNPA3794AB		Scan Drive	
SD	TNPA3875AB		Scan Out (Lower)	
SS	TNPA3795AB		Sustain Drive	
SU	TNPA3874AB		Scan Out (Upper)	
DG	TNPA3756CQ	TNPA3756CY	Digital Signal Processor	Changed
TA	TNPA3768AC	-----	Tuner	Deleted
TU	-----	TNPA3851	Tuner	Added

2 Service Mode Function

MPU controls the functions switching for each IICs through IIC bus in this chassis. The following setting and adjustment can be adjusted by remote control in Service Mode.

2.1. How to enter SERVICE 1

1. In sound menu, set BASS to MAXIMUM, and set TREBLE to MINIMUM.
2. Set the Volume to minimum, and set the off timer.
3. Simultaneously press **Recall** button on remote control and **DOWN** button [$-\sqrt{\vee}$] on the TV set.

2.2. How to enter SERVICE 2

1. Set the channel to CH99.
2. Select the EQ 12kHz.
3. Press Mute button on remote control and DOWN button [$-\sqrt{\vee}$] on the TV set.

Note:

To exit to Service mode, press EXIT or Power button on remote control.

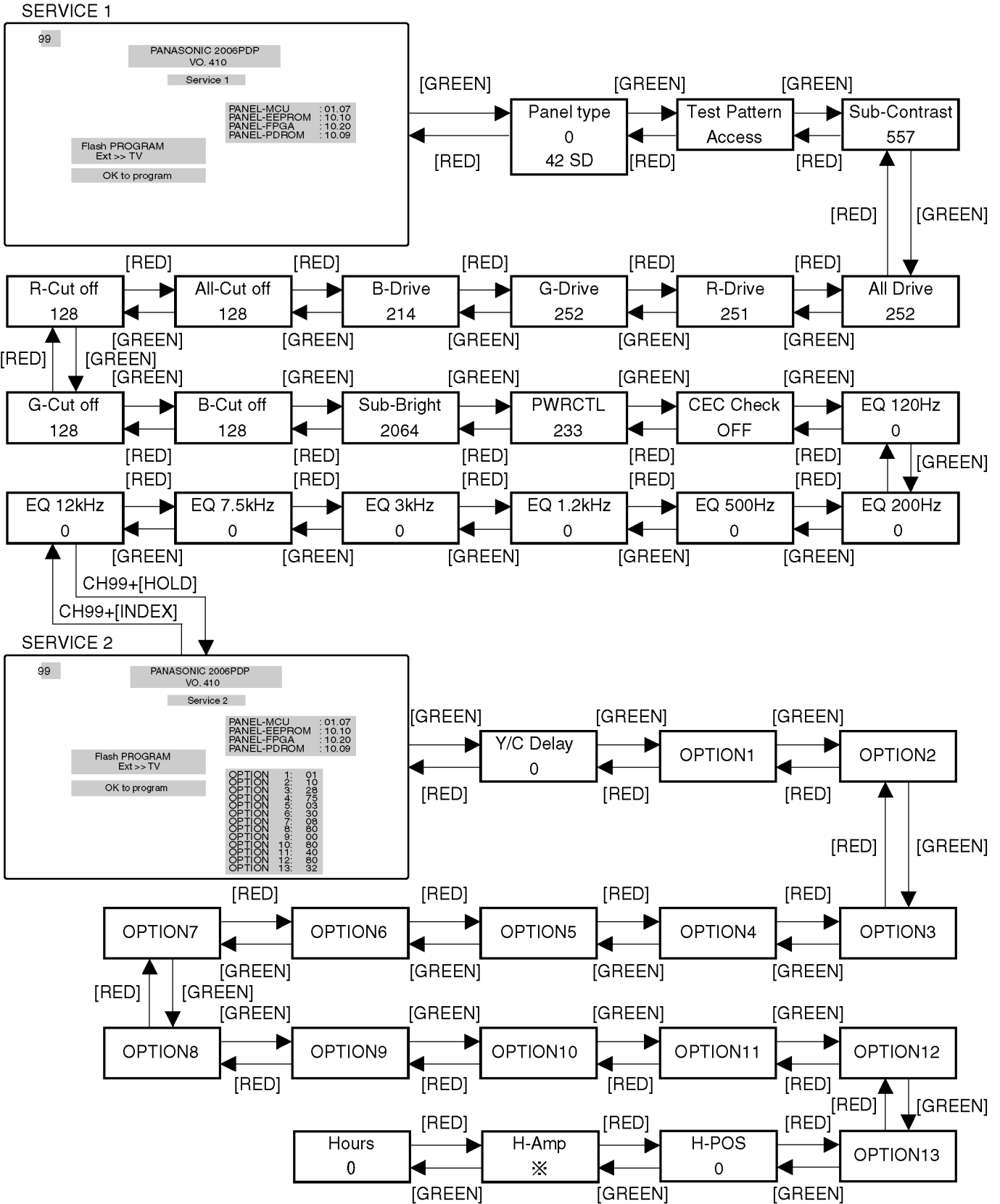

※ : This item appears when "component" selecting

Key Command

- Press the **RED/GREEN** button to step up/down through the functions.
- Press the **YELLOW/BLUE** button to change the function values.
- Press the **OK** button after each adjustment has been made to store the required values.

2.3. Option Description

option1	05		
b0	1	Colour system	Auto(1)
b1	0		SECAM(1)
b2	1		NTSC(1)
b3	0		M.NTSC(1)
b4	0	A2 select 6.5MHz	5.742MHz(0) 6.742MHz(1)
b5	0	SIF	4.5/5.5/6.0/6.5(0), 5.5/6.0/6.5(1)
b6	0		5.5/6.5/(2), 6.0/6.5(3)
b7	0	free	
option2	01		
b0	1	A2 enable	4.5(1)
b1	0		5.5(1)
b2	0		6.0(1)
b3	0		6.5(1)
b4	0	NICAM enable	4.5(1)
b5	0		5.5(1)
b6	0		6.0(1)
b7	0		6.5(1)
option3	1A		
b0	0	SASO enable	SASO enable(1)
b1	1	Fine tuning	Enable(1)
b2	0	Search speed	Slow(1) Fast(0)
b3	1	Tuner	MACO tuner (1), Others (0)
b4	1	HYPHER	UHF only (0), UHF/VHF (1)
b5	0	IF I2C	I2C controlled Tuner IF module (1)
b6	0	NICAM C4 bit	enable(1)
b7	0	Blue Back	BLUE BACK on/off selection in menu(0)
option4	08		
b0	0	Aspect AUTO	enable(1)
b1	0	S1/S2 enable	enable(1)
b2	0	ID-1	enable(1)
b3	1	User aspect Just	enable(1)
b4	0	User aspect 14:9	enable(1)
b5	0	ALBD 14:9	14:9 enable, Zoom3 disable at self wide(1)/ Zoom1, Zoom3 enable at self wide (0)
b6	0	TEXT	enable(1)
b7	0	TEXT TOP	TOP enable (1)
option5	03		
b0	1	CH Blanking	Blanking enable (1)
b1	1	AV Blanking	Blanking enable (1)
b2	0	Noise mute	Noise mute enable(0)
b3	0	sub picture	without sub-picture(0), with sub-picture(1)
b4	0	2tuner	2tuner(1),1tuner(0)
b5	0	AV Input	3rotation(1) / 2rotation without front RCA (0)
b6	0	Panel (LCD)	Samsung Panel(1)/SHARP Panel(0)
b7	0	Large size (LCD)	32(1)/26(0) for LCD
option6	20		
b0	0	SD module	with SD module (1)
b1	0	SD module Ext.Rec(PAL)	enable(1)
b2	0	SD module Ext.Rec(NTSC)	enable(1)
b3	0	SD module Ext.Rec(SECAM)	enable(1)
b4	0	IDTV	enable(1)
b5	1	HDMI	enable(1)
b6	0	Ext. HV input	without HV input(0) / with HV input(1)
b7	0	PC	enable(1)
option7	11		
b0	1	Asia	Asia(1),europe(0)
b1	0	Australia	Australia(1)
b2	0	Ireland/India	India(1)
b3	0	UK/Korea	Korea(1)
b4	1	Lang1	Large(0)/Small(1)
b5	0	Lang2	OSD Image:With Arabic(1)
b6	0	Lower POS	Lower POS enable(1)
b7	0	Owner ID	Enable(1)

option8	40	Euro option	
b0	0	ACI all country	ACI enable(1), only Netherlands(0)
b1	0	ACI auto MP	ACI auto multi package enable (1)
b2	0	ACI offset	ACI offset for VCR prog. enable(1)
b3	0	Power up EC-Mode	Power on EC enable (1)
b4	0	AVLink	Q-Link off selectable in menu (1)
b5	0	Volume correction	TV Volume coorrection enable (1)
b6	1	MPX/NICAM display	Display NICAM (0), Display MPX (1)
b7	0	Albd Reset Off	enable(1)
option9	60		
b0	0	CH Plan	ASIA / M.E. / HK/UK / CHINA(1)
b1	0		NZ/INDNES(1)
b2	0		AUSTRALIA(1)
b3	0		E.EUROPE(1)
b4	0		SPECIAL(1)
b5	1		AMERICA(1)
b6	1		CATV(1)
b7	0		JAPAN(1)
option10	00		
b0	0	NICAM priority	ASIA/M.E.(1)
b1	0		HK/UK(1)
b2	0		CHINA(1)
b3	0		NZ/INDN(1)
b4	0		AUSTRALIA(1)
b5	0		E.EURO(1)
b6	0		SPECIAL(1)
b7	0	HDMI AVI Aspect	enable(1)
option11	4C	Additional	
b0	0	Remocon Type	Delux(1) / Leader(0)
b1	0	Environment AI (PDP)	enable, with viewing mode auto (1) / disable, without viewing mode auto(0)
b2	1	WSS14:9 off	WSS 14:9 off (1)
b3	1	Child lock	Child Lock on: Tuning Menu skip(1)
b4	0		
b5	0	Contrast AI	enable(1)
b6	1	Service H-POS	enable(1)
b7	0	Service V-VOS	enable(1)
option12	19	Additional	
b0	1	last memory of aspect	each source(1) / ALL source(0)
b1	0	Reserved	
b2	0	TEXT Ch Refresh	refresh enable(1) / disenable(0)
b3	1	STILL	1:Disable / 0:Enable
b4	1	LATIN	Latin:SAP/Fixed SIF4.5MHz/PAL-M,N/CC/Black level/Language
b5	0	SRS	enable(1)
b6	0	HDMI Quali TV	enable(0)
b7	0	HDMI EC function	enable(1)
option13	0A	Additional	
b0	0	DVB ALBD	enable(1)
b1	1	HDMI port	enable(0) 2 ports model/(1)1port model (only for TV MCU port setting)
b2	0	HDMI format error OSD	display(0)/not display(1)
b3	1	CEC control	enable(0)
b4	0	Aspect 4:3 FULL	enable(0)
b5	0	FTZ	enable(1)
b6	0		
b7	0		

3 Adjustment

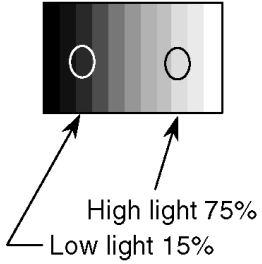

3.1. PAL panel white balance adjustment

Instrument Name	Connection	Remarks												
<ul style="list-style-type: none"> W/B pattern (PAL-M or NTSC signal) Color analyzer (Minolta CA-100 or equivalent) 	RF input Panel surface	User setting: Normal												
Procedure		Remarks												
<ul style="list-style-type: none"> Aging time is longer than 15min. Make sure the front panel to be used on the final set is fitted. Make sure a color signal is not being shown before adjustment. Put the color analyzer where there is little colour variation. <p>Complete the adjustment within 10 minutes after the turn on electricity.</p> <p>Turn on the power supply again when it is not possible to complete it by aging etc.</p> <ol style="list-style-type: none"> Display the white balance pattern. Check that the color balance is "cool". Enter the <Service1> mode. Select "G-CUTOFF" item, using the color-key "Red" or "Green", and set to "128", using the color-key "Yellow" or "Blue". Also, "B-CUTOFF" and "R-CUTOFF" set to "128". Set "G-DRIVE" at "224". Touch the signal receiver of color analyzer to the highlight window's center, and adjust B drive and R drive so x, y become the "Color balance Cool" in the below table. Set "ALL-DRIVE" to "252". Set colorbalance to "Normal". Fix G cutoff , B cutoff and R cutoff at "128". Fix G drive at "224". Adjust B drive and R drive so the highlight window's x, y become the "Color balance "Normal" in the below table. Set "ALL-DRIVE" to "252". Set color balance to "Warm". Set G cutoff, B cutoff and R cutoff to "128". Set G drive to "224". Adjust B drive and R drive so the highlight window's x, y become the "Color balance Warm" shown in the below table. Set "ALL-DRIVE" to "252". 		Picture menu : Dynamic ASPECT : 16:9												
<p>1. Highlight section</p> <p>Signal amplitude 75%</p> <p>PAL-M or NTSC White Balance Pattern</p> 														
<p>Table 1. Color balance target value</p> <table border="1"> <thead> <tr> <th>Color Temperature</th> <th>x</th> <th>y</th> </tr> </thead> <tbody> <tr> <td>Cool</td> <td>0.276</td> <td>0.276</td> </tr> <tr> <td>Normal</td> <td>0.288</td> <td>0.296</td> </tr> <tr> <td>Warm</td> <td>0.313</td> <td>0.329</td> </tr> </tbody> </table>		Color Temperature	x	y	Cool	0.276	0.276	Normal	0.288	0.296	Warm	0.313	0.329	
Color Temperature	x	y												
Cool	0.276	0.276												
Normal	0.288	0.296												
Warm	0.313	0.329												

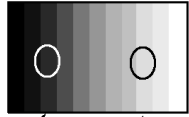
3.2. HD white balance adjustment

Instrument Name	Connection	Remarks												
<ul style="list-style-type: none"> 1080i W/B Pattern Color analyzer(Minolta CA-100 or equivalent) 	<ul style="list-style-type: none"> RF input Panel surface 	User setting: Normal												
Procedure		Remarks												
<p>• Aging time is longer than 15min.</p> <p>• Make sure the front panel to be used on the final set is fitted.</p> <p>• Make sure a color signal is not being shown before adjustment.</p> <p>• Put the color analyzer where there is little colour variation.</p> <p>Complete the adjustment within 10 minutes after the turn on electricity. Turn on the power supply again when it is not possible to complete it by aging etc.</p> <ol style="list-style-type: none"> 1. Display the white balance pattern. 2. Check that the color balance is "cool". 3. Enter the <Service1> mode. 4. Select "G-CUTOFF" item, using the color-key "Red" or "Green", and set to "128", using the color-key "Yellow" or "Blue". Also, "B-CUTOFF" and "R-CUTOFF" set to "128". 5. Set "G-DRIVE" at "224". 6. Touch the signal receiver of color analyzer to the highlight window's center, and adjust B drive and R drive so x, y become the "Color balance Cool" in the below table. 7. Set "ALL-DRIVE" to "252". 8. Set colorbalance to "Normal". 9. Fix G cutoff , B cutoff and R cutoff at "128". 10. Fix G drive at "224". 11. Adjust B drive and R drive so the highlight window's x, y become the "Color balance Normal" in the below table. 12. Set "ALL-DRIVE" to "252". 13. Set color balance to "Warm". 14. Set G cutoff, B cutoff and R cutoff to "128". 15. Set G drive to "224". 16. Adjust B drive and R drive so the highlight window's x, y become the "Color balance Warm" shown in the below table. 17. Set "ALL-DRIVE" to "252". <p>Table 1. Color balance target value</p> <table border="1" data-bbox="220 1346 863 1491"> <thead> <tr> <th>Color Temperature</th> <th>x</th> <th>y</th> </tr> </thead> <tbody> <tr> <td>Cool</td> <td>0.276</td> <td>0.276</td> </tr> <tr> <td>Normal</td> <td>0.288</td> <td>0.296</td> </tr> <tr> <td>Warm</td> <td>0.313</td> <td>0.329</td> </tr> </tbody> </table>		Color Temperature	x	y	Cool	0.276	0.276	Normal	0.288	0.296	Warm	0.313	0.329	<p>Picture menu: Dynamic ASPECT:16:9</p> <p>• Highlight section Signal amplitude 75%</p> <p>1080i White Balance Pattern</p>  <p>* The Color balance COOL differs from Japanese model values.</p>
Color Temperature	x	y												
Cool	0.276	0.276												
Normal	0.288	0.296												
Warm	0.313	0.329												

3.3. Sub bright adjustment

Instrument Name	Connection	Remarks
1. PAL-M or NTSC signal generator (or RF)	Connect to the input terminal	User setting: Normal
Procedure		Remarks
<ul style="list-style-type: none"> • White balance adjustment is finished for each signal. • Do adjustments in a dark room. • Complete the adjustment within 10 minutes after the turn on electricity. <p>Turn on the power supply again when it is not possible to complete it by aging etc.</p> <ol style="list-style-type: none"> 1. Display the 10 step gray-scale pattern for adjusting sub-bright from video input. 2. Use "Sub-Bright" in the <Sevice1> mode to adjust so the 6th section shows up and the 7th fades away. 		Picture menu: Dynamic Color balance: Normal ASPECT: 16:9
Data Sub-Bright data addresses Sub-Bright (upper) A0-0116 Sub-Bright (lower) A0-0117		
<div style="display: flex; justify-content: center; align-items: center; gap: 20px;"> 6th  7th </div> 		

3.4. ABL adjustment

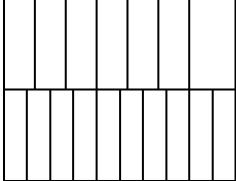
Instrument Name	Connection	Remarks
1. HD signal emitter (or Leader : 1080i/No.9 signal) 2. Wattmeter	COMPONENT input terminal Connect the AC power of the set to the wattmeter.	
Procedure		Remarks
<p> • Make sure the set is aged for 30 minutes or more before adjustment. (Do not switch off during or after aging.) • Voltage 230V 50Hz (variation within 1%) • Volume at minimum and screen size at "16:9" Component input, dynamic, standard </p> <p> 1. Connect the set's AC power to the wattmeter. 2. Input the signal (top half: color bar, Bottom half :Horizontal 10steps bar). 3. Select the "PWRCTL" item in the <Service1> mode. 4. Adjust PWRCTL so the set's power consumption is 289 (+5/-10)W </p> <p> Remarks 1. The initial data are Data address : A0-0102 Default data : 0x00 2. The power and data are in reverse relationship. Data is displayed by 2'C. (Lower the data to raise the power.) • Raising direction (↑): 0→255, 254, 253..... • Lowering direction (↓):0→1, 2, 3..... 3. There is a possibility that the adjustment value can do two places, adjust it in that case, that the value of PWRCTL is large. </p> <div style="display: flex; align-items: center; margin-top: 20px;">  <div style="margin-left: 20px;"> <p>No.9 Signal Top half: Full color bar Bottom half: Horizontal 10 steps bar</p> </div> </div>		

3.5. Sub-Contrast adjustment

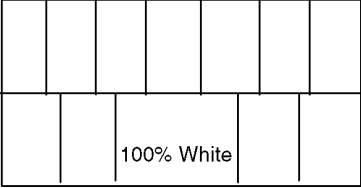
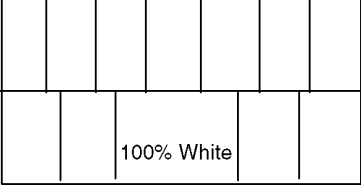
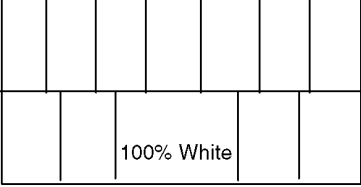
Name of measuring instrument	Connection	Remarks
RF generator Base Band generator		
Adjustment of AV system		Remarks
<p>1. Receive AV1 (PAL-M or NTSC 100% Full White or Split Colour bar shown as below).</p> <div style="text-align: center; margin: 10px 0;">  </div> <p>2. Goes into service mode, choose Sub-Contrast, and it checks that data value is 512. (It checks that an initial value is a default)</p> <p>3. The colour key yellow button of remote control is pushed.</p> <p>4. The OSD character of sub-contrast becomes red. (Inside under automatic adjustment)</p> <p>5. The OSD character of sub-contrast returns to white.</p> <p>6. End.</p>		
Adjustment of RF system		Remarks
<p>1. Receive a RF. (PAL-M or NTSC 100% Full White or Split Colour bar shown as below).</p> <div style="text-align: center; margin: 10px 0;">  </div> <p>2. Goes into service mode, choose Sub-Contrast, and it checks that data value is 512. (It checks that an initial value is a default)</p> <p>3. The colour key yellow button of remote control is pushed.</p> <p>4. The OSD character of sub-contrast becomes red. (Inside under automatic adjustment)</p> <p>5. The OSD character of sub-contrast returns to white.</p> <p>6. End.</p>		
Adjustment of HD system		Remarks
<p>1. Recieve Component (1080i/ 60Hz or 1080i/ 50Hz, 100% Full White or Split colour bar as shown below).</p> <div style="text-align: center; margin: 10px 0;">  </div> <p>2. Goes into service mode, choose Sub-Contrast, and it checks that data value is 384. (It checks that an initial value is a default)</p> <p>3. The colour key yellow button of remote control is pushed.</p> <p>4. The OSD character of sub-contrast becomes red. (Inside under automatic adjustment)</p> <p>5. The OSD character of sub-contrast returns to white.</p> <p>6. End.</p>		

4 Conductor Views

4.1. TU-Board

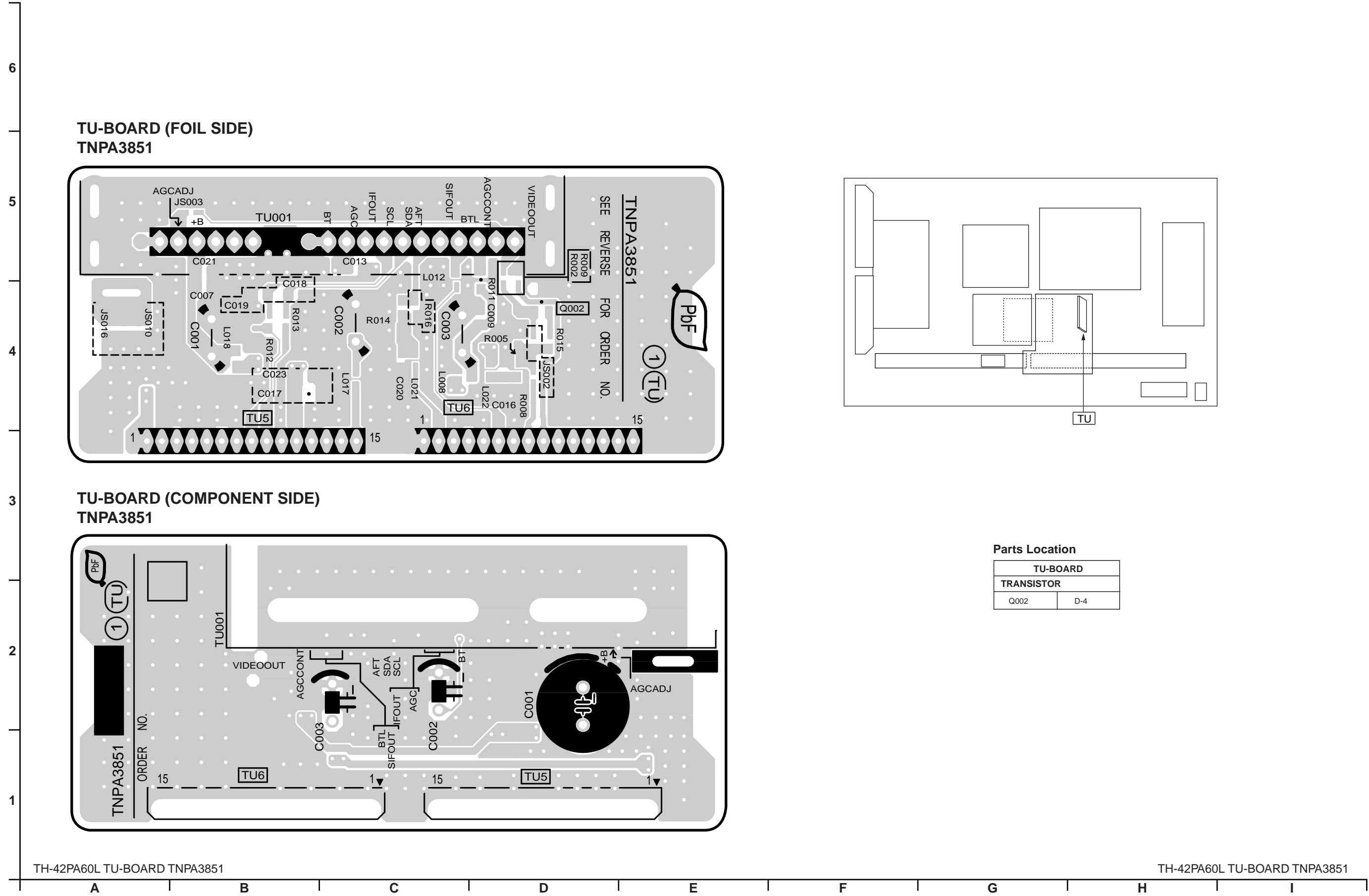

TU-BOARD (FOIL SIDE)
TNPA3851

TU-BOARD (COMPONENT SIDE)
TNPA3851

Parts Location

TU-BOARD	
TRANSISTOR	
Q002	D-4

4.2. DG-Board

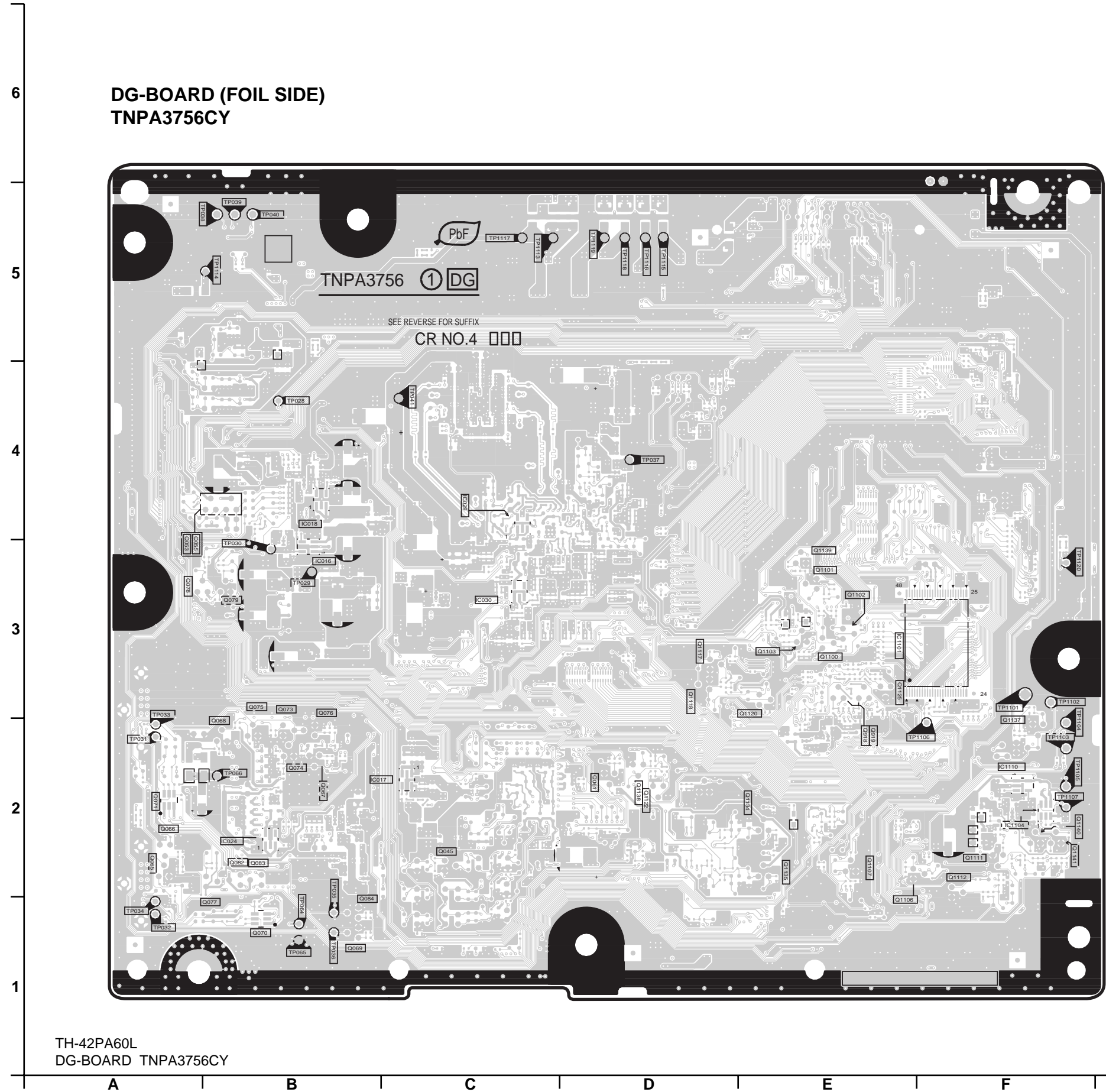

TH-42PA60L
DG-BOARD TNPA3756CY

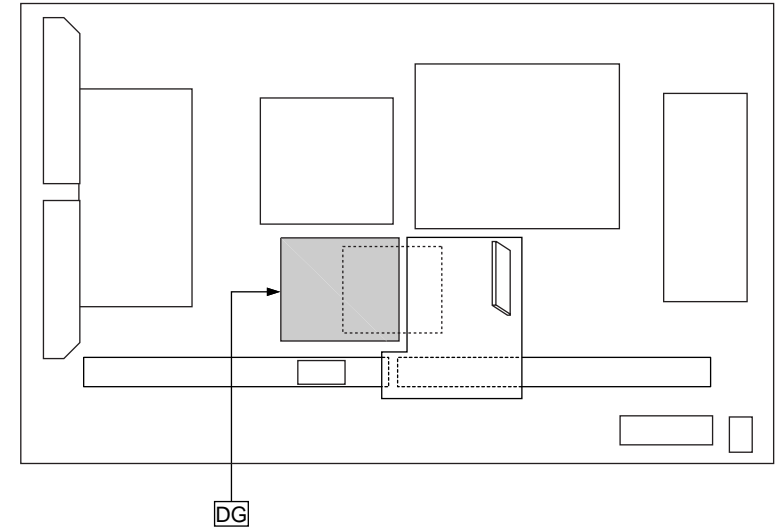

Parts Location

DG-BOARD (FOIL SIDE)					
IC		Q4045		TP	
IC1101	E-3	Q4053	C-2	TP1101	F-3
IC1104	F-2	Q4055	A-3	TP1102	F-3
IC1110	F-2	Q4061	D-2	TP1103	F-2
IC4016	B-3	Q4065	A-2	TP1104	F-2
IC4017	B-2	Q4066	A-2	TP1105	F-2
IC4018	B-4	Q4067	B-2	TP1106	F-2
IC4024	B-2	Q4068	B-2	TP1107	F-2
IC4029	C-4	Q4069	B-1	TP1113	C-5
IC4030	C-3	Q4070	B-1	TP1114	B-5
		Q4071	A-2	TP1115	D-5
		Q4073	B-3	TP1116	D-5
		Q4074	B-2	TP1117	C-5
		Q4075	B-3	TP1118	D-5
		Q4076	B-3	TP1119	D-5
		Q4077	B-1	TP1120	F-3
		Q4078	A-3	TP4028	B-4
		Q4079	B-3	TP4029	B-3
		Q4082	B-2	TP4030	B-3
		Q4083	B-2	TP4031	A-2
		Q4084	B-1	TP4032	A-4
		Q4918	E-2	TP4033	A-3
		Q4919	E-2	TP4034	A-1
				TP4035	B-1
				TP4036	B-1
				TP4037	D-4
				TP4038	B-5
				TP4039	B-5
				TP4040	B-5
				TP4041	C-4
				TP4064	B-1
				TP4065	B-1
				TP4066	B-2
TRANSISTOR					
Q1100	E-3				
Q1101	E-3				
Q1102	E-3				
Q1103	E-3				
Q1106	E-1				
Q1107	E-2				
Q1111	F-2				
Q1112	F-2				
Q1117	D-3				
Q1118	D-3				
Q1120	E-3				
Q1122	D-2				
Q1125	E-3				
Q1134	E-2				
Q1135	F-2				
Q1137	F-2				
Q1138	D-2				
Q1139	E-3				
Q1140	F-2				
Q1141	F-2				

TH-42PA60L
DG-BOARD TNPA3756CY

6
5
4
3
2
1

DG-BOARD (COMPONENT SIDE)
TNPA3756CY

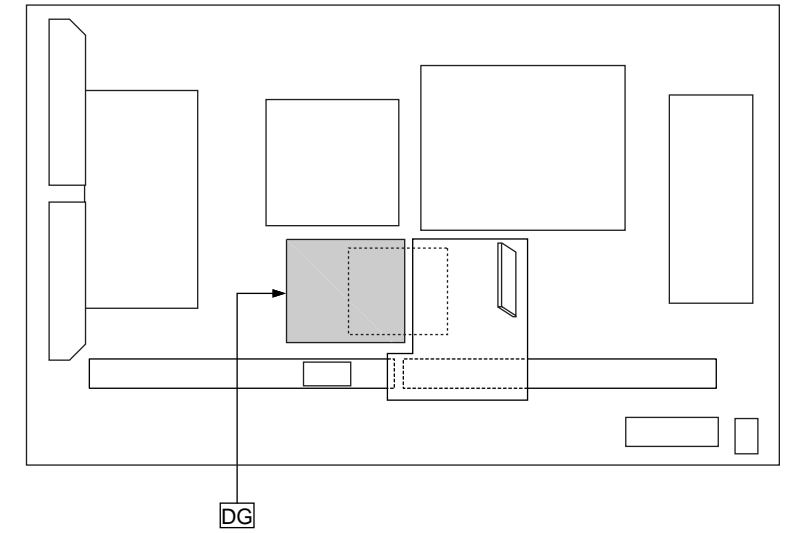
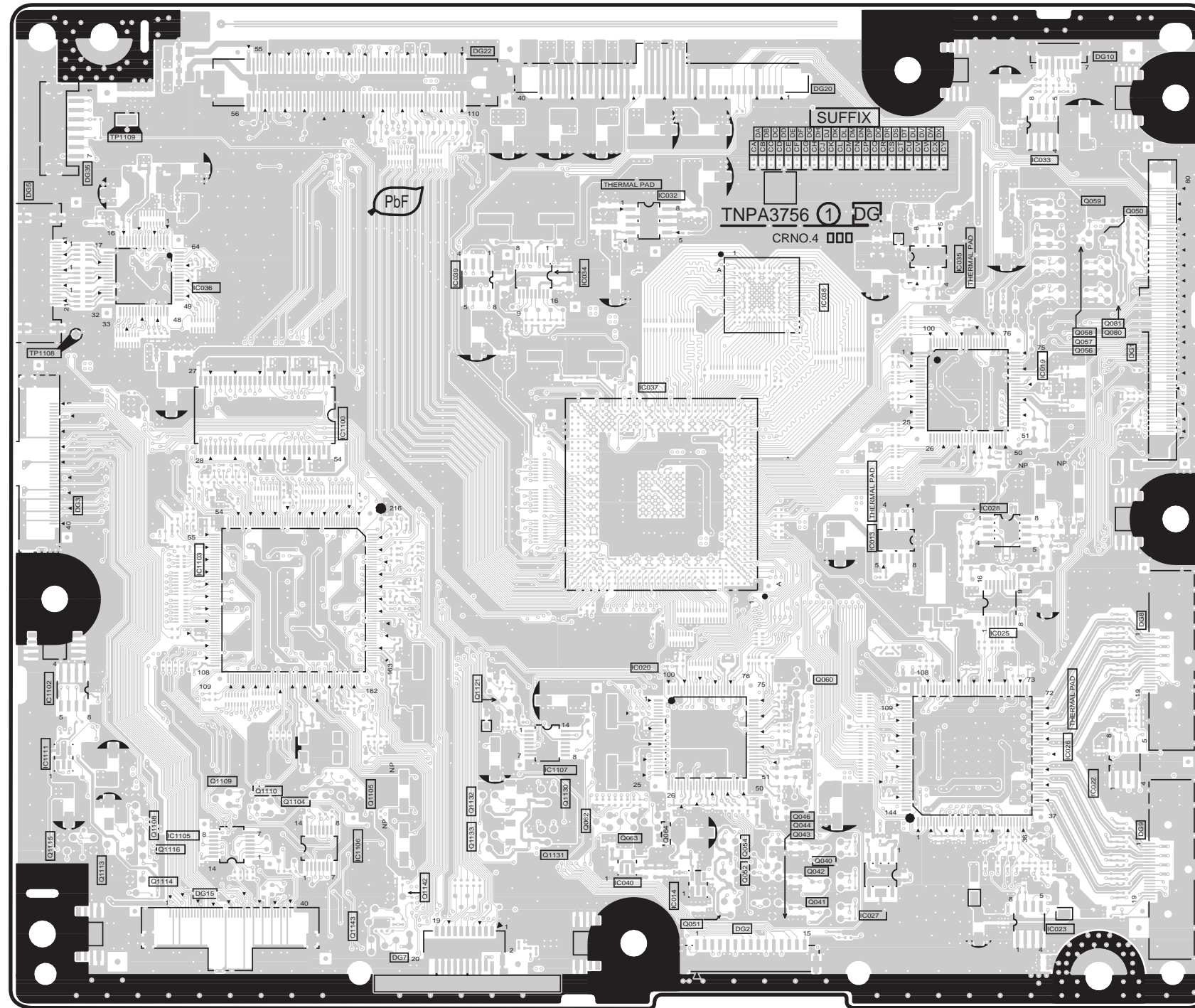

Parts Location

DG-BOARD (COMPONENT SIDE)					
IC	TRANSISTOR			Q4056	F-4
IC1100	C-4	Q1104	B-2	Q4057	F-4
IC1102	A-2	Q1105	C-2	Q4058	F-4
IC1103	B-3	Q1108	B-2	Q4059	F-5
IC1105	B-2	Q1109	B-2	Q4060	E-2
IC1106	C-2	Q1110	B-2	Q4062	D-2
IC1107	D-2	Q1113	A-2	Q4063	D-2
IC1111	A-2	Q1114	B-2	Q4064	D-2
IC4013	E-3	Q1115	A-2	Q4080	F-4
IC4014	D-1	Q1116	B-2	Q4081	F-4
IC4019	F-4	Q1121	C-2	TP	
IC4020	D-3	Q1130	D-2		
IC4022	F-2	Q1131	D-2	TP1108	A-4
IC4023	F-1	Q1132	C-2	TP1109	A-5
IC4025	F-3	Q1133	C-2		
IC4026	F-2	Q1142	C-1		
IC4027	E-1	Q1143	C-1		
IC4028	F-3	Q4040	E-2		
IC4032	D-5	Q4041	E-1		
IC4033	F-5	Q4042	E-2		
IC4034	D-4	Q4043	E-2		
IC4035	E-4	Q4044	E-2		
IC4036	B-4	Q4046	E-2		
IC4037	D-4	Q4050	F-5		
IC4038	E-4	Q4051	D-1		
IC4039	C-4	Q4052	D-2		
IC4040	D-2	Q4054	D-2		

TH-42PA60L
DG-BOARD TNPA3756CY

TH-42PA60L
DG-BOARD TNPA3756CY

A B C D E F G H I

5 Schematic and Block Diagram

5.1. Schematic Diagram Note

Important Safety Notice

Components identified by \triangle mark have special characteristics important for safety. When replacing any of these components, use only manufacture's specified parts.

Notes:

1. **Resistor**
Unit of resistance is OHM [Ω] (K=1,000, M=1,000,000).
2. **Capacitor**
Unit of capacitance is μ F, unless otherwise noted.
3. Coil
Unit of inductance is H, unless otherwise noted.
4. Test Point
○ : Test Point position
5. Earth Symbol
⏏ : Chassis Earth (Cold) ⚡ : Line Earth (Hot)
6. Voltage Measurement
Voltage is measured by a DC voltmeter.
Conditions of the measurement are the following:
Power Source AC110-220V, 50/60Hz
Receiving Signal Colour Bar signal (RF)
All customer's controls Maximum positions
7. When arrow mark (↗) is found, connection is easily found from the direction of arrow.
8. Indicates the major signal flow. : Video ➡ Audio ⇔
9. This schematic diagram is the latest at the time of printing and subject to change without notice.

Remarks:

1. The Power Circuit contains a circuit area which uses a separate power supply to isolate the earth connection.
The circuit is defined by HOT and COLD indications in the schematic diagram. Take the following precautions.
All circuits, except the Power Circuit, are cold.
Precautions
 - a. Do not touch the hot part or the hot and cold parts at the same time or you may be shocked.
 - b. Do not short- circuit the hot and cold circuits or a fuse may blow and parts may break.
 - c. Do not connect an instrument, such as an oscilloscope, to the hot and cold circuits simultaneously or a fuse may blow.
Connect the earth of instruments to the earth connection of the circuit being measured.
 - d. Make sure to disconnect the power plug before removing the chassis.

5.2. Main Block Diagram

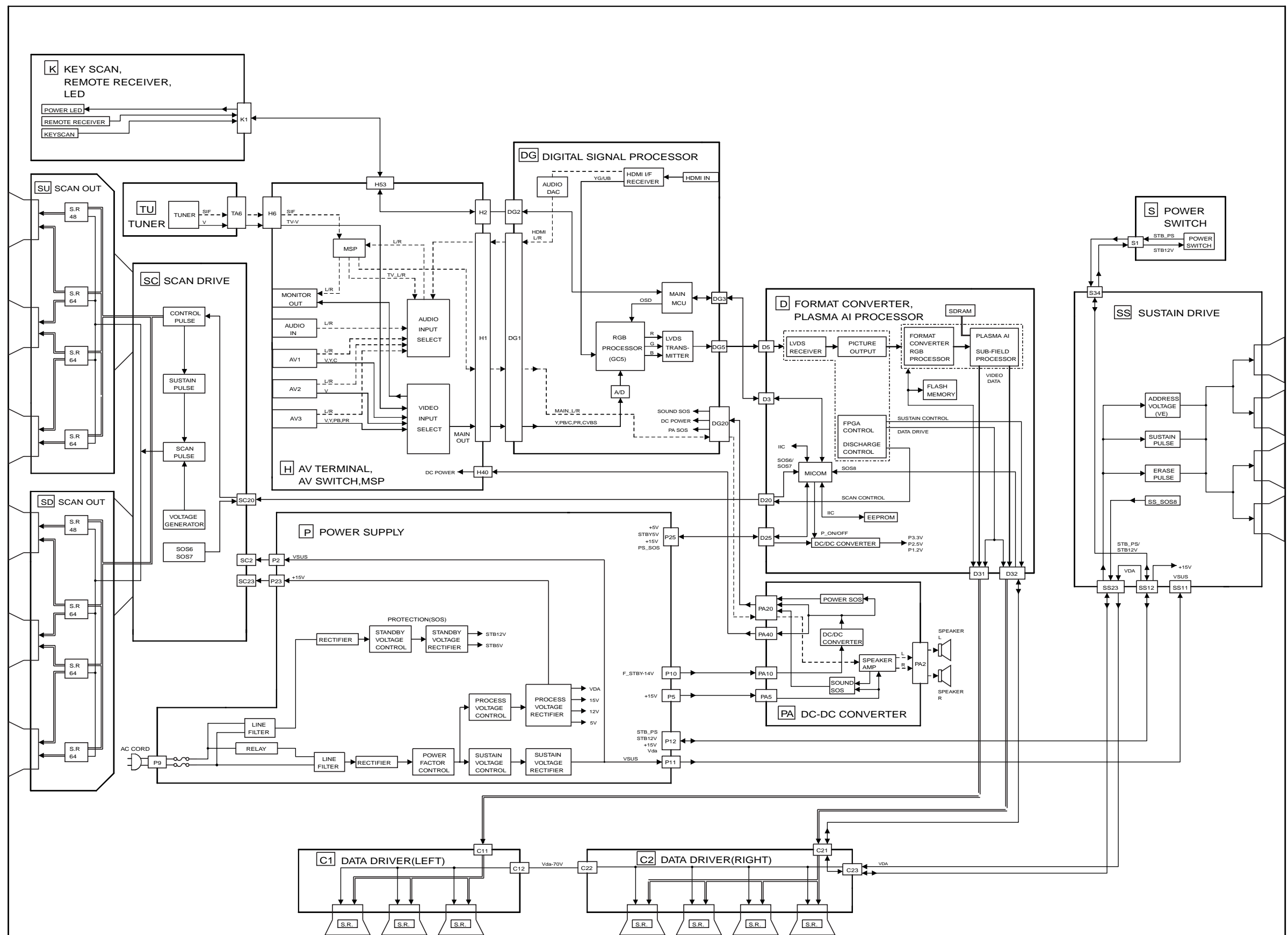

TH-42PA60L Main Block Diagram

TH-42PA60L Main Block Diagram

5.3. TU-Board Block and Schematic Diagram

A
B
C
D
E

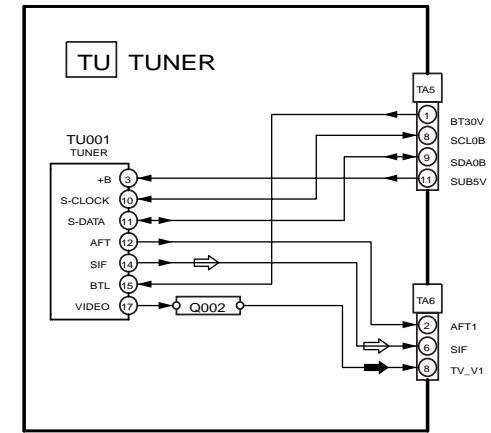
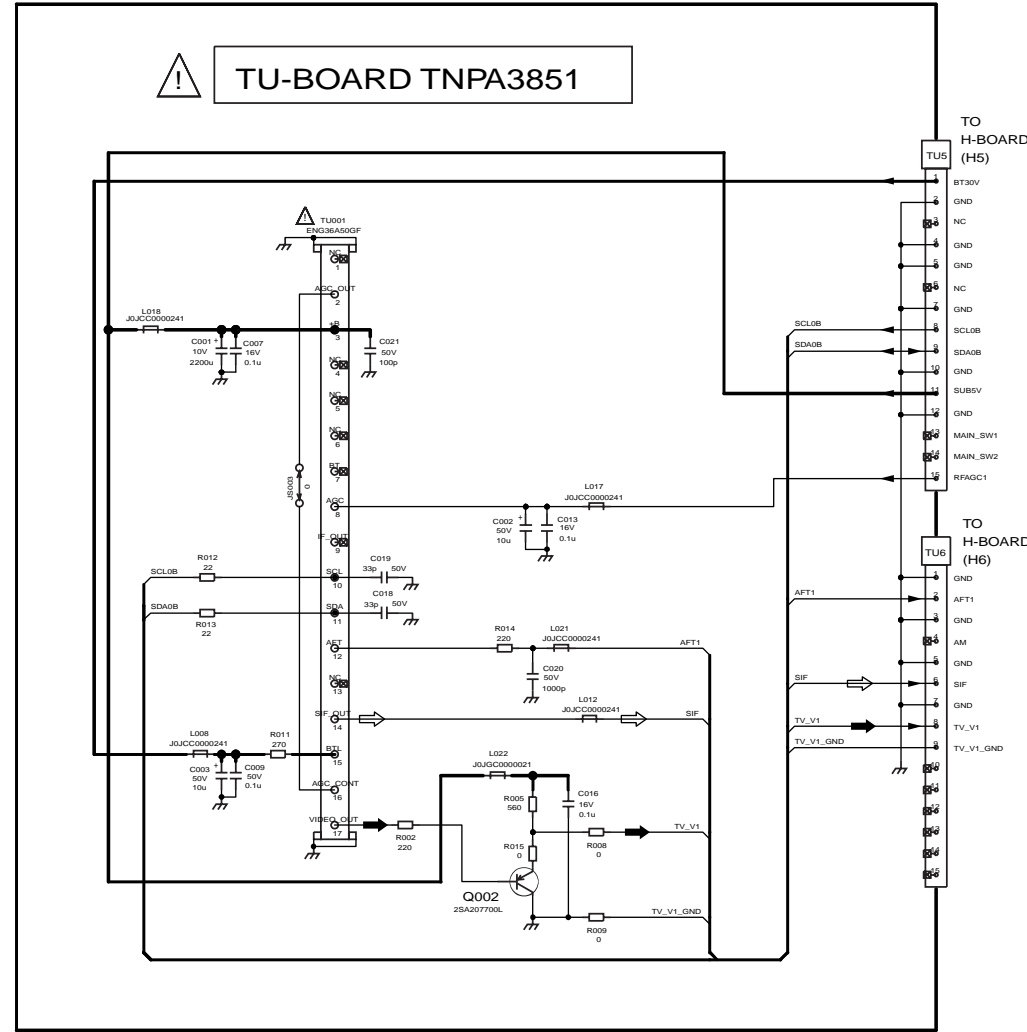

TH-42PA60L TU-Board Block and Schematic Diagram

TH-42PA60L TU-Board Block and Schematic Diagram

1 2 3 4 5 6 7 8

5.4. DG-Board (1 of 3) Block Diagram

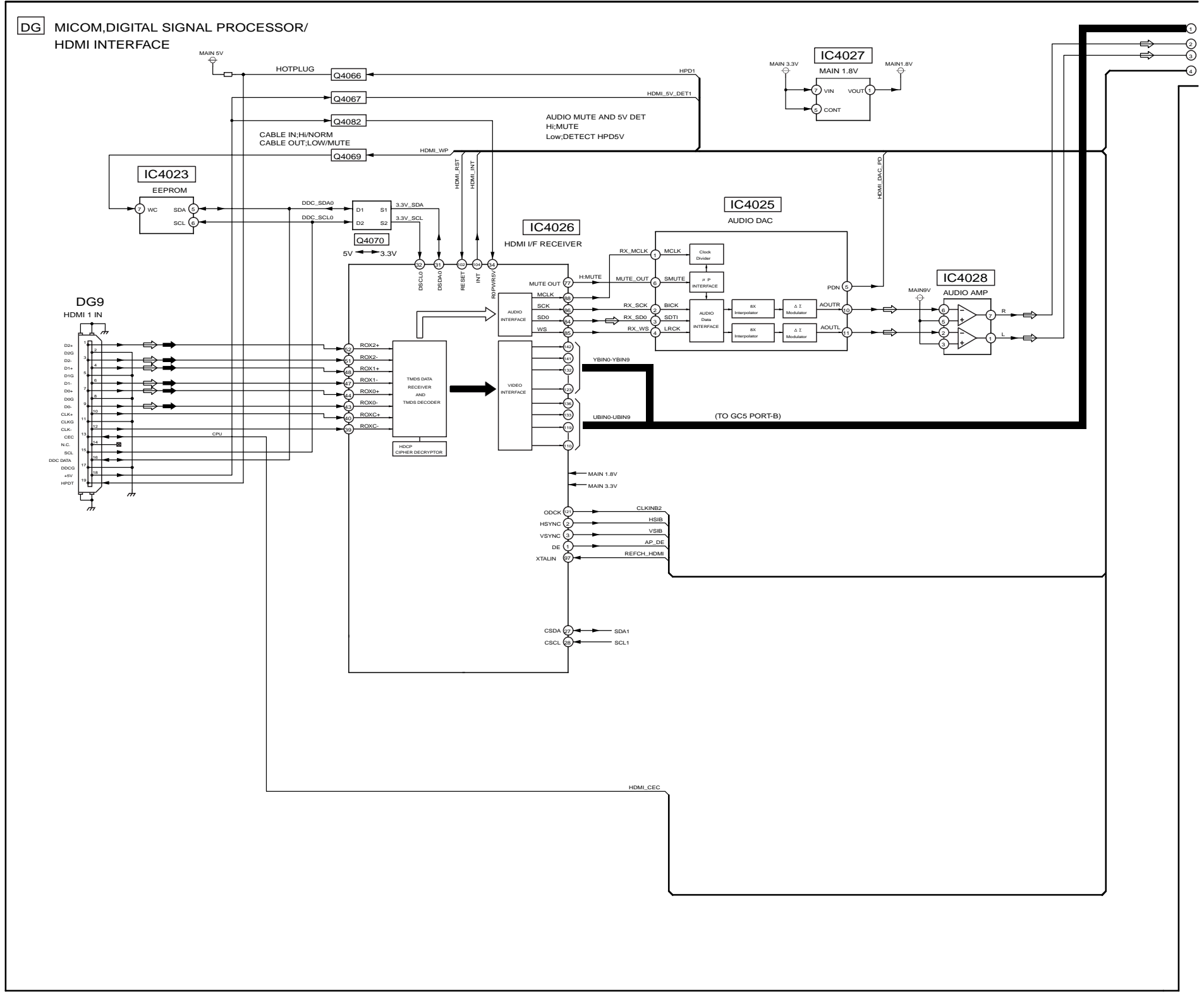

5.5. DG-Board (2 of 3) Block Diagram

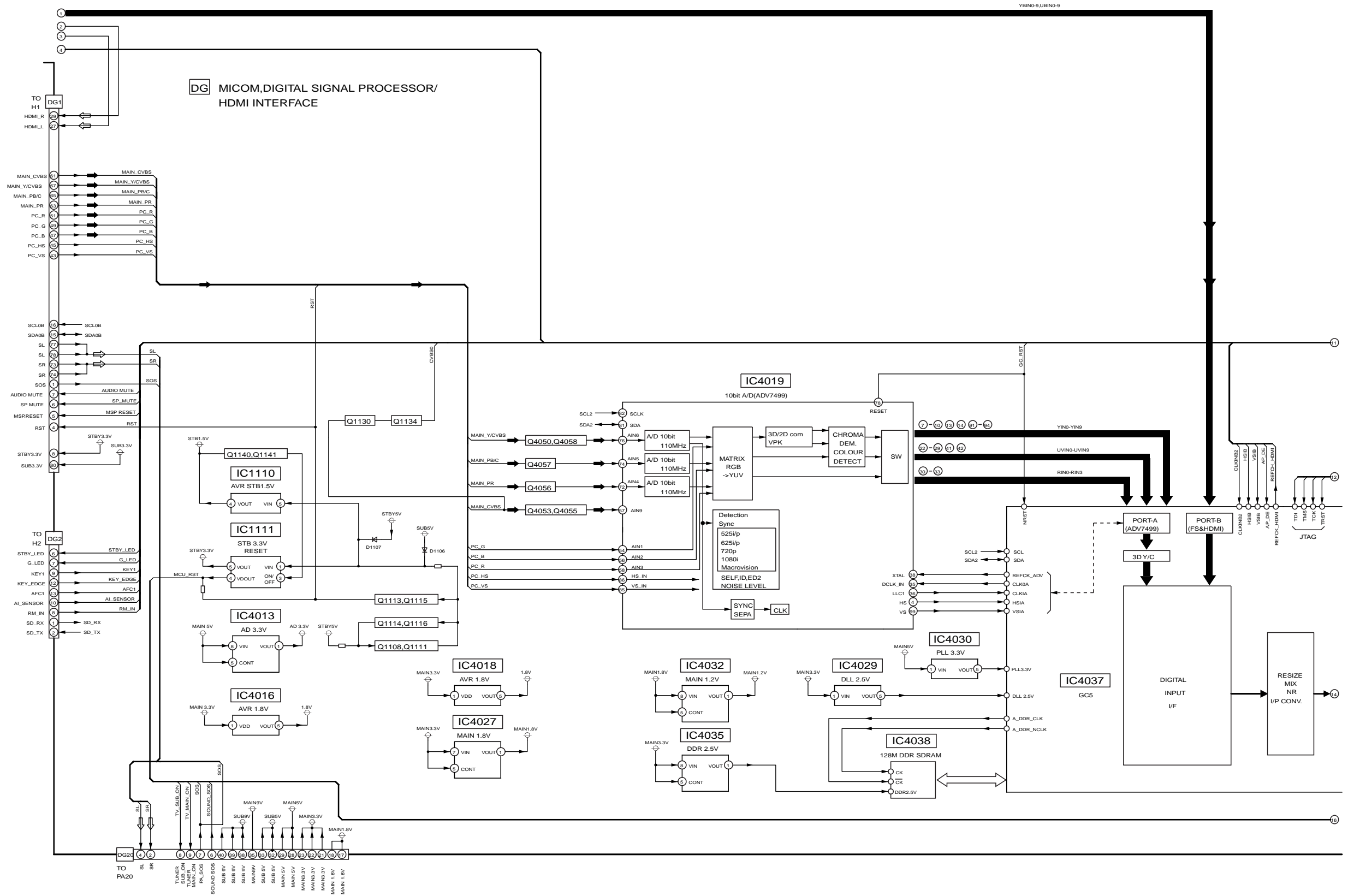

TH-42PA60L
DG-Board (2 of 3) Block Diagram

TH-42PA60L
DG-Board (2 of 3) Block Diagram

5.6. DG-Board (3 of 3) Block Diagram

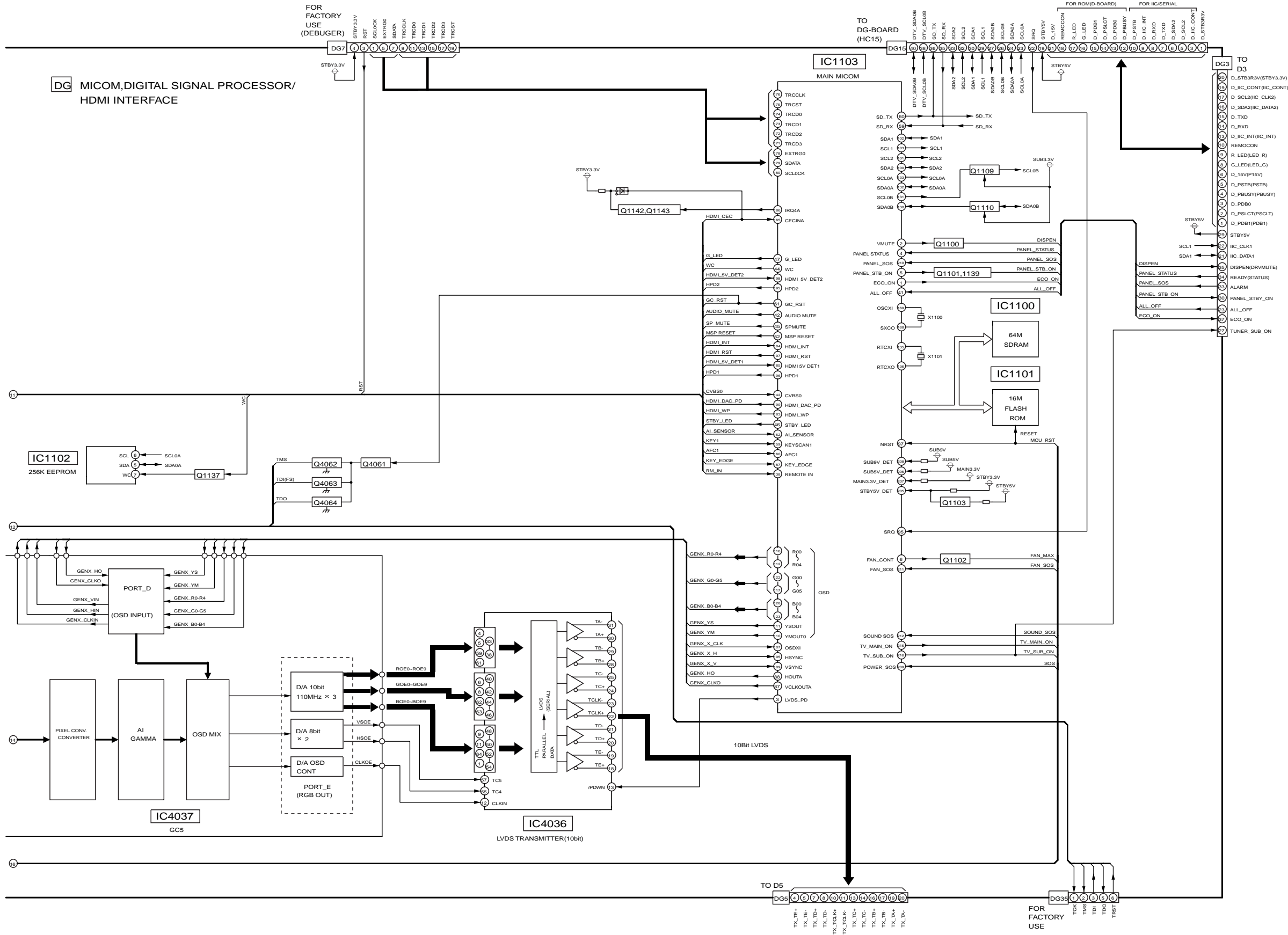

TH-42PA60L
DG-BOARD (3 of 3) Block Diagram

TH-42PA60L
DG-BOARD (3 of 3) Block Diagram

5.7. DG-Board (1 of 8) Schematic Diagram

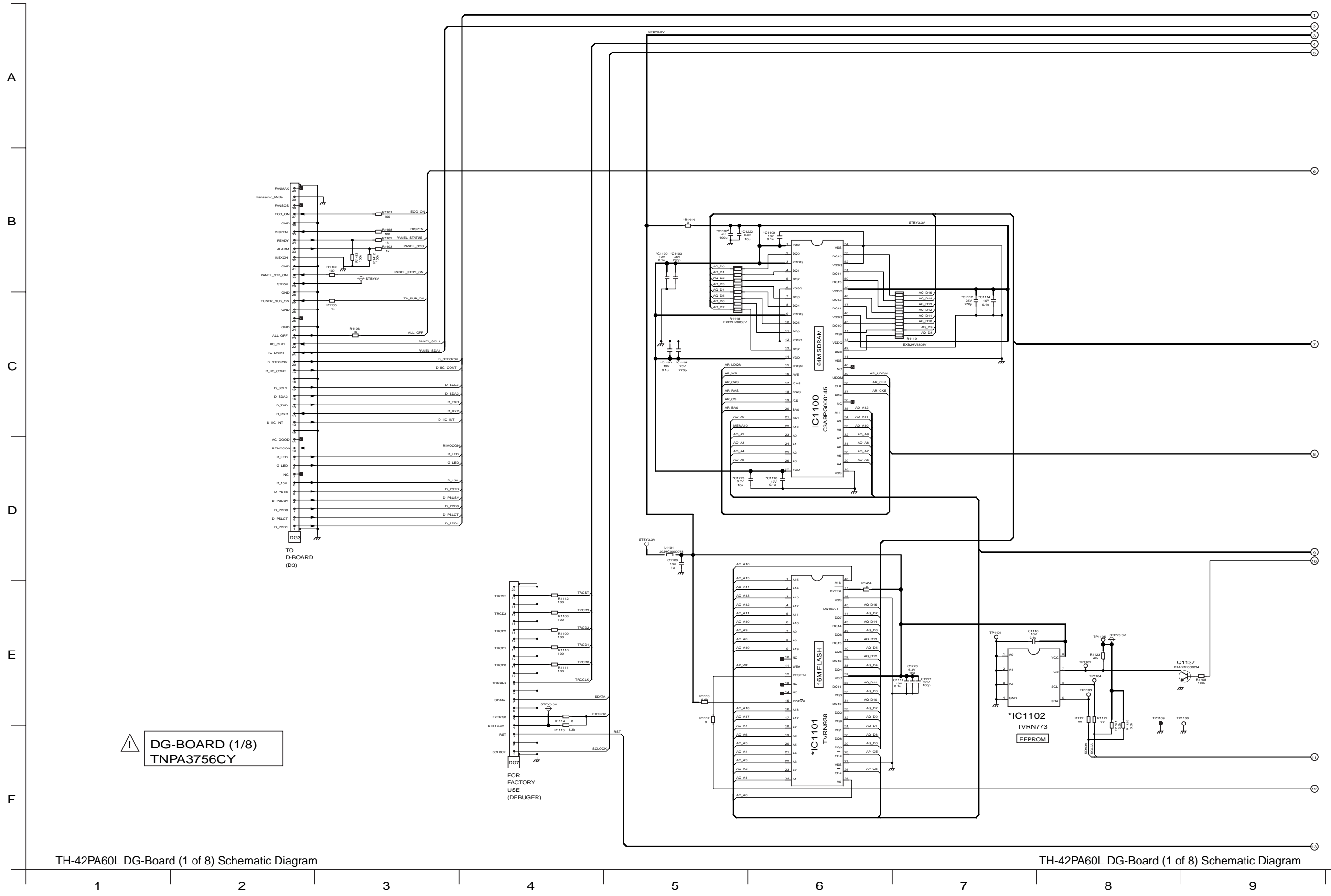

TH-42PA60L DG-Board (1 of 8) Schematic Diagram

TH-42PA60L DG-Board (1 of 8) Schematic Diagram

5.8. DG-Board (2 of 8) Schematic Diagram

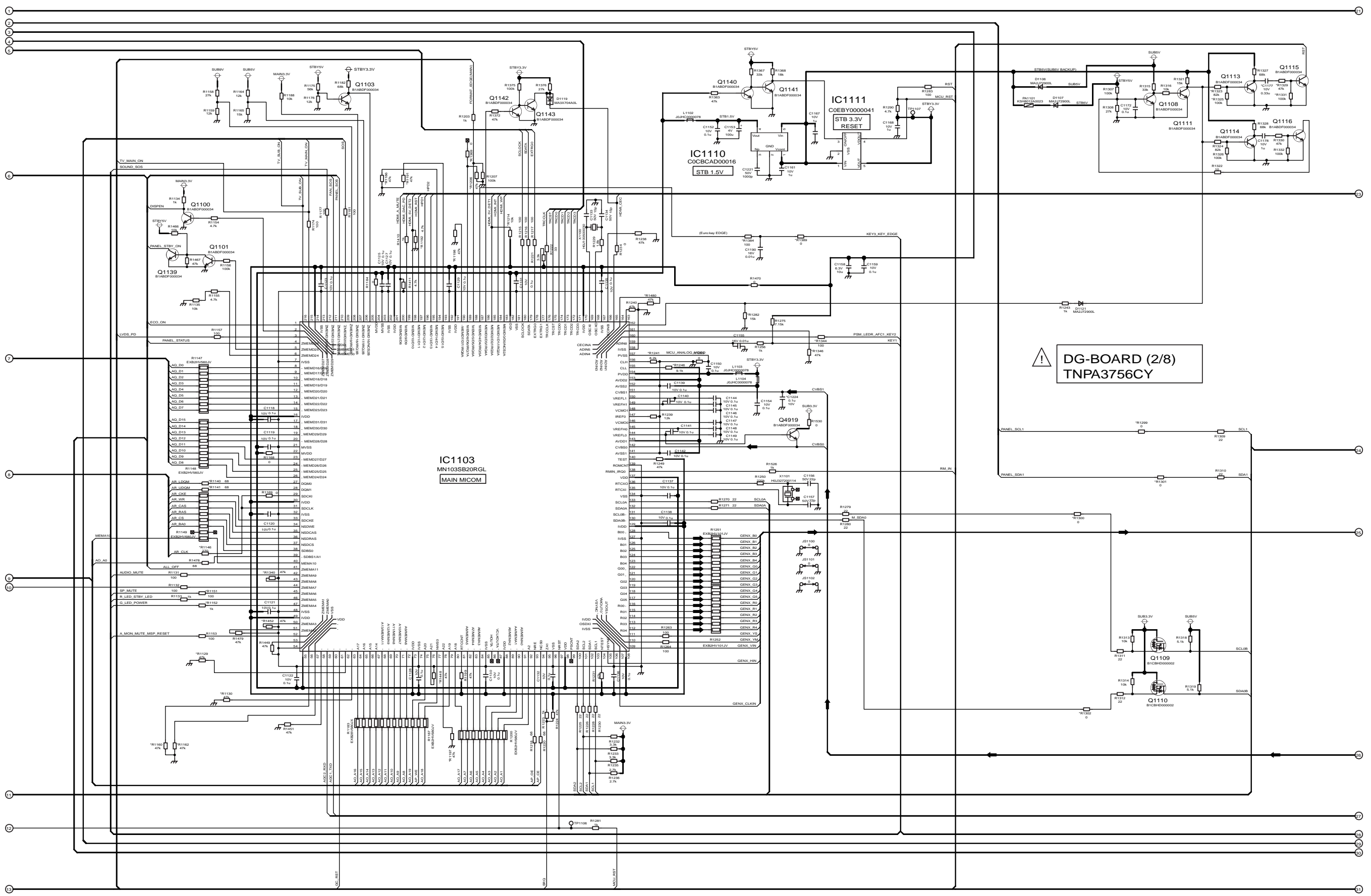

TH-42PA60L DG-Board (2 of 8) Schematic Diagram

TH-42PA60L DG-Board (2 of 8) Schematic Diagram

10

11

12

13

14

15

16

17

18

5.9. DG-Board (3 of 8) Schematic Diagram

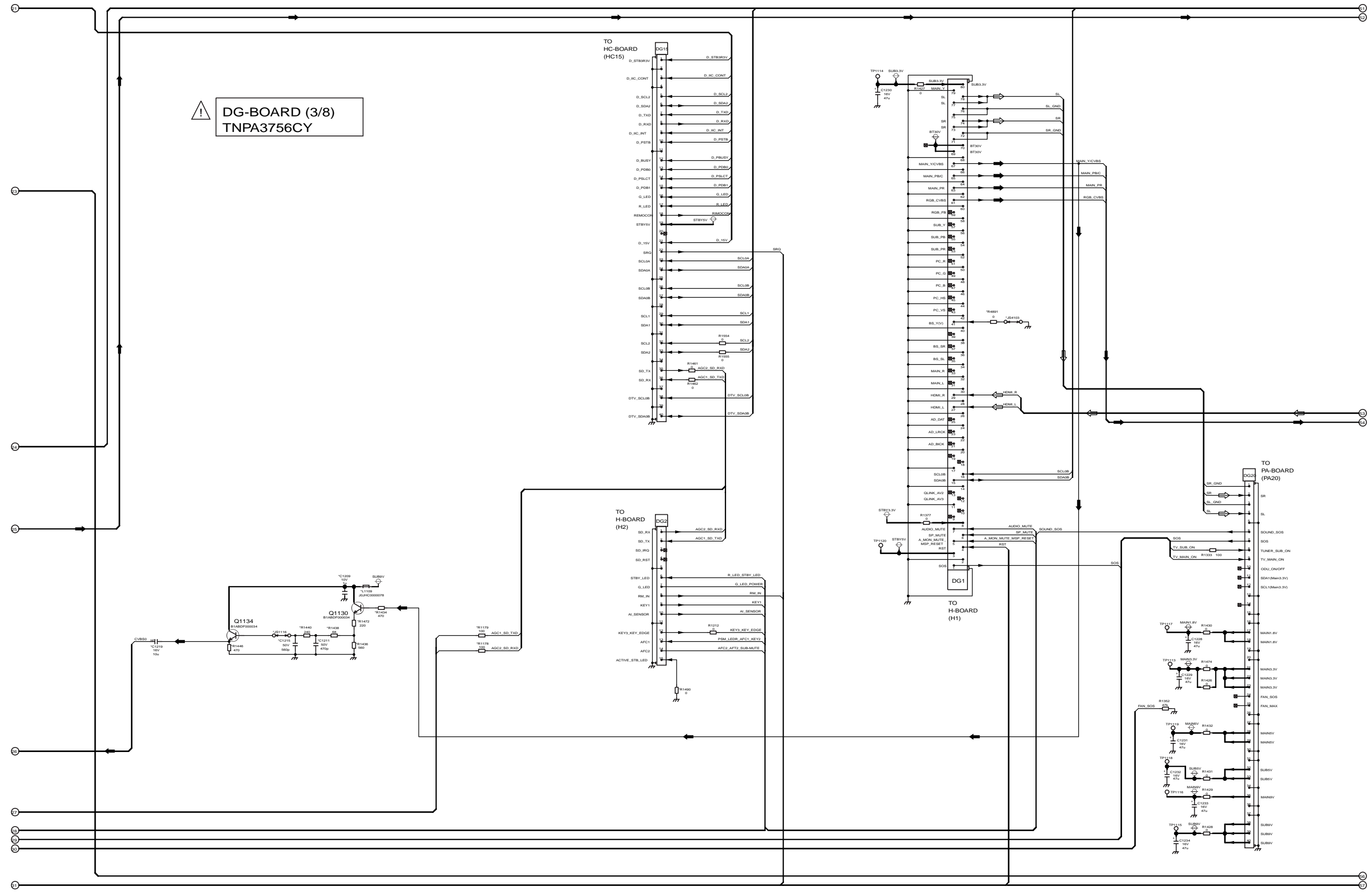

TH-42PA60L DG-Board (3 of 8) Schematic Diagram

TH-42PA60L DG-Board (3 of 8) Schematic Diagram

19 20 21 22 23 24 25 26 27

5.10. DG-Board (4 of 8) Schematic Diagram

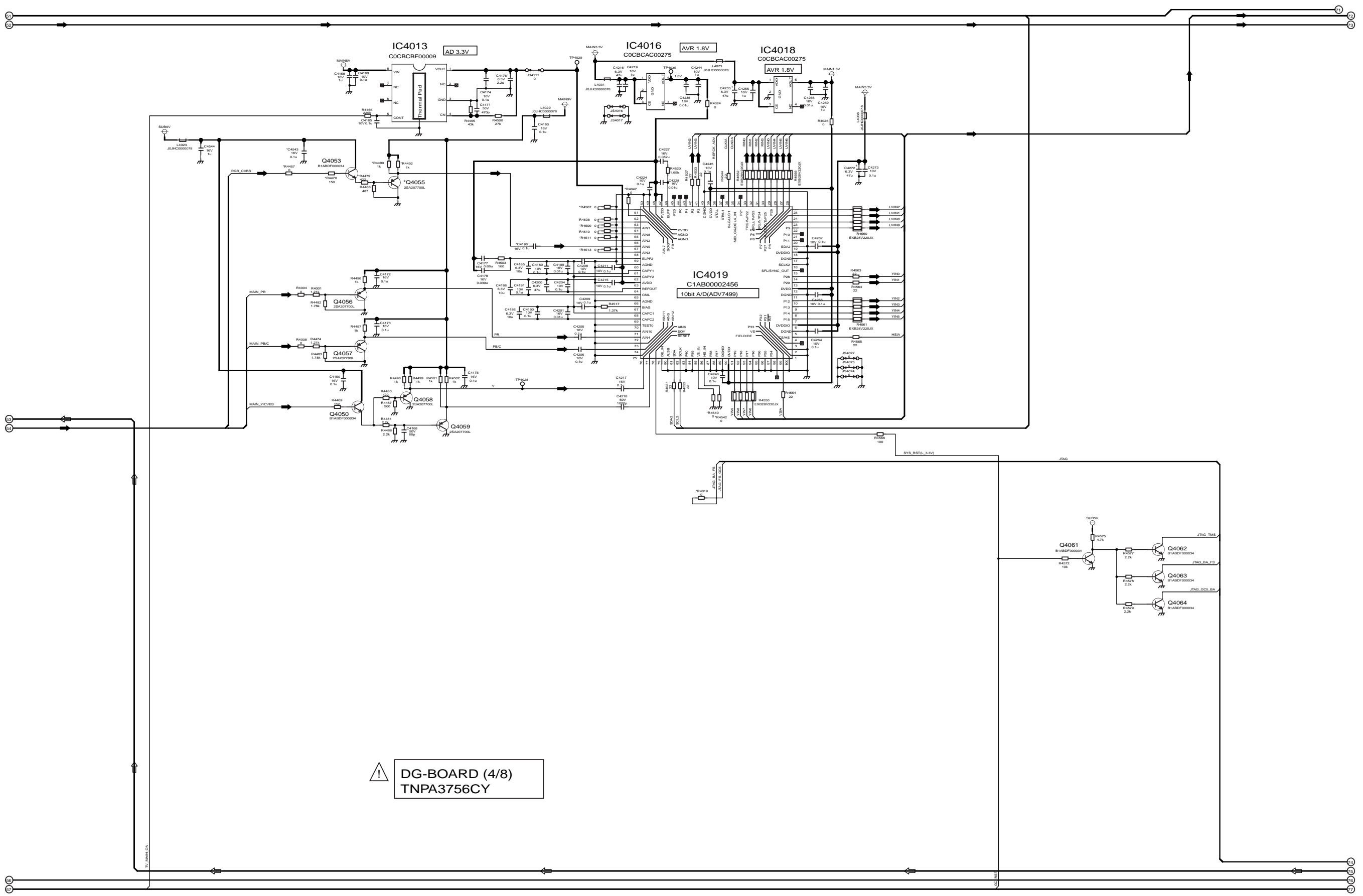

TH-42PA60L DG-Board (4 of 8) Schematic Diagram

TH-42PA60L DG-Board (4 of 8) Schematic Diagram

5.11. DG-Board (5 of 8) Schematic Diagram

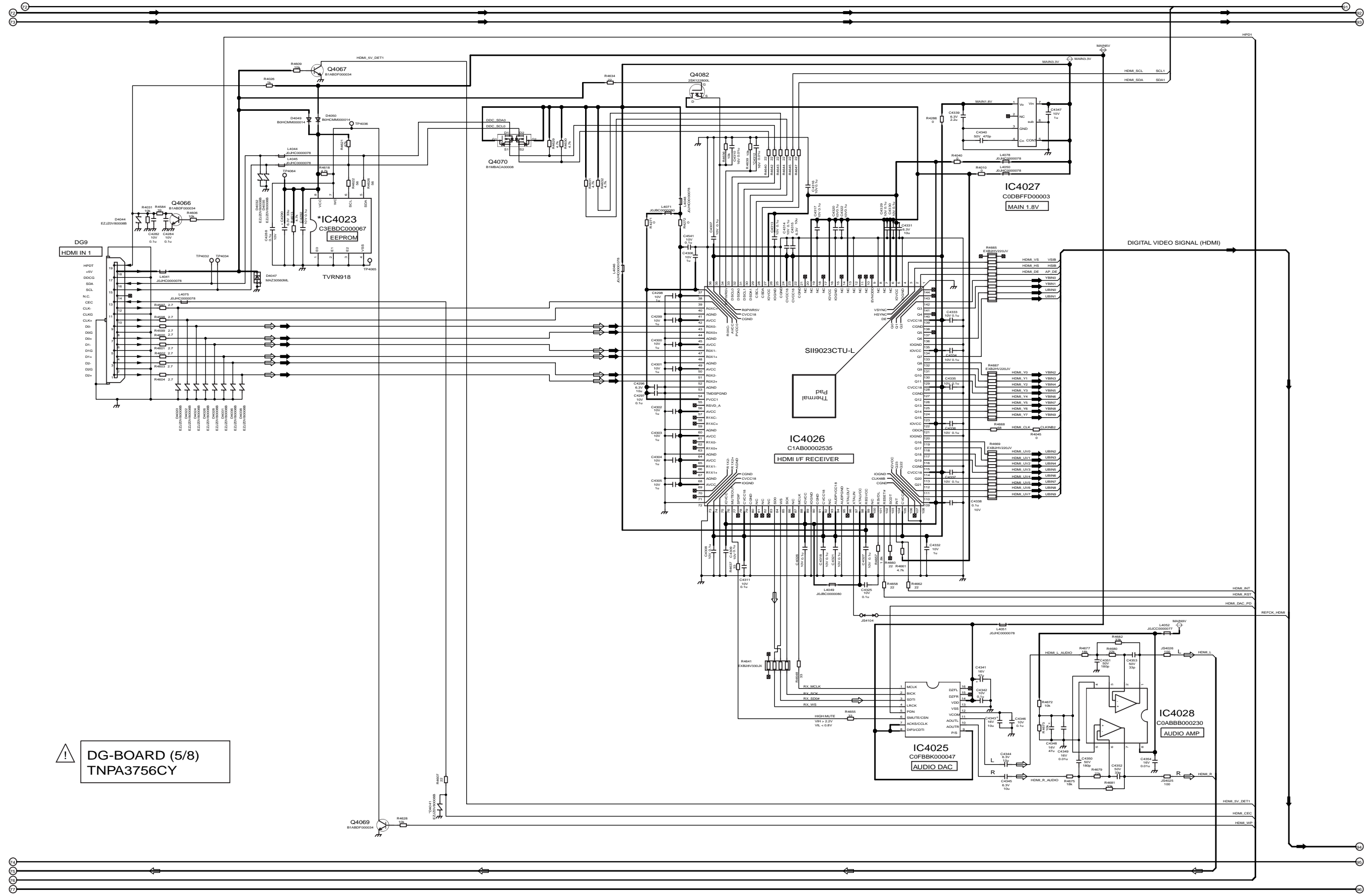

⚠ DG-BOARD (5/8)
TNPA3756CY

TH-42PA60L DG-Board (5 of 8) Schematic Diagram

TH-42PA60L DG-Board (5 of 8) Schematic Diagram

37

38

39

40

41

42

43

44

45

5.12. DG-Board (6 of 8) Schematic Diagram

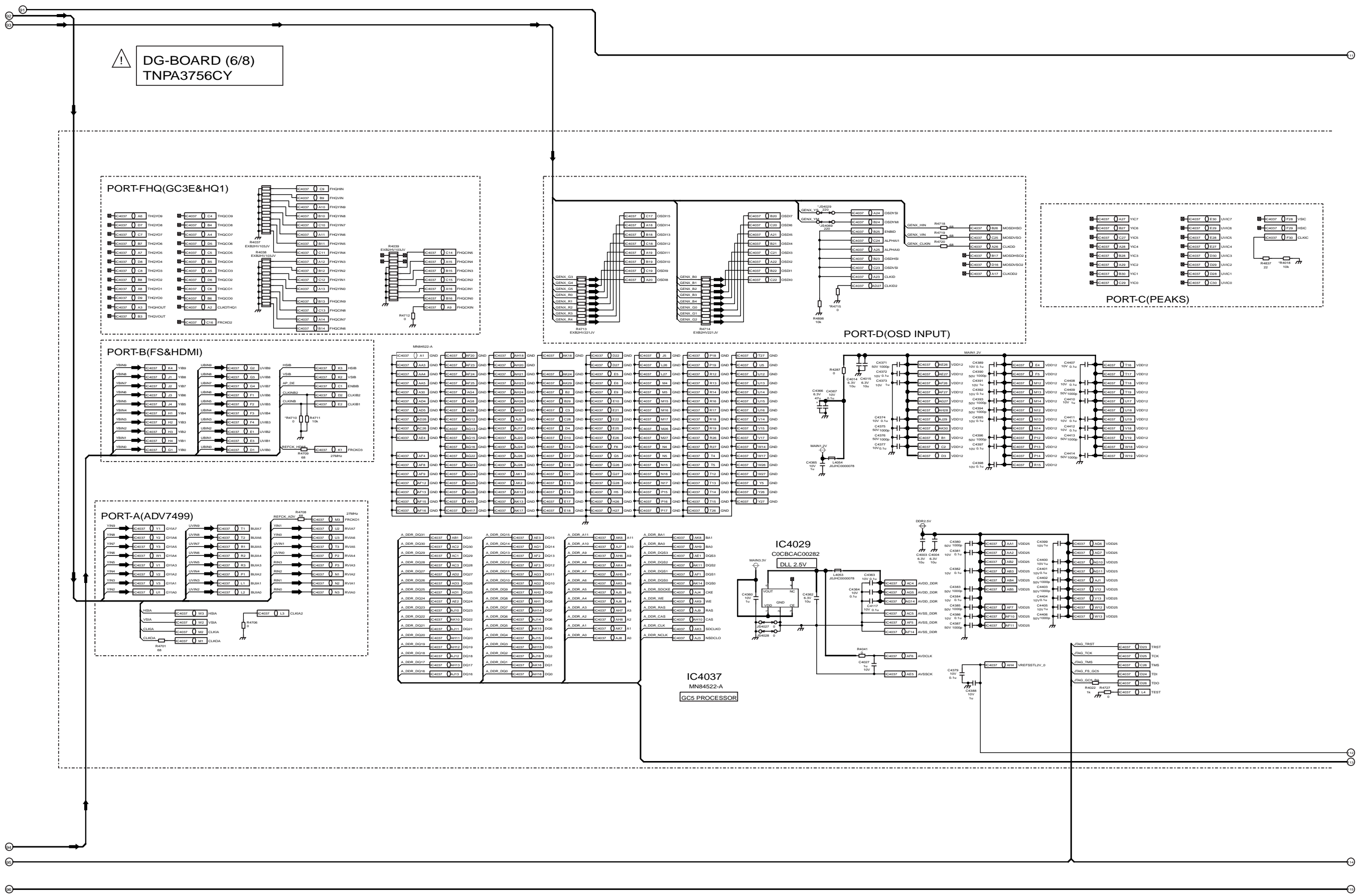

TH-42PA60L DG-Board (6 of 8) Schematic Diagram

TH-42PA60L DG-Board (6 of 8) Schematic Diagram

5.13. DG-Board (7 of 8) Schematic Diagram

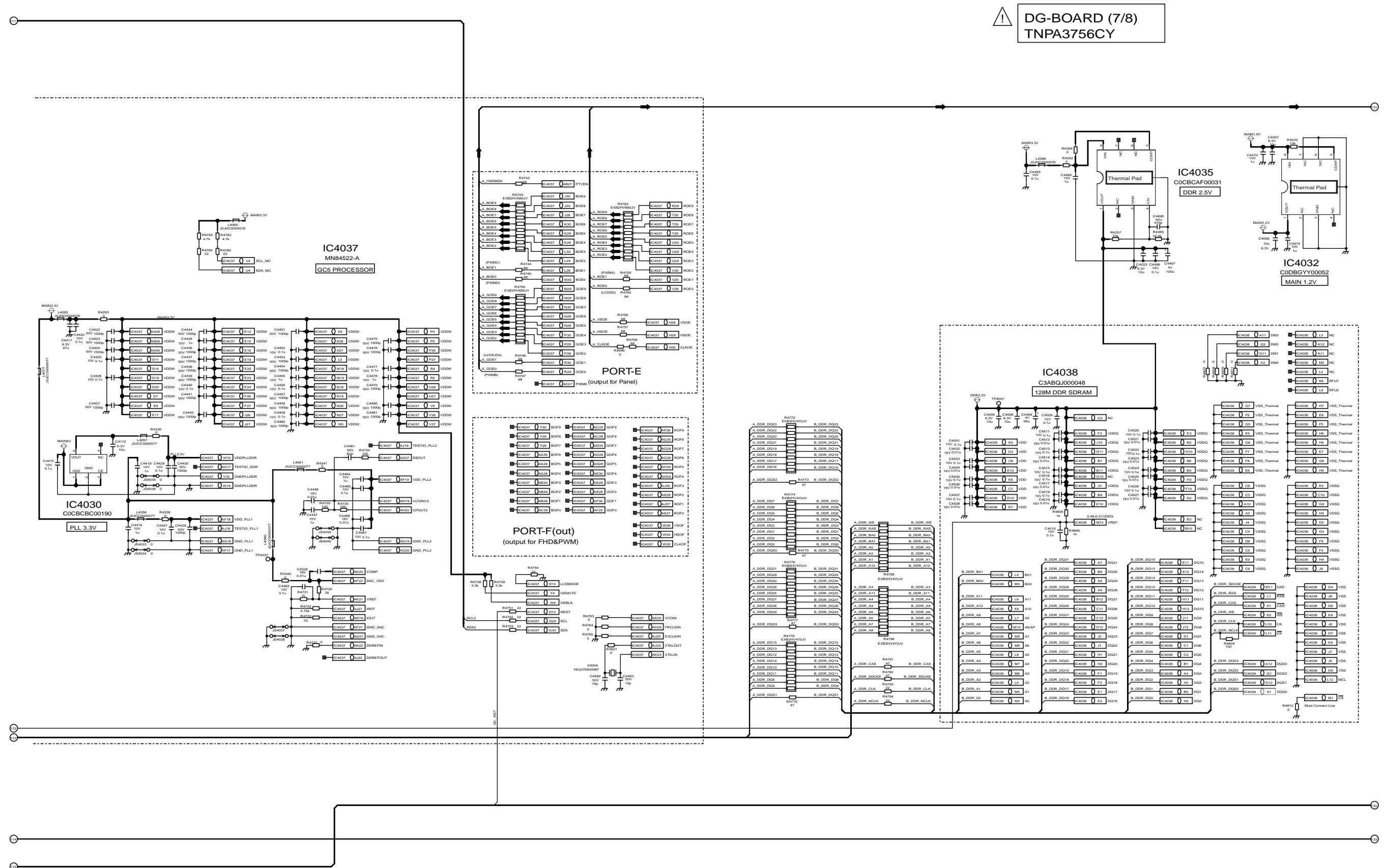

TH-42PA60L DG-Board (7 of 8) Schematic Diagram

TH-42PA60L DG-Board (7 of 8) Schematic Diagram

55

56

57

58

59

60

61

62

63

5.14. DG-Board (8 of 8) Schematic Diagram

DG-BOARD (8/8)
TNPA3756CY

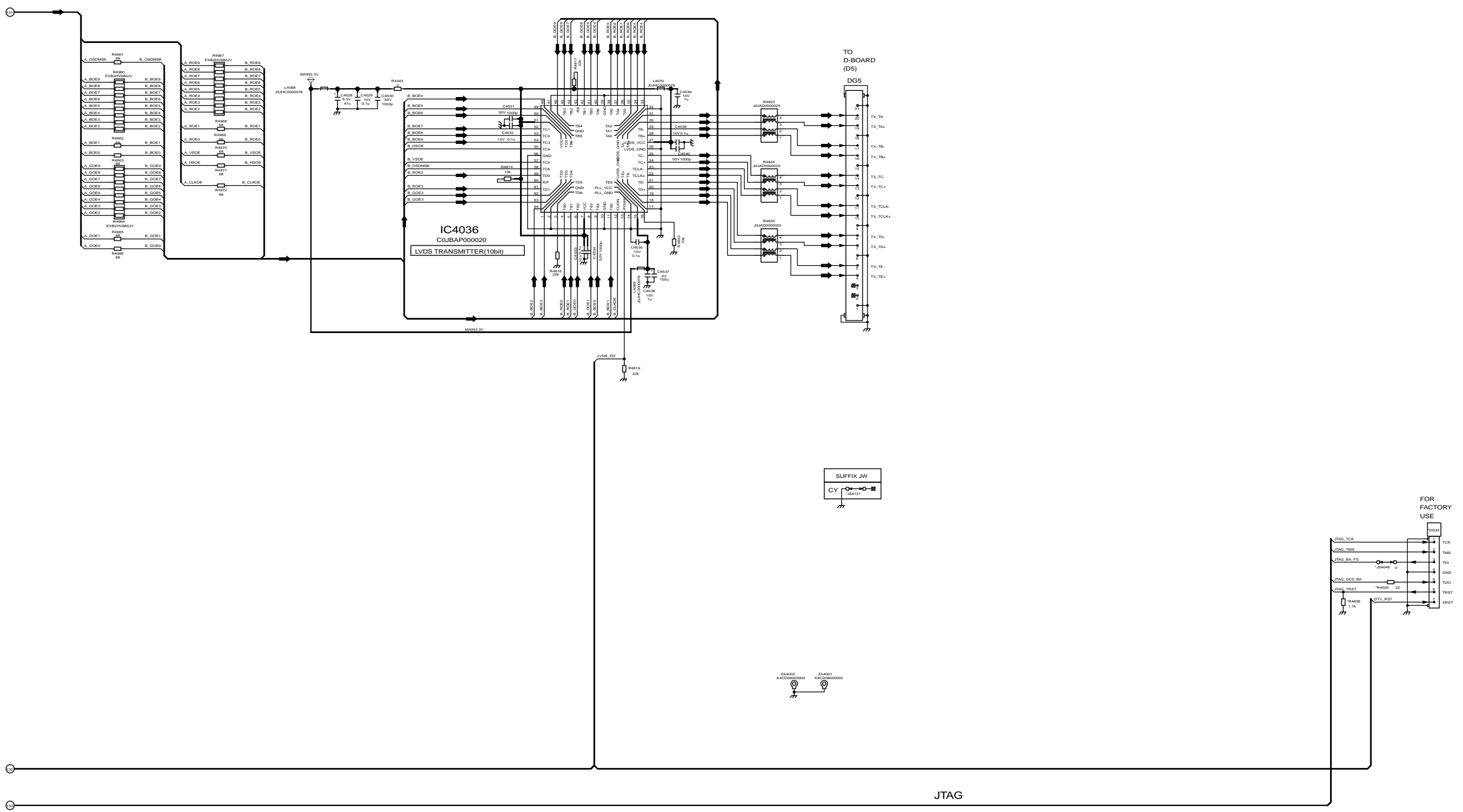

TH-42PA60L DG-Board (8 of 8) Schematic Diagram

TH-42PA60L DG-Board (8 of 8) Schematic Diagram

64

65

66

67

68

69

70

71

72

6 Parts Location & Mechanical Replacement Parts List

6.1. Parts Location

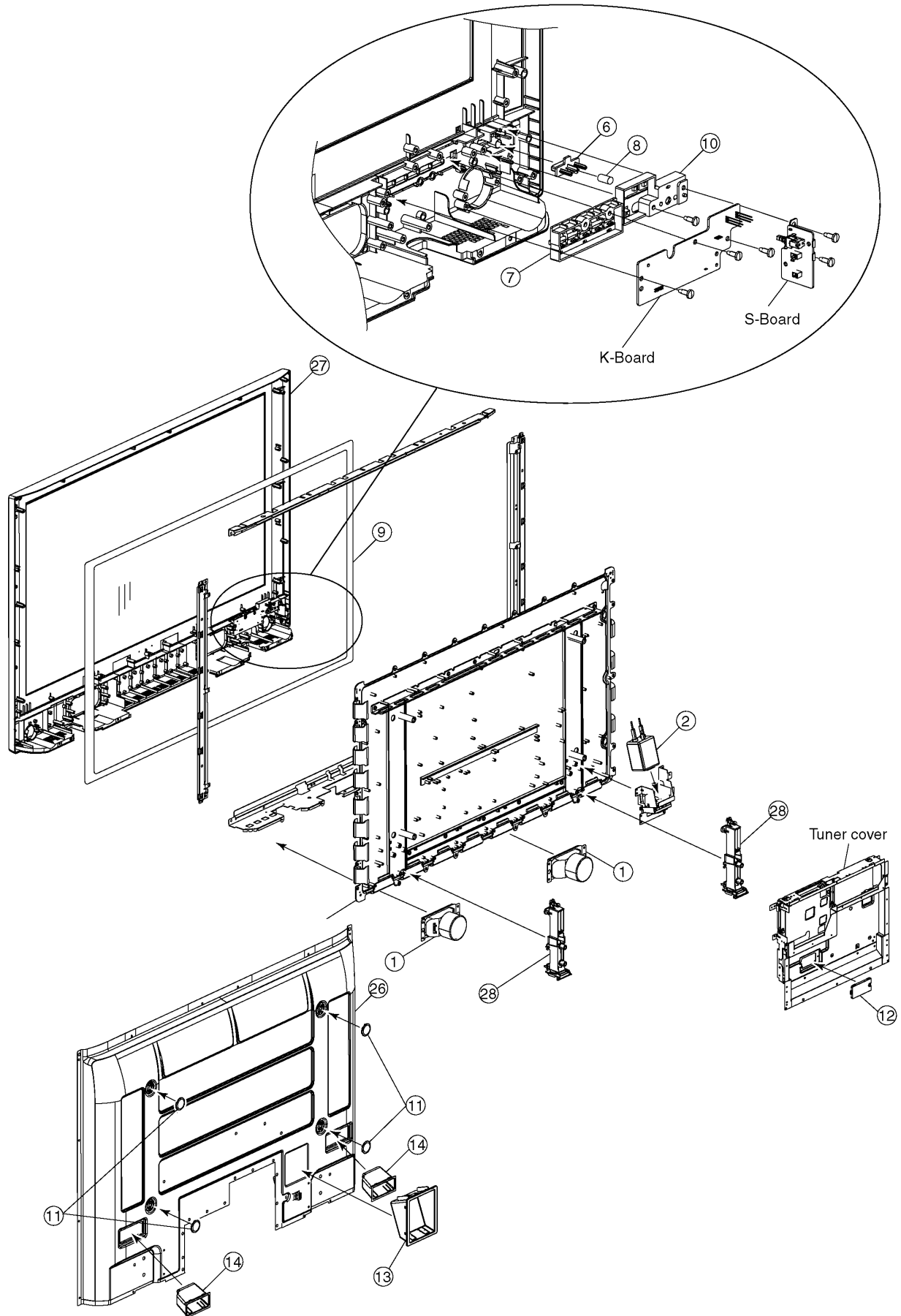

6.2. Packing Exploded Views (1)

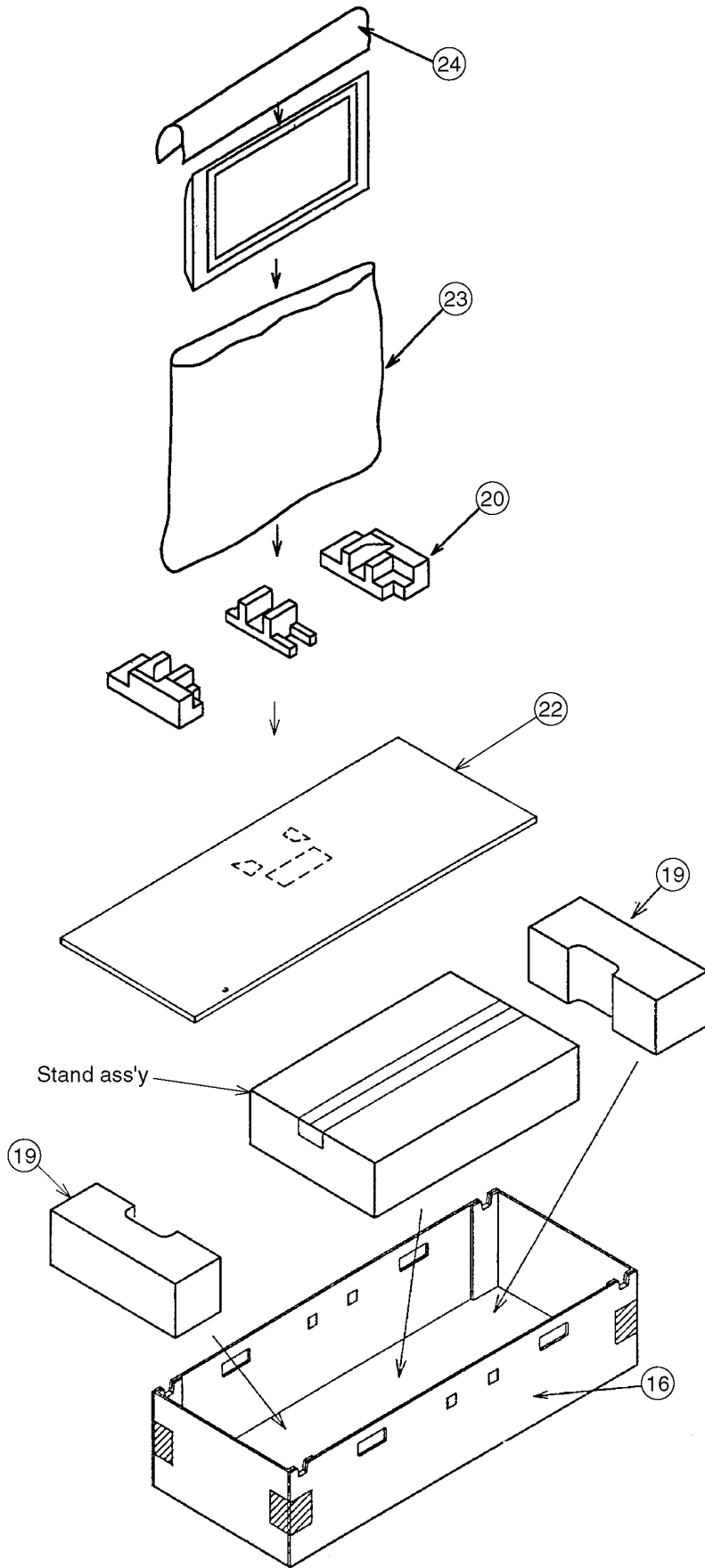

6.3. Packing Exploded Views (2)

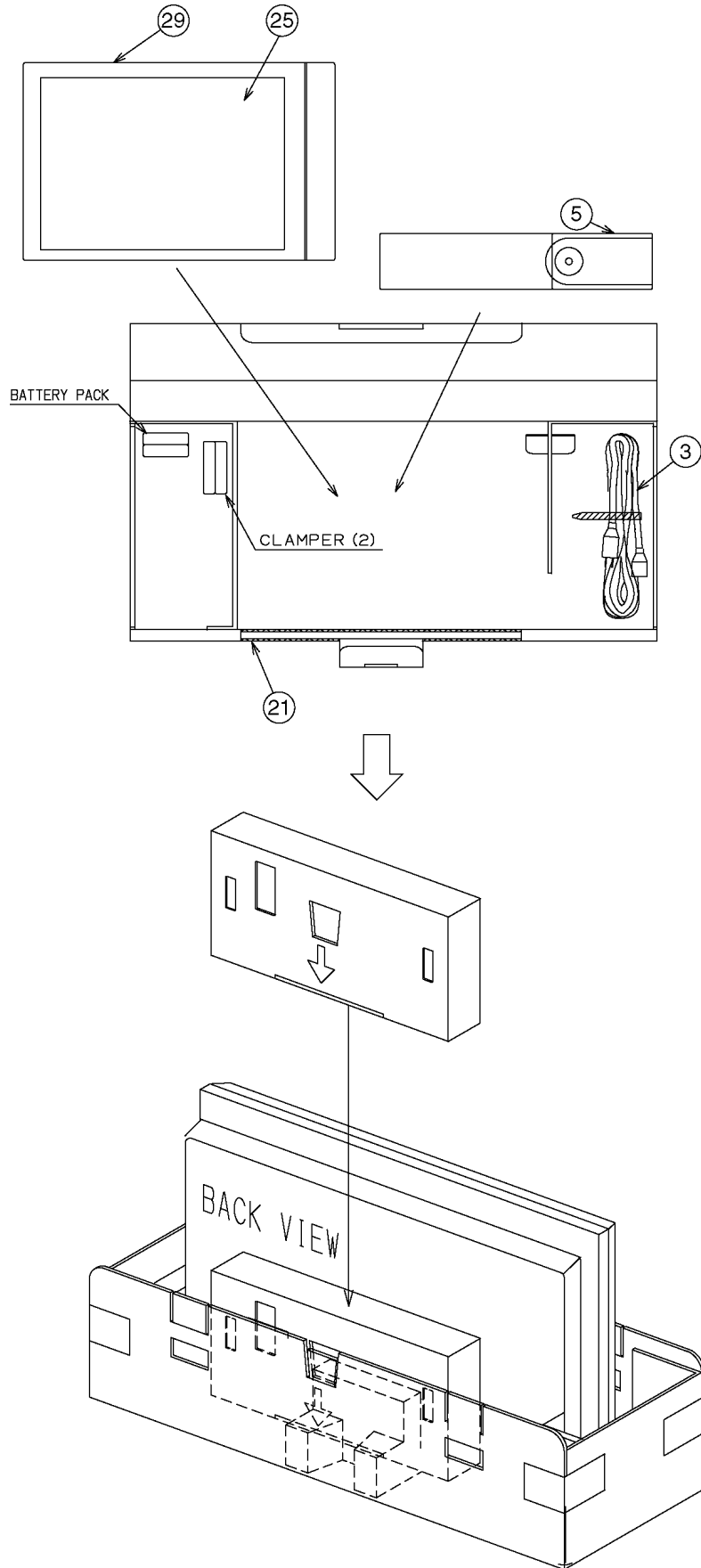

6.4. Packing Exploded Views (3)

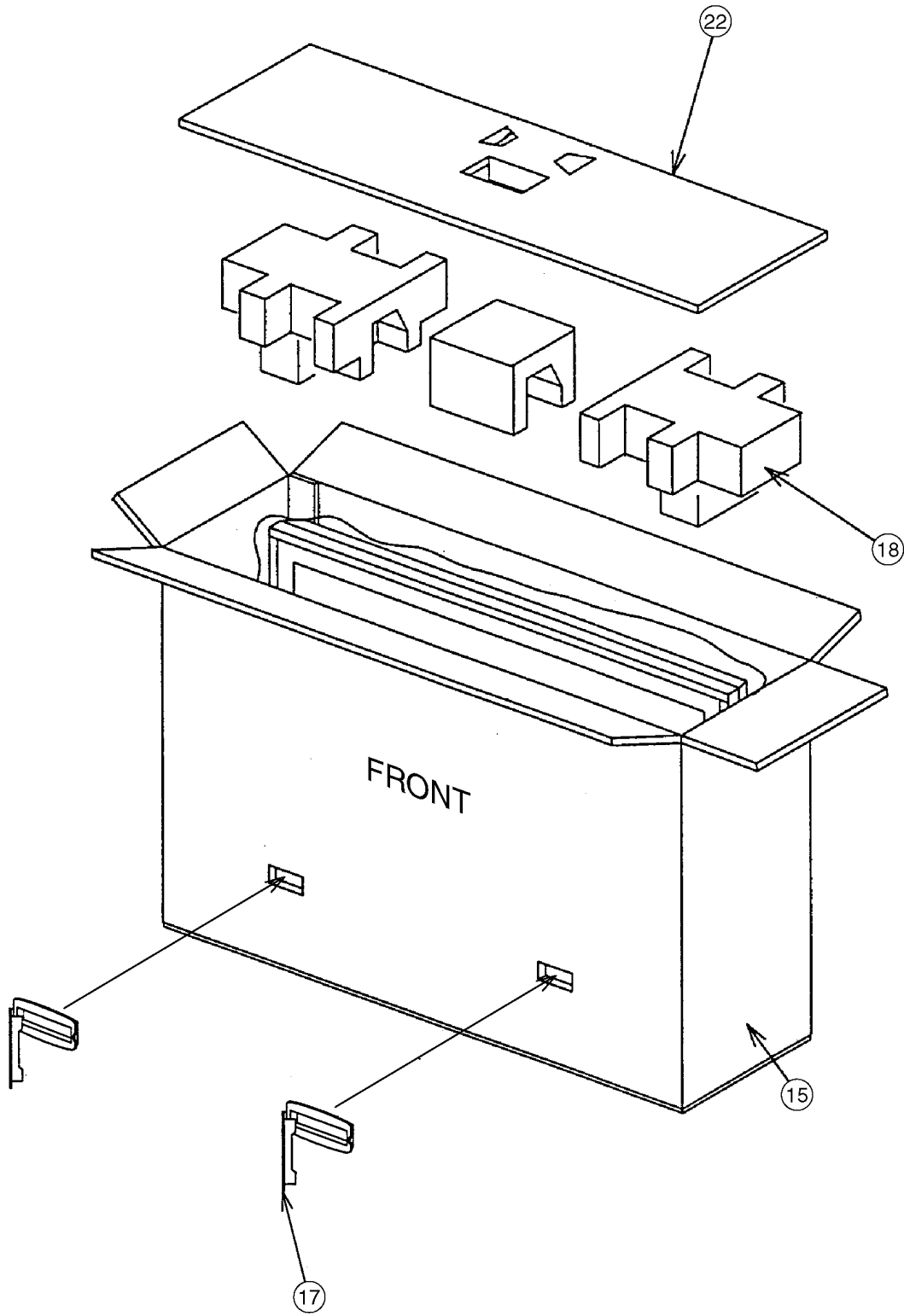

6.5. Stand Exploded Views

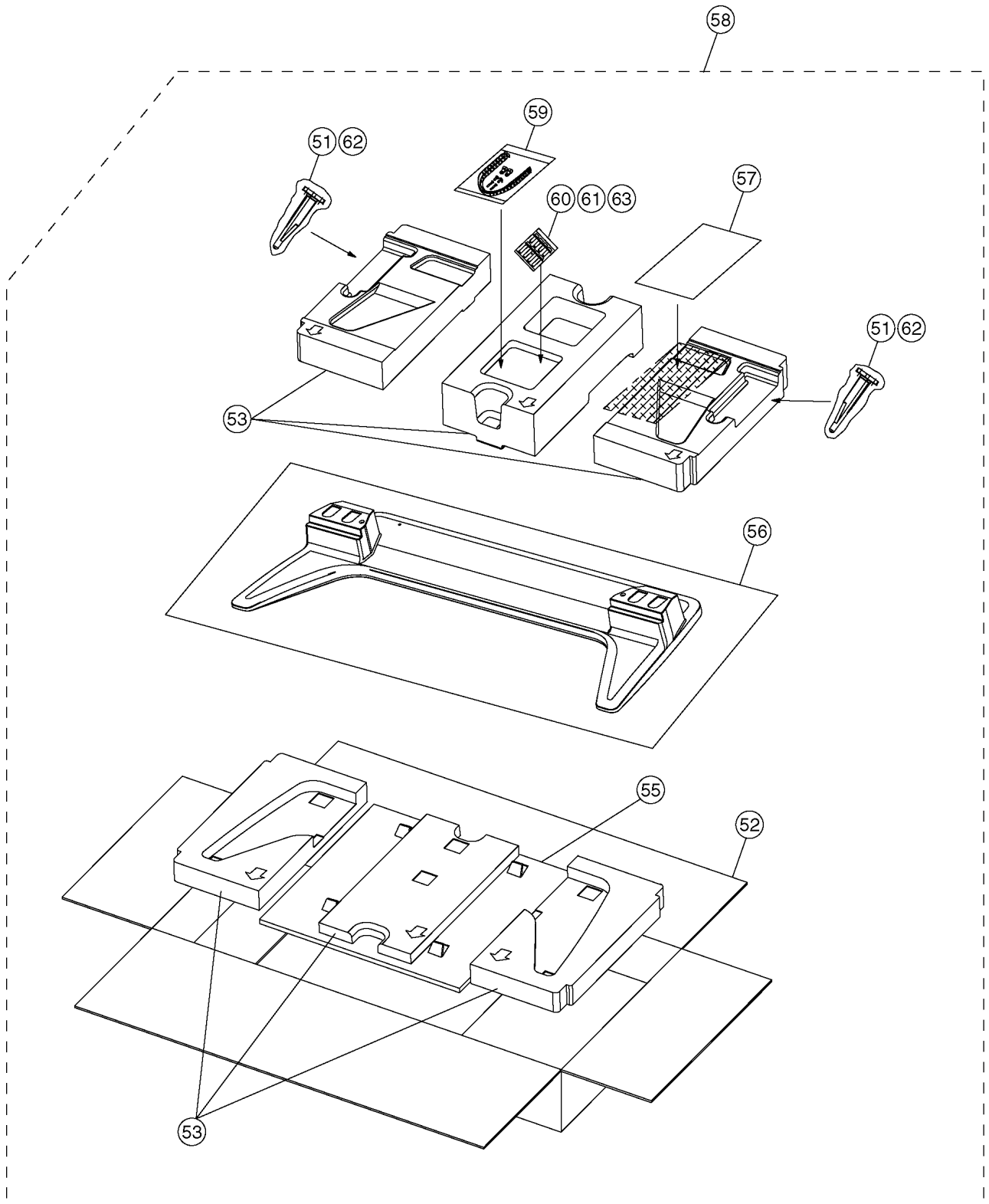

6.6. Mechanical Replacement Parts List (PDP TV)

Ref. No.	Part No.	Part Name & Description	Pcs	Remarks
1	EAS12S08B	SPEAKER	2	
	J0KG00000014	FILTER	1	
	J0KG00000042	NOISE FILTER	3	
	K1RGZBA00001	F TERMINAL (5C TYPE)	1	
2	K2AHYH000005	AC INLET	1	△
3	K2CG3DH00051	AC CORD	1	△
3	K2CS3YY00001	AC CORD (CHILI)	1	△
4	MD42S09A1J	PLASMA DISPLAY PANEL	1	△
5	N2QAYB000022	REMOTE CONTROL	1	
	TBMA149	PANASONIC BADGE (SILVER)	1	
6	TBXA46302	POWER BUTTON	1	
7	TBXA46402	5KEYS BUTTON	1	
8	TES4G204	SPRING	1	
	THEL0429	SCREW	28	
	THEL044N	SCREW	1	
	THEL047J	SCREW(HDMI:2)	1	
	THNA004N	NUT	1	
	THTF011N	SCREW	30	
	THW40973N	WASHER	1	
	THWC018N	WASHER	1	
9	TKGA5272	FRONT GLASS	1	
10	TKKC5208	PANEL LIGHT	1	
11	TKKL5231	M8 SPACER CAP	4	
12	TKKL5269	COVER	1	
13	TKPA94301	INLET COVER	1	
14	TKRA46201	REAR COVER HANDLE	2	
	TMKG556	CUSHION(TKG/UPPER/BOTTOM)	2	
	TMKG557	CUSHION(TKG/LEFT/RIGHT)	2	
	TMKG564	SPEAKER SPONGE	2	
	TMM16473-1	CLAMPER	1	
	TMM16474	CLAMPER	1	
	TMM17499	CLAMPER	1	
	TMM25401	CLAMPER	4	
	TMM25401	CLAMPER	4	
	TMM25401	CLAMPER	2	
	TMM6496-1	CLAMPER	1	
	TMM7464-2	CLAMPER	3	
	TMME047	CLAMPER	2	
	TMME061	CLAMPER	1	
	TMME190	CLAMPER	2	
	TMME226	CLAMPER	1	
	TMME258	CLAMPER	2	
	TMME260	CLAMPER	3	
	TMME260	CLAMPER	1	
	TMMX037	CLAMPER	1	
15	TPCB75303	CARTON BOX TOP	1	△
16	TPCB75401	CARTON BOTTOM	1	
17	TPD169487	JOINT	4	
18	TPDA1393	CUSHION TOP	1	
19	TPD2AA04901	CUSHION FOR STAND	1	
20	TPDA1411	CUSHION BOTTOM	1	
21	TPDF1260	PAPER BOX	1	
22	TPDF1379	TOP/BOTTOM PAD	2	
23	TPEH170	PROTECT COVER	1	
24	TPEH273	TOP-PROTECT SHEET	1	
25	TQBC2085-1	INSTRUCTION BOOK (ENGLISH)	1	△
25	TQBC2086-1	INSTRUCTION BOOK (SPANISH)	1	△
25	TQBC2087-1	INSTRUCTION BOOK (PORTUGUESE)	1	△
	TSXL513	CABLE (D31-C11 /D32-C21)	2	
	TSXL519	CABLE (C12-C22)	1	
	TSXL520	CABLE (DG1-H1)	1	
	TSXL521	CABLE (DG15-HC15)	1	

Ref. No.	Part No.	Part Name & Description	Pcs	Remarks
	TSXL522	CABLE(DG20-PA20)	1	
	TSXL523	CABLE(D3-DG3)	1	
26	TTUA1363	REAR COVER	1	△
27	TXFKE01BLTA	ESCUTCHEON ASSY	1	△
28	TXFMZ01YFSUB	STAND BLOCK ASSY	2	
	TXJ/SWYFSE	SPEAKER LEAD	1	
	XTB4+12GFJ	SCREW	4	
	XTB4+12GFJ	SCREW	31	
	XTB4+12GFJ	SCREW	12	
	XTB4+15AFJK	SCREW	16	
	XTV3+10JFJK	SCREW	4	
	XTW3+10TFJ	SCREW	4	
	XYC4+FJ35FJK	SCREW	4	
	XYN3+F8FJ	SCREW	2	
	XYN3+F8FJ	SCREW	16	
	XYN3+F8FJ	SCREW	2	
	XYN3+J12FJ	SCREW	13	
	XYN3+J12FJ	SCREW	12	
	XYN4+E8FJ	SCREW	1	
	XYN5+C15FJ	SCREW	8	
29	XZBT6506	POLY BAG	1	

6.7. Mechanical Replacement Parts List (Stand)

Ref. No.	Part No.	Part Name & Description	Pcs	Remarks
	TBL63413-1	RUBBER	8	
51	TBLA3341	STAND POLE	2	
52	TPCB79101	CARTON BOX (STAND)	1	
53	TPDA1120	CUSHION TOP (STAND)	1	
54	TPDA1121	CUSHION BOTTOM (STAND)	1	
55	TPDF1401	PAD BOTTOM (STAND)	1	
56	TPEH270	POLY BAG (STAND)	1	
57	TQZH624	INSTRUCTION SHEET	1	
58	TXFBL010ZES	STAND ASSY	1	
59	TXFMM010ZES	STOPPER	1	
	XTB4+8JFJ	SCREW	8	
60	XYN5+F20J	SCREW	4	
61	XYN5+F30FJK	BLACK SCREW	4	
62	XZB12X25D03	POLY BAG (STAND POLE)	2	
63	XZB7.5X9D05	POLY BAG (SCREW)	1	

7 Electrical Replacement Parts List

7.1. Replacement Parts List Notes

Important Safety Notice

Components identified by \triangle mark have special characteristics important for safety.
When replacing any of these components, use only manufacturer's specified parts.

RTL (Retention Time Limited)

Note: The marking (RTL) indicates that the Retention Time is Limited for this item.

After the discontinuation of this assembly in production, the item will continue to be available for a specific period of time. The retention period of availability is dependant on the type of assembly, and in accordance with the laws governing part and product retention. After the end of this period, the assembly will no longer be available.

Abbreviation of part name and description

1. Resistor

Example:

ERD25TJ104 \underline{C} 100KOHM, \underline{J} , 1/4W
 Type Allowance

2. Capacitor

Example:

ECKF1H103ZF \underline{C} 0.01UF, \underline{Z} , 50V
 Type Allowance

Type	Allowance
C : Carbon	F : $\pm 1\%$
F : Fuse	G : $\pm 2\%$
M : Metal Oxide Metal Film	J : $\pm 5\%$
S : Solid	K : $\pm 10\%$
W : Wire Wound	M : $\pm 20\%$

Type	Allowance
C : Ceramic	C : $\pm 0.25\text{pF}$
E : Electrolytic	D : $\pm 0.5\text{pF}$
P : Polyester	F : $\pm 1\text{pF}$
Polypropylene	G : $\pm 3\text{pF}$
Tantalum	J : $\pm 5\text{pF}$
Tantalum	K : $\pm 10\text{pF}$
Tantalum	L : $\pm 15\text{pF}$
Tantalum	M : $\pm 20\text{pF}$
Tantalum	P : +100%, -0%
Tantalum	Z : +80%, -20%

7.2. Electrical Replacement Parts List

Ref. No.	Part No.	Part Name & Description	Pcs	Remarks
F401.402	K5D802BNA005	TIME LAG FUSE HIGH	2	△
C001	EEUFCA222	E 2200UF, 10V	1	
C002,03	ECA1HM100	E 10UF, 50V	2	
C007	ECJ1XF1C104Z	C 0.1UF, Z, 16V	1	
C009	ECJ1VF1H104Z	C 0.1UF, Z, 50V	1	
C11	K1MN55BA0076	55P CONNECTOR	1	
C12	K1MN20BA0231	20P CONNECTOR	1	
C013	ECJ1XF1C104Z	C 0.1UF, Z, 16V	1	
C016	ECJ1XF1C104Z	C 0.1UF, Z, 16V	1	
C018,19	ECJ1VC1H330J	C 33PF, J, 50V	2	
C020	ECJ1XF1H102Z	C 1000PF, Z, 50V	1	
C021	ECJ1XC1H101J	C 100PF, J, 50V	1	
C21	K1MN55BA0076	55P CONNECTOR	1	
C22	K1MN20BA0231	20P CONNECTOR	1	
C23	K1KA12BA0107	12P CONNECTOR	1	
C1100	ECJ0EB1A104K	C 0.1UF, K, 10V	1	
C1102	ECJ0EB1A104K	C 0.1UF, K, 10V	1	
C1103	ECJ0EB1E271K	C 270PF, K, 25V	1	
C1105	ECJ0EB1E271K	C 270PF, K, 25V	1	
C1106	ECJ1VB1A105K	C 0.01UF, Z, 50V	1	
C1107	EEEB0G101R	C 100PF, J, 4V	1	
C1109-11	ECJ0EB1A104K	C 0.1UF, K, 10V	3	
C1112	ECJ0EB1E271K	C 270PF, K, 25V	1	
C1114	ECJ0EB1A104K	C 0.1UF, K, 10V	1	
C1116	ECJ0EB1A104K	C 0.1UF, K, 10V	1	
C1118-23	ECJ0EB1A104K	C 0.1UF, K, 10V	6	
C1125	ECJ0EB1A104K	C 0.1UF, K, 10V	1	
C1127-32	ECJ0EB1A104K	C 0.1UF, K, 10V	6	
C1133,34	ECJ1XC1H150J	C 15PF, J, 50V	2	
C1135-42	ECJ0EB1A104K	C 0.1UF, K, 10V	8	
C1144-50	ECJ0EB1A104K	C 0.1UF, K, 10V	7	
C1152	ECJ0EB1A104K	C 0.1UF, K, 10V	1	
C1153	EEEB0G101R	C 100PF, J, 4V	1	
C1154	ECJ0EB1A104K	C 0.1UF, K, 10V	1	
C1155	ECJ0EB1C103K	C 0.010UF, K, 16V	1	
C1156,57	ECJ1XC1H220J	C 22PF, J, 50V	2	
C1158	F1J0J1060004	C 0.010UF, K, 16V	1	
C1159	ECJ0EB1A104K	C 0.1UF, K, 10V	1	
C1161	ECJ1VB1A105K	C 0.01UF, Z, 50V	1	
C1167,68	ECJ1VB1A105K	C 0.01UF, Z, 50V	2	
C1172	ECJ0EB1A104K	C 0.1UF, K, 10V	1	
C1177	ECJ1VB1A334K	C 0.1UF, K, 16V	1	
C1178	ECJ1VB1A105K	C 0.01UF, Z, 50V	1	
C1190	ECJ0EB1C103K	C 0.010UF, K, 16V	1	
C1209	ECJ1VB1A105K	C 0.01UF, Z, 50V	1	
C1211	ECJ1XC1H471J	C 470PF, J, 50V	1	
C1215	ECJ1XC1H561J	C 560PF, J, 50V	1	
C1219	EEEB1C100R	C 10PF, J, 16V	1	
C1221	ECJ0EB1H102K	C 1000PF, K, 50V	1	
C1222,23	F1J0J1060004	C 0.010UF, K, 16V	2	
C1224	ECJ0EB1A104K	C 0.1UF, K, 10V	1	
C1226	F1J0J1060004	C 0.010UF, K, 16V	1	
C1227	ECJ0EB1H101K	C 100PF, K, 50V	1	
C1228-34	EEEB1C470P	C 47PF, J, 16V	7	
C2005,06	ECJ1XC1H561J	C 560PF, J, 50V	2	
C2010,11	ECJ1XC1H561J	C 560PF, J, 50V	2	

Ref. No.	Part No.	Part Name & Description	Pcs	Remarks
C2013,14	ECJ1XC1H561J	C 560PF, J, 50V	2	
C2016,17	ECJ1XC1H561J	C 560PF, J, 50V	2	
C2019	ECA1CM221	E 220UF, 16V	1	
C2020	ECA1HM220	E 22UF, 50V	1	
C2021,22	ECJ1XC1H561J	C 560PF, J, 50V	2	
C2111	ECJ2VF1C104Z	C 0.1UF, Z, 16V	1	
C2116	ECJ2VF1C104Z	C 0.1UF, Z, 16V	1	
C2118,19	ECEA1CN470U	E 47UF, 16V	2	
C2127	ECA1CMH101	E 100UF, 16V	1	
C2128	ECJ2VF1C104Z	C 0.1UF, Z, 16V	1	
C2129,30	F1J1A1050002	C 1UF, Z, 50V	2	
C2131	ECJ2VF1C104Z	C 0.1UF, Z, 16V	1	
C2132	EEEB1C100R	C 10PF, J, 16V	1	
C2133,34	ECJ1XC1H470J	C 47PF, J, 50V	2	
C2139-43	ECJ1VB1H103K	C 0.001UF, K, 50V	5	
C2146	ECJ2VF1C104Z	C 0.1UF, Z, 16V	1	
C2147	ECA1HM220	E 22UF, 50V	1	
C2148-50	ECJ2FB1C105K	C 1UF, K, 16V	3	
C2152	ECJ2FB1C105K	C 1UF, K, 16V	1	
C2153	ECJ2FF1C475Z	C 0.047UF, Z, 16V	1	
C2154	ECJ2VF1C104Z	C 0.1UF, Z, 16V	1	
C2159,60	ECJ2FB1C105K	C 1UF, K, 16V	2	
C2161	ECA1CMH101	E 100UF, 16V	1	
C2162-65	ECJ2FB1C105K	C 1UF, K, 16V	4	
C2168,69	ECJ2FB1C105K	C 1UF, K, 16V	2	
C2170-72	ECJ1VB1H102K	C 1000PF, K, 50V	3	
C2173	ECJ1VB1H103K	C 0.001UF, K, 50V	1	
C2174	ECJ1VB1H102K	C 1000PF, K, 50V	1	
C2175-77	ECJ1VB1H103K	C 0.001UF, K, 50V	3	
C2178,79	EEEB1C100R	C 10PF, J, 16V	2	
C2181	ECJ2VF1C104Z	C 0.1UF, Z, 16V	1	
C2183	EEEB1H3R3R	C 3.3PF, J, 50V	1	
C2184,85	ECJ2VF1C104Z	C 0.1UF, Z, 16V	2	
C2189,90	ECJ2FB1C105K	C 1UF, K, 16V	2	
C2191	ECJ2VF1C104Z	C 0.1UF, Z, 16V	1	
C2192	EEEB1C100R	C 10PF, J, 16V	1	
C2195	ECJ1XC1H470J	C 47PF, J, 50V	1	
C2196	ECJ2VF1C104Z	C 0.1UF, Z, 16V	1	
C2197	ECJ2FB0J225K	C 2.2UF, Z, 16V	1	
C2198	EEEB0J101P	C 100PF, J, 6.3V	1	
C2199	ECJ1VC1H560J	C 56PF, J, 50V	1	
C2200	ECJ1XC1H470J	C 47PF, J, 50V	1	
C2201	ECJ1XC1H030C	C 3PF, C, 50V	1	
C2202	ECJ1XC1H050C	C 5PF, C, 50V	1	
C2203	ECJ1VC1H100C	C 10PF, C, 50V	1	
C2204	ECJ1XC1H220J	C 22PF, J, 50V	1	
C2211	ECJ1VB1C104K	C 0.1UF, K, 16V	1	
C2213	ERJ3GEY0R00	M 0 OHM, 1/16W	1	
C2222	ECJ2VF1C104Z	C 0.1UF, Z, 16V	1	
C2223	ECJ1XC1H390J	C 39PF, J, 50V	1	
C2225	ECJ2FB1C105K	C 1UF, K, 16V	1	
C2226	ECJ1VB1H102K	C 1000PF, K, 50V	1	
C2237-40	ECJ1VB1H103K	C 0.001UF, K, 50V	4	
C2301	ECA1EHG471	E 470UF, 25V	1	
C2303	ECA1CMH101	E 100UF, 16V	1	
C2307	ECA1CMH101	E 100UF, 16V	1	
C2314	ECJ1VB1C105K	C 0.01UF, K, 16V	1	
C2317	ECJ2FB1A105K	C 1UF, K, 10V	1	
C2320	ECJ2FB1A105K	C 1UF, K, 10V	1	

Ref. No.	Part No.	Part Name & Description	Pcs	Remarks
C2321	ECJ2XB1H103K	C 0.01UF, K, 50V	1	
C2322	ECJ2FB1A105K	C 1UF, K, 10V	1	
C2323,2 4	ECJ2FB1E224K	C 22UF, K, 25V	2	
C2325,2 6	ECJ1VB1E104K	C 0.10UF, K, 25V	2	
C2327	FLJ1H474A757	C 0.47UF, 50V	1	
C2328- 31	ECJ2FB1E105K	C 1UF, K, 25V	4	
C2332,3 3	ECA1EHG471	E 470UF, 25V	2	
C2334,3 5	ECJ1VB1E104K	C 0.10UF, K, 25V	2	
C2336	FLJ1H474A757	C 0.47UF, 50V	1	
C2337,3 8	ECJ2FB1E224K	C 22UF, K, 25V	2	
C2341	ECJ3YB1E106M	C 10 UF, K, 25V	1	
C2342	ECJ2FB1E105K	C 1UF, K, 25V	1	
C2372	ECA1HHG100	E 10UF, 50V	1	
C2373	ECJ1VF1H104Z	C 0.1UF, Z, 50V	1	
C2374	ECJ1VF1A105Z	C 1UF, Z, 10V	1	
C2380	ECJ1VB1H103K	C 0.001UF, K, 50V	1	
C2382	ECJ1VB1C105K	C 0.01UF, K, 16V	1	
C2385	ECJ2FB1A105K	C 1UF, K, 10V	1	
C2387	ECJ2FB1A105K	C 1UF, K, 10V	1	
C2393,9 4	ECJ1VB1C105K	C 0.01UF, K, 16V	2	
C2401	ECJ2FB1A105K	C 1UF, K, 10V	1	
C2402	ECJ2FB0J106M	C 10UF, Z, 6.3V	1	
C2403	ECJ1VB1H103K	C 0.001UF, K, 50V	1	
C2417	ECJ2FB0J106M	C 10UF, Z, 6.3V	1	
C2430	ECJ1VF1A105Z	C 1UF, Z, 10V	1	
C2512	ECJ3XB0J106M	C 10UF, M, 6.3V	1	
C2515	ECJ1VB1H103K	C 0.001UF, K, 50V	1	
C3005	ECJ2VF1C104Z	C 0.1UF, Z, 16V	1	
C3021- 25	FLJ1A1050002	C 1UF, Z, 50V	5	
C3026	ECJ1VB1H103K	C 0.001UF, K, 50V	1	
C3033	FLJ1A1050002	C 1UF, Z, 50V	1	
C3035	FLJ1A1050002	C 1UF, Z, 50V	1	
C3036	ECJ1VB1H103K	C 0.001UF, K, 50V	1	
C3038	ECJ2VF1C104Z	C 0.1UF, Z, 16V	1	
C3039	ECJ1VB1H103K	C 0.001UF, K, 50V	1	
C3040	ECJ2VF1C104Z	C 0.1UF, Z, 16V	1	
C3041	ECJ1VB1H103K	C 0.001UF, K, 50V	1	
C3043	FLJ1A1050002	C 1UF, Z, 50V	1	
C3046	ECJ1VB1H103K	C 0.001UF, K, 50V	1	
C3047	FLJ1A1050002	C 1UF, Z, 50V	1	
C3048	ECJ1VB1H103K	C 0.001UF, K, 50V	1	
C3049,5 0	FLJ1A1050002	C 1UF, Z, 50V	2	
C3051- 53	ECJ1VB1H103K	C 0.001UF, K, 50V	3	
C3054- 56	FLJ1A1050002	C 1UF, Z, 50V	3	
C3058	ECA1EM471	E 470UF, 25V	1	
C3059,6 0	ECJ2VF1C105Z	C 1UF, Z, 16V	2	
C3062,6 3	ECJ2VF1C104Z	C 0.1UF, Z, 16V	2	
C3065	ECJ1VB1H103K	C 0.001UF, K, 50V	1	
C3067	ECJ1VB1H103K	C 0.001UF, K, 50V	1	
C3069	ECA1EM471	E 470UF, 25V	1	
C3070	ECJ2VF1C104Z	C 0.1UF, Z, 16V	1	
C3075	ECA1CM221	E 220UF, 16V	1	
C3207	ECJ2FB1C105K	C 1UF, K, 16V	1	
C3208	ECJ2FB1C474K	C 0.47UF, Z, 16V	1	
C3214	ECJ2FF1A106Z	C 0.001UF, Z, 10V	1	
C3216	ECJ2FF1A106Z	C 0.001UF, Z, 10V	1	
C3226- 28	ECJ2FF1A106Z	C 0.001UF, Z, 10V	3	
C3230	ECJ2VF1C104Z	C 0.1UF, Z, 16V	1	
C3233	ECJ2VF1C104Z	C 0.1UF, Z, 16V	1	
C3241	ECJ2VF1C104Z	C 0.1UF, Z, 16V	1	
C3251	ECJ1XF1C104Z	C 0.1UF, Z, 16V	1	
C3252	ECJ2FB1C105K	C 1UF, K, 16V	1	

Ref. No.	Part No.	Part Name & Description	Pcs	Remarks
C3253	ECJ1XF1C104Z	C 0.1UF, Z, 16V	1	
C3262	ECJ1VB1H472K	C 4700PF, K, 50V	1	
C3265	ECJ1VB1H102K	C 1000PF, K, 50V	1	
C3268	ECJ1VB1H103K	C 0.001UF, K, 50V	1	
C3270- 73	ECJ1XC1H680J	C 68PF, J, 50V	4	
C3274	ECJ1VB1H102K	C 1000PF, K, 50V	1	
C4003- 08	FLJ0J1060004	C 0.010UF, K, 16V	6	
C4014,1 5	FLJ0J1060004	C 0.010UF, K, 16V	2	
C4023	FLJ0J1060004	C 0.010UF, K, 16V	1	
C4026	ECJ0EB1A104K	C 0.1UF, K, 10V	1	
C4027	ECJ1VB1A105K	C 0.01UF, Z, 50V	1	
C4028	ECJ0EB1C103K	C0.010UF, K, 16V	1	
C4112	FLJ0J1060004	C 0.010UF, K, 16V	1	
C4117	ECJ0EB1A104K	C 0.1UF, K, 10V	1	
C4158	ECJ1VB1A105K	C 0.01UF, Z, 50V	1	
C4159	FLH1C104A065	C 0.1UF, K, 16V	1	
C4160	ECJ0EB1A104K	C 0.1UF, K, 10V	1	
C4165	ECJ0EB1A104K	C 0.1UF, K, 10V	1	
C4168	ECJ1XC1H680J	C 68PF, J, 50V	1	
C4171	ECJ1XC1H471J	C 470PF, J, 50V	1	
C4172,7 3	FLH1C104A065	C 0.1UF, K, 16V	2	
C4174	ECJ0EB1A104K	C 0.1UF, K, 10V	1	
C4175	FLH1C104A065	C 0.1UF, K, 16V	1	
C4176	ECJ1VB0J225K	C 2.2UF, K, 6.3V	1	
C4177	ECJ2FB1C684K	C 68UF, Z, 16V	1	
C4178	ECJ1XB1C393K	C 0.039UF, K, 16V	1	
C4180	FLH1C104A065	C 0.1UF, K, 16V	1	
C4185,8 6	ECJ3XB0J106M	C 10UF, M, 6.3V	2	
C4188	FLJ0J1060004	C 0.010UF, K, 16V	1	
C4189- 91	ECJ0EB1A104K	C 0.1UF, K, 10V	3	
C4196	FLH1C104A065	C 0.1UF, K, 16V	1	
C4199	ECJ0EB1C103K	C0.010UF, K, 16V	1	
C4200	F2G0J470A019	E 47UF 6.3V	1	
C4201	ECJ0EB1C103K	C0.010UF, K, 16V	1	
C4204	ECJ0EB1A104K	C 0.1UF, K, 10V	1	
C4205,0 6	FLH1C104A065	C 0.1UF, K, 16V	2	
C4208,0 9	ECJ0EB1A104K	C 0.1UF, K, 10V	2	
C4211	ECJ0EB1A104K	C 0.1UF, K, 10V	1	
C4215	ECJ0EB1A104K	C 0.1UF, K, 10V	1	
C4216	F2G0J470A019	E 47UF 6.3V	1	
C4217	FLH1C104A065	C 0.1UF, K, 16V	1	
C4218	ECJ0EB1H102K	C 1000PF, K, 50V	1	
C4219	ECJ1VB1A105K	C 0.01UF, Z, 50V	1	
C4224	ECJ0EB1A104K	C 0.1UF, K, 10V	1	
C4227	ECJ1VB1C823K	C 0.082UF, K, 16V	1	
C4228	ECJ0EB1C103K	C0.010UF, K, 16V	1	
C4235	ECJ0EB1C103K	C0.010UF, K, 16V	1	
C4244	ECJ1VB1A105K	C 0.01UF, Z, 50V	1	
C4245	ECJ0EB1A104K	C 0.1UF, K, 10V	1	
C4248	ECJ0EB1A104K	C 0.1UF, K, 10V	1	
C4253	F2G0J470A019	E 47UF 6.3V	1	
C4256	ECJ1VB1A105K	C 0.01UF, Z, 50V	1	
C4262- 64	ECJ0EB1A104K	C 0.1UF, K, 10V	3	
C4266	ECJ0EB1C103K	C0.010UF, K, 16V	1	
C4269	ECJ1VB1A105K	C 0.01UF, Z, 50V	1	
C4272	F2G0J470A019	E 47UF 6.3V	1	
C4273	ECJ0EB1A104K	C 0.1UF, K, 10V	1	
C4282	ECJ0EB1A104K	C 0.1UF, K, 10V	1	
C4284	ECJ0EB1A104K	C 0.1UF, K, 10V	1	
C4288	ECJ0EB1A104K	C 0.1UF, K, 10V	1	
C4290	EEHBOJ330R	C 33PF, J, 6.3V	1	
C4292	ECJ0EB1A104K	C 0.1UF, K, 10V	1	
C4296	FLJ0J1060004	C 0.010UF, K, 16V	1	
C4297	ECJ0EB1A104K	C 0.1UF, K, 10V	1	
C4298- 06	ECJ1VB1A105K	C 0.01UF, Z, 50V	9	

Ref. No.	Part No.	Part Name & Description	Pcs	Remarks
C4307-09	ECJ0EB1A104K	C 0.1UF, K, 10V	3	
C4310	ECJ0EB1C103K	C0.010UF, K, 16V	1	
C4311	ECJ0EB1A104K	C 0.1UF, K, 10V	1	
C4312	ECJ0EB1C103K	C0.010UF, K, 16V	1	
C4313,14	ECJ0EB1A104K	C 0.1UF, K, 10V	2	
C4315	FLJ0J1060004	C 0.010UF, K, 16V	1	
C4316-18	ECJ0EB1A104K	C 0.1UF, K, 10V	3	
C4320-22	ECJ0EB1A104K	C 0.1UF, K, 10V	3	
C4325	ECJ0EB1A104K	C 0.1UF, K, 10V	1	
C4327	ECJ0EB1A104K	C 0.1UF, K, 10V	1	
C4329,30	ECJ0EB1A104K	C 0.1UF, K, 10V	2	
C4331	FLJ0J1060004	C 0.010UF, K, 16V	1	
C4332	ECJ1VB1A105K	C 0.01UF, Z, 50V	1	
C4333-38	ECJ0EB1A104K	C 0.1UF, K, 10V	6	
C4339	ECJ1VB0J225K	C 2.2UF, K, 6.3V	1	
C4340	ECJ1XC1H471J	C 470PF, J, 50V	1	
C4341	EEEB1C470P	C 47PF, J, 16V	1	
C4342	ECJ0EB1A104K	C 0.1UF, K, 10V	1	
C4343	EEEB1C100R	C 10PF, J, 16V	1	
C4344,45	FLJ0J1060004	C 0.010UF, K, 16V	2	
C4346	ECJ0EB1A104K	C 0.1UF, K, 10V	1	
C4347	ECJ1VB1A105K	C 0.01UF, Z, 50V	1	
C4348	EEEB1C470P	C 47PF, J, 16V	1	
C4349	ECJ0EB1C103K	C0.010UF, K, 16V	1	
C4350,51	ECJ1XC1H181J	C 180PF, J, 50V	2	
C4352,53	ECJ1XC1H330J	C 33PF, J, 50V	2	
C4354	ECJ0EB1C103K	C0.010UF, K, 16V	1	
C4360	ECJ1VB1A105K	C 0.01UF, Z, 50V	1	
C4362	FLJ0J1060004	C 0.010UF, K, 16V	1	
C4363,64	ECJ0EB1A104K	C 0.1UF, K, 10V	2	
C4365	ECJ1VB1A105K	C 0.01UF, Z, 50V	1	
C4366	F2G0J470A019	E 47UF 6.3V	1	
C4367	ECJ0EB1A104K	C 0.1UF, K, 10V	1	
C4371	ECJ0EB1H102K	C 1000PF, K, 50V	1	
C4372	ECJ0EB1A104K	C 0.1UF, K, 10V	1	
C4373	ECJ1VB1A105K	C 0.01UF, Z, 50V	1	
C4374	ECJ0EB1A104K	C 0.1UF, K, 10V	1	
C4375,76	ECJ0EB1H102K	C 1000PF, K, 50V	2	
C4377	ECJ0EB1A104K	C 0.1UF, K, 10V	1	
C4379	ECJ0EB1A104K	C 0.1UF, K, 10V	1	
C4380	ECJ0EB1H102K	C 1000PF, K, 50V	1	
C4381,82	ECJ0EB1A104K	C 0.1UF, K, 10V	2	
C4383	ECJ0EB1H102K	C 1000PF, K, 50V	1	
C4384	ECJ0EB1A104K	C 0.1UF, K, 10V	1	
C4385	ECJ0EB1H102K	C 1000PF, K, 50V	1	
C4386	ECJ0EB1A104K	C 0.1UF, K, 10V	1	
C4387	ECJ0EB1H102K	C 1000PF, K, 50V	1	
C4388	ECJ1VB1A105K	C 0.01UF, Z, 50V	1	
C4389	ECJ0EB1A104K	C 0.1UF, K, 10V	1	
C4390	ECJ0EB1H102K	C 1000PF, K, 50V	1	
C4391	ECJ1VB1A105K	C 0.01UF, Z, 50V	1	
C4392	ECJ0EB1A104K	C 0.1UF, K, 10V	1	
C4393,94	ECJ0EB1H102K	C 1000PF, K, 50V	2	
C4395	ECJ0EB1A104K	C 0.1UF, K, 10V	1	
C4396	ECJ0EB1H102K	C 1000PF, K, 50V	1	
C4397,98	ECJ0EB1A104K	C 0.1UF, K, 10V	2	
C4399,00	ECJ1VB1A105K	C 0.01UF, Z, 50V	2	
C4401	ECJ0EB1A104K	C 0.1UF, K, 10V	1	
C4402,03	ECJ0EB1H102K	C 1000PF, K, 50V	2	
C4404	ECJ0EB1A104K	C 0.1UF, K, 10V	1	

Ref. No.	Part No.	Part Name & Description	Pcs	Remarks
C4405	ECJ1VB1A105K	C 0.01UF, Z, 50V	1	
C4406	ECJ0EB1H102K	C 1000PF, K, 50V	1	
C4407,08	ECJ0EB1A104K	C 0.1UF, K, 10V	2	
C4409	ECJ0EB1H102K	C 1000PF, K, 50V	1	
C4410	ECJ1VB1A105K	C 0.01UF, Z, 50V	1	
C4411,12	ECJ0EB1A104K	C 0.1UF, K, 10V	2	
C4413,14	ECJ0EB1H102K	C 1000PF, K, 50V	2	
C4415	ECJ0EB1A104K	C 0.1UF, K, 10V	1	
C4417	F2G0J470A019	E 47UF 6.3V	1	
C4418,19	ECJ1VB1A105K	C 0.01UF, Z, 50V	2	
C4420,21	ECJ0EB1A104K	C 0.1UF, K, 10V	2	
C4422-24	ECJ0EB1H102K	C 1000PF, K, 50V	3	
C4425,26	ECJ0EB1A104K	C 0.1UF, K, 10V	2	
C4427	ECJ0EB1H102K	C 1000PF, K, 50V	1	
C4428	ECJ0EB1A104K	C 0.1UF, K, 10V	1	
C4429,30	ECJ0EB1H102K	C 1000PF, K, 50V	2	
C4434	ECJ0EB1H102K	C 1000PF, K, 50V	1	
C4435	ECJ1VB1A105K	C 0.01UF, Z, 50V	1	
C4436-39	ECJ0EB1H102K	C 1000PF, K, 50V	4	
C4440	ECJ0EB1A104K	C 0.1UF, K, 10V	1	
C4441,42	ECJ0EB1H102K	C 1000PF, K, 50V	2	
C4447	ECJ1VB1A105K	C 0.01UF, Z, 50V	1	
C4448	ECJ0EB1C103K	C0.010UF, K, 16V	1	
C4451	ECJ0EB1H102K	C 1000PF, K, 50V	1	
C4452	ECJ0EB1A104K	C 0.1UF, K, 10V	1	
C4453,54	ECJ0EB1H102K	C 1000PF, K, 50V	2	
C4455	ECJ1VB1A105K	C 0.01UF, Z, 50V	1	
C4456	ECJ0EB1A104K	C 0.1UF, K, 10V	1	
C4457,58	ECJ0EB1H102K	C 1000PF, K, 50V	2	
C4459	ECJ0EB1A104K	C 0.1UF, K, 10V	1	
C4460	ECJ0EB1H102K	C 1000PF, K, 50V	1	
C4461	ECJ1XC1H820J	C 82PF, J, 50V	1	
C4462	ECJ0EB1A104K	C 0.1UF, K, 10V	1	
C4464	ECJ1VB1A105K	C 0.01UF, Z, 50V	1	
C4465	ECJ0EB1A104K	C 0.1UF, K, 10V	1	
C4466	ECJ0EB1C103K	C0.010UF, K, 16V	1	
C4467	ECJ0EB1A104K	C 0.1UF, K, 10V	1	
C4470	ECJ1VB1A105K	C 0.01UF, Z, 50V	1	
C4474	ECJ1VB1A105K	C 0.01UF, Z, 50V	1	
C4475,76	ECJ0EB1H102K	C 1000PF, K, 50V	2	
C4477	ECJ0EB1A104K	C 0.1UF, K, 10V	1	
C4478	ECJ1VB1A105K	C 0.01UF, Z, 50V	1	
C4479-81	ECJ0EB1H102K	C 1000PF, K, 50V	3	
C4482	ECJ1XC1H180J	C 18PF, J, 50V	1	
C4483	ECJ1XC1H150J	C 15PF, J, 50V	1	
C4493	ECJ0EB1A104K	C 0.1UF, K, 10V	1	
C4494	ECJ1VB1A105K	C 0.01UF, Z, 50V	1	
C4496	ECJ0EB1A104K	C 0.1UF, K, 10V	1	
C4497	EEEB0G101R	C 100PF, J, 4V	1	
C4498	ECJ1XC1H471J	C 470PF, J, 50V	1	
C4499	EEFCD0G560ER	56UF,	1	
C4501	ECJ0EB1A104K	C 0.1UF, K, 10V	1	
C4502	ECJ0EB1C103K	C0.010UF, K, 16V	1	
C4503	ECJ0EB1A104K	C 0.1UF, K, 10V	1	
C4504	ECJ0EB1C103K	C0.010UF, K, 16V	1	
C4505	ECJ0EB1A104K	C 0.1UF, K, 10V	1	
C4506	ECJ0EB1C103K	C0.010UF, K, 16V	1	
C4507	ECJ0EB1A104K	C 0.1UF, K, 10V	1	
C4508	ECJ0EB1C103K	C0.010UF, K, 16V	1	
C4509-11	ECJ0EB1A104K	C 0.1UF, K, 10V	3	
C4512	ECJ0EB1C103K	C0.010UF, K, 16V	1	

Ref. No.	Part No.	Part Name & Description	Pcs	Remarks
C4513	ECJ0EB1A104K	C 0.1UF, K, 10V	1	
C4514	ECJ0EB1C103K	C0.010UF, K, 16V	1	
C4515,16	ECJ0EB1A104K	C 0.1UF, K, 10V	2	
C4517	ECJ0EB1C103K	C0.010UF, K, 16V	1	
C4518	ECJ0EB1A104K	C 0.1UF, K, 10V	1	
C4519	ECJ0EB1C103K	C0.010UF, K, 16V	1	
C4520	ECJ0EB1A104K	C 0.1UF, K, 10V	1	
C4521	ECJ0EB1C103K	C0.010UF, K, 16V	1	
C4522	ECJ0EB1A104K	C 0.1UF, K, 10V	1	
C4523	ECJ0EB1C103K	C0.010UF, K, 16V	1	
C4524	ECJ0EB1A104K	C 0.1UF, K, 10V	1	
C4525	ECJ0EB1C103K	C0.010UF, K, 16V	1	
C4526	ECJ0EB1A104K	C 0.1UF, K, 10V	1	
C4527	ECJ0EB1C103K	C0.010UF, K, 16V	1	
C4528	F2G0J470A019	E 47UF 6.3V	1	
C4529	ECJ0EB1A104K	C 0.1UF, K, 10V	1	
C4530,31	ECJ0EB1H102K	C 1000PF, K, 50V	2	
C4532,33	ECJ0EB1A104K	C 0.1UF, K, 10V	2	
C4534	ECJ0EB1H102K	C 1000PF, K, 50V	1	
C4535	ECJ0EB1A104K	C 0.1UF, K, 10V	1	
C4536	ECJ1VB1A105K	C 0.01UF, Z, 50V	1	
C4537	EEHBOG101R	C 100PF, J, 4V	1	
C4538	ECJ0EB1A104K	C 0.1UF, K, 10V	1	
C4539	ECJ1VB1A105K	C 0.01UF, Z, 50V	1	
C4540	ECJ0EB1H102K	C 1000PF, K, 50V	1	
C4541	ECJ0EB1A104K	C 0.1UF, K, 10V	1	
C4543	F1H1C104A065	C 0.1UF, K, 16V	1	
C4544	ECJ1VB1C105K	C 0.01UF, K, 16V	1	
C5604	ECA1HHG100	E 10UF, 50V	1	
C5605	EEUFC1E471	E 470UF, 25V	1	
C5606	ECA1CM471	E 470UF, 16V	1	
C5609	ECA1HM220	E 22UF, 50V	1	
C5611	F2A1H331A257	E 330UF, 50V	1	
C5612	ECA1CM471	E 470UF, 16V	1	
C5613	ECJ1VB1E104K	C 0.10UF, K, 25V	1	
C5616	ECJ1VB1E104K	C 0.10UF, K, 25V	1	
C5617	ECA1CM471	E 470UF, 16V	1	
C5618,19	ECJ1VB1E104K	C 0.10UF, K, 25V	2	
C5622	ECA1CM471	E 470UF, 16V	1	
C5623	ECJ1VB1E104K	C 0.10UF, K, 25V	1	
C5626	ECJ1XF1C104Z	C 0.1UF, Z, 16V	1	
C5633	ECA1EM221	E 220UF, 25V	1	
C5637	ECJ1XF1C104Z	C 0.1UF, Z, 16V	1	
C5641-44	ECJ1XF1C104Z	C 0.1UF, Z, 16V	4	
C5645	ECA1CHG470	E 47UF, 16V	1	
C5646	ECJ1VB1H103K	C 0.001UF, K, 50V	1	
C5647	ECA1CHG470	E 47UF, 16V	1	
C5648	ECJ1VB1H103K	C 0.001UF, K, 50V	1	
C5670	ECJ1VB1E104K	C 0.10UF, K, 25V	1	
C5672	ECA1HHG100	E 10UF, 50V	1	
C5673	ECJ1XF1C104Z	C 0.1UF, Z, 16V	1	
C5685	ECA1HHG100	E 10UF, 50V	1	
C5686	ECJ2XB1H103K	C 0.01UF, K, 50V	1	
C6001	F1L2J562A022	C 5600UF, K,6.3V	1	
C6011-13	F2A2D221A022	E 220UF, 200V	3	
C6021	F1L2J562A022	C 5600UF, K,6.3V	1	
C6031	F0C2E405A176	E 0.040UF, 250V	1	
C6041-44	TCUY1C105ZFN	C 1UF, 16V	4	
C6111,12	F2A2D151A070	E 150UF, 200V	2	
C6132	F1L1E4750004	C 4.7UF, 25V	1	
C6134,35	F1L1E4750004	C 4.7UF, 25V	2	
C6152-54	F1L1E4750004	C 4.7UF, 25V	3	
C6156	ECQE2224KF	P 2.2UF, K,250V	1	
C6192	ECJ3YB1E105K	C 1UF, K, 25V	1	

Ref. No.	Part No.	Part Name & Description	Pcs	Remarks
C6194,95	F1L1E4750004	C 4.7UF, 25V	2	
C6201-08	ECQE2105B667	P 1UF, 250V	8	
C6211,12	F1L1E4750004	C 4.7UF, 25V	2	
C6213,14	F2A1E331A089	E 330UF, 25V	2	
C6221	ECJ2XB1H104K	C 0.1UF, K, 50V	1	
C6241	F2A1E331A089	E 330UF, 25V	1	
C6242	TCUY1C105ZFN	C 1UF, 16V	1	
C6243	ECJ2XB1H103K	C 0.01UF, K, 50V	1	
C6251	TCUY1C105ZFN	C 1UF, 16V	1	
C6261,62	ECA2CM101	E 100UF, 160V	2	
C6272,73	EEUFC1E221	E 220UF, 25V	2	
C6400	F1E2J102A002	C 1000PF, 600V	1	
C6401,02	F1L2J562A022	C 5600UF, K,6.3V	2	
C6410	F1E2J102A002	C 1000PF, 600V	1	
C6411-13	F2A2D221A022	E 220UF, 200V	3	
C6420	F1E2J102A002	C 1000PF, 600V	1	
C6421,22	F1L2J562A022	C 5600UF, K,6.3V	2	
C6431	F0C2E405A176	E 0.040UF, 250V	1	
C6472	ECJ2XB1H104K	C 0.1UF, K, 50V	1	
C6480	ECJ2XB1H104K	C 0.1UF, K, 50V	1	
C6502	F1L1E4750004	C 4.7UF, 25V	1	
C6504,05	F1L1E4750004	C 4.7UF, 25V	2	
C6511-18	ECQE2105B667	P 1UF, 250V	8	
C6522	F1L1E4750004	C 4.7UF, 25V	1	
C6524,25	F1L1E4750004	C 4.7UF, 25V	2	
C6526	ECQE2224KF	P 2.2UF, K,250V	1	
C6561	F2A1A1010074	E 100UF, 10V	1	
C6562	TCUY1C105ZFN	C 1UF, 16V	1	
C6563	F2A1A1010074	E 100UF, 10V	1	
C6564	TCUY1C105ZFN	C 1UF, 16V	1	
C6565,66	ECJ2XB1H103K	C 0.01UF, K, 50V	2	
C6581	ECJ3YB1E105K	C 1UF, K, 25V	1	
C6582	TCUY1C105ZFN	C 1UF, 16V	1	
C6592	ECA1EM471	E 470UF, 25V	1	
C6593	ECJ2XC1H102J	C 1000PF, J, 50V	1	
C6601,02	F1L1E4750004	C 4.7UF, 25V	2	
C6603	F1K2J102A014	C 1000UF, K,6.3V	1	
C6604	F2A2V470A020	E 47UF, 350V	1	
C6605	ECJ2XB1H104K	C 0.1UF, K, 50V	1	
C6606	F1K2J102A014	C 1000UF, K,6.3V	1	
C6610	ECJ3YB1E105K	C 1UF, K, 25V	1	
C6611	ECJ2XB1H103K	C 0.01UF, K, 50V	1	
C6612	ECJ3YB1E105K	C 1UF, K, 25V	1	
C6620	ECJ3XB2J222K	C 2200PF, K,630V	1	
C6641	ECQE2224KF	P 2.2UF, K,250V	1	
C6661,62	F1K2J102A014	C 1000UF, K,6.3V	2	
C6671	F1L1E4750004	C 4.7UF, 25V	1	
C6681,82	F1L1E4750004	C 4.7UF, 25V	2	
C6683	ECJ2XB1H104K	C 0.1UF, K, 50V	1	
C6691	ECA2CM101	E 100UF, 160V	1	
C6701-08	ECJ2XB1H104K	C 0.1UF, K, 50V	8	
C6721	ECA1HM101	E 100UF, 50V	1	
C6723-25	F1L1E4750004	C 4.7UF, 25V	3	
C6726,27	TCUY1C105ZFN	C 1UF, 16V	2	
C6728	ECJ2XC1H102J	C 1000PF, J, 50V	1	
C6752	TCUY1C105ZFN	C 1UF, 16V	1	
C6753	F1L1E4750004	C 4.7UF, 25V	1	
C6754	ECA1VM470	E 47UF, 35V	1	

Ref. No.	Part No.	Part Name & Description	Pcs	Remarks
C6755	ECJ2XB1H104K	C 0.1UF, K, 50V	1	
C6771	TCUY1C105ZFN	C 1UF, 16V	1	
C6772,7 3	F1L1E4750004	C 4.7UF, 25V	2	
C6775	F1L1E4750004	C 4.7UF, 25V	1	
C6776,7 7	ECJ2XB1H104K	C 0.1UF, K, 50V	2	
C6791	EEUFC1E221	E 220UF, 25V	1	
C6795	ECA1EM471	E 470UF, 25V	1	
C6802	EEUFC1E221	E 220UF, 25V	1	
C6803	ECJ2XB1H104K	C 0.1UF, K, 50V	1	
C6804	F2A2E100A022	E 10UF, 250V	1	
C6805	TCUY1C105ZFN	C 1UF, 16V	1	
C6806,0 7	ECA2CM101	E 100UF, 160V	2	
C6811	ECJ2XB1H103K	C 0.01UF, K, 50V	1	
C6823	ECJ2XB1H103K	C 0.01UF, K, 50V	1	
C6841	ECA2CM101	E 100UF, 160V	1	
C6845	ECJ2XB1H103K	C 0.01UF, K, 50V	1	
C6861	TCUY1C105ZFN	C 1UF, 16V	1	
C6862	ECJ3YB1E105K	C 1UF, K, 25V	1	
C6863	ECJ2XB1H103K	C 0.01UF, K, 50V	1	
C6871	TCUY1C105ZFN	C 1UF, 16V	1	
C6872	ECJ3YB1E105K	C 1UF, K, 25V	1	
C6873	ECJ2XB1H103K	C 0.01UF, K, 50V	1	
C6901	ECJ2XB1H102K	C 1000PF, K, 50V	1	
C6902	TCUY1C105ZFN	C 1UF, 16V	1	
C6904	TCUY1C105ZFN	C 1UF, 16V	1	
C6906	TCUY1C105ZFN	C 1UF, 16V	1	
C6908	TCUY1C105ZFN	C 1UF, 16V	1	
C6915,1 6	ECJ2XB1H221K	C 220PF, K, 50V	2	
C6921	ECJ2XB1H221K	C 220PF, K, 50V	1	
C6931	ECJ2XB1H102K	C 1000PF, K, 50V	1	
C6933,3 4	F1L2E105A013	E 0.10UF, 25V	2	
C6951	ECJ2XB1H102K	C 1000PF, K, 50V	1	
C6952	TCUY1C105ZFN	C 1UF, 16V	1	
C6954	TCUY1C105ZFN	C 1UF, 16V	1	
C6956	TCUY1C105ZFN	C 1UF, 16V	1	
C6958	TCUY1C105ZFN	C 1UF, 16V	1	
C6964- 66	ECJ2XB1H221K	C 220PF, K, 50V	3	
C6981	ECJ2XB1H102K	C 1000PF, K, 50V	1	
C6982	F1L2E105A013	E 0.10UF, 25V	1	
C6985	F1L2E105A013	E 0.10UF, 25V	1	
C7111	ECJ3XB2A474K	C 0.47UF, 6.3V	1	
C7112	TCUY1C105ZFN	C 1UF, 16V	1	
C7113,1 4	ECJ3XB2A474K	C 0.47UF, 6.3V	2	
C7115	TCUY1C105ZFN	C 1UF, 16V	1	
C7116	ECJ3XB2A474K	C 0.47UF, 6.3V	1	
C7117	TCUY1C105ZFN	C 1UF, 16V	1	
C7118	ECJ1XC1H101J	C 100PF, J, 50V	1	
C7120	TCUY1C105ZFN	C 1UF, 16V	1	
C7121	ECJ1XC1H101J	C 100PF, J, 50V	1	
C7126	ECJ1XB1C104K	C 0.1UF, Z, 16V	1	
C7129,3 0	ECJ1XB1C104K	C 0.1UF, Z, 16V	2	
C7132	TCUY1C105ZFN	C 1UF, 16V	1	
C7133	ECJ1XC1H101J	C 100PF, J, 50V	1	
C7135	ECJ3XB2A474K	C 0.47UF, 6.3V	1	
C7136	TCUY1C105ZFN	C 1UF, 16V	1	
C7137	ECJ3XB2A474K	C 0.47UF, 6.3V	1	
C7139	ECJ1XB1C104K	C 0.1UF, Z, 16V	1	
C7201	ECJ3XB2A474K	C 0.47UF, 6.3V	1	
C7202	TCUY1C105ZFN	C 1UF, 16V	1	
C7203,0 4	ECJ3XB2A474K	C 0.47UF, 6.3V	2	
C7205	TCUY1C105ZFN	C 1UF, 16V	1	
C7206	ECJ3XB2A474K	C 0.47UF, 6.3V	1	
C7207	TCUY1C105ZFN	C 1UF, 16V	1	
C7208	ECJ1XC1H101J	C 100PF, J, 50V	1	
C7210	ECJ3XB2A474K	C 0.47UF, 6.3V	1	
C7211	TCUY1C105ZFN	C 1UF, 16V	1	

Ref. No.	Part No.	Part Name & Description	Pcs	Remarks
C7212	ECJ3XB2A474K	C 0.47UF, 6.3V	1	
C7213	TCUY1C105ZFN	C 1UF, 16V	1	
C7214	ECJ1XC1H101J	C 100PF, J, 50V	1	
C7216	TCUY1C105ZFN	C 1UF, 16V	1	
C7217	ECJ1XC1H101J	C 100PF, J, 50V	1	
C7220	ECJ1XB1C104K	C 0.1UF, Z, 16V	1	
C7222	ECJ1XB1C104K	C 0.1UF, Z, 16V	1	
C7224	ECJ1XB1C104K	C 0.1UF, Z, 16V	1	
C7226	ECJ1XB1C104K	C 0.1UF, Z, 16V	1	
C7231	TCUY1C105ZFN	C 1UF, 16V	1	
C7232	ECJ1XC1H101J	C 100PF, J, 50V	1	
C7234	ECJ3XB2A474K	C 0.47UF, 6.3V	1	
C7235	TCUY1C105ZFN	C 1UF, 16V	1	
C7236	ECJ3XB2A474K	C 0.47UF, 6.3V	1	
C7239	ECJ1XB1C104K	C 0.1UF, Z, 16V	1	
C9028,2 9	F1J0J1060004	C 0.010UF, K, 16V	2	
C9033,3 4	ECJ1XF1C104Z	C 0.1UF, Z, 16V	2	
C9035,3 6	F1J0J1060004	C 0.010UF, K, 16V	2	
C9037	ECJ1VB1H103K	C 0.001UF, K, 50V	1	
C9039	F1J0J1060004	C 0.010UF, K, 16V	1	
C9040	ECJ1XF1C104Z	C 0.1UF, Z, 16V	1	
C9044- 53	ECJ1XF1C104Z	C 0.1UF, Z, 16V	10	
C9055	ECJ1XF1C104Z	C 0.1UF, Z, 16V	1	
C9057	ECJ1XF1C104Z	C 0.1UF, Z, 16V	1	
C9058	F1J0J1060004	C 0.010UF, K, 16V	1	
C9060	ECJ1XF1C104Z	C 0.1UF, Z, 16V	1	
C9467,6 8	ECJ1VF1H103Z	C 0.010UF, Z, 50V	2	
C9469	ECJ1XF1C104Z	C 0.1UF, Z, 16V	1	
C9500- 06	ECJ1XB1C104K	C 0.1UF, Z, 16V	7	
C9508	ECJ1XB1C104K	C 0.1UF, Z, 16V	1	
C9509	ECJ1VC1H200J	C 20PF, C, 50V	1	
C9510	ECJ1XC1H150J	C 15PF, J, 50V	1	
C9511	F1J0J1060004	C 0.010UF, K, 16V	1	
C9512	ECJ1XF1C104Z	C 0.1UF, Z, 16V	1	
C9514,1 5	ECJ2VF1C105Z	C 1UF, Z, 16V	2	
C9516- 25	ECJ1XB1C104K	C 0.1UF, Z, 16V	10	
C9526	F1J0J1060004	C 0.010UF, K, 16V	1	
C9527- 30	ECJ1XB1C104K	C 0.1UF, Z, 16V	4	
C9531	F1J0J1060004	C 0.010UF, K, 16V	1	
C9800	ECJ1XB1C104K	C 0.1UF, Z, 16V	1	
C9801	ECJ1VB1H472K	C 4700PF, K, 50V	1	
C9802	ECJ1XC1H470J	C 47PF, J, 50V	1	
C9803	ECJ1VB1H472K	C 4700PF, K, 50V	1	
C9804	ECJ1XB1C104K	C 0.1UF, Z, 16V	1	
C9805	ECJ1VB0J475K	C 4.7UF, K, 6.3V	1	
C9806	ECGRL0G680ER	C 68PF, J, 4V	1	
C9807,0 8	ECJ3YB1E106M	C 10 UF, K, 25V	2	
C9809	ECJ1XB1C104K	C 0.1UF, Z, 16V	1	
C9815,1 6	ECGRL0G680ER	C 68PF, J, 4V	2	
C9817,1 8	ECJ3YB1E106M	C 10 UF, K, 25V	2	
C9822	F1J0J1060004	C 0.010UF, K, 16V	1	
C9823,2 4	ECJ3YB1E106M	C 10 UF, K, 25V	2	
C9825	ECJ1XC1H101K	C 100PF, K, 50V	1	
C9826	ECJ1XF1C104Z	C 0.1UF, Z, 16V	1	
C9827	F1J0J1060004	C 0.010UF, K, 16V	1	
C9830- 32	ECJ3XB1C106M	C 1.0UF, K, 16V	3	
C9833	ECJ3YB1E106M	C 10 UF, K, 25V	1	
C9837	ECJ3XB1C106M	C 1.0UF, K, 16V	1	
C9838	ECJ1XF1C104Z	C 0.1UF, Z, 16V	1	
C9839	ECJ3YB1E106M	C 10 UF, K, 25V	1	
C9840	ECJ1XF1C104Z	C 0.1UF, Z, 16V	1	

Ref. No.	Part No.	Part Name & Description	Pcs	Remarks
C9841,4 2	ECJ2VF1C105Z	C 1UF, Z, 16V	2	
C9843	ECJ1XF1C104Z	C 0.1UF, Z, 16V	1	
C9844	ECJ1VF1H103Z	C 0.010UF, Z, 50V	1	
C9845,4 6	ECJ1XF1C104Z	C 0.1UF, Z, 16V	2	
C9847,4 8	ECJ1VB1E104K	C 0.10UF, K, 25V	2	
C9880,8 1	ECJ1XB1H102K	C 1000UF, Z, 50V	2	
C9882	ECJ1XB1C104K	C 0.1UF, Z, 16V	1	
C9883	ECJ1VB1H822K	C 8200PF, K, 50V	1	
C9884	ECJ1VC1H100C	C 10PF, C, 50V	1	
C9885	ECJ1XB1H102K	C 1000UF, Z, 50V	1	
C9886	ECJ1XB1C104K	C 0.1UF, Z, 16V	1	
C9887	ECJ1VB0J475K	C 4.7UF, K, 6.3V	1	
C9891	ECJ1XB1C104K	C 0.1UF, Z, 16V	1	
C9896	ECJ1XB1C104K	C 0.1UF, Z, 16V	1	
C9897	ECJ1VB1H822K	C 8200PF, K, 50V	1	
C9898	ECJ1VC1H100C	C 10PF, C, 50V	1	
C9899	ECJ1XB1H102K	C 1000UF, Z, 50V	1	
C9900- 51	ECJ1XB1C104K	C 0.1UF, Z, 16V	52	
C9952- 54	EEFCD0G560ER	56UF,	3	
C9955- 59	ECJ1XB1C104K	C 0.1UF, Z, 16V	5	
C9960- 64	ECJ3XB0J106M	C 10UF, M, 6.3V	5	
C9965	EEFCD0G560ER	56UF,	1	
C9966	ECJ1XB1C104K	C 0.1UF, Z, 16V	1	
C9967	ECJ1VB0J475K	C 4.7UF, K, 6.3V	1	
C9971	ECJ1XB1C104K	C 0.1UF, Z, 16V	1	
CB1-B7	K1MN68BA0002	68P CONNECTOR	7	
D3	K1KY40B00003	40P CONNECTOR	1	
D5	K1KB31BA0064	31P CONNECTOR	1	
D6	K1KA21A00011	21P CONNECTOR	1	
D20	K1KA20BA0296	20P CONNECTOR	1	
D25	K1KA20B00155	20P CONNECTOR	1	
D31,32	K1MN55BA0094	55P CONNECTOR	2	
D1106,0 7	MA729	DIODE	2	
D1119	MA704A	DIODE	1	
D1121	MA729	DIODE	1	
D2011- 14	MA111	DIODE	4	
D2119	BOBC01100001	ZENER DIODE	1	
D2300,0 1	MA111	DIODE	2	
D2303,0 4	MA111	DIODE	2	
D2309	MA111	DIODE	1	
D2512	MA8056-M	ZENER DIODE	1	
D2521	MA152K	DIODE	1	
D2524	MA8056-M	ZENER DIODE	1	
D2529	MA8056-M	ZENER DIODE	1	
D2530	B3AGA0000072	DIODE	1	
D3003	MA8140M	ZENER DIODE	1	
D3005,0 6	MA8140M	ZENER DIODE	2	
D3017	MA8140M	ZENER DIODE	1	
D3021- 23	MA111	DIODE	3	
D3024	BOBC01100001	ZENER DIODE	1	
D3038- 43	MA8140M	ZENER DIODE	6	
D3044	MA111	DIODE	1	
D3045- 49	MA8140M	ZENER DIODE	5	
D3100	MA8140M	ZENER DIODE	1	
D4020	EZJZ0V80008B	VARISTOR	1	
D4022	EZJZ0V80008B	VARISTOR	1	
D4024	EZJZ0V80008B	VARISTOR	1	
D4026	EZJZ0V80008B	VARISTOR	1	

Ref. No.	Part No.	Part Name & Description	Pcs	Remarks
D4028	EZJZ0V80008B	VARISTOR	1	
D4031,3 2	EZJZ0V80008B	VARISTOR	2	
D4035,3 6	EZJZ0V80008B	VARISTOR	2	
D4038	EZJZ0V80008B	VARISTOR	1	
D4041	EZJZ0V80008B	VARISTOR	1	
D4044	EZJZ0V80008B	VARISTOR	1	
D4047	MA3056M	ZENER DIODE	1	
D4049,5 0	BOHMM000014	DIODE	2	
D5606	BOBC01100001	ZENER DIODE	1	
D5607	BOBC6R600005	ZENER DIODE	1	
D5610	BOBC4R700007	ZENER DIODE	1	(PA)
D5610	MA3X78900L	ZENER DIODE	1	(H)
D5612	BOBC3R700006	ZENER DIODE	1	
D5618	BOBC03900015	ZENER DIODE	1	
D5634	MA111	DIODE	1	
D5635	MA3047H	ZENER DIODE	1	
D5637,3 8	MA152	DIODE	2	
D5639	MA3047H	ZENER DIODE	1	
D5640	MA3039H	ZENER DIODE	1	
D5641	MA152	DIODE	1	
D5642	MA3120M	ZENER DIODE	1	
D5643	MA152	DIODE	1	
D5644	MA3068M	ZENER DIODE	1	
D5646,4 7	MA152	DIODE	2	
D5649	MA111	DIODE	1	
D6001	BOHBSN000008	DIODE	1	
D6021	BOHBSN000008	DIODE	1	
D6041	BOEHP000003	DIODE	1	
D6051	BOEHP000003	DIODE	1	
D6061	BOHBSN000008	DIODE	1	
D6071	BOHBSN000008	DIODE	1	
D6072	BOEHP000003	DIODE	1	
D6081	BOHBSN000008	DIODE	1	
D6091	BOHBSN000008	DIODE	1	
D6092	BOEHP000003	DIODE	1	
D6101,0 2	BOJCME000037	DIODE	2	
D6131,3 2	BOEHP000003	DIODE	2	
D6151,5 2	BOEHP000003	DIODE	2	
D6153	MA111	DIODE	1	
D6154	MA8033L	ZENER DIODE	1	
D6191- 93	BOEHP000003	DIODE	3	
D6211	BOJCME000037	DIODE	1	
D6213,1 4	MA111	DIODE	2	
D6215	MA8082MTX	ZENER DIODE	1	
D6221	BOEHP000003	DIODE	1	
D6222,2 3	MA111	DIODE	2	
D6251,5 2	MA8330M	ZENER DIODE	2	
D6253	LNJ301MPUJA	LED	1	
D6254	MA8051L	ZENER DIODE	1	
D6255	MA111	DIODE	1	
D6401	BOHBSN000008	DIODE	1	
D6431	MA3DF40000LZ	DIODE	1	
D6441	BOEHP000003	DIODE	1	
D6451	BOEHP000003	DIODE	1	
D6461	BOHBSN000008	DIODE	1	
D6471	BOHBSN000008	DIODE	1	
D6472	BOEHP000003	DIODE	1	
D6477	MA111	DIODE	1	
D6478	BOHCKS000002	DIODE	1	
D6480	MA111	DIODE	1	
D6481	BOHBSN000008	DIODE	1	
D6491	MA3DF40000LZ	DIODE	1	
D6497	MA111	DIODE	1	

Ref. No.	Part No.	Part Name & Description	Pcs	Remarks
D6501,02	B0ECHP000003	DIODE	2	
D6521,22	B0ECHP000003	DIODE	2	
D6523	MA111	DIODE	1	
D6524	MA8033L	ZENER DIODE	1	
D6581,82	MA8330M	ZENER DIODE	2	
D6583	LNJ301MPUJA	LED	1	
D6584	MA8051L	ZENER DIODE	1	
D6585	MA111	DIODE	1	
D6601	MA8240M	ZENER DIODE	1	
D6602	B0ECHP000003	DIODE	1	
D6603	MA8240M	ZENER DIODE	1	
D6604	MA111	DIODE	1	
D6605	MA8051L	ZENER DIODE	1	
D6606	B0HCMM000014	DIODE	1	
D6607	MA111	DIODE	1	
D6610	MAZ81500ML	ZENER DIODE	1	
D6611-14	MA111	DIODE	4	
D6619,20	B0HCKS000002	DIODE	2	
D6621	B0HDSM000005	DIODE	1	
D6623	B0HDSM000005	DIODE	1	
D6641,42	B0HCKS000002	DIODE	2	
D6643	B0JCME000037	DIODE	1	
D6644	B0HCKS000002	DIODE	1	
D6661	MA111	DIODE	1	
D6662-64	MA8330M	ZENER DIODE	3	
D6665	MA8051L	ZENER DIODE	1	
D6666,67	MA111	DIODE	2	
D6671	MA111	DIODE	1	
D6682	B0HCMM000014	DIODE	1	
D6683,84	MA111	DIODE	2	
D6686,87	MA111	DIODE	2	
D6701,02	MA8056H	ZENER DIODE	2	
D6721	B0HCKS000002	DIODE	1	
D6723,24	B0JCME000037	DIODE	2	
D6725	B0ECHP000003	DIODE	1	
D6726-33	MA8056H	ZENER DIODE	8	
D6734	MA111	DIODE	1	
D6752	B0JCME000037	DIODE	1	
D6758	B0ECHP000003	DIODE	1	
D6760,61	MA111	DIODE	2	
D6771	B0JCME000037	DIODE	1	
D6773	B0HCKS000002	DIODE	1	
D6791	MA8200M	ZENER DIODE	1	
D6801	B0JCME000037	DIODE	1	
D6803	MA111	DIODE	1	
D6804	B0ECHP000003	DIODE	1	
D6805	MA111	DIODE	1	
D6806	B0ECHP000003	DIODE	1	
D6820-23	MA111	DIODE	4	
D6825	MA8330M	ZENER DIODE	1	
D6826	MA111	DIODE	1	
D6841	B0ECHP000003	DIODE	1	
D6842,43	MA111	DIODE	2	
D6859	B0ECHP000003	DIODE	1	
D6860	B0HCKS000002	DIODE	1	
D6861	MA8051L	ZENER DIODE	1	
D6862	MA111	DIODE	1	
D6871	MA8051L	ZENER DIODE	1	
D6872	MA111	DIODE	1	

Ref. No.	Part No.	Part Name & Description	Pcs	Remarks
D6901,02	MA8056H	ZENER DIODE	2	
D6903,04	B0ECHP000003	DIODE	2	
D6921	B0ECHP000003	DIODE	1	
D6922	MA8056H	ZENER DIODE	1	
D6951,52	MA8056H	ZENER DIODE	2	
D6953,54	B0ECHP000003	DIODE	2	
D9017-19	MA3033	ZENER DIODE	3	
D9020	MA728	DIODE	1	
D9100-03	B0JCGD000002	DIODE	4	
D9105,06	B0JCGD000002	DIODE	2	
D9110	B0JCGD000002	DIODE	1	
D9300,01	MA152K	DIODE	2	
D9800	B0JCME000037	DIODE	1	
D9801	B0JCDD000002	DIODE	1	
D9802	MA728	DIODE	1	
D9804	MA152K	DIODE	1	
D9807,08	MA152K	DIODE	2	
D9811	MA728	DIODE	1	
D9812	B0JCME000037	DIODE	1	
D9813	B0JCDD000002	DIODE	1	
D9814	B0JCME000037	DIODE	1	
D9815	B0JCDD000002	DIODE	1	
DG1	K1KY80A00011	80P CONNECTOR	1	
DG2	K1KA15B00074	15P CONNECTOR	1	
DG3	K1KY40B00003	40P CONNECTOR	1	
DG5	K1KB21BA0063	21P CONNECTOR	1	
DG9	K1FY119D0001	CONNECTOR	1	
DG15	K1KY40B00003	40P CONNECTOR	1	
DG20	K1MN40B00045	40P CONNECTOR	1	
DG35	K1KA07BA0047	7P CONNECTOR	1	
FL7101	J0HABH000013	LC FILTER	1	
FL7201	J0HABH000013	LC FILTER	1	
FL9300,01	F1J1E1040022	C 0.10UF, Z, 25V	2	
FL9800,01	J0HABH000013	LC FILTER	2	
FL9803,04	J0HABH000012	LC FILTER	2	
FL9805-07	J0HABH000013	LC FILTER	3	
FL9900-02	F1J1E1040022	C 0.10UF, Z, 25V	3	
FL9903,04	J0HABH000013	LC FILTER	2	
H1	K1KY80A00011	80P CONNECTOR	1	
H2	K1KA15A00148	15P CONNECTOR	1	
H5,H6	K1KA15AA0288	15P CONNECTOR	2	
H15	K1KA04AA0150	4P CONNECTOR	1	
H40	K1KA20AA0009	20P CONNECTOR	1	
H53	K1KA12AA0194	12P CONNECTOR	1	
HC01	K1KA21A00011	21P CONNECTOR	1	
HC12	K1KA09AA0190	9P CONNECTOR	1	
HC15	K1KY40B00003	40P CONNECTOR	1	
HC21	K1KA08AA0193	8P CONNECTOR	1	
HC22	K1KA11AA0194	11P CONNECTOR	1	
IC1100	C3ABPG000155	IC	1	
IC1101	TVRN938	IC	1	
IC1102	TVRN773	IC	1	
IC1103	MN103SB20RGL	IC	1	
IC1110	C0CBCAD00016	IC	1	
IC1111	C0EBY0000041	IC	1	
IC2103	AN77L08M	IC	1	

Ref. No.	Part No.	Part Name & Description	Pcs	Remarks
IC2104	C0ABBA000168	IC	1	
IC2105	AN15862A-VT	IC	1	
IC2106	ClAB00002468	IC	1	
IC2302	ClAB00002451	IC	1	
IC2304	C0ABBA000168	IC	1	
IC2306	C0ABBA000168	IC	1	
IC3005	AN15867A-VT	IC	1	
IC4013	C0CBCBF00009	IC	1	
IC4016	C0CBCAC00275	IC	1	
IC4018	C0CBCAC00275	IC	1	
IC4019	ClAB00002456	IC	1	
IC4023	TVRN918	IC	1	
IC4025	C0FBK000038	IC	1	
IC4026	ClAB00002535	IC	1	
IC4027	C0DBFFD00003	IC	1	
IC4028	C0ABBB000230	IC	1	
IC4029	C0CBCAC00282	IC	1	
IC4030	C0CBCBC00190	IC	1	
IC4032	C0DBGYY00052	IC	1	
IC4035	C0CBCAF00031	IC	1	
IC4036	C0JBAP000020	IC	1	
IC4037	MN84522-A	IC	1	
IC4038	C3ABQJ000051	IC	1	
IC5601	NOBG2DE00001	IC	1	
IC5602	EHMDD9851	LINEAR IC	1	
IC5603	C0DBAJB00004	IC	1	
IC5604	C0DBZGC00067	IC	1	
IC6131	COZBZ0000895	IC	1	
IC6151	COZBZ0000895	IC	1	
IC6191	COZBZ0000895	IC	1	
IC6211	COZBZ0001325	IC	1	
IC6221	C0DBEMB00005	IC	1	
IC6241	C0JBAZ000005	IC	1	
IC6251	NJM2903M	INTEGRATED CIRCUIT	1	
IC6471	C0DBEKA00003	IC	1	
IC6472	C0JBAA000377	IC	1	
IC6501	COZBZ0000895	IC	1	
IC6521	COZBZ0000895	IC	1	
IC6561, 62	C0JBAZ000005	IC	2	
IC6581	NJM2903M	INTEGRATED CIRCUIT	1	
IC6601	COZBZ0001325	IC	1	
IC6602	C0JBAB000715	IC	1	
IC6610	NJM2903M	INTEGRATED CIRCUIT	1	
IC6671	COZBZ0001325	IC	1	
IC6681	COZBZ0001325	IC	1	
IC6682	C0JBAA000377	IC	1	
IC6721, 22	C0JBAZ000994	IC	2	
IC6724, 25	C0CBADC00089	IC	2	
IC6751	C0CBADC00089	IC	1	
IC6752	COZBZ0001325	IC	1	
IC6753	C0JBAB000715	IC	1	
IC6771	C0CBADC00089	IC	1	
IC6772	COZBZ0001325	IC	1	
IC6773, 74	C0JBAA000377	IC	2	
IC6791	N0BF1FB00001	IC	1	
IC6801, 02	C0DBEMB00005	IC	2	
IC6821	C0DBEMB00005	IC	1	
IC6841	C0DBEMB00005	IC	1	
IC6861	NJM2903M	INTEGRATED CIRCUIT	1	
IC6871	NJM2903M	INTEGRATED CIRCUIT	1	
IC6901-04	AN16071A-VT	IC	4	
IC6951-54	AN16071A-VT	IC	4	
IC7101-04	C0JBAZ001120	IC	4	
IC7201-05	C0JBAZ001120	IC	5	
IC9001	TVRN806	IC	1	
IC9003	TVRN992	IC	1	

Ref. No.	Part No.	Part Name & Description	Pcs	Remarks
IC9007	TVRN941	IC	1	
IC9011	C0EBF0000431	IC	1	
IC9200	ClZBZ0003185	IC	1	
IC9303	TVRN815	IC	1	
IC9500	ClZBZ0002599	IC	1	
IC9502	PST9128NR	IC (LOGIC)	1	
IC9503, 04	C0JBAZ001120	IC	2	
IC9800	C0DBAYY00054	IC	1	
IC9801	C0DBZFG00066	IC	1	
IC9802, 03	C0JBAZ001120	IC	2	
IC9806	C0DBAHD00011	IC	1	
IC9807	C0DBAYY00054	IC	1	
IC9809	C0DBAYY00054	IC	1	
IC9900	MN84521-A	IC	1	
IC9901	C3ABQJ000051	IC	1	
JK2003	K2HA204A0038	JACK	1	
JK3100	TJB0A639	TERMINAL	1	
JS003	ERJ3GEY0R00	M 0 OHM, 1/16W	1	
JS1100-02	ERJ2GE0R00	M 0.0 OHM, J,0.063W	3	
JS1109	ERJ2GE0R00	M 0.0 OHM, J,0.063W	1	
JS1116	ERJ2GE0R00	M 0.0 OHM, J,0.063W	1	
JS2021, 22	ERJ3GEY0R00	M 0 OHM, 1/16W	2	
JS2026	ERJ3GEY0R00	M 0 OHM, 1/16W	1	
JS2031-33	ERJ3GEY0R00	M 0 OHM, 1/16W	3	
JS2108, 09	ERJ3GEY0R00	M 0 OHM, 1/16W	2	
JS2123, 24	ERJ3GEY0R00	M 0 OHM, 1/16W	2	
JS2300-03	ERJ6GEY0R00	M 0 OHM, 1/10W	4	
JS2319	ERJ6GEY0R00	M 0 OHM, 1/10W	1	
JS2331	ERJ6GEY0R00	M 0 OHM, 1/10W	1	
JS3001	ERJ3GEY0R00	M 0 OHM, 1/16W	1	
JS3010-15	ERJ6GEY0R00	M 0 OHM, 1/10W	6	
JS3023	ERJ3GEY0R00	M 0 OHM, 1/16W	1	
JS3206	ERJ3GEY0R00	M 0 OHM, 1/16W	1	
JS3215	ERJ6GEY0R00	M 0 OHM, 1/10W	1	
JS3239	ERJ3GEY0R00	M 0 OHM, 1/16W	1	
JS3246	ERJ6GEY0R00	M 0 OHM, 1/10W	1	
JS3252	ERJ6GEY0R00	M 0 OHM, 1/10W	1	
JS3255	ERJ6GEY0R00	M 0 OHM, 1/10W	1	
JS3256	ERJ3GEY0R00	M 0 OHM, 1/16W	1	
JS3265, 66	ERJ3GEY0R00	M 0 OHM, 1/16W	2	
JS3302-04	ERJ3GEY0R00	M 0 OHM, 1/16W	3	
JS3352	J0JCC0000241	CHIP INDUCTOR	1	
JS3354, 55	J0JCC0000241	CHIP INDUCTOR	2	
JS3357	J0JCC0000241	CHIP INDUCTOR	1	
JS3359	J0JCC0000241	CHIP INDUCTOR	1	
JS3368	ERJ3GEY0R00	M 0 OHM, 1/16W	1	
JS3402, 03	ERJ3GEY0R00	M 0 OHM, 1/16W	2	
JS3404, 05	ERJ6GEY0R00	M 0 OHM, 1/10W	2	
JS4016, 17	ERJ2GE0R00	M 0.0 OHM, J,0.063W	2	
JS4022-24	ERJ2GE0R00	M 0.0 OHM, J,0.063W	3	
JS4025, 26	ERJ2GEJ101	M 100 OHM, J,0.063W	2	
JS4027, 28	ERJ2GE0R00	M 0.0 OHM, J,0.063W	2	
JS4029	ERJ2GEJ221	M 220 OHM, J,0.063W	1	

Ref. No.	Part No.	Part Name & Description	Pcs	Remarks
JS4033-40	ERJ2GE0R00	M 0.0 OHM, J,0.063W	8	
JS4046	ERJ2GE0R00	M 0.0 OHM, J,0.063W	1	
JS4069	ERJ2GEJ221	M 220 OHM, J,0.063W	1	
JS4103,04	ERJ2GE0R00	M 0.0 OHM, J,0.063W	2	
JS4111	ERJ3GEY0R00	M 0 OHM, 1/16W	1	
JS4131	ERJ2GE0R00	M 0.0 OHM, J,0.063W	1	
JSS5600	ERJ3GEY0R00	M 0 OHM, 1/16W	1	
JSS5602	ERJ3GEY0R00	M 0 OHM, 1/16W	1	
K1	K1KY12B00001	12P CONNECTOR	1	
L008	J0JCC0000241	CHIP INDUCTOR	1	
L012	J0JCC0000241	CHIP INDUCTOR	1	
L017,18	J0JCC0000241	CHIP INDUCTOR	2	
L021	J0JCC0000241	CHIP INDUCTOR	1	
L022	J0JGC0000021	CHIP INDUCTOR COIL	1	
L1101-04	J0JHC0000078	CHIP INDUCTOR	4	
L1109	J0JHC0000078	CHIP INDUCTOR	1	
L2001,02	J0JCC0000364	CHIP INDUCTOR	2	
L2003,04	TSK1032	BEAD CHOKE	2	
L2007,08	TSK1032	BEAD CHOKE	2	
L2011,12	TSK1032	BEAD CHOKE	2	
L2015,16	TSK1032	BEAD CHOKE	2	
L2107	TSK1032	BEAD CHOKE	1	
L2108	J0JCC0000241	CHIP INDUCTOR	1	
L2109,10	TSK1032	BEAD CHOKE	2	
L2111,12	J0JCC0000241	CHIP INDUCTOR	2	
L2115	J0JCC0000241	CHIP INDUCTOR	1	
L2117	ELESE6R8KA	PEAKING COIL	1	
L2118	EXCELD3R35C	BEAD CHOKE	1	
L2123	J0JCC0000241	CHIP INDUCTOR	1	
L2182-87	J0JCC0000241	CHIP INDUCTOR	6	
L2204	ERJ3GEY0R00	M 0 OHM, 1/16W	1	
L2205,06	J0JCC0000241	CHIP INDUCTOR	2	
L2300-03	G0C330MA0049	PEAKING COIL	4	
L2308	TALL08N3R9MA	INDUCTION COIL	1	
L3000	G0C101K00023	PEAKING COIL	1	
L3001-03	TSK1032	BEAD CHOKE	3	
L3009,10	TSK1032	BEAD CHOKE	2	
L3013	TSK1032	BEAD CHOKE	1	
L3026	TSK1032	BEAD CHOKE	1	
L3201	TSK1040	FERRITE CORE	1	
L3212	TSK1032	BEAD CHOKE	1	
L3216	J0JGC0000021	CHIP INDUCTOR COIL	1	
L4023	J0JHC0000078	CHIP INDUCTOR	1	
L4029	J0JHC0000078	CHIP INDUCTOR	1	
L4031	J0JHC0000078	CHIP INDUCTOR	1	
L4038	J0JHC0000078	CHIP INDUCTOR	1	
L4041	J0JHC0000078	CHIP INDUCTOR	1	
L4044-46	J0JHC0000078	CHIP INDUCTOR	3	
L4048	J0JHC0000078	CHIP INDUCTOR	1	
L4049	J0JBC0000080	CHIP INDUCTOR	1	
L4050,51	J0JHC0000078	CHIP INDUCTOR	2	
L4052	J0JCC0000077	CHIP INDUCTOR	1	
L4053-55	J0JHC0000078	CHIP INDUCTOR	3	

Ref. No.	Part No.	Part Name & Description	Pcs	Remarks
L4056,57	J0JCC0000077	CHIP INDUCTOR	2	
L4060,61	J0JCC0000077	CHIP INDUCTOR	2	
L4065,66	J0JHC0000078	CHIP INDUCTOR	2	
L4068-70	J0JHC0000078	CHIP INDUCTOR	3	
L4071	J0JBC0000080	CHIP INDUCTOR	1	
L4073	J0JHC0000078	CHIP INDUCTOR	1	
L4075	J0JHC0000078	CHIP INDUCTOR	1	
L4077	J0JCC0000077	CHIP INDUCTOR	1	
L4078	J0JHC0000078	CHIP INDUCTOR	1	
L5602	TALL08N2R7MA	INDUCTION COIL	1	
L5604	TALL08N2R7MA	INDUCTION COIL	1	
L5605	G0A2R7ZA0021	CHOKE COIL	1	
L5606,07	G0A220GA0002	CHOKE COIL	2	
L5608	G1C100MA0072	INDUCTION COIL	1	
L5609	G0A220GA0002	CHOKE COIL	1	
L5610	G1C470MA0077	INDUCTION COIL	1	
L5612	TALL08N2R7MA	INDUCTION COIL	1	
L5615	TALL08N150KA	INDUCTION COIL	1	
L5621	G1C330MA0234	INDUCTION COIL	1	
L5622,23	G1C150MA0234	INDUCTION COIL	2	
L5624	G1C330MA0234	INDUCTION COIL	1	
L5651	G0A220GA0002	CHOKE COIL	1	
L6001-03	ELC11P0R6	CHOKE COIL	3	
L6011	ELC11P1R0	CHOKE COIL	1	
L6013	ELC11P1R0	CHOKE COIL	1	
L6061-64	G0ZZ00002183	PEAKING COIL	4	
L6081-84	G0ZZ00002183	PEAKING COIL	4	
L6101,02	J0JJC0000011	CHIP INDUCTOR	2	
L6103	G0ZZ00002183	PEAKING COIL	1	
L6221	G0ZZ00002183	PEAKING COIL	1	
L6241	G0ZZ00002183	PEAKING COIL	1	
L6262	G0ZZ00002183	PEAKING COIL	1	
L6271	G0ZZ00002183	PEAKING COIL	1	
L6401-03	ELC11P0R6	CHOKE COIL	3	
L6411,12	ELC11P1R0	CHOKE COIL	2	
L6461-64	G0ZZ00002183	PEAKING COIL	4	
L6472	G0ZZ00002183	PEAKING COIL	1	
L6481-84	G0ZZ00002183	PEAKING COIL	4	
L6591,92	G0ZZ00002183	PEAKING COIL	2	
L6602	G0ZZ00002183	PEAKING COIL	1	
L9500	G1C150KA0038	INDUCTION COIL	1	
L9501,02	J0JHC0000078	CHIP INDUCTOR	2	
L9800	G1C3ROMA0248	INDUCTION COIL	1	
L9801,02	G1C2R2MA0241	INDUCTION COIL	2	
L9810	J0JHC0000045	CHIP INDUCTOR	1	
PA2	K1KA05AA0192	5P CONNECTOR	1	
PA5	K1KA11AA0194	11P CONNECTOR	1	
PA10	K1KA06A00452	6P CONNECTOR	1	
PA20	K1MN40A00024	40P CONNECTOR	1	
PA40	K1KA20AA0009	20P CONNECTOR	1	
PA1101	K5H8012A0023	FUSE	1	
PA2055	K5H1622A0023	FUSE	1	
PA3100	K5H1622A0023	FUSE	1	
PA3104	ERJ3GEY0R00	M 0 OHM, 1/16W	1	
PA9800	K5H4022A0023	FUSE	1	
PC6480	B3PBA0000223	IC	1	

Ref. No.	Part No.	Part Name & Description	Pcs	Remarks
PC6701-03	B3PBA0000233	IC	3	
PC6704	K7GBZEE00007	PHOTO COUPLER	1	
PC6705	B3PBA0000233	IC	1	
PC6760	B3PBA0000223	IC	1	
PC6801	B3PBA0000223	IC	1	
PC6861	B3PBA0000223	IC	1	
PC6871	B3PBA0000223	IC	1	
Q002	2SA207700L	TRANSISTOR	1	
Q1100,01	2SC584500L	TRANSISTOR	2	
Q1103	2SC584500L	TRANSISTOR	1	
Q1108	2SC584500L	TRANSISTOR	1	
Q1109,10	B1CBHD000002	FET	2	
Q1111	2SC584500L	TRANSISTOR	1	
Q1113-16	2SC584500L	TRANSISTOR	4	
Q1130	2SC584500L	TRANSISTOR	1	
Q1134	2SC584500L	TRANSISTOR	1	
Q1137	2SC584500L	TRANSISTOR	1	
Q1139-43	2SC584500L	TRANSISTOR	5	
Q2001,02	2SC584500L	TRANSISTOR	2	
Q2011	2SA207700L	TRANSISTOR	1	
Q2012	2SC584500L	TRANSISTOR	1	
Q2013	2SA207700L	TRANSISTOR	1	
Q2102-05	2SA207700L	TRANSISTOR	4	
Q2106	2SC584500L	TRANSISTOR	1	
Q2108	2SC584500L	TRANSISTOR	1	
Q2113,14	2SC584500L	TRANSISTOR	2	
Q230002	2SA207700L	TRANSISTOR	1	
Q2300	2SC584500L	TRANSISTOR	1	
Q2301	2SD601A	TRANSISTOR	1	
Q230102	2SD601A	TRANSISTOR	1	
Q2302	2SC584500L	TRANSISTOR	1	
Q2303	2SD601A	TRANSISTOR	1	
Q2306,07	2SA207700L	TRANSISTOR	2	
Q2314-17	2SC584500L	TRANSISTOR	4	
Q2510,11	2SD601A	TRANSISTOR	2	
Q2513	2SD601A	TRANSISTOR	1	
Q2519,20	2SB709A	TRANSISTOR	2	
Q3002	2SA207700L	TRANSISTOR	1	
Q3008	2SA207700L	TRANSISTOR	1	
Q3011	2SA207700L	TRANSISTOR	1	
Q3014,15	2SA207700L	TRANSISTOR	2	
Q3017	2SA207700L	TRANSISTOR	1	
Q3204,05	2SC584500L	TRANSISTOR	2	
Q4050	2SC584500L	TRANSISTOR	1	
Q4053	2SC584500L	TRANSISTOR	1	
Q4055-59	2SA207700L	TRANSISTOR	5	
Q4061-64	2SC584500L	TRANSISTOR	4	
Q4066,67	2SC584500L	TRANSISTOR	2	
Q4069	2SC584500L	TRANSISTOR	1	
Q4070	B1MBACA00008	TRANSISTOR	1	
Q4082	2SK1228	FET	1	
Q4919	2SC584500L	TRANSISTOR	1	
Q5601	B1DHDC000028	TRANSISTOR	1	
Q5602	2SD601A	TRANSISTOR	1	
Q5603	B1DHDC000028	TRANSISTOR	1	
Q5604,05	2SD601A	TRANSISTOR	2	

Ref. No.	Part No.	Part Name & Description	Pcs	Remarks
Q5610	2SD601A	TRANSISTOR	1	
Q5613	2SD601A	TRANSISTOR	1	
Q5614	2SK3065T100	FET	1	
Q5641-43	2SA207700L	TRANSISTOR	3	
Q5644	2SD601A	TRANSISTOR	1	
Q6001-03	2PG0010000RP	TRANSISTOR	3	
Q6021-23	2PG0010000RP	TRANSISTOR	3	
Q6041,42	2PG0010000RP	TRANSISTOR	2	
Q6051	2PG0010000RP	TRANSISTOR	1	
Q6101,02	B1DFKM000002	TRANSISTOR	2	
Q6111	2SK326800L	FET	1	
Q6112	B1DFKM000002	TRANSISTOR	1	
Q6141	B1ABNF000006	TRANSISTOR	1	
Q6142	B1ADNF000006	TRANSISTOR	1	
Q6146	B1ABNF000006	TRANSISTOR	1	
Q6147	B1ADNF000006	TRANSISTOR	1	
Q6212	2SD601A	TRANSISTOR	1	
Q6221	2SD1263A	TRANSISTOR	1	
Q6222	2SC1473A	TRANSISTOR	1	
Q6251	2SD601A	TRANSISTOR	1	
Q6401-03	2PG0010000RP	TRANSISTOR	3	
Q6421-23	2PG0020000RP	TRANSISTOR	3	
Q6441,42	2PG0010000RP	TRANSISTOR	2	
Q6451	2PG0020000RP	TRANSISTOR	1	
Q6471	B1CHGD000006	TRANSISTOR	1	
Q6511	B1ABNF000006	TRANSISTOR	1	
Q6512	B1ADNF000006	TRANSISTOR	1	
Q6516	B1ABNF000006	TRANSISTOR	1	
Q6517	B1ADNF000006	TRANSISTOR	1	
Q6581	2SD601A	TRANSISTOR	1	
Q6601	B1DFES000003	TRANSISTOR	1	
Q6602	2SD601A	TRANSISTOR	1	
Q6621,22	2SK399500L	FET	2	
Q6642-44	2SK399500L	FET	3	
Q6646-48	2SK399500L	FET	3	
Q6661	B1DEET000002	TRANSISTOR	1	
Q6662	2SD601A	TRANSISTOR	1	
Q6663	2SD2185	TRANSISTOR	1	
Q6671	B1DFES000003	TRANSISTOR	1	
Q6680	B1ADNF000006	TRANSISTOR	1	
Q6681,82	2SK389500L	FET	2	
Q6691	2SK620	FET	1	
Q6742,43	2SD601A	TRANSISTOR	2	
Q6744	2SK620	FET	1	
Q6762	B1ADNF000006	TRANSISTOR	1	
Q6781	B1ABNF000006	TRANSISTOR	1	
Q6782	B1ADNF000006	TRANSISTOR	1	
Q6791	2SD601A	TRANSISTOR	1	
Q6801	B1BAEJ000014	TRANSISTOR	1	
Q6802	2SB709A	TRANSISTOR	1	
Q6803	2SD814A	TRANSISTOR	1	
Q6821	2SD1263A	TRANSISTOR	1	
Q6822	2SC3063	TRANSISTOR	1	
Q6824	2SD601A	TRANSISTOR	1	
Q6841	2SD1263A	TRANSISTOR	1	
Q6842	2SC1473A	TRANSISTOR	1	
Q6921	2SK620	FET	1	
Q9010	2SD601A	TRANSISTOR	1	
Q9044	2SD601A	TRANSISTOR	1	
Q9046	2SD601A	TRANSISTOR	1	
Q9049	2SB709A	TRANSISTOR	1	
Q9050-54	2SD601A	TRANSISTOR	5	

Ref. No.	Part No.	Part Name & Description	Pcs	Remarks
Q9055-58	B1CBHD000002	FET	4	
Q9300-02	2SD601A	TRANSISTOR	3	
Q9800,01	B1MBEDA00015	TRANSISTOR	2	
Q9803	B1MBEDA00015	TRANSISTOR	1	
Q9805,06	2SD601A	TRANSISTOR	2	
R002	ERJ3GEYJ221	M 220 OHM,J,1/16W	1	
R005	ERJ3GEYJ561	M 560 OHM,J,1/16W	1	
R008,09	ERJ3GEY0R00	M 0 OHM, 1/16W	2	
R011	ERJ6GEYJ271	M 270 OHM,J,1/10W	1	
R012,13	ERJ3GEYJ220	M 22 OHM,J,1/16W	2	
R014	ERJ3GEYJ221	M 220 OHM,J,1/16W	1	
R015	ERJ3GEY0R00	M 0 OHM, 1/16W	1	
R1101	ERJ2GEJ101	M 100 OHM, J,0.063W	1	
R1102,03	ERJ2GEJ102	M 1KOHM, J,0.063W	2	
R1105,06	ERJ2GEJ102	M 1KOHM, J,0.063W	2	
R1113	ERJ2GEJ332	M 3.3KOHM, J,0.063W	1	
R1116	ERJ2GEJ562	M 5.6KOHM,J,0.063W	1	
R1117	ERJ2GE0R00	M 0.0 OHM, J,0.063W	1	
R1118,19	EXB2HV680J	RESISTOR ARRAY	2	
R1121,22	ERJ2GEJ220	M 22 OHM, J,0.063W	2	
R1123	ERJ2GEJ473	M 47KOHM,J,0.063W	1	
R1124,25	ERJ2GEJ332	M 3.3KOHM, J,0.063W	2	
R1129,30	ERJ2GEJ473	M 47KOHM,J,0.063W	2	
R1131,32	ERJ2GEJ101	M 100 OHM, J,0.063W	2	
R1133,34	ERJ2GEJ102	M 1KOHM, J,0.063W	2	
R1135	ERJ2GEJ103	M 10KOHM, J,0.063W	1	
R1140,41	ERJ2GEJ680	M 68 OHM, J,0.063W	2	
R1146	ERJ2GEJ271	M 270 OHM, J,0.063W	1	
R1147,48	D1HG5608A002	NETWORK RESISTER	2	
R1149	EXB2HV680J	RESISTOR ARRAY	1	
R1151	ERJ2GEJ101	M 100 OHM, J,0.063W	1	
R1152	ERJ2GEJ102	M 1KOHM, J,0.063W	1	
R1153	ERJ2GEJ101	M 100 OHM, J,0.063W	1	
R1154,55	ERJ2GEJ472	M 4.7KOHM, J,0.063W	2	
R1156	ERJ2GEJ104	M 100KOHM, J,0.063W	1	
R1157	ERJ2GEJ101	M 100 OHM, J,0.063W	1	
R1158	ERJ2GEJ273	M 27KOHM ,J,0.063W	1	
R1159	ERJ2GEJ123X	M 12KOHM ,J,0.063W	1	
R1160	ERJ2GEJ473	M 47KOHM,J,0.063W	1	
R1162	ERJ2GEJ473	M 47KOHM,J,0.063W	1	
R1164	ERJ2GEJ123X	M 12KOHM ,J,0.063W	1	
R1165	ERJ2GEJ153	M 15KOHM ,J,0.063W	1	
R1168,69	ERJ2GE0R00	M 0.0 OHM, J,0.063W	2	
R1174	ERJ2GEJ101	M 100 OHM, J,0.063W	1	
R1175	ERJ2GEJ563	M 56KOHM ,J,0.063W	1	
R1176	ERJ2GEJ123X	M 12KOHM ,J,0.063W	1	
R1177-79	ERJ2GEJ101	M 100 OHM, J,0.063W	3	
R1181	ERJ2GEJ101	M 100 OHM, J,0.063W	1	
R1182	ERJ2GEJ683	M 68KOHM, J,0.063W	1	
R1183	EXB28V680JX	RESISTOR ARRAY	1	

Ref. No.	Part No.	Part Name & Description	Pcs	Remarks
R1184	ERJ2GE0R00	M 0.0 OHM, J,0.063W	1	
R1186	ERJ2GEJ473	M 47KOHM,J,0.063W	1	
R1187	EXB2HV680J	RESISTOR ARRAY	1	
R1188	ERJ2GEJ103	M 10KOHM, J,0.063W	1	
R1191	ERJ2GEJ473	M 47KOHM,J,0.063W	1	
R1192	ERJ2GEJ472	M 4.7KOHM, J,0.063W	1	
R1197-99	ERJ2GEJ473	M 47KOHM,J,0.063W	3	
R1200	EXB2HV680J	RESISTOR ARRAY	1	
R1203	ERJ2GEJ102	M 1KOHM, J,0.063W	1	
R1206	ERJ2GEJ473	M 47KOHM,J,0.063W	1	
R1207	ERJ2GEJ104	M 100KOHM, J,0.063W	1	
R1212	ERJ2GE0R00	M 0.0 OHM, J,0.063W	1	
R1214	ERJ2GEJ103	M 10KOHM, J,0.063W	1	
R1215-17	ERJ2GEJ101	M 100 OHM, J,0.063W	3	
R1218	ERJ2GEJ680	M 68 OHM, J,0.063W	1	
R1220	ERJ2GEJ680	M 68 OHM, J,0.063W	1	
R1221	ERJ2GEJ332	M 3.3KOHM, J,0.063W	1	
R1222	ERJ2GEJ330	M 33 OHM, J,0.063W	1	
R1223	ERJ2GEJ102	M 1KOHM, J,0.063W	1	
R1224	ERJ2GEJ473	M 47KOHM,J,0.063W	1	
R1225,26	ERJ2GEJ220	M 22 OHM, J,0.063W	2	
R1228	ERJ2GEJ220	M 22 OHM, J,0.063W	1	
R1229	ERJ2GEJ182	M 1.8KOHM, J,0.063W	1	
R1230	ERJ2GEJ220	M 22 OHM, J,0.063W	1	
R1231	ERJ2GEJ473	M 47KOHM,J,0.063W	1	
R1232,33	ERJ2GEJ332	M 3.3KOHM, J,0.063W	2	
R1234	ERJ2GE0R00	M 0.0 OHM, J,0.063W	1	
R1235,36	ERJ2GEJ272	M 2.7KOHM, J,0.063W	2	
R1238	ERJ2GEJ473	M 47KOHM,J,0.063W	1	
R1239	ERJ3EKF1202	M 12KOHM, 1/16W	1	
R1240	ERJ2GEJ473	M 47KOHM,J,0.063W	1	
R1241	ERJ2GEJ822	M 8.2KOHM, J,0.063W	1	
R1243	ERJ2GEJ102	M 1KOHM, J,0.063W	1	
R1246	ERJ2GEJ912	M 9.1KOHM, J,0.063W	1	
R1249	ERJ2GEJ473	M 47KOHM,J,0.063W	1	
R1250	ERJ2GEJ224	M 220KOHM, J,0.063W	1	
R1251,52	EXB2HV101J	RESISTOR ARRAY	2	
R1256	ERJ2GEJ102	M 1KOHM, J,0.063W	1	
R1263,64	ERJ2GEJ101	M 100 OHM, J,0.063W	2	
R1269	ERJ2GE0R00	M 0.0 OHM, J,0.063W	1	
R1270,71	ERJ2GEJ220	M 22 OHM, J,0.063W	2	
R1275	ERJ3EKF7151	M7.15KOHM, 1/16W	1	
R1279,80	ERJ2GEJ220	M 22 OHM, J,0.063W	2	
R1281	ERJ2GEJ102	M 1KOHM, J,0.063W	1	
R1282	ERJ2GEJ153	M 15KOHM ,J,0.063W	1	
R1283	ERJ2GEJ101	M 100 OHM, J,0.063W	1	
R1290	ERJ2GEJ472	M 4.7KOHM, J,0.063W	1	
R1299-02	ERJ2GE0R00	M 0.0 OHM, J,0.063W	4	
R1307	ERJ2GEJ104	M 100KOHM, J,0.063W	1	
R1308	ERJ2GEJ273	M 27KOHM ,J,0.063W	1	
R1309-12	ERJ2GEJ220	M 22 OHM, J,0.063W	4	
R1313,14	ERJ2GEJ103	M 10KOHM, J,0.063W	2	

Ref. No.	Part No.	Part Name & Description	Pcs	Remarks
R1315	ERJ2GEJ333	M 33KOHM, J,0.063W	1	
R1316	ERJ2GEJ103	M 10KOHM, J,0.063W	1	
R1318,19	ERJ2GEJ512X	M5.12KOHM, J,0.063W	2	
R1321	ERJ2GEJ153	M 15KOHM, J,0.063W	1	
R1322	ERJ2GEJ100	M 10 OHM, J,0.063W	1	
R1323,24	ERJ2GEJ823	M 82KOHM, J,0.063W	2	
R1325,26	ERJ2GEJ104	M 100KOHM, J,0.063W	2	
R1327,28	ERJ2GEJ683	M 68KOHM, J,0.063W	2	
R1329,30	ERJ2GEJ473	M 47KOHM, J,0.063W	2	
R1331,32	ERJ2GEJ104	M 100KOHM, J,0.063W	2	
R1333	ERJ2GEJ101	M 100 OHM, J,0.063W	1	
R1340	ERJ2GEJ473	M 47KOHM, J,0.063W	1	
R1344	ERJ2GEJ101	M 100 OHM, J,0.063W	1	
R1346	ERJ2GEJ473	M 47KOHM, J,0.063W	1	
R1352	ERJ2GEJ473	M 47KOHM, J,0.063W	1	
R1363	ERJ2GEJ473	M 47KOHM, J,0.063W	1	
R1367	ERJ2GEJ333	M 33KOHM, J,0.063W	1	
R1368	ERJ2GEJ183	M 18KOHM, J,0.063W	1	
R1369	ERJ2GE0R00	M 0.0 OHM, J,0.063W	1	
R1372	ERJ2GEJ473	M 47KOHM, J,0.063W	1	
R1375	ERJ2GEJ104	M 100KOHM, J,0.063W	1	
R1376	ERJ2GEJ273	M 27KOHM, J,0.063W	1	
R1377	ERJ8GEY0R00	M 0 OHM, 1/8W	1	
R1384	ERJ2GEJ101	M 100 OHM, J,0.063W	1	
R1389	ERJ2GE0R00	M 0.0 OHM, J,0.063W	1	
R1408	ERJ2GEJ104	M 100KOHM, J,0.063W	1	
R1410	ERJ2GEJ102	M 1KOHM, J,0.063W	1	
R1411	ERJ2GEJ472	M 4.7KOHM, J,0.063W	1	
R1412,13	ERJ2GEJ104	M 100KOHM, J,0.063W	2	
R1414	ERJ2GE0R00	M 0.0 OHM, J,0.063W	1	
R1426-32	ERJ8GEY0R00	M 0 OHM, 1/8W	7	
R1434	ERJ2GEJ471	M 470 OHM, J,0.063W	1	
R1436	ERJ2GEJ561	M 60 OHM, J,0.063W	1	
R1438	ERJ2GEJ680	M 68 OHM, J,0.063W	1	
R1440	ERJ2GEJ241	M 240 OHM, J,0.063W	1	
R1446	ERJ2GEJ471	M 470 OHM, J,0.063W	1	
R1448,49	ERJ2GEJ473	M 47KOHM, J,0.063W	2	
R1451,52	ERJ2GEJ473	M 47KOHM, J,0.063W	2	
R1454	ERJ2GE0R00	M 0.0 OHM, J,0.063W	1	
R1458,59	ERJ2GEJ101	M 100 OHM, J,0.063W	2	
R1461,62	ERJ2GE0R00	M 0.0 OHM, J,0.063W	2	
R1466	ERJ2GEJ103	M 10KOHM, J,0.063W	1	
R1467	ERJ2GEJ473	M 47KOHM, J,0.063W	1	
R1470	ERJ2GE0R00	M 0.0 OHM, J,0.063W	1	
R1472	ERJ2GEJ221	M 220 OHM, J,0.063W	1	
R1474	ERJ8GEY0R00	M 0 OHM, 1/8W	1	
R1478	ERJ2GEJ680	M 68 OHM, J,0.063W	1	
R1479,80	ERJ2GEJ473	M 47KOHM, J,0.063W	2	
R1490	ERJ2GE0R00	M 0.0 OHM, J,0.063W	1	
R1526	ERJ2GEJ102	M 1KOHM, J,0.063W	1	

Ref. No.	Part No.	Part Name & Description	Pcs	Remarks
R1530	ERJ2GE0R00	M 0.0 OHM, J,0.063W	1	
R1554,55	ERJ3GEY0R00	M 0 OHM, 1/16W	2	
R2005	ERJ3GEYJ104	M 100KOHM, J,1/16W	1	
R2006-11	ERJ6GEYJ223	M 22KOHM, J,1/10W	6	
R2012	ERJ3GEYJ104	M 100KOHM, J,1/16W	1	
R2013,14	ERJ3GEYJ222	M 2.2KOHM, J,1/16W	2	
R2015,16	ERJ3GEYJ331	M 330 OHM, J,1/16W	2	
R2042	ERJ3GEYJ105	M 1MOHM, J,1/16W	1	
R2043	ERJ3GEYJ473	M 47KOHM, J,1/16W	1	
R2044	ERJ3GEYJ102	M 1KOHM, J,1/16W	1	
R2045,46	ERJ3GEYJ103	M 10KOHM, J,1/16W	2	
R2048	ERJ6GEYJ471	M 470 OHM, J,1/10W	1	
R2049,50	ERJ3GEYJ103	M 10KOHM, J,1/16W	2	
R2051,52	ERJ6GEYJ184	M 180KOHM, J,1/10W	2	
R2053	ERJ6GEYJ471	M 470 OHM, J,1/10W	1	
R2054	ERJ3GEYJ103	M 10KOHM, J,1/16W	1	
R2113,14	ERJ3GEY0R00	M 0 OHM, 1/16W	2	
R2116	JOJCC0000241	CHIP INDUCTOR	1	
R2124,25	ERJ3GEYJ101	M 100 OHM, J,1/16W	2	
R2126,27	ERJ3GEYJ472	M 4.7KOHM, J,1/16W	2	
R2130	ERJ3EKF1002	M 10KOHM, 1/16W	1	
R2131	ERJ3EKF8201	M 8.2KOHM, 1/16W	1	
R2132	ERJ3GEYJ333	M 33KOHM, J,1/16W	1	
R2133	ERJ3GEY0R00	M 0 OHM, 1/16W	1	
R2137	ERJ3GEYJ333	M 33KOHM, J,1/16W	1	
R2138	ERJ3EKF1002	M 10KOHM, 1/16W	1	
R2147	ERJ3EKF1002	M 10KOHM, 1/16W	1	
R2148,49	ERJ3EKF6342	M6.34KOHM, 1/16W	2	
R2152	ERJ3GEYJ220	M 22 OHM, J,1/16W	1	
R2153	ERJ3GEYJ221	M 220 OHM, J,1/16W	1	
R2154	ERJ3GEYJ220	M 22 OHM, J,1/16W	1	
R2155,56	ERJ3GEYJ221	M 220 OHM, J,1/16W	2	
R2158	ERJ3GEYJ221	M 220 OHM, J,1/16W	1	
R2164	ERJ3GEYJ221	M 220 OHM, J,1/16W	1	
R2165,66	ERJ3GEYJ102	M 1KOHM, J,1/16W	2	
R2167	ERJ3GEYJ221	M 220 OHM, J,1/16W	1	
R2168,69	ERJ3GEYJ472	M 4.7KOHM, J,1/16W	2	
R2170-73	ERJ3GEYJ221	M 220 OHM, J,1/16W	4	
R2176,77	ERJ3GEYJ221	M 220 OHM, J,1/16W	2	
R2181	ERJ3GEY0R00	M 0 OHM, 1/16W	1	
R2182,83	ERJ3GEYJ101	M 100 OHM, J,1/16W	2	
R2184-87	ERJ3GEYJ221	M 220 OHM, J,1/16W	4	
R2188	ERJ3GEYJ103	M 10KOHM, J,1/16W	1	
R2192,93	ERJ3GEYJ221	M 220 OHM, J,1/16W	2	
R2195,96	ERJ3GEYJ104	M 100KOHM, J,1/16W	2	
R2197	ERJ3GEYJ471	M 470 OHM, J,1/16W	1	
R2202	ERJ3GEYJ101	M 100 OHM, J,1/16W	1	
R2204	ERJ6GEYJ561	M 560 OHM, J,1/10W	1	
R2208	ERJ6GEYJ471	M 470 OHM, J,1/10W	1	
R2209	ERJ3GEYJ332	M 3.3KOHM, J,1/16W	1	
R2210	ERJ6GEYJ122	M 1.2KOHM, J,1/10W	1	
R2211	ERJ3GEY0R00	M 0 OHM, 1/16W	1	
R2213	ERJ3GEYJ103	M 10KOHM, J,1/16W	1	
R2214	ERJ3GEYJ332	M 3.3KOHM, J,1/16W	1	
R2215	ERJ3GEY0R00	M 0 OHM, 1/16W	1	

Ref. No.	Part No.	Part Name & Description	Pcs	Remarks
R2224,25	ERJ3GEY0R00	M 0 OHM, 1/16W	2	
R2234-37	ERJ3GEYJ103	M 10KOHM,J,1/16W	4	
R2238,39	ERJ3GEY0R00	M 0 OHM, 1/16W	2	
R2302	ERJ3GEYJ223	M 22KOHM,J,1/16W	1	
R2303	ERJ3GEYJ562	M 5.6KOHM,J,1/16W	1	
R2304	ERJ3GEYJ104	M 100KOHM,J,1/16W	1	
R2305	ERJ3GEYJ471	M 470 OHM,J,1/16W	1	
R2306	ERJ6GEYJ821	M 820 OHM,J,1/10W	1	
R2307	ERJ3GEYJ104	M 100KOHM,J,1/16W	1	
R2310	ERJ3GEY0R00	M 0 OHM, 1/16W	1	(PA)
R2310	ERJ3GEYJ184	M 180KOHM,J,1/16W	1	(H)
R2311	ERJ3GEY0R00	M 0 OHM, 1/16W	1	(PA)
R2311	ERJ6GEYJ182	M 1.8KOHM,J,1/10W	1	(H)
R2312	ERJ3EKF1002	M 10KOHM, 1/16W	1	
R2323,24	ERJ3GEY0R00	M 0 OHM, 1/16W	2	
R2325	ERJ3GEYJ103	M 10KOHM,J,1/16W	1	
R2329	ERJ3EKF1003	M 100KOHM, 1/16W	1	
R2332	ERJ3GEYJ103	M 10KOHM,J,1/16W	1	
R2338	ERJ3GEY0R00	M 0 OHM, 1/16W	1	
R2341	ERJ6GEY0R00	M 0 OHM, 1/10W	1	
R2349	ERJ3GEYJ101	M 100 OHM,J,1/16W	1	
R2354	ERJ3GEYJ102	M 1KOHM,J,1/16W	1	
R2357	ERJ6GEY0R00	M 0 OHM, 1/10W	1	
R2359	ERJ3GEYJ222	M 2.2KOHM,J,1/16W	1	
R2360	ERJ3GEYJ103	M 10KOHM,J,1/16W	1	
R2361	ERJ3GEYJ562	M 5.6KOHM,J,1/16W	1	
R2363	ERJ3GEYJ471	M 470 OHM,J,1/16W	1	
R2364	ERJ3GEYJ473	M 47KOHM,J,1/16W	1	
R2365	ERJ3GEYJ101	M 100 OHM,J,1/16W	1	
R2366	ERJ3GEYJ472	M 4.7KOHM,J,1/16W	1	
R2368	ERJ6GEY0R00	M 0 OHM, 1/10W	1	
R2369	ERJ3GEYJ183	M 18KOHM,J,1/16W	1	
R2372,73	ERJ6GEYJ681	M 680 OHM,J,1/10W	2	
R2375	ERJ3GEYJ101	M 100 OHM,J,1/16W	1	
R2376	ERJ3EKF1002	M 10KOHM, 1/16W	1	
R2379,80	ERJ6ENF2201	M 2.2KOHM, 1/10W	2	
R2383	ERJ3EKF3301	M 3.3KOHM, 1/16W	1	
R2384	ERJ3EKF1151	M1.15KOHM, 1/16W	1	
R2387	ERJ3EKF1151	M1.15KOHM, 1/16W	1	
R2388	ERJ3EKF3301	M 3.3KOHM, 1/16W	1	(PA)
R2388,89	ERJ6GEYJ102	M 1KOHM,J,1/10W	2	(H)
R2390	ERJ3GEYJ203	M 20KOHM,J,1/16W	1	
R2391	ERJ3GEYJ103	M 10KOHM,J,1/16W	1	
R2392	ERJ3GEYJ223	M 22KOHM,J,1/16W	1	
R2393	ERJ3GEYJ103	M 10KOHM,J,1/16W	1	
R2396	ERJ3GEYJ103	M 10KOHM,J,1/16W	1	
R2397	ERJ3GEYJ473	M 47KOHM,J,1/16W	1	(H)
R2397	ERJ6GEY0R00	M 0 OHM, 1/10W	1	(PA)
R2398	ERJ3GEYJ123	M 12KOHM,J,1/16W	1	(H)
R2398	ERJ6GEY0R00	M 0 OHM, 1/10W	1	(PA)
R2399	ERJ3GEYJ102	M 1KOHM,J,1/16W	1	
R2400	ERJ6GEYJ182	M 1.8KOHM,J,1/10W	1	
R2401,02	ERJ3GEYJ331	M 330 OHM,J,1/16W	2	
R2403	ERJ3GEYJ472	M 4.7KOHM,J,1/16W	1	
R2404,05	ERJ3GEYJ331	M 330 OHM,J,1/16W	2	
R2406	ERJ3GEYJ472	M 4.7KOHM,J,1/16W	1	
R2407	ERJ3EKF1241	M1.24KOHM, 1/16W	1	
R2408	ERJ3EKF1071	M1.07KOHM, 1/16W	1	
R2409	ERJ3EKF1621	M1.62KOHM, 1/16W	1	
R2410	ERJ3EKF7870	M 787 OHM, 1/16W	1	
R2421	ERJ3EKF1621	M1.62KOHM, 1/16W	1	
R2422	ERJ3EKF7870	M 787 OHM, 1/16W	1	
R2516	ERJ6GEYJ223	M 22KOHM,J,1/10W	1	
R2517	ERJ6GEYJ470	M 47 OHM,J,1/10W	1	
R2520	ERJ6GEYJ224	M 220KOHM,J,1/10W	1	
R2524	ERJ6GEYJ223	M 22KOHM,J,1/10W	1	

Ref. No.	Part No.	Part Name & Description	Pcs	Remarks
R2525	ERJ6ENF1002	M 10KOHM, 1/10W	1	
R2526	ERJ6GEYJ562	M 5.6KOHM,J,1/10W	1	
R2529	ERJ6GEYJ562	M 5.6KOHM,J,1/10W	1	
R2530	ERJ6GEYJ223	M 22KOHM,J,1/10W	1	
R2531	ERJ6ENF4700	M 470 OHM, 1/10W	1	
R2542	ERJ6GEYJ101	M 100 OHM,J,1/10W	1	
R2545	ERJ6GEYJ101	M 100 OHM,J,1/10W	1	
R2550	ERJ6GEY0R00	M 0 OHM, 1/10W	1	
R2553	ERJ6GEYJ223	M 22KOHM,J,1/10W	1	
R2554	ERJ6GEYJ102	M 1KOHM,J,1/10W	1	
R2557	ERJ6ENF9760	M 976 OHM, 1/10W	1	
R2558	ERJ6ENF1180	M 118 OHM, 1/10W	1	
R2559,60	ERJ6GEY0R00	M 0 OHM, 1/10W	2	
R3001-10	ERJ6ENF75R0	M 75 OHM, 1/10W	10	
R3011	ERJ3GEY0R00	M 0 OHM, 1/16W	1	
R3012	ERJ6ENF75R0	M 75 OHM, 1/10W	1	
R3020	ERJ6ENF2202	M 2.2KOHM, 1/10W	1	
R3021,22	ERJ3GEYJ103	M 10KOHM,J,1/16W	2	
R3027	ERJ6ENF75R0	M 75 OHM, 1/10W	1	
R3039	ERJ3GEYJ221	M 220 OHM,J,1/16W	1	
R3044,45	ERJ3GEY0R00	M 0 OHM, 1/16W	2	
R3048	ERJ3GEYJ223	M 22KOHM,J,1/16W	1	
R3049	ERJ3GEYJ221	M 220 OHM,J,1/16W	1	
R3050	ERJ3GEYJ242	M 2.4KOHM,J,1/16W	1	
R3051	ERJ3GEYJ682	M 6.8KOHM,J,1/16W	1	
R3057,58	ERJ3GEY0R00	M 0 OHM, 1/16W	2	
R3059,60	ERJ3GEYJ221	M 220 OHM,J,1/16W	2	
R3061	ERJ3GEY0R00	M 0 OHM, 1/16W	1	
R3064	ERJ3GEYJ221	M 220 OHM,J,1/16W	1	
R3074,75	ERJ3GEYJ221	M 220 OHM,J,1/16W	2	
R3076	ERJ3GEY0R00	M 0 OHM, 1/16W	1	
R3080	ERJ3GEY0R00	M 0 OHM, 1/16W	1	
R3087	ERJ3GEYJ221	M 220 OHM,J,1/16W	1	
R3089,90	ERJ3GEYJ220	M 22 OHM,J,1/16W	2	
R3092	ERJ3GEYJ221	M 220 OHM,J,1/16W	1	
R3094,95	ERJ3GEYJ221	M 220 OHM,J,1/16W	2	
R3096	ERJ3GEY0R00	M 0 OHM, 1/16W	1	
R3097	ERJ3GEYJ221	M 220 OHM,J,1/16W	1	
R3099-01	ERJ3GEYJ221	M 220 OHM,J,1/16W	3	
R3102	ERJ3GEYJ682	M 6.8KOHM,J,1/16W	1	
R3111-14	ERJ3GEY0R00	M 0 OHM, 1/16W	4	
R3115	ERJ3GEYJ101	M 100 OHM,J,1/16W	1	
R3118	ERJ3GEYJ101	M 100 OHM,J,1/16W	1	
R3121	ERJ3EKF1300V	M 130 OHM, 1/16W	1	
R3122	ERJ3GEYJ101	M 100 OHM,J,1/16W	1	
R3123	ERJ3EKF1300V	M 130 OHM, 1/16W	1	
R3125	ERJ6GEYJ102	M 1KOHM,J,1/10W	1	
R3126	ERJ3GEYJ101	M 100 OHM,J,1/16W	1	
R3127	ERJ6GEYJ102	M 1KOHM,J,1/10W	1	
R3134	ERJ3GEYJ104	M 100KOHM,J,1/16W	1	
R3138	ERJ3EKF1000	M 100 OHM, 1/16W	1	
R3139	ERJ6GEYJ102	M 1KOHM,J,1/10W	1	
R3140	ERJ3EKF1300V	M 130 OHM, 1/16W	1	
R3141	ERJ6GEYJ102	M 1KOHM,J,1/10W	1	
R3160,61	ERJ6GEYJ102	M 1KOHM,J,1/10W	2	
R3167	ERJ3GEYJ102	M 1KOHM,J,1/16W	1	
R3174,75	ERJ3GEYJ221	M 220 OHM,J,1/16W	2	
R3206	ERJ3GEYJ101	M 100 OHM,J,1/16W	1	
R3213,14	ERJ3GEY0R00	M 0 OHM, 1/16W	2	
R3215	J0JCC0000241	CHIP INDUCTOR	1	
R3224	ERJ3GEY0R00	M 0 OHM, 1/16W	1	

Ref. No.	Part No.	Part Name & Description	Pcs	Remarks
R3227-29	ERJ3GEY0R00	M 0 OHM, 1/16W	3	
R3238	ERJ3GEY0R00	M 0 OHM, 1/16W	1	
R3239,40	ERJ3GEYJ103	M 10KOHM,J,1/16W	2	
R3250,51	ERJ3GEY0R00	M 0 OHM, 1/16W	2	
R3259	ERJ3GEYJ221	M 220 OHM,J,1/16W	1	
R3261,62	ERJ3GEY0R00	M 0 OHM, 1/16W	2	
R3277-79	ERJ3GEY0R00	M 0 OHM, 1/16W	3	
R3281	ERJ3GEY0R00	M 0 OHM, 1/16W	1	
R3283,84	ERJ3GEY0R00	M 0 OHM, 1/16W	2	
R3286	J0JCC0000241	CHIP INDUCTOR	1	
R3290,91	ERJ3GEYJ472	M 4.7KOHM,J,1/16W	2	
R3320	ERJ6GEY0R00	M 0 OHM, 1/10W	1	
R3323,24	ERJ6GEY0R00	M 0 OHM, 1/10W	2	
R3353	ERJ3EKF6802	M 68KOHM, 1/16W	1	
R3408,09	ERJ3GEYJ361	M 360 OHM,J,1/16W	2	
R3750	ERJ6ENF1432	M14.3KOHM, 1/10W	1	
R3751	ERJ6ENF6651	M6.65KOHM, 1/10W	1	
R3752	ERJ6GEY0R00	M 0 OHM, 1/10W	1	
R3753	ERJ6ENF1741	M1.74KOHM, 1/10W	1	
R3754	ERJ6ENF7151	M7.15KOHM, 1/10W	1	
R3757	ERJ6GEY0R00	M 0 OHM, 1/10W	1	
R4001	ERJ3EKF1211	M1.21KOHM, 1/16W	1	
R4004	ERJ2GE0R00	M 0.0 OHM, J,0.063W	1	
R4008	ERJ2GE0R00	M 0.0 OHM, J,0.063W	1	
R4010	ERJ2GE0R00	M 0.0 OHM, J,0.063W	1	
R4018	ERJ2GEJ103	M 10KOHM, J,0.063W	1	
R4019	ERJ2GE0R00	M 0.0 OHM, J,0.063W	1	
R4021	ERJ2GE0R00	M 0.0 OHM, J,0.063W	1	
R4022	ERJ2GEJ102	M 1KOHM, J,0.063W	1	
R4024,25	ERJ2GE0R00	M 0.0 OHM, J,0.063W	2	
R4026	ERJ2GEJ102	M 1KOHM, J,0.063W	1	
R4029	ERJ2GEJ220	M 22 OHM, J,0.063W	1	
R4031	ERJ2GEJ103	M 10KOHM, J,0.063W	1	
R4033	ERJ2GEJ103	M 10KOHM, J,0.063W	1	
R4037-39	D1HG1038A002	NETWORK RESISTER	3	
R4040,41	ERJ2GE0R00	M 0.0 OHM, J,0.063W	2	
R4045,46	ERJ3GEY0R00	M 0 OHM, 1/16W	2	
R4047	ERJ2GE0R00	M 0.0 OHM, J,0.063W	1	
R4257	ERJ3EKF3302	M 33KOHM, 1/16W	1	
R4265	ERJ3EKF3242	M32.4KOHM, 1/16W	1	
R4269	ERJ2GE0R00	M 0.0 OHM, J,0.063W	1	
R4271,72	ERJ2GE0R00	M 0.0 OHM, J,0.063W	2	
R4286,87	ERJ2GE0R00	M 0.0 OHM, J,0.063W	2	
R4293	ERJ2GE0R00	M 0.0 OHM, J,0.063W	1	
R4338-43	ERJ2GE0R00	M 0.0 OHM, J,0.063W	6	
R4457	ERJ2GE0R00	M 0.0 OHM, J,0.063W	1	
R4465	ERJ2GEJ224	M 220KOHM, J,0.063W	1	
R4469,70	ERJ3EKF1500	M 150 OHM, 1/16W	2	
R4474	ERJ3EKF1211	M1.21KOHM, 1/16W	1	
R4479,80	ERJ3EKF4220	M 422 OHM, 1/10W	2	

Ref. No.	Part No.	Part Name & Description	Pcs	Remarks
R4481	ERJ3EKF2201	M 2.2KOHM, 1/16W	1	
R4482,83	ERJ3EKF1781	M1.78KOHM, 1/16W	2	
R4486	ERJ3EKF4870	M 487 OHM, 1/16W	1	
R4487	ERJ3EKF5600	M 560 OHM, 1/16W	1	
R4488	ERJ3EKF2201	M 2.2KOHM, 1/16W	1	
R4490	ERJ6GEYJ102	M 1KOHM,J,1/10W	1	
R4492	ERJ6GEYJ102	M 1KOHM,J,1/10W	1	
R4495	ERJ3EKF4302	M 43KOHM, 1/16W	1	
R4496-99	ERJ6GEYJ102	M 1KOHM,J,1/10W	4	
R4500	ERJ3EKF2702V	M27.0KOHM, 1/16W	1	
R4501,02	ERJ6GEYJ102	M 1KOHM,J,1/10W	2	
R4503	ERJ3EKF1600	M 160 OHM, 1/16W	1	
R4507-11	ERJ2GE0R00	M 0.0 OHM, J,0.063W	5	
R4513	ERJ2GE0R00	M 0.0 OHM, J,0.063W	1	
R4517	ERJ3EKF1371	M 13.7 OHM, 1/16W	1	
R4520	ERJ3EKF1691	M1.69KOHM, 1/16W	1	
R4521,22	ERJ2GEJ220	M 22 OHM, J,0.063W	2	
R4527	ERJ2GEJ220	M 22 OHM, J,0.063W	1	
R4533	ERJ2GEJ220	M 22 OHM, J,0.063W	1	
R4540	ERJ2GE0R00	M 0.0 OHM, J,0.063W	1	
R4542	ERJ2GE0R00	M 0.0 OHM, J,0.063W	1	
R4544	ERJ2GEJ220	M 22 OHM, J,0.063W	1	
R4550	EXB28V220J	RESISTOR ARRAY	1	
R4552	EXB28V220J	RESISTOR ARRAY	1	
R4554	ERJ2GEJ220	M 22 OHM, J,0.063W	1	
R4555	EXB28V220J	RESISTOR ARRAY	1	
R4560,61	EXB28V220J	RESISTOR ARRAY	2	
R4563-65	ERJ2GEJ220	M 22 OHM, J,0.063W	3	
R4568	ERJ2GEJ101	M 100 OHM, J,0.063W	1	
R4572	ERJ2GEJ103	M 10KOHM, J,0.063W	1	
R4575	ERJ2GEJ472	M 4.7KOHM, J,0.063W	1	
R4577-79	ERJ2GEJ222	M 2.2KOHM, J,0.063W	3	
R4584	ERJ2GEJ390	M 39 OHM, J,0.063W	1	
R4597-04	ERJ2GEJ2R7X	M 2.7OHM, J,0.063W	8	
R4606	ERJ2GEJ103	M 10KOHM, J,0.063W	1	
R4607	ERJ2GEJ220	M 22 OHM, J,0.063W	1	
R4609	ERJ2GEJ103	M 10KOHM, J,0.063W	1	
R4613	ERJ2GEJ472	M 4.7KOHM, J,0.063W	1	
R4618	ERJ2GEJ472	M 4.7KOHM, J,0.063W	1	
R4621	ERJ2GEJ473	M 47KOHM,J,0.063W	1	
R4622	ERJ2GEJ560	M 56 OHM, J,0.063W	1	
R4626	ERJ2GEJ560	M 56 OHM, J,0.063W	1	
R4628	ERJ2GEJ103	M 10KOHM, J,0.063W	1	
R4629-32	ERJ2GEJ472	M 4.7KOHM, J,0.063W	4	
R4634	ERJ2GEJ220	M 22 OHM, J,0.063W	1	
R4636	ERJ2GEJ103	M 10KOHM, J,0.063W	1	
R4637	ERJ2GEJ330	M 33 OHM, J,0.063W	1	
R4639	ERJ2GEJ103	M 10KOHM, J,0.063W	1	
R4640	ERJ2GEJ220	M 22 OHM, J,0.063W	1	
R4641	EXB28V330J	RESISTOR ARRAY	1	
R4642-45	ERJ2GEJ220	M 22 OHM, J,0.063W	4	
R4647	ERJ2GEJ220	M 22 OHM, J,0.063W	1	
R4648	ERJ2GEJ330	M 33 OHM, J,0.063W	1	
R4655	ERJ2GEJ330	M 33 OHM, J,0.063W	1	
R4657	ERJ2GEJ182	M 1.8KOHM, J,0.063W	1	
R4658	ERJ2GEJ220	M 22 OHM, J,0.063W	1	
R4660	ERJ2GEJ220	M 22 OHM, J,0.063W	1	

Ref. No.	Part No.	Part Name & Description	Pcs	Remarks
R4661	ERJ2GEJ472	M 4.7KOHM, J,0.063W	1	
R4662	ERJ2GEJ220	M 22 OHM, J,0.063W	1	
R4665	EXB2HV220JV	RESISTOR ARRAY	1	
R4667	EXB2HV220JV	RESISTOR ARRAY	1	
R4668	ERJ2GEJ680	M 68 OHM, J,0.063W	1	
R4669	EXB2HV220JV	RESISTOR ARRAY	1	
R4672,73	ERJ2GEJ103	M 10KOHM, J,0.063W	2	
R4675	ERJ3EKF1802	M 18KOHM, 1/16W	1	
R4677	ERJ3EKF1802	M 18KOHM, 1/16W	1	
R4679,80	ERJ3EKF2202	M 22KOHM, 1/16W	2	
R4681,82	ERJ3EKF3302	M 33KOHM, 1/16W	2	
R4701	ERJ2GEJ680	M 68 OHM, J,0.063W	1	
R4706	ERJ2GEOR00	M 0.0 OHM, J,0.063W	1	
R4708,09	ERJ2GEJ680	M 68 OHM, J,0.063W	2	
R4710	ERJ2GEOR00	M 0.0 OHM, J,0.063W	1	
R4711	ERJ2GEJ103	M 10KOHM, J,0.063W	1	
R4712	ERJ2GEOR00	M 0.0 OHM, J,0.063W	1	
R4713,14	EXB2HV221JV	RESISTOR ARRAY	2	
R4715	ERJ2GEOR00	M 0.0 OHM, J,0.063W	1	
R4718-20	ERJ2GEJ680	M 68 OHM, J,0.063W	3	
R4727	ERJ2GEOR00	M 0.0 OHM, J,0.063W	1	
R4729,30	ERJ3EKF1000	M 100 OHM, 1/16W	2	
R4731	ERJ3EKF1001	M 1KOHM, 1/16W	1	
R4732	ERJ3EKF4751	M 4.75KOHM, 1/16W	1	
R4733	ERJ3EKF75R0	M 0.75HM, 1/16W	1	
R4734	ERJ2GEJ223	M 22KOHM, J,0.063W	1	
R4735	ERJ3EKF2001	M 2KOHM, 1/16W	1	
R4737	ERJ2GEOR00	M 0.0 OHM, J,0.063W	1	
R4738,39	ERJ2GEJ332	M 3.3KOHM, J,0.063W	2	
R4743-47	ERJ2GEJ680	M 68 OHM, J,0.063W	5	
R4749,50	EXB2HV680J	RESISTOR ARRAY	2	
R4751-54	ERJ2GEJ220	M 22 OHM, J,0.063W	4	
R4756-60	ERJ2GEJ680	M 68 OHM, J,0.063W	5	
R4762	EXB2HV680J	RESISTOR ARRAY	1	
R4763-65	ERJ2GEOR00	M 0.0 OHM, J,0.063W	3	
R4772	EXB2HV470JV	RESISTOR ARRAY	1	
R4773	ERJ2GEJ470	M 47 OHM, J,0.063W	1	
R4774	EXB2HV470JV	RESISTOR ARRAY	1	
R4775	ERJ2GEJ470	M 47 OHM, J,0.063W	1	
R4776	EXB2HV470JV	RESISTOR ARRAY	1	
R4777	ERJ2GEJ470	M 47 OHM, J,0.063W	1	
R4778	EXB2HV470JV	RESISTOR ARRAY	1	
R4779	ERJ2GEJ470	M 47 OHM, J,0.063W	1	
R4782	ERJ2GEJ220	M 22 OHM, J,0.063W	1	
R4783	ERJ2GEJ472	M 4.7KOHM, J,0.063W	1	
R4784	ERJ2GEJ220	M 22 OHM, J,0.063W	1	
R4785	ERJ2GEJ472	M 4.7KOHM, J,0.063W	1	
R4788	EXB2HV470JV	RESISTOR ARRAY	1	
R4791,92	ERJ2GEJ470	M 47 OHM, J,0.063W	2	
R4793,94	ERJ2GEJ220	M 22 OHM, J,0.063W	2	
R4796	EXB2HV470JV	RESISTOR ARRAY	1	
R4804	ERJ2GEJ101	M 100 OHM, J,0.063W	1	

Ref. No.	Part No.	Part Name & Description	Pcs	Remarks
R4805,06	ERJ3EKF1001	M 1KOHM, 1/16W	2	
R4807-11	ERJ2GEOR00	M 0.0 OHM, J,0.063W	5	
R4814	ERJ2GEJ103	M 10KOHM, J,0.063W	1	
R4816,17	ERJ2GEJ223	M 22KOHM, J,0.063W	2	
R4819	ERJ2GEJ223	M 22KOHM, J,0.063W	1	
R4822	ERJ2GEJ103	M 10KOHM, J,0.063W	1	
R4823-25	J0JAD0000025	CHIP INDUCTOR	3	
R4837	ERJ2GEJ220	M 22 OHM, J,0.063W	1	
R4838	ERJ2GEJ112	M 1.1KOHM, J,0.063W	1	
R4891	ERJ2GEOR00	M 0.0 OHM, J,0.063W	1	
R4898	ERJ2GEJ103	M 10KOHM, J,0.063W	1	
R4960	EXB2HV680J	RESISTOR ARRAY	1	
R4961-63	ERJ2GEJ680	M 68 OHM, J,0.063W	3	
R4964	EXB2HV680J	RESISTOR ARRAY	1	
R4965,66	ERJ2GEJ680	M 68 OHM, J,0.063W	2	
R4967	EXB2HV680J	RESISTOR ARRAY	1	
R4968-72	ERJ2GEJ680	M 68 OHM, J,0.063W	5	
R5601	ERJ3EKF1800	M 180 OHM, 1/16W	1	
R5603	ERJ3EKF1542	M15.4KOHM, 1/16W	1	
R5605	ERJ3GEYJ472	M 4.7KOHM,J,1/16W	1	
R5606	ERJ3GEYJ222	M 2.2KOHM,J,1/16W	1	
R5607	ERJ3EKF4531	M4.53KOHM, 1/16W	1	
R5609	ERJ3EKF2000	M 200 OHM, 1/16W	1	
R5611	ERJ6ENF8202	M 82KOHM, 1/10W	1	
R5612	ERJ6ENF1602	M 16KOHM, 1/10W	1	
R5615	ERJ3GEYJ103	M 10KOHM,J,1/16W	1	
R5617	ERJ3GEYJ102	M 1KOHM,J,1/16W	1	
R5619	ERJ3GEYJ333	M 33KOHM,J,1/16W	1	
R5620	ERJ3GEYJ102	M 1KOHM,J,1/16W	1	
R5621	ERJ3GEYJ472	M 4.7KOHM,J,1/16W	1	
R5625-27	ERJ3GEYJ472	M 4.7KOHM,J,1/16W	3	
R5632	ERJ3GEYJ471	M 470 OHM,J,1/16W	1	
R5633	ERJ3GEYJ102	M 1KOHM,J,1/16W	1	
R5634	ERJ3GEYJ471	M 470 OHM,J,1/16W	1	
R5635	ERJ3GEYJ221	M 220 OHM,J,1/16W	1	
R5637,38	ERJ3GEYJ103	M 10KOHM,J,1/16W	2	
R5639	ERJ3GEYJ222	M 2.2KOHM,J,1/16W	1	
R5640	ERJ3GEYJ472	M 4.7KOHM,J,1/16W	1	
R5641	ERJ3GEYJ222	M 2.2KOHM,J,1/16W	1	
R5642	ERJ3GEYJ471	M 470 OHM,J,1/16W	1	
R5643	ERJ3GEYJ102	M 1KOHM,J,1/16W	1	
R5644	ERJ3GEYJ222	M 2.2KOHM,J,1/16W	1	
R5645	ERJ3EKF2201	M 2.2KOHM, 1/16W	1	
R5646	ERJ3EKF4701	M 4.7KOHM, 1/16W	1	
R5647	ERJ3GEYJ221	M 220 OHM,J,1/16W	1	
R5648	ERJ3GEYJ392	M 3.9KOHM,J,1/16W	1	
R5649	ERJ3GEYJ104	M 100KOHM,J,1/16W	1	
R5650	ERJ3GEYJ221	M 220 OHM,J,1/16W	1	
R5652	ERJ3GEYOR00	M 0 OHM, 1/16W	1	
R5653,54	ERJ3GEYJ103	M 10KOHM,J,1/16W	2	
R5659	ERJ3EKF4700	M 470 OHM, 1/16W	1	
R5660	ERJ3GEYOR00	M 0 OHM, 1/16W	1	
R5662	ERJ3GEYJ472	M 4.7KOHM,J,1/16W	1	
R5664	ERJ3GEYJ472	M 4.7KOHM,J,1/16W	1	
R5665	ERJ3GEYJ473	M 47KOHM,J,1/16W	1	
R5667-69	ERJ3GEYJ473	M 47KOHM,J,1/16W	3	
R5672	ERJ3GEYJ103	M 10KOHM,J,1/16W	1	
R5676	ERJ3GEYJ103	M 10KOHM,J,1/16W	1	
R5692	ERJ3GEYJ102	M 1KOHM,J,1/16W	1	
R5693	ERJ3GEYJ333	M 33KOHM,J,1/16W	1	
R5694	ERJ3GEYJ473	M 47KOHM,J,1/16W	1	
R5695	ERJ3GEYJ103	M 10KOHM,J,1/16W	1	

Ref. No.	Part No.	Part Name & Description	Pcs	Remarks
R6001-06	ERJ14YJ150U	M 15 OHM, J,1/4W	6	
R6020	ERG2FJS101D	M 100 OHM, J, 2W	1	
R6021	ERJ14YJ150U	M 15 OHM, J,1/4W	1	
R6022	ERG2FJS101D	M 100 OHM, J, 2W	1	
R6023-27	ERJ14YJ150U	M 15 OHM, J,1/4W	5	
R6031	ERJ14YJ204	M 200KOHM, J,1/4W	1	
R6041-44	ERJ14YJ150U	M 15 OHM, J,1/4W	4	
R6051,52	ERJ14YJ150U	M 15 OHM, J,1/4W	2	
R6061,62	ERJ6GEYJ224	M 220KOHM,J,1/10W	2	
R6101-04	ERJ6GEYJ101	M 100 OHM,J,1/10W	4	
R6111,12	DOGD470JA036	M 47 OHM,J,0.25W	2	
R6113	ERJ14YJ224	M 220KOHM, J,1/4W	1	
R6131,32	ERJ6GEYJ101	M 100 OHM,J,1/10W	2	
R6133,34	ERJ6GEYJ151	M 150 OHM,J,1/10W	2	
R6135,36	DOGD100JA036	M 10 OHM,J,0.25W	2	
R6141,42	ERJ6GEYJ103	M 10KOHM,J,1/10W	2	
R6146,47	ERJ6GEYJ103	M 10KOHM,J,1/10W	2	
R6151,52	ERJ6GEYJ101	M 100 OHM,J,1/10W	2	
R6153,54	ERJ6GEYJ151	M 150 OHM,J,1/10W	2	
R6155	ERJ6GEYJ104	M 100KOHM,J,1/10W	1	
R6157,58	DOGF1R0JA047	M 1.0 OHM,J, 0.33W	2	
R6160	DOGF1R0JA047	M 1.0 OHM,J, 0.33W	1	
R6166	ERJ6GEYJ101	M 100 OHM,J,1/10W	1	
R6173	ERJ6GEYJ103	M 10KOHM,J,1/10W	1	
R6174	ERJ6GEY0R00	M 0 OHM, 1/10W	1	
R6191-94	ERJ6GEYJ101	M 100 OHM,J,1/10W	4	
R6195	DOGD104JA036	M 100KOHM,J,0.25W	1	
R6196	ERJ6GEYJ104	M 100KOHM,J,1/10W	1	
R6213	ERJ6GEYJ101	M 100 OHM,J,1/10W	1	
R6214	DOGD151JA036	M 150 OHM,J,0.25W	1	
R6215	DOGF910JA047	M 91 OHM,J, 0.33W	1	
R6216	ERJ6GEYJ102	M 1KOHM,J,1/10W	1	
R6217	DOGF910JA047	M 91 OHM,J, 0.33W	1	
R6222	ERG1FJS103D	M 10KOHM, J, 1W	1	
R6223	ERG2FJS123D	M 12KOHM, J, 2W	1	
R6225-27	ERJ6ENF1692	M16.9KOHM, 1/10W	3	
R6229	ERJ6ENF1692	M16.9KOHM, 1/10W	1	
R6232	ERJ6ENF1201	M 1.2KOHM, 1/10W	1	
R6233-35	ERJ6GEYJ273	M 27KOHM,J,1/10W	3	
R6236	ERJ6GEYJ562	M 5.6KOHM,J,1/10W	1	
R6241	EXB38V470J	RESISTOR ARRAY	1	
R6242	EXB38V472J	RESISTOR ARRAY	1	
R6243	ERJ6GEYJ470	M 47 OHM,J,1/10W	1	
R6244	ERJ6GEYJ472	M 4.7KOHM,J,1/10W	1	
R6245	ERJ6GEYJ470	M 47 OHM,J,1/10W	1	
R6246	ERJ6GEYJ472	M 4.7KOHM,J,1/10W	1	
R6251	DOGD103JA036	M 10KOHM,J,0.25W	1	
R6252,53	ERJ6ENF3902	M 39KOHM, 1/10W	2	
R6254	ERJ6ENF7501	M 7.5KOHM, 1/10W	1	
R6255,56	ERJ6GEYJ152	M 1.5KOHM,J,1/10W	2	
R6257	ERJ6GEYJ103	M 10KOHM,J,1/10W	1	
R6258	ERJ6GEYJ222	M 2.2KOHM,J,1/10W	1	
R6261	ERJ6GEYJ104	M 100KOHM,J,1/10W	1	
R6401-06	ERJ14YJ150U	M 15 OHM, J,1/4W	6	
R6421-26	ERJ14YJ150U	M 15 OHM, J,1/4W	6	

Ref. No.	Part No.	Part Name & Description	Pcs	Remarks
R6441-44	ERJ14YJ150U	M 15 OHM, J,1/4W	4	
R6451,52	ERJ14YJ150U	M 15 OHM, J,1/4W	2	
R6465	ERJ14YJ204	M 200KOHM, J,1/4W	1	
R6471	ERJ6GEYJ392	M 3.9KOHM,J,1/10W	1	
R6472	ERJ6GEYJ222	M 2.2KOHM,J,1/10W	1	
R6473	ERJ6GEYJ561	M 560 OHM,J,1/10W	1	
R6474	ERJ6GEYJ102	M 1KOHM,J,1/10W	1	
R6475,76	ERJ6GEYJ472	M 4.7KOHM,J,1/10W	2	
R6477	ERJ6GEYJ102	M 1KOHM,J,1/10W	1	
R6478	ERJ6GEYJ472	M 4.7KOHM,J,1/10W	1	
R6479	ERJ6GEYJ104	M 100KOHM,J,1/10W	1	
R6501,02	ERJ6GEYJ101	M 100 OHM,J,1/10W	2	
R6503	DOGD100JA036	M 10 OHM,J,0.25W	1	
R6504,05	ERJ6GEYJ151	M 150 OHM,J,1/10W	2	
R6506	DOGD100JA036	M 10 OHM,J,0.25W	1	
R6507,08	DOGF1R0JA047	M 1.0 OHM,J, 0.33W	2	
R6511,12	ERJ6GEYJ103	M 10KOHM,J,1/10W	2	
R6516,17	ERJ6GEYJ103	M 10KOHM,J,1/10W	2	
R6521,22	ERJ6GEYJ101	M 100 OHM,J,1/10W	2	
R6523,24	ERJ6GEYJ151	M 150 OHM,J,1/10W	2	
R6525	ERJ6GEYJ104	M 100KOHM,J,1/10W	1	
R6526	ERJ6GEYJ101	M 100 OHM,J,1/10W	1	
R6533	ERJ6GEYJ103	M 10KOHM,J,1/10W	1	
R6534	ERJ6GEY0R00	M 0 OHM, 1/10W	1	
R6561-64	EXB38V470J	RESISTOR ARRAY	4	
R6565-68	EXB38V472J	RESISTOR ARRAY	4	
R6581	DOGD103JA036	M 10KOHM,J,0.25W	1	
R6582,83	ERJ6ENF3902	M 39KOHM, 1/10W	2	
R6584	ERJ6ENF7501	M 7.5KOHM, 1/10W	1	
R6585,86	ERJ6GEYJ152	M 1.5KOHM,J,1/10W	2	
R6587	ERJ6GEYJ222	M 2.2KOHM,J,1/10W	1	
R6588	ERJ6GEYJ103	M 10KOHM,J,1/10W	1	
R6590	ERJ6GEYJ221	M 220 OHM,J,1/10W	1	
R6591	EXB38V472J	RESISTOR ARRAY	1	
R6592	ERJ6GEYJ472	M 4.7KOHM,J,1/10W	1	
R6603	ERJ6GEYJ101	M 100 OHM,J,1/10W	1	
R6604	DOGD151JA036	M 150 OHM,J,0.25W	1	
R6605	ERJ6GEYJ104	M 100KOHM,J,1/10W	1	
R6606	ERJ6ENF2741	M2.74KOHM, 1/10W	1	
R6608,09	DOGF102JA047	M 1.0 KOHM,J,0.33W	2	
R6610	ERJ6GEYJ104	M 100KOHM,J,1/10W	1	
R6611	ERJ6GEYJ105	M 1MOHM,J,1/10W	1	
R6612	ERJ6GEYJ470	M 47 OHM,J,1/10W	1	
R6613	ERJ6GEYJ105	M 1MOHM,J,1/10W	1	
R6614,15	DOGF243JA047	M 24 KOHM,J,0.33W	2	
R6616	ERJ6ENF1502	M 15KOHM, 1/10W	1	
R6617	ERJ6GEYJ105	M 1MOHM,J,1/10W	1	
R6618	ERJ6ENF1202	M 12KOHM, 1/10W	1	
R6619	ERJ6ENF1501	M 1.5KOHM, 1/10W	1	
R6620	DOD28R2JA021	M 8.2 OHM,J,5W	1	
R6621,22	ERJ6GEYJ221	M 220 OHM,J,1/10W	2	
R6642-44	ERJ6GEYJ100	M 10 OHM,J,1/10W	3	
R6646-48	ERJ6GEYJ100	M 10 OHM,J,1/10W	3	
R6658	DOD1101JA009	M 100 OHM,J,1W	1	
R6659,60	ERJ6GEYJ224	M 220KOHM,J,1/10W	2	
R6661	ERJ6GEYJ104	M 100KOHM,J,1/10W	1	
R6662	ERJ6ENF1201	M 1.2KOHM, 1/10W	1	

Ref. No.	Part No.	Part Name & Description	Pcs	Remarks
R6663	ERJ6GEYJ103	M 10KOHM,J,1/10W	1	
R6664	D0GF222JA047	M 2.2 KOHM,J,0.33W	1	
R6665	ERJ14YJ470	M 47 OHM,J, 1/2W	1	
R6666	ERJ6GEYJ104	M 100KOHM,J,1/10W	1	
R6667,68	ERJ6GEYJ472	M 4.7KOHM,J,1/10W	2	
R6671	ERJ6GEYJ470	M 47 OHM,J,1/10W	1	
R6672	ERJ6GEYJ103	M 10KOHM,J,1/10W	1	
R6673	D0GD5R6JA059	M 5.6 OHM,J,0.25W	1	
R6681,82	ERJ6GEYJ101	M 100 OHM,J,1/10W	2	
R6683	D0GD151JA036	M 150 OHM,J,0.25W	1	
R6684	ERJ6GEYJ100	M 10 OHM,J,1/10W	1	
R6685	ERJ6GEYJ471	M 470 OHM,J,1/10W	1	
R6686	ERJ6GEYJ103	M 10KOHM,J,1/10W	1	
R6687	ERJ6GEYJ222	M 2.2KOHM,J,1/10W	1	
R6688	ERJ6GEYJ472	M 4.7KOHM,J,1/10W	1	
R6689	ERJ6GEYJ100	M 10 OHM,J,1/10W	1	
R6690	ERJ6GEYJ151	M 150 OHM,J,1/10W	1	
R6691	ERJ6GEYJ103	M 10KOHM,J,1/10W	1	
R6696,97	D0D32R2JA020	M 2.2 OHM,J,5W	2	
R6700-08	ERJ6GEYJ471	M 470 OHM,J,1/10W	9	
R6710-18	ERJ6GEYJ222	M 2.2KOHM,J,1/10W	9	
R6721,22	EXB38V220J	RESISTOR ARRAY	2	
R6723	ERJ6GEYJ222	M 2.2KOHM,J,1/10W	1	
R6742	ERJ6GEYJ103	M 10KOHM,J,1/10W	1	
R6743	ERJ6GEYJ102	M 1KOHM,J,1/10W	1	
R6744	ERJ6GEYJ103	M 10KOHM,J,1/10W	1	
R6745	ERJ6GEYJ472	M 4.7KOHM,J,1/10W	1	
R6746,47	D0GD103JA036	M 10KOHM,J,0.25W	2	
R6755	ERJ6GEYJ101	M 100 OHM,J,1/10W	1	
R6756-58	D0GD101JA059	M 100 OHM,J,0.25W	3	
R6759	ERJ6GEYJ472	M 4.7KOHM,J,1/10W	1	
R6760	ERJ6GEYJ122	M 1.2KOHM,J,1/10W	1	
R6761	ERJ6GEYJ100	M 10 OHM,J,1/10W	1	
R6762	ERJ6GEYJ103	M 10KOHM,J,1/10W	1	
R6775,76	ERJ6GEYJ101	M 100 OHM,J,1/10W	2	
R6777	D0GD151JA036	M 150 OHM,J,0.25W	1	
R6781	ERJ6GEYJ470	M 47 OHM,J,1/10W	1	
R6782	ERJ6GEYJ103	M 10KOHM,J,1/10W	1	
R6791	ERJ6GEYJ102	M 1KOHM,J,1/10W	1	
R6792	ERJ6GEYJ103	M 10KOHM,J,1/10W	1	
R6793	ERJ6GEYJ101	M 100 OHM,J,1/10W	1	
R6806	ERJ6GEYJ562	M 5.6KOHM,J,1/10W	1	
R6807	ERJ6GEYJ332	M 3.3KOHM,J,1/10W	1	
R6808	ERG2FJS330D	M 33 OHM, J, 2W	1	
R6809	ERJ6GEYJ103	M 10KOHM,J,1/10W	1	
R6810,11	ERJ6GEYJ433	M 43KOHM,J,1/10W	2	
R6812	ERJ6ENF2743	M 274KOHM, 1/10W	1	
R6813	ERJ6ENF1001	M 1KOHM, 1/10W	1	
R6814	ERJ6ENF6981	M6.98KOHM, 1/10W	1	
R6815	ERJ6GEYJ222	M 2.2KOHM,J,1/10W	1	
R6816	ERJ6ENF1432	M14.3KOHM, 1/10W	1	
R6817	ERJ6ENF4701	M 4.7KOHM, 1/10W	1	
R6821	D0D2221JA021	M 220 OHM,J,2W	1	
R6822,23	ERJ12YJ104U	M 100KOHM, 1/2W	2	
R6824	ERJ6GEYJ562	M 5.6KOHM,J,1/10W	1	
R6825	ERJ6ENF2003	M 200KOHM, 1/10W	1	
R6826	ERJ6ENF2703	M 270KOHM, 1/10W	1	
R6827	ERJ6ENF1432	M14.3KOHM, 1/10W	1	
R6828	ERJ6ENF5231	M5.23KOHM, 1/10W	1	
R6829,30	ERJ6GEYJ154	M 150KOHM,J,1/10W	2	
R6831	ERJ6GEYJ103	M 10KOHM,J,1/10W	1	
R6833	ERJ6ENF5602	M 56KOHM, 1/10W	1	
R6834	ERJ6ENF5102	M 51KOHM, 1/10W	1	

Ref. No.	Part No.	Part Name & Description	Pcs	Remarks
R6835	ERJ6ENF5602	M 56KOHM, 1/10W	1	
R6836	ERJ6ENF5102	M 51KOHM, 1/10W	1	
R6837	ERJ6ENF4702	M 47KOHM, 1/10W	1	
R6839	ERJ6GEYJ472	M 4.7KOHM,J,1/10W	1	
R6841	ERJ12YJ103	M 10KOHM,J, 1/2W	1	
R6842	ERJ14YJ103	M 10KOHM, J, 1/4W	1	
R6843	ERJ6GEYJ563	M 56KOHM,J,1/10W	1	
R6844	D0D2101JA021	M 100 OHM,J,2W	1	
R6845-47	ERJ6GEYJ563	M 56KOHM,J,1/10W	3	
R6848	ERJ6GEYJ472	M 4.7KOHM,J,1/10W	1	
R6849	ERJ6ENF5902	M 59KOHM, 1/10W	1	
R6850	ERJ6ENF6202	M 62KOHM, 1/10W	1	
R6851	ERJ6ENF1501	M 1.5KOHM, 1/10W	1	
R6852	ERJ6ENF2491	M2.49KOHM, 1/10W	1	
R6853	ERJ6GEYJ101	M 100 OHM,J,1/10W	1	
R6860	D0D28R2JA021	M 8.2 OHM,J,5W	1	
R6861	ERJ6ENF3902	M 39KOHM, 1/10W	1	
R6862,63	ERJ6ENF4702	M 47KOHM, 1/10W	2	
R6864	ERJ6ENF9101	M 9.1KOHM, 1/10W	1	
R6865	ERJ6GEYJ182	M 1.8KOHM,J,1/10W	1	
R6866	ERJ6ENF1501	M 1.5KOHM, 1/10W	1	
R6867	ERJ6GEYJ392	M 3.9KOHM,J,1/10W	1	
R6868	ERJ6GEYJ223	M 22KOHM,J,1/10W	1	
R6869	ERJ6GEYJ472	M 4.7KOHM,J,1/10W	1	
R6871-73	ERJ6ENF3902	M 39KOHM, 1/10W	3	
R6874	ERJ6ENF9101	M 9.1KOHM, 1/10W	1	
R6875	ERJ6ENF3301	M 3.3KOHM, 1/10W	1	
R6876	ERJ6ENF1201	M 1.2KOHM, 1/10W	1	
R6877	ERJ6GEYJ392	M 3.9KOHM,J,1/10W	1	
R6878	ERJ6GEYJ223	M 22KOHM,J,1/10W	1	
R6879	ERJ6GEYJ472	M 4.7KOHM,J,1/10W	1	
R6886-88	ERJ6GEYJ224	M 220KOHM,J,1/10W	3	
R6901	ERJ6GEYJ101	M 100 OHM,J,1/10W	1	
R6902-04	ERJ3GEYJ220	M 22 OHM,J,1/16W	3	
R6908,09	ERJ6GEYJ221	M 220 OHM,J,1/10W	2	
R6916	ERJ6GEYJ221	M 220 OHM,J,1/10W	1	
R6921,22	ERJ6GEYJ104	M 100KOHM,J,1/10W	2	
R6923	ERJ6GEYJ472	M 4.7KOHM,J,1/10W	1	
R6931-34	ERJ6GEYJ103	M 10KOHM,J,1/10W	4	
R6935,36	ERJ8GEYJ224	M 220KOHM, J,1/8W	2	
R6951	ERJ6GEYJ101	M 100 OHM,J,1/10W	1	
R6952-54	ERJ3GEYJ220	M 22 OHM,J,1/16W	3	
R6958,59	ERJ6GEYJ221	M 220 OHM,J,1/10W	2	
R6966	ERJ6GEYJ221	M 220 OHM,J,1/10W	1	
R6981-84	ERJ6GEYJ103	M 10KOHM,J,1/10W	4	
R6985,86	ERJ8GEYJ224	M 220KOHM, J,1/8W	2	
R7111	ERJ6GEYJ102	M 1KOHM,J,1/10W	1	
R7112,13	ERJ3GEYJ220	M 22 OHM,J,1/16W	2	
R7114	ERJ3GEYJ223	M 22KOHM,J,1/16W	1	
R7115	ERJ3GEYJ104	M 100KOHM,J,1/16W	1	
R7116,17	ERJ3GEYJ220	M 22 OHM,J,1/16W	2	
R7118	ERJ6GEYJ224	M 220KOHM,J,1/10W	1	
R7120-24	EXB38V470J	RESISTOR ARRAY	5	
R7127	ERJ3GEYJ470	M 47 OHM,J,1/16W	1	
R7129-32	ERJ12YJ6R8U	M 6.8 OHM, J,1/2W	4	
R7133	ERJ3GEYJ470	M 47 OHM,J,1/16W	1	
R7136	ERJ3GEYJ470	M 47 OHM,J,1/16W	1	
R7138-41	ERJ12YJ6R8U	M 6.8 OHM, J,1/2W	4	

Ref. No.	Part No.	Part Name & Description	Pcs	Remarks
R7142	EXB38V102J	RESISTOR ARRAY	1	
R7143	ERJ3GEYJ470	M 47 OHM,J,1/16W	1	
R7146	EXB38V470J	RESISTOR ARRAY	1	
R7147-52	EXB38V102J	RESISTOR ARRAY	6	
R7154	ERJ3GEYJ470	M 47 OHM,J,1/16W	1	
R7156-59	ERJ12YJ6R8U	M 6.8 OHM, J,1/2W	4	
R7160	ERJ3GEYJ470	M 47 OHM,J,1/16W	1	
R7164,65	ERJ3GEY0R00	M 0 OHM, 1/16W	2	
R7169	EXB38V470J	RESISTOR ARRAY	1	
R7201-07	EXB38V470J	RESISTOR ARRAY	7	
R7208-10	ERJ3GEYJ470	M 47 OHM,J,1/16W	3	
R7212-15	ERJ12YJ6R8U	M 6.8 OHM, J,1/2W	4	
R7216	EXB38V470J	RESISTOR ARRAY	1	
R7217	ERJ3GEYJ470	M 47 OHM,J,1/16W	1	
R7219	ERJ6GEYJ224	M 220KOHM,J,1/10W	1	
R7221	ERJ3GEYJ470	M 47 OHM,J,1/16W	1	
R7223-26	ERJ12YJ6R8U	M 6.8 OHM, J,1/2W	4	
R7227	ERJ3GEYJ470	M 47 OHM,J,1/16W	1	
R7229	ERJ6GEY0R00	M 0 OHM, 1/10W	1	
R7231	ERJ3GEYJ470	M 47 OHM,J,1/16W	1	
R7232-35	ERJ12YJ6R8U	M 6.8 OHM, J,1/2W	4	
R7236	ERJ3GEYJ470	M 47 OHM,J,1/16W	1	
R7237-42	EXB38V102J	RESISTOR ARRAY	6	
R7245	EXB38V102J	RESISTOR ARRAY	1	
R7246-49	ERJ3GEYJ220	M 22 OHM,J,1/16W	4	
R7250,51	EXB38V470J	RESISTOR ARRAY	2	
R7255,56	ERJ3GEY0R00	M 0 OHM, 1/16W	2	
R7257	EXB38V102J	RESISTOR ARRAY	1	
R7259	ERJ3GEYJ470	M 47 OHM,J,1/16W	1	
R7261-64	ERJ12YJ6R8U	M 6.8 OHM, J,1/2W	4	
R7265	ERJ3GEYJ470	M 47 OHM,J,1/16W	1	
R7268	ERJ6GEYJ102	M 1KOHM,J,1/10W	1	
R7269	ERJ3GEYJ223	M 22KOHM,J,1/16W	1	
R7270	ERJ3GEYJ104	M 100KOHM,J,1/16W	1	
R9060-67	ERJ3GEYJ101	M 100 OHM,J,1/16W	8	
R9070	ERJ3GEYJ470	M 47 OHM,J,1/16W	1	
R9074	ERJ3GEYJ101	M 100 OHM,J,1/16W	1	
R9076	ERJ3GEYJ101	M 100 OHM,J,1/16W	1	
R9097,98	ERJ3GEYJ103	M 10KOHM,J,1/16W	2	
R9099	ERJ3GEYJ101	M 100 OHM,J,1/16W	1	
R9100,01	ERJ3GEYJ103	M 10KOHM,J,1/16W	2	
R9102	ERJ3GEYJ101	M 100 OHM,J,1/16W	1	
R9105	ERJ3GEYJ472	M 4.7KOHM,J,1/16W	1	
R9106	ERJ3GEYJ103	M 10KOHM,J,1/16W	1	
R9107	ERJ3GEYJ332	M 3.3KOHM,J,1/16W	1	
R9108,09	ERJ3GEYJ103	M 10KOHM,J,1/16W	2	
R9110	ERJ3GEYJ101	M 100 OHM,J,1/16W	1	
R9111	ERJ3GEYJ223	M 22KOHM,J,1/16W	1	
R9113	ERJ3GEYJ100	M 10 OHM,J,1/16W	1	
R9120	ERJ3GEYJ101	M 100 OHM,J,1/16W	1	
R9121	ERJ3GEYJ104	M 100KOHM,J,1/16W	1	
R9127	ERJ3GEYJ683	M 68KOHM,J,1/16W	1	
R9129	ERJ3GEYJ683	M 68KOHM,J,1/16W	1	
R9131-33	ERJ3GEYJ472	M 4.7KOHM,J,1/16W	3	
R9134	ERJ3GEYJ333	M 33KOHM,J,1/16W	1	
R9140	ERJ6GEY0R00	M 0 OHM, 1/10W	1	
R9141-45	ERJ3GEYJ101	M 100 OHM,J,1/16W	5	
R9148	ERJ3GEYJ103	M 10KOHM,J,1/16W	1	

Ref. No.	Part No.	Part Name & Description	Pcs	Remarks
R9149	ERJ3GEYJ472	M 4.7KOHM,J,1/16W	1	
R9150,51	ERJ3GEYJ220	M 22 OHM,J,1/16W	2	
R9152,53	ERJ3GEYJ472	M 4.7KOHM,J,1/16W	2	
R9154,55	ERJ3GEYJ562	M 5.6KOHM,J,1/16W	2	
R9156-59	ERJ3GEYJ103	M 10KOHM,J,1/16W	4	
R9160,61	ERJ3GEY0R00	M 0 OHM, 1/16W	2	
R9164-66	ERJ3GEYJ103	M 10KOHM,J,1/16W	3	
R9167,68	ERJ3GEYJ101	M 100 OHM,J,1/16W	2	
R9169	ERJ3GEYJ103	M 10KOHM,J,1/16W	1	
R9170-72	ERJ3GEYJ393	M 39KOHM,J,1/16W	3	
R9173-75	ERJ3GEYJ103	M 10KOHM,J,1/16W	3	
R9177	ERJ3GEYJ223	M 22KOHM,J,1/16W	1	
R9178	ERJ3GEYJ103	M 10KOHM,J,1/16W	1	
R9179	ERJ3GEYJ102	M 1KOHM,J,1/16W	1	
R9180	ERJ3GEYJ103	M 10KOHM,J,1/16W	1	
R9181-84	ERJ3GEYJ102	M 1KOHM,J,1/16W	4	
R9185,86	ERJ3GEYJ220	M 22 OHM,J,1/16W	2	
R9187,88	ERJ3GEYJ562	M 5.6KOHM,J,1/16W	2	
R9189,90	ERJ3GEYJ103	M 10KOHM,J,1/16W	2	
R9192	ERJ3GEY0R00	M 0 OHM, 1/16W	1	
R9193	ERJ3GEYJ103	M 10KOHM,J,1/16W	1	
R9194	ERJ3GEY0R00	M 0 OHM, 1/16W	1	
R9196	ERJ3GEYJ103	M 10KOHM,J,1/16W	1	
R9199	ERJ3GEYJ272	M 2.7KOHM,J,1/16W	1	
R9203	ERJ3GEYJ102	M 1KOHM,J,1/16W	1	
R9205	ERJ3GEYJ472	M 4.7KOHM,J,1/16W	1	
R9206,07	ERJ3GEYJ102	M 1KOHM,J,1/16W	2	
R9215	ERJ3GEYJ123	M 12KOHM,J,1/16W	1	
R9217-22	ERJ3GEYJ103	M 10KOHM,J,1/16W	6	
R9223	ERJ3GEYJ472	M 4.7KOHM,J,1/16W	1	
R9225	ERJ3GEYJ472	M 4.7KOHM,J,1/16W	1	
R9236	ERJ3GEY0R00	M 0 OHM, 1/16W	1	
R9237	ERJ3GEYJ103	M 10KOHM,J,1/16W	1	
R9240	ERJ3GEY0R00	M 0 OHM, 1/16W	1	
R9317	ERJ3GEYJ391	M 390 OHM,J,1/16W	1	
R9348	D1HG8208A002	NETWORK RESISTER	1	
R9349	EXB38V820J	RESISTOR ARRAY	1	
R9350,51	ERJ3GEYJ220	M 22 OHM,J,1/16W	2	
R9352	EXB38V820J	RESISTOR ARRAY	1	
R9353,54	D1HG8208A002	NETWORK RESISTER	2	
R9355,56	ERJ3GEYJ472	M 4.7KOHM,J,1/16W	2	
R9357-59	D1HG8208A002	NETWORK RESISTER	3	
R9360	EXB38V820J	RESISTOR ARRAY	1	
R9361,62	ERJ3GEYJ220	M 22 OHM,J,1/16W	2	
R9363	EXB2HV470JV	RESISTOR ARRAY	1	
R9366	ERJ3GEYJ472	M 4.7KOHM,J,1/16W	1	
R9367	ERJ3GEYJ103	M 10KOHM,J,1/16W	1	
R9368	ERJ3GEYJ104	M 100KOHM,J,1/16W	1	
R9369	ERJ3GEYJ472	M 4.7KOHM,J,1/16W	1	
R9370	ERJ3GEYJ103	M 10KOHM,J,1/16W	1	
R9371	ERJ3GEYJ104	M 100KOHM,J,1/16W	1	
R9379	ERJ3GEY0R00	M 0 OHM, 1/16W	1	
R9380	ERJ3GEYJ560	M 56 OHM,J,1/16W	1	
R9382	ERJ3GEYJ103	M 10KOHM,J,1/16W	1	
R9390	ERJ3GEYJ101	M 100 OHM,J,1/16W	1	
R9391	ERJ3GEYJ104	M 100KOHM,J,1/16W	1	
R9394	ERJ3GEY0R00	M 0 OHM, 1/16W	1	

Ref. No.	Part No.	Part Name & Description	Pcs	Remarks
R9395	ERJ3GEYJ220	M 22 OHM,J,1/16W	1	
R9501,02	ERJ3GEYJ103	M 10KOHM,J,1/16W	2	
R9503	ERJ3GEYJ470	M 47 OHM,J,1/16W	1	
R9506	ERJ3GEYJ220	M 22 OHM,J,1/16W	1	
R9507	ERJ3GEY0R00	M 0 OHM, 1/16W	1	
R9511-13	ERJ3GEYJ470	M 47 OHM,J,1/16W	3	
R9516	ERJ3GEYJ103	M 10KOHM,J,1/16W	1	
R9518	ERJ3GEYJ561	M 560 OHM,J,1/16W	1	
R9523	ERJ3GEYJ103	M 10KOHM,J,1/16W	1	
R9525	ERJ3GEYJ103	M 10KOHM,J,1/16W	1	
R9526	ERJ3GEY0R00	M 0 OHM, 1/16W	1	
R9527,28	EXB2HV272JV	RESISTOR ARRAY	2	
R9529,30	ERJ3GEYJ103	M 10KOHM,J,1/16W	2	
R9531-33	ERJ3GEYJ470	M 47 OHM,J,1/16W	3	
R9534	EXB38V470J	RESISTOR ARRAY	1	
R9535,36	ERJ3GEYJ470	M 47 OHM,J,1/16W	2	
R9537	ERJ3GEYJ103	M 10KOHM,J,1/16W	1	
R9540	ERJ3GEYJ103	M 10KOHM,J,1/16W	1	
R9543,44	ERJ3GEYJ103	M 10KOHM,J,1/16W	2	
R9545	ERJ3GEYJ304V	M 300KOHM,J,1/16W	1	
R9548-50	ERJ3GEYJ103	M 10KOHM,J,1/16W	3	
R9552	ERJ3GEYJ103	M 10KOHM,J,1/16W	1	
R9555	ERJ3GEY0R00	M 0 OHM, 1/16W	1	
R9800	ERJ3EKF1302	M 23KOHM, 1/16W	1	
R9801	ERJ3EKF2402	M 24KOHM, 1/16W	1	
R9802	ERJ3EKF6202	M 62KOHM, 1/16W	1	
R9803	ERJ3GEY0R00	M 0 OHM, 1/16W	1	
R9804	ERJ3EKF2402	M 24KOHM, 1/16W	1	
R9805	ERJ3EKF3002	M 30KOHM, 1/16W	1	
R9806	ERJ3EKF3902	M 39KOHM, 1/16W	1	
R9807	ERJ3GEY0R00	M 0 OHM, 1/16W	1	
R9808	ERJ3GEYJ104	M 100KOHM,J,1/16W	1	
R9810	ERJ3EKF3001	M 3KOHM, 1/16W	1	
R9813	ERJ3EKF2401	M 2.4KOHM, 1/16W	1	
R9814	ERJ3EKF6802	M 68KOHM, 1/16W	1	
R9815	ERJ3EKF2202	M 22KOHM, 1/16W	1	
R9816	ERJ3EKF8202	M 82KOHM, 1/16W	1	
R9821	ERJ3GEYJ103	M 10KOHM,J,1/16W	1	
R9823-27	ERJ3GEYJ101	M 100 OHM,J,1/16W	5	
R9828	ERJ3GEYJ104	M 100KOHM,J,1/16W	1	
R9830,31	ERJ3GEYJ103	M 10KOHM,J,1/16W	2	
R9838,39	ERJ3GEYJ101	M 100 OHM,J,1/16W	2	
R9840	ERJ3GEYJ220	M 22 OHM,J,1/16W	1	
R9841	ERJ3GEY0R00	M 0 OHM, 1/16W	1	
R9842-44	ERJ3GEYJ101	M 100 OHM,J,1/16W	3	
R9845	ERJ3GEYJ562	M 5.6KOHM,J,1/16W	1	
R9846,47	EXB2HV272JV	RESISTOR ARRAY	2	
R9848,49	EXB2HV470JV	RESISTOR ARRAY	2	
R9850	ERJ3GEYJ473	M 47KOHM,J,1/16W	1	
R9854	ERJ3GEYJ101	M 100 OHM,J,1/16W	1	
R9859	EXB38V101J	RESISTOR ARRAY	1	
R9861-63	ERJ3GEYJ103	M 10KOHM,J,1/16W	3	
R9868	ERJ3GEYJ104	M 100KOHM,J,1/16W	1	
R9869-71	ERJ3GEYJ103	M 10KOHM,J,1/16W	3	
R9872	ERJ3GEY0R00	M 0 OHM, 1/16W	1	
R9878	ERJ3EKF3902	M 39KOHM, 1/16W	1	
R9879	ERJ3EKF2002	M 20KOHM, 1/16W	1	
R9880	ERJ3EKF3602	M 36KOHM, 1/16W	1	
R9883	ERJ3GEY0R00	M 0 OHM, 1/16W	1	
R9884	ERJ3GEYJ104	M 100KOHM,J,1/16W	1	

Ref. No.	Part No.	Part Name & Description	Pcs	Remarks
R9891	ERJ3EKF4702	M 47KOHM, 1/16W	1	
R9892	ERJ3EKF1502	M 15KOHM, 1/16W	1	
R9893	ERJ3EKF3602	M 36KOHM, 1/16W	1	
R9896	ERJ3GEY0R00	M 0 OHM, 1/16W	1	
R9897	ERJ3GEYJ104	M 100KOHM,J,1/16W	1	
R9903	EXB2HV470JV	RESISTOR ARRAY	1	
R9904	ERJ3GEYJ470	M 47 OHM,J,1/16W	1	
R9905	ERJ3GEYJ330	M 33 OHM,J,1/16W	1	
R9906	EXB38V470J	RESISTOR ARRAY	1	
R9907	ERJ3GEYJ151	M 150 OHM,J,1/16W	1	
R9917,18	ERJ3GEY0R00	M 0 OHM, 1/16W	2	
R9919,20	ERJ3GEYJ103	M 10KOHM,J,1/16W	2	
R9922	ERJ3GEY0R00	M 0 OHM, 1/16W	1	
R9929	ERJ3GEY0R00	M 0 OHM, 1/16W	1	
R9936-39	ERJ3EKF1001	M 1KOHM, 1/16W	4	
R9940	ERJ3GEYJ330	M 33 OHM,J,1/16W	1	
R9941,42	ERJ3GEYJ470	M 47 OHM,J,1/16W	2	
R9943-51	EXB38V470J	RESISTOR ARRAY	9	
R9952-55	ERJ3GEYJ470	M 47 OHM,J,1/16W	4	
R9956	ERJ3GEYJ103	M 10KOHM,J,1/16W	1	
RM2510	PNA4701M05TV	REMOCO RECEIVER	1	
RTL	TNPA3756CY	CIRCUIT BOARD DG	1	△
RTL	TNPA3760AC	CIRCUIT BOARD H	1	△
RTL	TNPA3851	CIRCUIT BOARD TU	1	△
RTL	TNPA3852	CIRCUIT BOARD HC	1	△
RTL	TNPA3761AH	CIRCUIT BOARD PA	1	△
RTL	TNPA3799AB	CIRCUIT BOARD C1	1	△
RTL	TNPA3800AB	CIRCUIT BOARD C2	1	△
RTL	TZTNP01BMTB	CIRCUIT BOARD D	1	△
RTL	TNPA3911AG	CIRCUIT BOARD P	1	△
RTL	TNPA3794AB	CIRCUIT BOARD SC	1	△
RTL	TNPA3875AB	CIRCUIT BOARD SD	1	△
RTL	TNPA3795AB	CIRCUIT BOARD SS	1	△
RTL	TNPA3874AB	CIRCUIT BOARD SU	1	△
RTL	TNPA3603AH	CIRCUIT BOARD K	1	△
RTL	TNPA3604AD	CIRCUIT BOARD S	1	△
S1	K1KA03AA0193	3P CONNECTOR	1	
SC2	K1KA02A00626	2P CONNECTOR	1	
SC20	K1KA20AA0008	20P CONNECTOR	1	
SC23	K1KA03AA0193	3P CONNECTOR	1	
SC30	K1KA08AA0192	8P CONNECTOR	1	
SC41,42	K1ML80B00001	80P CONNECTOR	2	
SC45,46	K1KA09A00239	9P CONNECTOR	2	
SD1-D3	K1MN80B00012	80P CONNECTOR	3	
SD46	K1KB09A00045	9P CONNECTOR	1	
SS11	K1KA02A00626	2P CONNECTOR	1	
SS12	K1KA10AA0194	10P CONNECTOR	1	
SS23	K1KA12AA0194	12P CONNECTOR	1	
SS34	K1KA03AA0193	3P CONNECTOR	1	
SS41-44	K1MN13B00020	13P CONNECTOR	4	
SSMM1	TMME260	CLAMPER	1	
SU1-U3	K1MN80B00012	80P CONNECTOR	3	
SU45	K1KB09A00045	9P CONNECTOR	1	
SW2500	K0F162B00002	SWITCH	1	
SW3751-55	EVQ11G05R	SWITCH	5	
T6602	ETS22AE2G9AD	SWITCHING TRANS	1	

Ref. No.	Part No.	Part Name & Description	Pcs	Remarks
TU001	ENG36A50GF		1	△
TU5,U6	K1KB15B00013	15P CONNECTOR	2	
VR6000	EVMEASA00B14	CONTROL 10KOHMB 0.3W	1	
VR6600	EVMEASA00B23	CONTROL 2KOHMB 0.3W	1	
VR6602	EVMEASA00B14	CONTROL 10KOHMB 0.3W	1	
X1100	H0J100500030	CRYSTAL	1	
X1101	H0J327200114	CRYSTAL	1	
X2101	H0J184500027	CRYSTAL	1	
X4004	H0J270500087	CRYSTAL	1	
X9000	H2D200500011	CRYSTAL	1	
X9200	H0J200500038	CRYSTAL	1	
ZA2101-08	TESA169	SHIELD CLIP	8	
ZA2300,01	K4CZ01000027	COMPATIBLE WITH JALCO K9	2	
ZA3401-03	K4CZ01000027	COMPATIBLE WITH JALCO K9	3	
ZA3405	K4CZ01000027	COMPATIBLE WITH JALCO K9	1	
ZA4001,02	K4CD08000002	TERMINAL	2	
ZA6001-03	K4CD01000011	TERMINAL	3	
ZA6401-03	K4CD01000011	TERMINAL	3	
ZA7101-03	K4CD01000013	TERMINAL	3	
ZA7201-04	K4CD01000013	TERMINAL	4	
ZA9001	K4CD01000011	TERMINAL	1	
C402	FLJ1C1050011	C 1UF, Z, 50V	1	
C404	FOCAF105A021	C 1UF, 250V	1	△
C407	EEUEB2W220B	E 22UF, 450V	1	△
C408	ECJ2XB1H102K	C 1000PF, K, 50V	1	
C409	FOCAF225A021	C 22UF, 250V	1	△
C410	ECJ2XB1H103K	C 0.01UF, K, 50V	1	
C413	ECJ2XB1H104K	C 0.1UF, K, 50V	1	
C414	ECQU2A473ML	P 0.047UF, M,250V	1	△
C421	FLJ1C1050011	C 1UF, Z, 50V	1	
C422	ECJ2XB1H103K	C 0.01UF, K, 50V	1	
C423	ECJ2XB1H472K	C 4700PF, K, 50V	1	
C425	ECJ2XB1H103K	C 0.01UF, K, 50V	1	
C426	ECJ2XC1H471J	C 470PF, J, 50V	1	
C427	FLJ1C1050011	C 1UF, Z, 50V	1	
C428	ECJ2XC1H221J	C 220PF, J, 50V	1	
C429	F1E2J4730001	C 0.047PF, , 600V	1	
C431	ECJ2XB1H102K	C 1000PF, K, 50V	1	
C432	FLJ1C1050011	C 1UF, Z, 50V	1	
C433	ECJ3XB1E104K	C 0.1UF, K, 25V	1	
C434	FLJ1C1050011	C 1UF, Z, 50V	1	
C436	FLJ1C1050011	C 1UF, Z, 50V	1	
C440	ECA1HM100	E 10UF, 50V	1	
C443,44	F1A3A102A040	C 1000PF, J, 1KV	2	
C445	FLJ1C1050011	C 1UF, Z, 50V	1	
C446	F2B2W3910005	C 390UF, 450V	1	△
C450	ECJ2XB1H103K	C 0.01UF, K, 50V	1	
C451	F1A3A101A040	C 100PF, J, 1KV	1	
C457	ECWH12333RHV	P 0.013UF,J,1.2KV	1	
C460,61	F1A3A331A039	E 330UF, 1KV	2	
C462	ECJ3YB1E105K	C 1UF, K, 25V	1	
C463	ECJ2XC1H220J	C 22UF, J, 50V	1	
C467	ECKCNA221KB7	C 220PF, M,	1	△
C468	ECJ2XB1H103K	C 0.01UF, K, 50V	1	
C469	ECKCNA221KB7	C 220PF, M,	1	△
C470	FOCAF105A021	C 1UF, 250V	1	△
C473,74	ECKCNA101KB7	C 100PF	2	△
C476	ECKCNA101KB7	C 100PF	1	△
C478	ECKCNA101KB7	C 100PF	1	△

Ref. No.	Part No.	Part Name & Description	Pcs	Remarks
C493	ECA1HM470	E 47UF, 50V	1	
C494	F2A2E1R00008	E 1.0UF, 250V	1	
C497	ECA1HM470	E 47UF, 50V	1	
C501,02	ECJ2XB1H103K	C 0.01UF, K, 50V	2	
C503	ECJ2XC1H471J	C 470PF, J, 50V	1	
C504	FLJ1C1050011	C 1UF, Z, 50V	1	
C505	ECJ2XB1H102K	C 1000PF, K, 50V	1	
C506,07	ECJ2XB1H103K	C 0.01UF, K, 50V	2	
C508	ECJ2XC1H471J	C 470PF, J, 50V	1	
C509	ECA1EHG101	E 100UF, 25V	1	
C510	ECJ2XB1H104K	C 0.1UF, K, 50V	1	
C511	ECJ2XB1H102K	C 1000PF, K, 50V	1	
C512-14	ECJ2XC1H471J	C 470PF, J, 50V	3	
C515	F2A1A1220011	E 1200UF, 10V	1	
C516	ECJ2XB1C474K	C 0.47UF, Z, 16V	1	
C517	F2A1E221A096	E 220UF, 25V	1	
C518	ECJ2XB1H104K	C 0.1UF, K, 50V	1	
C519	FLJ1C1050011	C 1UF, Z, 50V	1	
C523	ECJ3YB1E105K	C 1UF, K, 25V	1	
C526	ECJ2XB1H223K	C 0.022UF, K, 50V	1	
C527	ECJ3YB1E475K	C 4.7UF, K, 25V	1	
C528,29	FLJ1C1050011	C 1UF, Z, 50V	2	
C530	ECJ2VB1H333K	C 0.033UF, K, 50V	1	
C531	ECJ3YB1E105K	C 1UF, K, 25V	1	
C533	ECJ2XB1H103K	C 0.01UF, K, 50V	1	
C534	ECJ2XC1H471J	C 470PF, J, 50V	1	
C546,47	ECJ2XB1H102K	C 1000PF, K, 50V	2	
C550	ECJ2XC1H331J	C 330PF, J, 50V	1	
C551,52	ECJ2XB1H104K	C 0.1UF, K, 50V	2	
C554	FLJ1C1050011	C 1UF, Z, 50V	1	
C555	F2A2C101A120	E 1000UF, 160V	1	△
C556,57	EEUFC1E152	E 1500UF, 25V	2	
C558	F2A1E4710065	E 470UF, 25V	1	
C559	F2A1A1220011	E 1200UF, 10V	1	
C562	ECJ2XB1H223K	C 0.022UF, K, 50V	1	
C571	ECJ2XC1H330J	C 33PF, J, 50V	1	
C574	ECJ2XB1H104K	C 0.1UF, K, 50V	1	
C577	F2A2A330A022	E 33UF, 100V	1	△
C581	ECJ2XB1H223K	C 0.022UF, K, 50V	1	
C583	ECJ2XB1H102K	C 1000PF, K, 50V	1	
C584,85	ECJ2XB1H223K	C 0.022UF, K, 50V	2	
C587	ECJ2XB1H332K	C 3300PF, K, 50V	1	
C601	ECJ2XB1H103K	C 0.01UF, K, 50V	1	
C603	ECJ2FB1E105K	C 1UF, K, 25V	1	
C604,05	F2A2D1510008	E 150UF, 200V	2	△
C607	FLJ1C1050011	C 1UF, Z, 50V	1	
C608	ECJ2XB1H103K	C 0.01UF, K, 50V	1	
C610	FLJ1C1050011	C 1UF, Z, 50V	1	
C611	F2B2D1720005	E 1700UF,@ 200V	1	△
C612,13	ECJ2XB1H103K	C 0.01UF, K, 50V	2	
C615	F2B2D1720005	E 1700UF,@ 200V	1	△
C616	F1A3A102A040	C 1000PF, J, 1KV	1	
C619	ECJ2XB1H104K	C 0.1UF, K, 50V	1	
C620	ECJ2XB1H103K	C 0.01UF, K, 50V	1	
C623	ECA1HM100	E 10UF, 50V	1	
C624	ECJ2XB1H103K	C 0.01UF, K, 50V	1	
C625	ECA1HM100	E 10UF, 50V	1	
C626	ECJ2XB1H103K	C 0.01UF, K, 50V	1	
C627	ECJ2XB1H102K	C 1000PF, K, 50V	1	
C629-31	ECJ2XB1H103K	C 0.01UF, K, 50V	3	
C632	ECJ2XC1H331J	C 330PF, J, 50V	1	
C634	ECJ2XB1H102K	C 1000PF, K, 50V	1	
C635	ECJ2XB1H103K	C 0.01UF, K, 50V	1	
C638,39	ECJ2XB1H103K	C 0.01UF, K, 50V	2	
C640	ECJ2XB1H104K	C 0.1UF, K, 50V	1	
C641	ECJ2XB1H102K	C 1000PF, K, 50V	1	
C643	ECA1HM470	E 47UF, 50V	1	
C650	ECJ2XB1H104K	C 0.1UF, K, 50V	1	
C653	ECJ2XB1H102K	C 1000PF, K, 50V	1	
C654	ECJ3YB1E105K	C 1UF, K, 25V	1	
C655,56	ECJ3YB1E225K	C 2.2UF, K, 25V	2	
C657	ECJ2XB1H102K	C 1000PF, K, 50V	1	
C658	ECJ3YB1E105K	C 1UF, K, 25V	1	

Ref. No.	Part No.	Part Name & Description	Pcs	Remarks
C659	ECJ2XB1H103K	C 0.01UF, K, 50V	1	
C660	ECJ2FB1C225K	C 22UF, K, 16V	1	
C661,62	ECJ2XB1H103K	C 0.01UF, K, 50V	2	
D401	B0FBAT000006	DIODE	1	△
D404	B0EBKT000007	DIODE	1	△
D407	MA111	DIODE	1	
D411	B0BB17000009	DIODE	1	
D412	B0HAMM000122	DIODE	1	
D415	B0JAME000099	DIODE	1	
D416	B0HAMP000067	DIODE	1	
D417	B0HAPR000013	DIODE	1	
D418	B0BC8R100013	DIODE	1	
D419,20	B0HAPR000013	DIODE	2	
D423	MA188	DIODE	1	
D425	MA188	DIODE	1	
D429	ERA15-10	DIODE	1	
D430	MA111	DIODE	1	
D431,32	B0JCDD000002	DIODE	2	
D433	B0BC01400033	DIODE	1	
D435	ERA15-10	DIODE	1	
D436-38	MA4200M	ZENER DIODE	3	
D441	B0HAMM000122	DIODE	1	
D444	B0HAMM000122	DIODE	1	
D445	MA4360H	ZENER DIODE	1	
D501	B0HAPR000012	DIODE	1	
D503,04	MA165	DIODE	2	
D505	B0JAME000099	DIODE	1	
D506	MAZ80470LL	ZENER DIODE	1	
D507,08	B0BC7R400023	DIODE	2	
D509	B0JANG000018	DIODE	1	
D511	B0JAML000011	DIODE	1	
D512,13	MA111	DIODE	2	
D514	B0BC6R100025	DIODE	1	
D515	B0BC3R200008	DIODE	1	
D516-18	MA4330M	ZENER DIODE	3	
D520	MA111	DIODE	1	
D521	B0JAME000099	DIODE	1	
D528,29	MA153	DIODE	2	
D530	B0BC9R900013	DIODE	1	
D531	B0HBSN000013	DIODE	1	
D535	MA188	DIODE	1	
D536	B0JBSG000026	DIODE	1	
D538	B0BC5R100039	DIODE	1	
D539,40	B0AARR000010	DIODE	2	
D542	MA4200M	ZENER DIODE	1	
D543	B0BC01400033	DIODE	1	
D544,45	MA4200M	ZENER DIODE	2	
D549	B0BC02500008	DIODE	1	
D551	B0BC01300033	DIODE	1	
D555	B0BC7R400023	DIODE	1	
D559	B0BC7R400023	DIODE	1	
D563	B0BC6R100025	DIODE	1	
D569-72	B0BC02500008	DIODE	4	
D574	MA165	DIODE	1	
D575	MA188	DIODE	1	
D579	MA165	DIODE	1	
D582	MAZ705600F	ZENER DIODE	1	
D585	B0BC7R400023	DIODE	1	
D586	B0HAMP000067	DIODE	1	
D587	MA188	DIODE	1	
D588	B0BC3R200008	DIODE	1	
D590	B0BC3R200008	DIODE	1	
D596	ERA15-10	DIODE	1	
D598	B0BC5R100039	DIODE	1	
D599	B0JCND000009	DIODE	1	
D600	B0BC7R400023	DIODE	1	
D601	B0BC5R100039	DIODE	1	
D602	B0BC8R100013	DIODE	1	
F410	K5G102B00020	FUSE	1	△
IC401	CNC1S171R	IC	1	△

Ref. No.	Part No.	Part Name & Description	Pcs	Remarks
IC402	C0DAEMB00004	IC	1	
IC403-05	CNC1S171R	IC	3	△
IC406	C0DAZZZ00021	IC	1	
IC408	CNC1S171R	IC	1	△
IC409	MIP2G40MPSCF	IC	1	△
IC410	CNC1S171R	IC	1	△
IC411	C0DAEMB00004	IC	1	
IC412	CNC1S171R	IC	1	△
IC501	C2ABDB000110	IC	1	
IC502	C0EBH0000210	IC	1	
IC504	C0DAEMB00004	IC	1	
IC505	CNC1S171R	IC	1	
IC506	C0ZBZ0000878	IC	1	
IC507	CNC1S171R	IC	1	
IC509	C0DABZZ00010	IC	1	
IC510	C0DBAZG00034	IC	1	
IC512	C0DAEMB00004	IC	1	
IC520	LSSK0062	IC	1	
L403	EXCELSA35	BEAD CHOKE	1	
L404,05	G0B123K00004	CHOKE COIL	2	△
L410	ELF17N004A	LINE FILTER	1	△
L510	EXCELDLDR25C	BEAD CHOKE	1	
L511	G0A470ZA0033	CHOKE COIL	1	
L512	ELESE4R7JA	PEAKING COIL	1	
L513	EXCELDLDR25C	BEAD CHOKE	1	
P2	K1KA02A00626	2P CONNECTOR	1	
P5	K1KA11AA0194	11P CONNECTOR	1	
P9	K1KA03A00537	3P CONNECTOR	1	
P10	K1KA06A00452	6P CONNECTOR	1	
P11	K1KA02A00626	2P CONNECTOR	1	
P12	K1KA10AA0194	10P CONNECTOR	1	
P23	K1KA03AA0193	3P CONNECTOR	1	
P25	K1KA20AA0178	20P CONNECTOR	1	
PMM1	TMM7464-2	CLAMPER	1	
PMM2,M3	TMME088	CLAMPER	2	
PMM4-M6	TMM7464-2	CLAMPER	3	
PMM7	TMME047	CLAMPER	1	
PR401	K5Y502BA0001	FUSE	1	△
PR505	K5H5022A0023	FUSE	1	△
PR509	ERBSE0R50U	FUSE	1	△
PR601	K5G312B00012	FUSE	1	△
Q401	B1CHND000004	TRANSISTOR	1	
Q402	B1DFDD000019	TRANSISTOR	1	
Q404	B1BCCF000022	TRANSISTOR	1	
Q406	B1DEHQ000007	TRANSISTOR	1	△
Q407	B1HFCFA00021	TRANSISTOR	1	
Q408,09	B1DHCD000034	TRANSISTOR	2	
Q412,13	B1DEGQ000070	TRANSISTOR	2	△
Q418	2SD1819A	TRANSISTOR	1	
Q420-22	2SD1819A	TRANSISTOR	3	
Q434	B1CEJQ000003	TRANSISTOR	1	
Q501,02	2SD1820A	TRANSISTOR	2	
Q505	B1CEJQ000002	TRANSISTOR	1	
Q507	B1DAGQ000013	TRANSISTOR	1	
Q508	B1HBCFA00033	TRANSISTOR	1	
Q509	B1HDCEA00001	TRANSISTOR	1	
Q510	B1DHBD000005	TRANSISTOR	1	
Q512	B1CBGD000001	FET	1	
Q517	B1HBCFA00033	TRANSISTOR	1	
Q520	B1HBCFA00033	TRANSISTOR	1	
Q521	B1CBGD000001	FET	1	
Q524	B1CFGF000008	TRANSISTOR	1	
Q525	B1CBGD000001	FET	1	
Q527	B1CERL000005	TRANSISTOR	1	
Q530	2SD1819A	TRANSISTOR	1	
Q535	2SD1819A	TRANSISTOR	1	
Q537	B1DFDD000019	TRANSISTOR	1	

Ref. No.	Part No.	Part Name & Description	Pcs	Remarks
Q538	B1CBGD000001	FET	1	
Q540	B1DHCD000034	TRANSISTOR	1	
Q541	B1CBGD000001	FET	1	
Q551	B1CBGD000001	FET	1	
Q553	2SD1819A	TRANSISTOR	1	
Q554	B1DHCD000034	TRANSISTOR	1	
Q555,56	B1DFGD000045	TRANSISTOR	2	
Q557-59	2SD1819A	TRANSISTOR	3	
Q561	2SD1819A	TRANSISTOR	1	
Q563	B1CFGF000008	TRANSISTOR	1	
Q564,65	2SB1218ARL	TRANSISTOR	2	
Q566	2SD1819A	TRANSISTOR	1	
Q568	B1CHGD000006	TRANSISTOR	1	
Q569	B1CBGD000001	FET	1	
R401	ERJ6GEYJ103	M 10KOHM,J,1/10W	1	
R402	ERJ6GEYJ821	M 820 OHM,J,1/10W	1	
R403	ERJ6GEYJ105	M 1MOHM,J,1/10W	1	
R404	ERJ6GEYJ102	M 1KOHM,J,1/10W	1	
R406	ERX12SJ2R2V	M 2.2 OHM,J,1/2W	1	
R407	ERJ8ENF4303	M 43KOHM, 1/8W	1	
R410	D1F5100E0003	CHIP RESISTOR	1	△
R412	ERJ6GEY0R00	M 0 OHM, J,1/10W	1	
R413	D1F5100E0003	CHIP RESISTOR	1	△
R414	ERJ8GEYJ153	M 15KOHM, J,1/8W	1	
R415	ERJ6GEYJ103	M 10KOHM,J,1/10W	1	
R416	ERJ6GEYJ305	M 3MOHM,J,1/10W	1	
R417	ERJ6ENF4303	M 430KOHM, 1/10W	1	
R418	ERJ6GEYJ220	M 22 OHM,J,1/10W	1	
R419	ERJ6GEYJ104	M 100KOHM,J,1/10W	1	
R420	ERJ6GEY0R00	M 0 OHM, 1/10W	1	
R421	ERJ6GEYJ333	M 33KOHM,J,1/10W	1	
R422	ERJ6GEYJ334	M 330KOHM,J,1/10W	1	
R423	ERJ6GEYJ102	M 1KOHM,J,1/10W	1	
R424	ERJ6GEYJ223	M 22KOHM,J,1/10W	1	
R425	ERJ6ENF3902	M 39KOHM, 1/10W	1	
R426	ERJ6GEYJ103	M 10KOHM,J,1/10W	1	
R427	ERJ8ENF4303	M 43KOHM, 1/8W	1	
R428	ERJ6GEYJ103	M 10KOHM,J,1/10W	1	
R429	ERJ6GEYJ4R7	M 4.7 OHM,J,1/10W	1	
R430	ERJ6ENF4303	M 430KOHM, 1/10W	1	
R431	ERJ6GEYJ103	M 10KOHM,J,1/10W	1	
R432	ERJ6GEYJ102	M 1KOHM,J,1/10W	1	
R433	ERJ6ENF1202	M 12KOHM, 1/10W	1	
R434	ERJ8GEY0R00	M 0 OHM, 1/8W	1	
R435	ERJ8ENF4303	M 43KOHM, 1/8W	1	
R436	ERJ8GEYJ153	M 15KOHM, J,1/8W	1	
R437	ERJ6GEYJ183	M 18KOHM,J,1/10W	1	
R438	ERJ6GEYJ331	M 330 OHM,J,1/10W	1	
R439	ERG12SJ120	M 12 OHM, J,1/2W	1	
R440	ERJ8GEYJ474	M 470KOHM, J,1/8W	1	
R441,42	ERJ6EKF6803	M 680KOHM, 1/10W	2	
R443	EVMAASA00B23	CONTROL 2KOHMB	1	
R444	ERJ6GEYJ123	M 12KOHM,J,1/10W	1	
R448,49	DOXGR10J0003	M 0.1OHM,J, 5W	2	
R450	ERJ6GEYJ102	M 1KOHM,J,1/10W	1	
R451	ERJ6GEYJ333	M 33KOHM,J,1/10W	1	
R452	ERJ6GEYJ103	M 10KOHM,J,1/10W	1	
R453	ERJ6GEYJ305	M 3MOHM,J,1/10W	1	
R454	ERJ6GEYJ103	M 10KOHM,J,1/10W	1	
R455	ERJ6GEYJ123	M 12KOHM,J,1/10W	1	
R456	ERJ6GEYJ333	M 33KOHM,J,1/10W	1	
R458	ERJ6GEYJ472	M 4.7KOHM,J,1/10W	1	
R459	ERJ6EKF6803	M 680KOHM, 1/10W	1	
R461	ERJ6GEYJ103	M 10KOHM,J,1/10W	1	
R462	ERJ6ENF4303	M 430KOHM, 1/10W	1	
R463	ERJ6GEYJ333	M 33KOHM,J,1/10W	1	
R464	ERJ6ENF3302	M 33KOHM, 1/10W	1	
R465	ERJ6ENF5603	M 560KOHM, 1/10W	1	
R467	ERJ6GEYJ102	M 1KOHM,J,1/10W	1	
R471	ERJ8GEYJ332	M 3.3KOHM, J,1/8W	1	
R472,73	ERJ6ENF5603	M 560KOHM, 1/10W	2	
R475	ERJ6EKF6803	M 680KOHM, 1/10W	1	

Ref. No.	Part No.	Part Name & Description	Pcs	Remarks
R476,77	ERJ14YJ181U	M 181 OHM, J,1/4W	2	
R478	ERJ8GEYJ220	M 22 OHM, J,1/8W	1	
R480	ERJ6ENF4702	M 47KOHM, 1/10W	1	
R482	ERJ8GEYJ220	M 22 OHM, J,1/8W	1	
R483	D0BF225JA030	M 22MOHM,J,0.05W	1	△
R487	ERJ6GEYJ472	M 4.7KOHM,J,1/10W	1	
R488	ERJ6GEYJ104	M 100KOHM,J,1/10W	1	
R490,91	ERJ6GEYJ473	M 47KOHM,J,1/10W	2	
R492	ERJ6GEY0R00	M 0 OHM, 1/10W	1	
R493	ERG12SJ120	M 12 OHM, J,1/2W	1	
R494-96	ERJ6ENF5603	M 560KOHM, 1/10W	3	
R497	ERJ6ENF1202	M 12KOHM, 1/10W	1	
R498	ERG3SJ101	M 100 OHM, J, 3W	1	
R499	D0BF394JA029	M 390KOHM,J,0.05W	1	△
R501	ERJ6GEYJ223	M 22KOHM,J,1/10W	1	
R502,03	ERJ6GEYJ104	M 100KOHM,J,1/10W	2	
R504	ERJ6GEYJ102	M 1KOHM,J,1/10W	1	
R505	ERJ8GEYJ330	M 33 OHM, J,1/8W	1	
R506	ERJ6GEYJ102	M 1KOHM,J,1/10W	1	
R507	ERJ6GEYJ221	M 220 OHM,J,1/10W	1	
R508	ERJ6GEYJ102	M 1KOHM,J,1/10W	1	
R509-11	ERJ6GEYJ104	M 100KOHM,J,1/10W	3	
R512	ERJ6GEYJ223	M 22KOHM,J,1/10W	1	
R513,14	ERJ6GEYJ104	M 100KOHM,J,1/10W	2	
R515,16	ERJ6GEYJ102	M 1KOHM,J,1/10W	2	
R517	ERJ6GEYJ103	M 10KOHM,J,1/10W	1	
R518	ERJ6GEYJ102	M 1KOHM,J,1/10W	1	
R519,20	ERJ6GEYJ104	M 100KOHM,J,1/10W	2	
R521,22	ERJ8GEYJ100	M 10 OHM, J,1/8W	2	
R523	ERJ6GEYJ473	M 47KOHM,J,1/10W	1	
R524	ERJ6GEYJ102	M 1KOHM,J,1/10W	1	
R525	ERJ6GEYJ473	M 47KOHM,J,1/10W	1	
R526,27	ERJ8GEYJ224	M 220KOHM, J,1/8W	2	
R528	ERJ6GEYJ4R7	M 4.7 OHM,J,1/10W	1	
R529	ERJ6GEYJ101	M 100 OHM,J,1/10W	1	
R530	ERJ6RBD3302	M 33KOHM,F,1/10W	1	
R532	ERJ6GEYJ102	M 1KOHM,J,1/10W	1	
R533	ERJ6GEYJ163	M 16KOHM,J,1/10W	1	
R534	ERJ6GEYJ473	M 47KOHM,J,1/10W	1	
R535,36	ERJ6GEYJ102	M 1KOHM,J,1/10W	2	
R537	ERJ6ENF1003	M 100KOHM, 1/10W	1	
R538	ERJ6GEYJ104	M 100KOHM,J,1/10W	1	
R539	ERJ6GEYJ103	M 10KOHM,J,1/10W	1	
R540,41	ERJ6GEYJ105	M 1MOHM,J,1/10W	2	
R542	ERJ6GEYJ102	M 1KOHM,J,1/10W	1	
R543	ERJ6GEYJ153	M 15KOHM,J,1/10W	1	
R544	ERJ6GEYJ331	M 330 OHM,J,1/10W	1	
R545	ERJ6GEYJ103	M 10KOHM,J,1/10W	1	
R546	ERJ6GEYJ102	M 1KOHM,J,1/10W	1	
R547	ERJ6GEYJ101	M 100 OHM,J,1/10W	1	
R548	ERJ6GEYJ102	M 1KOHM,J,1/10W	1	
R549	ERJ6GEYJ103	M 10KOHM,J,1/10W	1	
R550	ERJ6GEYJ473	M 47KOHM,J,1/10W	1	
R551	ERJ6GEYJ334	M 330KOHM,J,1/10W	1	
R552	ERJ6GEYJ103	M 10KOHM,J,1/10W	1	
R553	ERJ6GEYJ101	M 100 OHM,J,1/10W	1	
R554	ERJ6GEYJ102	M 1KOHM,J,1/10W	1	
R555,56	ERJ6GEYJ105	M 1MOHM,J,1/10W	2	
R557	ERJ6GEYJ104	M 100KOHM,J,1/10W	1	
R558	ERJ6GEYJ474	M 470KOHM,J,1/10W	1	
R559	ERJ6ENF8201	M 8.2KOHM, 1/10W	1	
R560	ERJ6ENF9101	M 9.1KOHM, 1/10W	1	
R561	ERJ6ENF5101	M 5.1KOHM, 1/10W	1	
R562	ERJ6ENF4701	M 4.7KOHM, 1/10W	1	
R563	ERJ6GEYJ2R2	M 2.2 OHM,J,1/10W	1	
R564	ERJ6GEYJ104	M 100KOHM,J,1/10W	1	
R565,66	ERJ6GEYJ105	M 1MOHM,J,1/10W	2	
R567,68	ERJ8ENF1004	M 100KOHM, 1/8W	2	
R569	ERJ6ENF3302	M 33KOHM, 1/10W	1	
R570	ERJ6GEYJ104	M 100KOHM,J,1/10W	1	
R571	ERJ6GEYJ105	M 1MOHM,J,1/10W	1	
R572,73	ERJ8ENF3900	M 390 OHM, 1/8W	2	
R574	ERJ6GEYJ331	M 330 OHM,J,1/10W	1	

Ref. No.	Part No.	Part Name & Description	Pcs	Remarks
R575	ERJ6GEYJ102	M 1KOHM,J,1/10W	1	
R576	ERJ6ENF1202	M 12KOHM, 1/10W	1	
R577,78	ERJ6GEYJ473	M 47KOHM,J,1/10W	2	
R579	ERJ6GEYJ103	M 10KOHM,J,1/10W	1	
R580,81	ERJ6GEYJ473	M 47KOHM,J,1/10W	2	
R582	ERJ6ENF1002	M 10KOHM, 1/10W	1	
R583	ERJ6GEYJ473	M 47KOHM,J,1/10W	1	
R584	ERJ6GEYJ103	M 10KOHM,J,1/10W	1	
R585	ERJ6GEYJ333	M 33KOHM,J,1/10W	1	
R586	ERJ6GEYJ473	M 47KOHM,J,1/10W	1	
R587	ERJ8RQJR22V	MO.22 OHM, 1/8W	1	
R588	ERJ8ENF3900	M 390 OHM, 1/8W	1	
R589,90	ERJ8GEYJ123	M 12KOHM, J,1/8W	2	
R591	ERJ6GEYJ105	M 1MOHM,J,1/10W	1	
R592	ERJ6ENF3001	M 3KOHM, 1/10W	1	
R593	ERJ6ENF5601	M 5.6KOHM, 1/10W	1	
R594	ERJ6GEYJ151	M 150 OHM,J,1/10W	1	
R595	ERJ8GEYJ222	M 2.2KOHM, J,1/8W	1	
R596	ERJ6GEYJ101	M 100 OHM,J,1/10W	1	
R597,98	ERJ6ENF3302	M 33KOHM, 1/10W	2	
R599,00	ERJ8ENF3900	M 390 OHM, 1/8W	2	
R601	ERJ6GEYJ473	M 47KOHM,J,1/10W	1	
R602	ERJ6ENF3301	M 3.3KOHM, 1/10W	1	
R603	ERJ6GEYJ333	M 33KOHM,J,1/10W	1	
R606	ERJ6ENF1201	M 1.2KOHM, 1/10W	1	
R607	ERJ6ENF2202	M 2.2KOHM, 1/10W	1	
R608	ERJ8GEYJ332	M 3.3KOHM, J,1/8W	1	
R609	ERJ6GEYJ102	M 1KOHM,J,1/10W	1	
R610,11	ERJ6GEYJ473	M 47KOHM,J,1/10W	2	
R612	ERJ6GEYJ222	M 2.2KOHM,J,1/10W	1	
R613	ERJ6ENF2402	M 24KOHM, 1/10W	1	
R614	ERJ6ENF3301	M 3.3KOHM, 1/10W	1	
R615	ERJ6GEYJ102	M 1KOHM,J,1/10W	1	
R616,17	ERJ6GEYJ103	M 10KOHM,J,1/10W	2	
R618	ERJ6GEYJ104	M 100KOHM,J,1/10W	1	
R619	ERJ8RQFR68	M 0.68OHM, J,1/8W	1	
R620	ERJ6GEYJ103	M 10KOHM,J,1/10W	1	
R621	ERJ8GEYJ123	M 12KOHM, J,1/8W	1	
R622	ERJ8ENF1503	M 15KOHM, 1/8W	1	
R624	ERX2SJR22	MO.22 OHM, J, 2W	1	
R626	ERJ8ENF1503	M 15KOHM, 1/8W	1	
R627	ERJ6GEYJ822	M 8.2KOHM,J,1/10W	1	
R628	EVMAASA00B33	CONTROL 3KOHMB	1	
R629	ERJ6GEYJ105	M 1MOHM,J,1/10W	1	
R630	ERJ8GEYJ472	M 4.7KOHM, J,1/8W	1	
R631	ERJ8GEYJ333	M 33KOHM, J,1/8W	1	
R632	ERJ6GEYJ221	M 220 OHM,J,1/10W	1	
R633	ERJ6GEYJ105	M 1MOHM,J,1/10W	1	
R634	ERJ8RQFR68	M 0.68OHM, J,1/8W	1	
R636	ERJ8ENF1503	M 15KOHM, 1/8W	1	
R637	ERJ8RQFR68	M 0.68OHM, J,1/8W	1	
R638	ERJ6GEYJ102	M 1KOHM,J,1/10W	1	
R639,40	ERJ8RQFR68	M 0.68OHM, J,1/8W	2	
R641	ERJ6GEYJ473	M 47KOHM,J,1/10W	1	
R642-44	ERJ8RQFR68	M 0.68OHM, J,1/8W	3	
R645	ERJ6GEYJ101	M 100 OHM,J,1/10W	1	
R646,47	ERJ8GEYJ223	M 22KOHM, J,1/8W	2	
R648	ERJ8ENF1503	M 15KOHM, 1/8W	1	
R649	ERJ6GEYJ223	M 22KOHM,J,1/10W	1	
R650	ERJ6GEYJ103	M 10KOHM,J,1/10W	1	
R651,52	ERJ6ENF1002	M 10KOHM, 1/10W	2	
R653	ERJ6ENF3302	M 33KOHM, 1/10W	1	
R654	ERJ8GEYJ220	M 22 OHM, J,1/8W	1	
R655	ERJ8RQJR22V	MO.22 OHM, 1/8W	1	
R656	ERJ6ENF4702	M 47KOHM, 1/10W	1	
R657	ERJ6GEYJ102	M 1KOHM,J,1/10W	1	
R658	ERJ6GEYJ105	M 1MOHM,J,1/10W	1	
R659	ERJ6ENF3002	M 30KOHM, 1/10W	1	
R660	ERJ6ENF1202	M 12KOHM, 1/10W	1	
R661	EVMEASA00B53	CONTROL 5KOHMB 0.3W	1	
R662	ERJ6ENF1503	M 15KOHM, 1/10W	1	
R664	ERJ6ENF9101	M 9.1KOHM, 1/10W	1	

Ref. No.	Part No.	Part Name & Description	Pcs	Remarks
R665	EVMEASA00B23	CONTROL 2KOHMB 0.3W	1	
R666	ERJ6GEYJ102	M 1KOHM,J,1/10W	1	
R667,68	ERJ8GEY0R00	M 0 OHM, 1/8W	2	
R669	ERJ6ENF1303	M 130KOHM, 1/10W	1	
R670	ERJ6GEYJ102	M 1KOHM,J,1/10W	1	
R671	EVMEASA00B14	CONTROL 10KOHMB 0.3W	1	
R672,73	ERJ6GEYJ102	M 1KOHM,J,1/10W	2	
R674	ERJ8GEYJ333	M 33KOHM, J,1/8W	1	
R675	ERJ6ENF2202	M 2.2KOHM, 1/10W	1	
R676	ERJ8GEYJ333	M 33KOHM, J,1/8W	1	
R677	ERJ6GEYJ474	M 470KOHM,J,1/10W	1	
R678	ERJ8GEY0R00	M 0 OHM, 1/8W	1	
R679,80	ERJ8RQJR22V	MO.22 OHM, 1/8W	2	
R682	ERJ6ENF2002	M 20KOHM, 1/10W	1	
R683	ERJ6GEYJ333	M 33KOHM,J,1/10W	1	
R684	ERJ6GEYJ103	M 10KOHM,J,1/10W	1	
R685,86	ERJ6GEYJ102	M 1KOHM,J,1/10W	2	
R687	ERJ6GEYJ103	M 10KOHM,J,1/10W	1	
R688,89	ERJ6GEYJ102	M 1KOHM, J,1/10W	2	
R690	ERJ6GEYJ4R7	M 4.7 OHM,J,1/10W	1	
R691	ERJ6GEYJ104	M 100KOHM,J,1/10W	1	
R692	ERJ6GEYJ472	M 4.7KOHM,J,1/10W	1	
R693	ERJ6GEYJ103	M 10KOHM,J,1/10W	1	
R695	ERJ6ENF1602	M 16KOHM, 1/10W	1	
R696	ERJ8GEYJ100	M 10 OHM, J,1/8W	1	
R697	ERJ6GEYJ4R7	M 4.7 OHM,J,1/10W	1	
R698	ERJ8RQJR22V	MO.22 OHM, 1/8W	1	
R700-08	ERJ8GEYJ105	M 1MOHM, J,1/8W	9	
R711	ERJ8RQJR22V	MO.22 OHM, 1/8W	1	
R712	ERJ6GEYJ4R7	M 4.7 OHM,J,1/10W	1	
R713	ERJ8GEYJ472	M 4.7KOHM, J,1/8W	1	
R714	ERJ6GEYJ101	M 100 OHM,J,1/10W	1	
R715	ERDS2TJ101	C 100 OHM, J,1/4W	1	
R921	ERJ6RBD3302	M 33KOHM,F,1/10W	1	
R922	ERJ6GEYJ101	M 100 OHM,J,1/10W	1	
R931	ERJ6ENF3302	M 33KOHM, 1/10W	1	
R932	ERJ6GEYJ104	M 100KOHM,J,1/10W	1	
R933	ERJ6GEYJ102	M 1KOHM,J,1/10W	1	
R935	ERJ6GEYJ104	M 100KOHM,J,1/10W	1	
R936	ERJ6GEYJ103	M 10KOHM,J,1/10W	1	
R937	ERJ6GEYJ102	M 1KOHM,J,1/10W	1	
R938	ERJ6GEYJ472	M 4.7KOHM,J,1/10W	1	
R939,40	ERJ6GEYJ102	M 1KOHM,J,1/10W	2	
R943	ERJ6GEYJ105	M 1MOHM,J,1/10W	1	
R945	ERJ6GEYJ223	M 22KOHM,J,1/10W	1	
R946	ERJ6GEYJ333	M 33KOHM,J,1/10W	1	
R947	ERJ8GEYJ331	M 330 OHM, J,1/8W	1	
R950	ERJ6GEYJ105	M 1MOHM,J,1/10W	1	
R951,52	ERJ8GEYJ100	M 10 OHM, J,1/8W	2	
R953	ERJ6GEYJ222	M 2.2KOHM,J,1/10W	1	
R955	ERJ6GEYJ473	M 47KOHM,J,1/10W	1	
R956	ERJ6GEYJ104	M 100KOHM,J,1/10W	1	
RL402,03	TSEH8011	RELAY	2	△
S401,02	J0LT00000009	SWITCH	2	△
T401	G4D4A0000119	SWITCHING TRANSFORMER	1	
T402	G4D1A0000098	SWITCHING TRANSFORMER	1	△
T404	G4D4A0000118	SWITCHING TRANSFORMER	1	△
T407	ETQ11K5AZ	CHOKE TRANS	1	△
T410	ETS25AF115AH	SWITCHING TRANS	1	△
T601	G4D2A0000264	SWITCHING TRANS	1	
W9,10	J0JKB0000037	FLAT CORE	2	
X501	H2B400400021	CRYSTAL	1	

Ref. No.	Part No.	Part Name & Description	Pcs	Remarks
Z1,Z2	K4ZZ01000206	TERMINAL	2	
Z420	TMM23417	CLAMPER	2	
Z450-53	EYF52BCY	FUSE HOLDER	4	
ZN401	ERZVGED621T2	VARISTOR	1	△
ZN402	D4EAD7510001	VARISTOR	1	△
ZN404	ERZVGAD681T2	VARISTOR	1	△
ZN405,06	ERZVA7D511	VARISTOR	2	△