

Service Manual



LCD Television

TX-24E200E / TX-24E303E
TX-24EW334 / TX-24E302B
TX-32E200E / TX-32E302B
TX-32E303E / TX-32EW334
TX-39EW334 / TX-43E200E
TX-43E303E / TX-43E302B

MB140 Chassis

Warning

This service information is designed for experienced repair technicians only and is not designed for use by the general public. It does not contain warnings or cautions to advise non-technical individuals of potential dangers in attempting to service a product. Products powered by electricity should be serviced or repaired only by experienced professional technicians. Any attempt to service or repair the product or products deal within this service information by anyone else could result in serious injury or death.

IMPORTANT SAFETY NOTICE

There are special components used in this equipment which are important for safety. These parts are marked  in the Schematic Diagrams, Circuit Board Diagrams, Explorer Views and Replacement Parts List. It is essential that these critical parts should be replaced with manufacturer's specified parts to prevent shock, fire or other hazards. Do not modify the original design without permission of manufacturer.

CONTENTS

SAFETY PRECAUTIONS	2
GENERAL GUIDE LINES.....	2
TOUCH – CURRENT CHECK.....	2
PREVENTION OF ELECTROSTATIC DISCHARGE (ESD) TO ELECTROSTATICALLY SENSITIVE (ES) DEVICES	3
ABOUT LEAD FREE SOLDER (PBF).....	4
SERVICE NAVIGATION	5
SPAREPARTS IDENTIFICATION	7
SERVICE MODE FUNCTION	7
SOFTWARE UPDATE	9
HOTEL MODE	9
TROUBLESHOOTING.....	13
PARTS LOCATION.....	19
LOCATION OF LEAD WIRING	20
BLOCK DIAGRAM	24
EXPLODED VIEW	25

Prevention of Electrostatic Discharge (ESD) to Electrostatically Sensitive (ES) Devices

Some semiconductor (solid state) devices can be damaged easily by static electricity. Such components commonly are called Electrostatically Sensitive (ES) Devices. Examples of typical ES devices are integrated circuits and some field-effect transistors and semiconductor "chip" components. The following techniques should be used to help reduce the incidence of component damage caused by electrostatic discharge (ESD).

1. Immediately before handling any semiconductor component or semiconductor-equipped assembly, drain off any ESD on your body by touching a known earth ground. Alternatively, obtain and wear a commercially available discharging ESD wrist strap, which should be removed for potential shock reasons prior to applying power to the unit under test.
2. After removing an electrical assembly equipped with ES devices, place the assembly on a conductive surface such as aluminum foil, to prevent electrostatic charge build up or exposure of the assembly.
3. Use only a grounded-tip soldering iron to solder or unsolder ES devices.
4. Use only an anti-static solder removal device. Some solder removal devices not classified as "anti-static (ESD protected)" can generate electrical charge sufficient to damage ES devices.
5. Do not use freon-propelled chemicals. These can generate electrical charges sufficient to damage ES devices.
6. Do not remove a replacement ES device from its protective package until immediately before you are ready to install it. (Most replacement ES devices are packaged with leads electrically shorted together by conductive foam, aluminum foil or comparable conductive material).
7. Immediately before removing the protective material from the leads of a replacement ES device, touch the protective material to the chassis or circuit assembly into which the device will be installed.

Caution

Be sure no power is applied to the chassis or circuit, and observe all other safety precautions.

8. Minimize bodily motions when handling unpackaged replacement ES devices. (Otherwise harmless motion such as the brushing together of your clothes fabric or the lifting of your foot from a carpeted floor can generate static electricity (ESD) sufficient to damage an ES device).

IMPORTANT SAFETY NOTICE

There are special components used in this equipment which are important for safety. These parts are marked by  in schematic diagrams, exploded views and replacement parts list. It is essential that these critical parts should be replaced with manufacturer's specified parts to prevent shock, fire, or other hazards. Do not modify the original design without permission of manufacturer.

About lead free solder (PbF)

Note: Lead is listed as (Pb) in the periodic table of elements.

In the information below, Pb will refer to Lead solder, and PbF will refer to Lead Free Solder.

The Lead Free Solder used in our manufacturing process and discussed below is (Sn+Ag+Cu).

That is Tin (Sn), Silver (Ag) and Copper (Cu) although other types are available.

This model uses Pb Free solder in it's manufacture due to environmental conservation issues. For service and repair work, we'd suggest the use of Pb free solder as well, although Pb solder may be used.

PCBs manufactured using lead free solder will have the PbF within a leaf Symbol

 stamped on the back of PCB.

Caution

- Pb free solder has a higher melting point than standard solder. Typically the melting point is 50 ~ 70 °F (30~40°C) higher. Please use a high temperature soldering iron and set it to 700 ± 20 °F (370 ± 10 °C).
- Pb free solder will tend to splash when heated too high (about 1100 °F or 600 °C).
If you must use Pb solder, please completely remove all of the Pb free solder on the pins or solder area before applying Pb solder. If this is not practical, be sure to heat the Pb free solder until it melts, before applying Pb solder.
- After applying PbF solder to double layered boards, please check the component side for excess solder which may flow onto the opposite side. (see Fig.3)

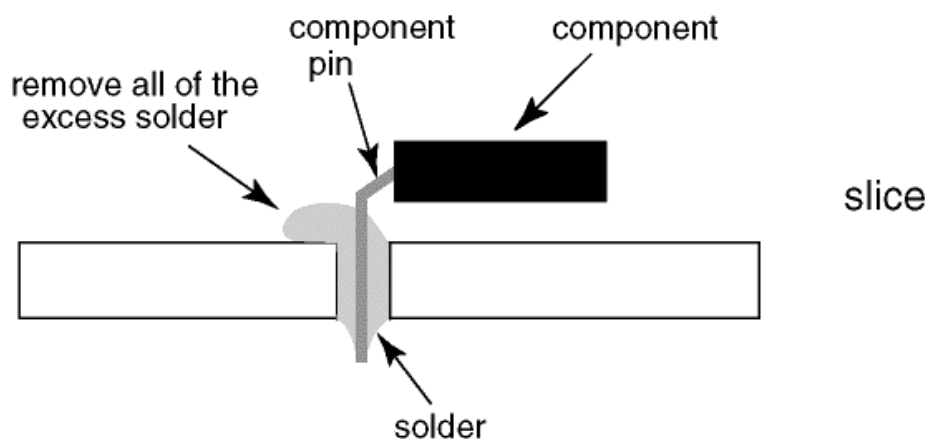

Fig.3

Suggested Pb free solder

There are several kinds of Pb free solder available for purchase. This product uses Sn+Ag+Cu (tin, silver, copper) solder. However, Sn+Cu (tin, copper), Sn+Zn+Bi (tin, zinc, bismuth) solder can also be used. (see Fig.4)

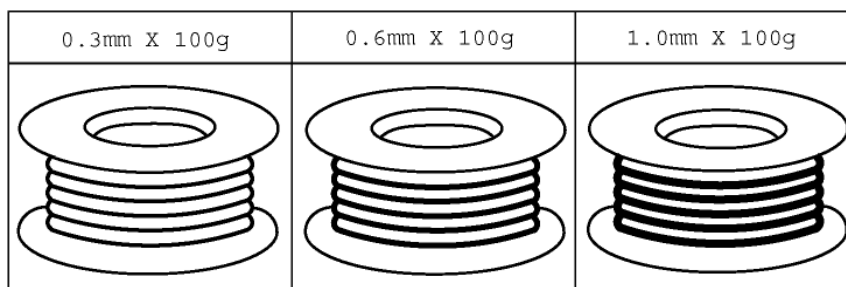
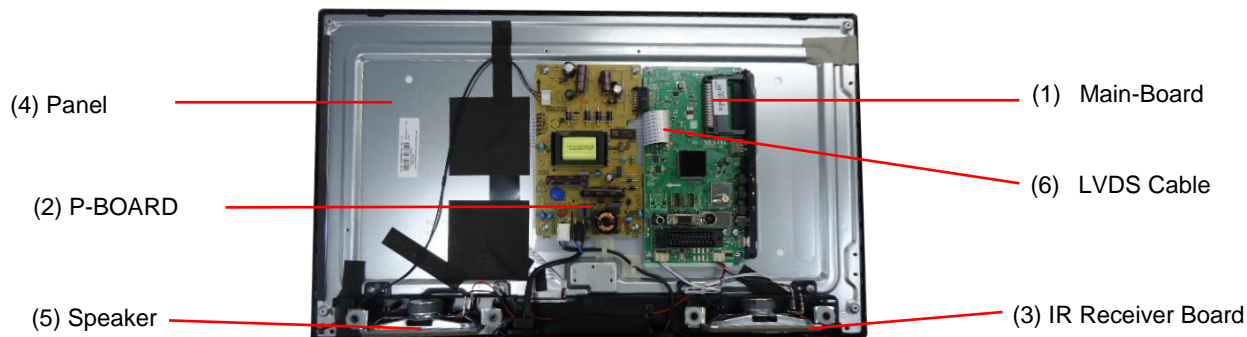

Fig.4

Service Navigation Chassis Board Layout

TX-24E200E / TX-24E303 / TX-24EW334 / TX-24E302



Name	Function	Position
Main-Board	AV Terminal, HDMI, USB, TUNER DVB-A/T/C, CI-Slot, Headphones, Speaker out,	1
P-Board	Main Input, Power Supply, Back Light	2
IR Receiver	Remote Receiver	3
Panel	LCD-Panel / Backlight	4
Speaker		5
LVDS Cable		6

TX-32E200E / TX-32E303 / TX-32EW334 / TX-32E302

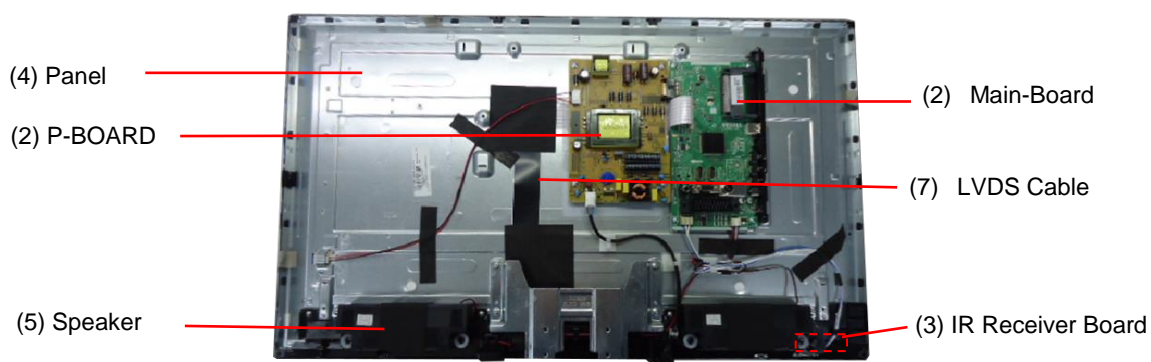

Name	Function	Position
Main-Board	AV Terminal, HDMI, USB, TUNER DVB-A/T/C, CI-Slot, Headphones, Speaker out,	1
P-Board	Main Input, Power Supply, Back Light	2
IR Receiver	Remote Receiver	3
Panel	LCD-Panel / Backlight	4
Speaker		5
LVDS Cable		6

TX-39EW334

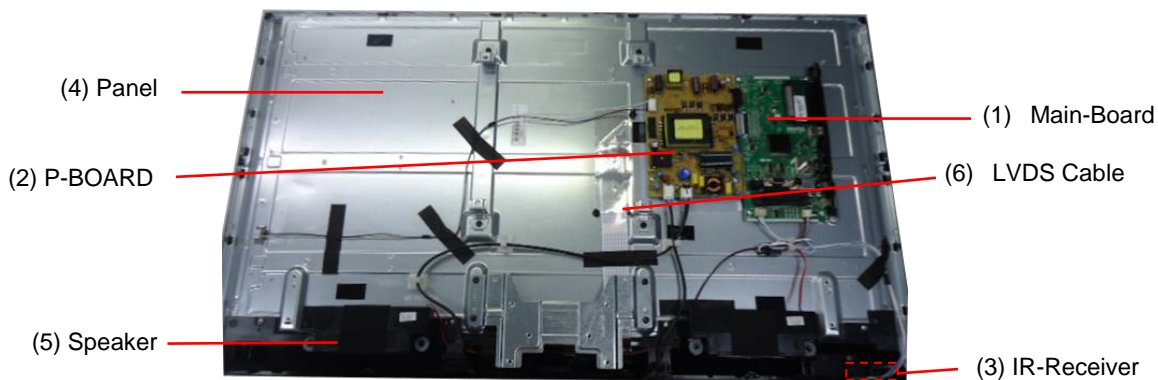

Name	Function	Position
Main-Board	AV Terminal, HDMI, USB, TUNER DVB-A/T/C, CI-Slot, Headphones, Speaker out,	1
P-Board	Main Input, Power Supply, Back Light	2
IR Receiver	Remote Receiver	3
Panel	LCD-Panel / Backlight	4
Speaker		5
LVDS Cable		6

TX-43E200E / TX-43E303E / TX-43E302

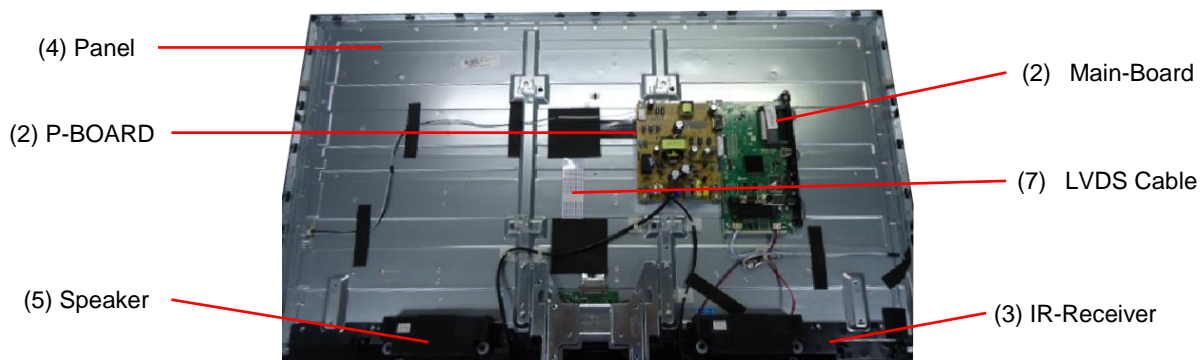

Name	Function	Position
Main-Board	AV Terminal, HDMI, USB, TUNER DVB-A/T/C, CI-Slot, Headphones, Speaker out,	1
P-Board	Main Input, Power Supply, Back Light	2
IR Receiver	Remote Receiver	3
Panel	LCD-Panel / Backlight	4
Speaker		5
LVDS Cable		6

Spareparts Identification

In order to properly identify correct Parts Order No. for each unit, it is required to respect not only the Model number, but also the so called Product Code. Both information can be obtained from rating label on the rear cover of the unit. In the below example the key information would be:

Model TX-32EW334

Product Code 10110485 (first 8 digits of upper code)

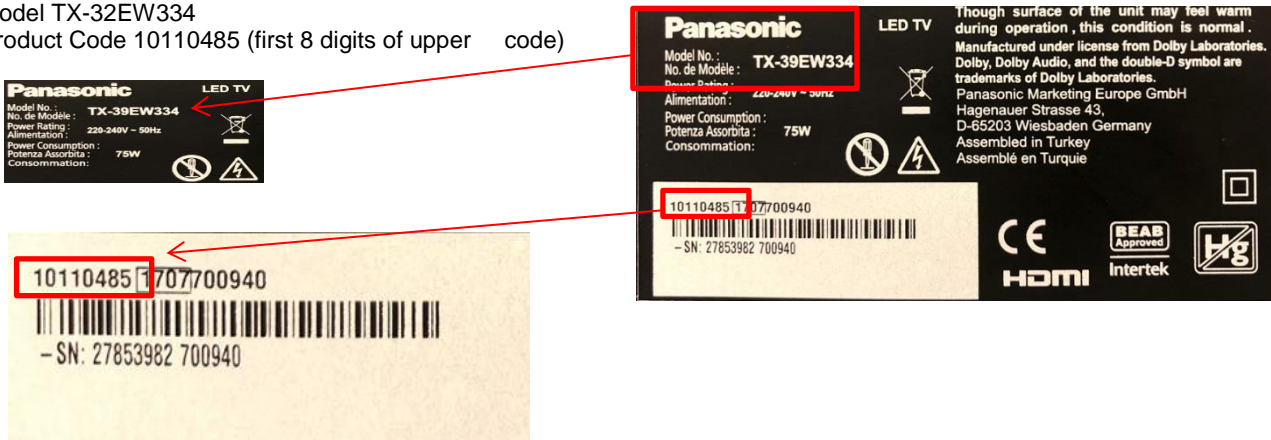

Then login to **PanaNet** and download concerned parts list. **Model No. and Production Code** are part of the file name.

Service Menu

You can see the service menu main screen below. You can check SW releases by using this menu. Some Video settings can be done.

How to enter into Service Menu

First press [MENU] button on the remote control, then type "4725" and the Service Main Menu will appear.

How to exit

To return from Service Menu simply press [EXIT] on remote control.

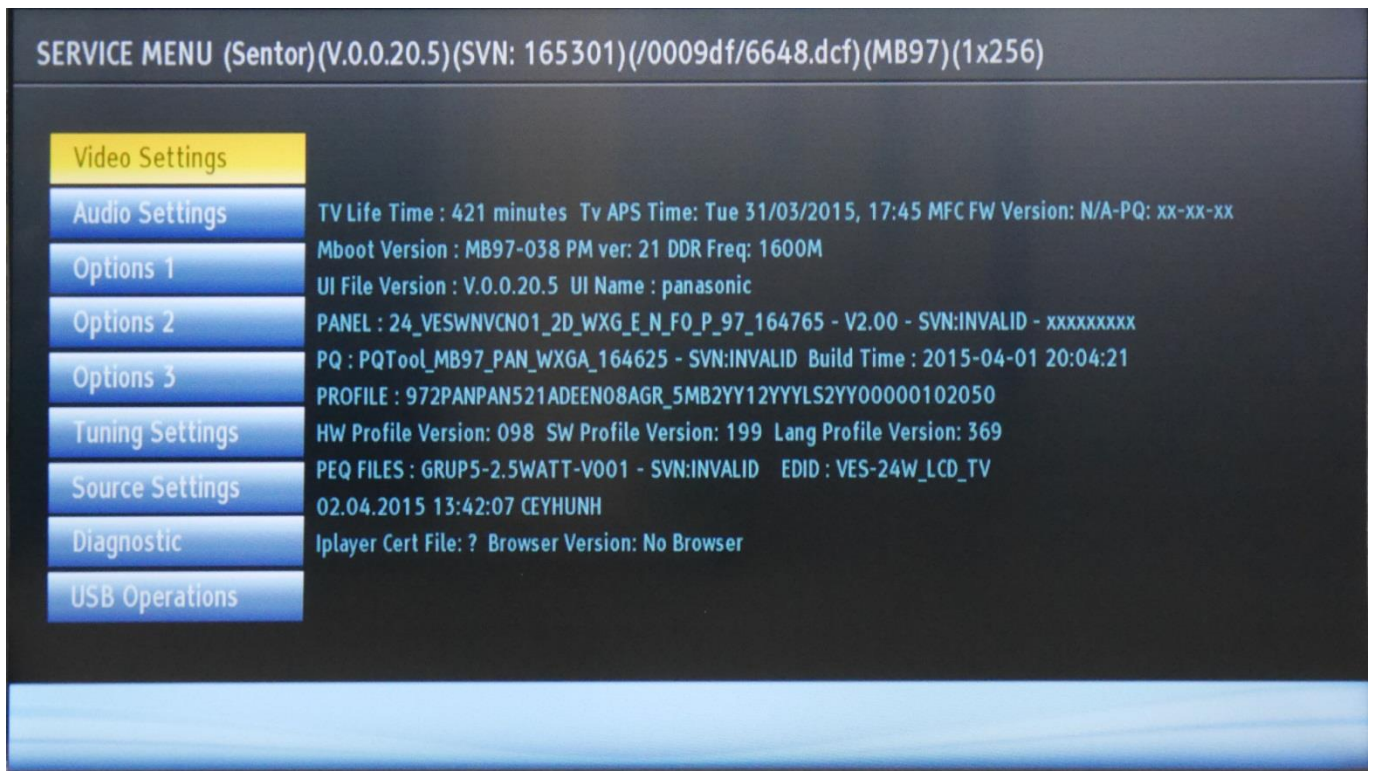

VIDEO SETTINGS

RF AGC SECAM	9
RF AGC NEIGHBOUR NO IMAGE NO	3
RF AGC NEIGHBOUR NO IMAGE YES	3
RF AGC NEIGHBOUR YES IMAGE NO	6
RF AGC NEIGHBOUR YES IMAGE YES	6
RF AGC TEST	9
SPREAD SPEC RANGE	0
SPREAD SPEC SCALE	0
SPREAD SPEC STEP	0
SPREAD SPEC Mf:Mr	0

Return
 Exit

DIAGNOSTIC

Remote control test	OK
Video Pattern Test	OK
UHF test	OK
VHF test	OK
Factory reset	OK
Test mode service list	OK
Tuner I2C	OK
DVB-T2 Demod I2C	OK
EDID status	OK
HDCP status	OK

Press any key to test
 Return
 Exit

SOFTWARE UPDATE

MAIN SW UPDATE

In MB140R3 project please follow the update procedure below:

1. The files

mb140.bin
mb140_mboot.bin
usb_auto_update_G9.txt

should be copied directly into root path of an empty flash memory (not in a folder).

2. Insert flash memory into the TV while TV is disconnected from AC mains.
3. Reconnect TV to main power and keep pressing the OK button on remote until LED starts blinking.
4. Now SW update is in progress and LED flashes until update is completed.

Hotel Mode

HOTEL TV FEATURES

The HOTEL TV is a special mode which restricts some operations of TV. This allows the customer to use the TV in hotels, in prisons or in hospitals. The restrictions of a hotel TV are basically given below.

1. The user cannot increase the volume above a specified limit / Volume can be fixed to a certain level
2. The user could enable headphone direct volume control.
3. The user cannot reach some menus.
4. There is panel lock feature which does not allow the user to use the keypad touch on the TV set when it is active.
5. Start up source position can be limited for the user.
6. Last status could be used or not
7. Teletext could be disabled or enabled.
8. NVRAM data (like service list and user preferences, etc.) could be copied or set via USB device
9. Pin8 could be used or not

HOTEL TV MENU

To enter hotel menu, please press MENU(M) button on remote control, then key in "7935" and the hidden Hotel TV Menu will appear on the screen

HOTEL MODE

Setting "Hotel Mode" item 'On' activates hotel mode. In other words user can do only what he/she is allowed to do. Restriction level can be determined by using other items on menu namely Volume Limit, Panel Button, OSD Disable. In hotel mode, users can not reach channel table and install menu so they could not change any program information.

Last Status

Setting "Last Status" item to 'On' enable TV open with the closing status. Otherwise, if "Last Status" item is set 'Off' TV opens with *standby* status.

Panel Lock

Enables (Panel Lock = On) or prohibits (Panel Lock = Off) the use of front panel buttons.

RCU Inhibit

If OFF is selected TV will go on normal operation. If It is ON RCU will not function in any menu(including no menu) except this menu. To turn this option OFF later, "hotel TV menu shortcut" (MENU(M)-7-9-3-5) can be used to pop up this menu,

Startup Position

Specifies the starting channel when TV is switched ON. May take one of following values:

AUTO

- TV is opened using standby key or digit keys: Last channel or last external source when TV is turned off

TV

- TV is opened using standby key: TV channel number that is specified on field **Startup Channel**
- TV is opened using digit keys: Corresponding channel

Other external sources (EXT1, HDMI2, PC, FAV, SVHS etc.)

- TV is opened using standby key or digit keys: Specified external source

Startup Channel

Specifies the starting TV channel's ID which will be tuned when startup position is TV.

Volume Limit

Sets the maximum value the volume can have. "Volume Limit" can take values between 0-63.

Fixed Volume Enable

Enables (Fixed Volume Enable = On) or prohibits (Fixed Volume Enable = Off) the use of fixed volume value which is set by menu item "Fixed Volume Value". If Fixed Volume Enable is ON, volume cannot be set to a value other than the Fixed Volume Value.

Fixed Volume Value

Sets the fixed value the volume can have. If Fixed Volume Limit is ON, volume is set with the value here.

Headphone Direct Volume

Enables the remote controller volume +/- buttons to change the headphone volume directly. When this features is active, volume +/- buttons changes only headphone value, and to change the TV main sound it can be control from sound OSD dialog only.

OSD Disable

Disables either only Setup menu or all menus, both in analog and digital (IDTV) mode.

All Menus : All menus (MAIN, SOUND, PICTURE, SETTINGS, INSTALLATION) are invisible.

OSD Disable = Disable Setup Menus : Only SETUP menus are invisible.

Invisible Setup Menus are:

Main menu: Installation, Channel list

Settings menu: Language, parental, Sources, Other settings

Teletext

Enables (Teletext = On) or prohibits (Teletext = Off) the use of teletext (or MHEG if available)

WakeUp Time Channel

To choose the TV set wake up channel.

Wakeup Time Volume

To modify the volume of TV wake up volume (It cant be set higher volume than volume limit).

Copy To USB

There are two steps and both are independent of each other.

Copy the updated welcome image to USB as "hotel_wel.png"

Copy NVRAM data (service list, preferences, etc.) to USB device. On MB9x all nvrAm data is stored in 8x32KB Flash files named as Flash0.bin, Flash1.bin ... Flash7.bin. When Copy to USB is called, those files are copied from TV to USB. Then they can be used for various purposes testing on another TV or testing/debugging on observatory etc. Note that USB should be plugged before this operation.

Copy From USB

There are two steps and both are independent of each other.

If there is file named "hotel_wel.png" in directory "welcome_image". It is copied to tv to use as welcome image. Copy from USB device data to NVRAM. Just the reverse operation done by copy to USB call. Previously copied nvrAm files (Flashx.bin) are copied into TV. If there is no flash file or some of them are available on USB, the available ones are copied. If no USB is connected, nothing happens.

Note : For Clone function USB stick (Copy to USB – Copy from USB) must be formatted to FAT32. If USB is not formatted to FAT32 the other TVs will not accept cloned data and performance issues will result

USB Option

If ON is selected TV will go on normal operation. If It is OFF USB device will not receive on none of the USB ports

Fixed Pic. Mode

If OFF is selected TV will go on normal operation. If It is ON Main menu/Picture quick menu/mode and quick menu/picture zoom will be inaccessible.

Digital Tuner

If ON is selected TV will go on normal operation. If It is OFF TV will display "no signal" message when tuned to digital channels existing in active channel list, and digital channels will not be detected in auto or manual searches.

Multiple RC Support

If OFF is selected TV will go on normal operation. If It is ON RCU type (system code) that is chosen in "RCU program menu" will be used. "RCU program menu" can be opened by RETURN-1-2-3-4 shortcut. Note: For any MHEG supporting services sequence should be INFO-RETURN-1-2-3-4. The multiple RC support is works on RC5 type of remote controllers. To active this feauters, the hotel mode should be active and from the hotel mode configuration menu, Multiple RC support should be set as ON.

RC Key	System Code
1	1
2	0
3	2
4	3

Welcome message

As default behaviour a welcome message image will be displayed (if hotel mode is enabled). The image will stay on screen until user presses a key. On the bottom side of image there is an message (osd message) displaying "press any key". Welcome image can be changed through USB (described in "copy from USB" section). A default welcome image is available. Welcome images are png files with the resolution of 960X540.

Signal Lost (no signal) message

As default behaviour, if there is no signal the same welcome image is displayed. This time osd message is "no signal".

Internal Clock

If hotel mode is active a new function (add wake up timer) will be available in Settings/Timers menu. That function will open a new menu to set wake up time. After timer is saved tv can wake up automatically on desired time. If alarm option was selected as "on" after wake up tv will show welcome image and an alarm will be heard. Then any key will stop alarm and welcome image. If alarm option was selected as "off" after wake up tv will not show welcome image and the alarm will not be activated.

There is a “wakeup time channel” option in hotel mode menu, Its used to set the channel, whose time information to be used for wakeup timer. If this option is “0” time information of the channel which is being watched when timer menu is opened, will be used. Otherwise a “please wait” message will be displayed before the menu is open and during “please wait” time information of the channel will be get. (This can take up to 30s). The “wakeup time channel” should be a digital service.

Pin8

If ON is selected Pin8 will go on normal operation. If It is OFF Pin8 ignored.

NIT Update

Enables/disables NIT (i.e. Network Information Table) updates. Default value is ON.

EPG enable/disable

Enables/disables EPG (Electronic Program Guide) function.

Reset to Default Values

This resets all option of Hotel TV Menu to their default values.

TROUBLESHOOTING

No Backlight Problem

Problem: If TV is working, led is normal and there is no picture and backlight on the panel.

Possible causes: Backlight pin, dimming pin, backlight supply, stby on/off pin

BACKLIGHT_ON/OFF pin should be high when the backlight is ON. BACKLIGHT_ON/OFF must be low when the backlight is OFF. If it is a problem, please check this pin and the panel cables. Also it can be tested in TP72 in main board.

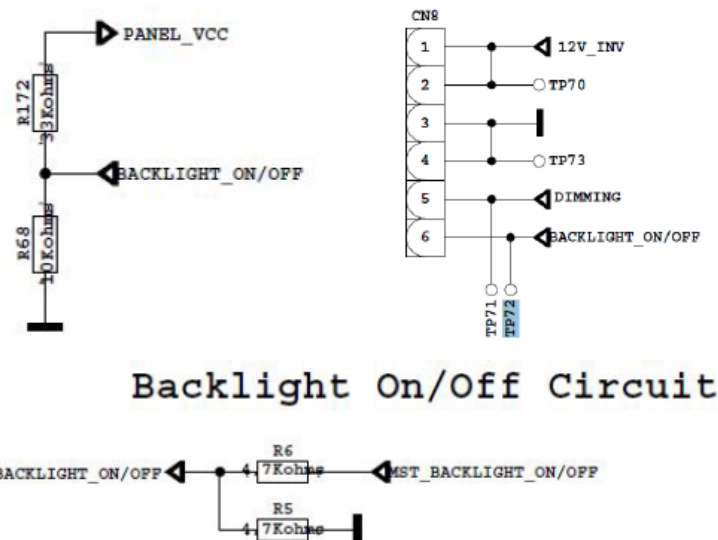

Dimming pin should be high or square wave in open position. If it is low, please check TP81 for Mstar side and panel or power cables, connectors.

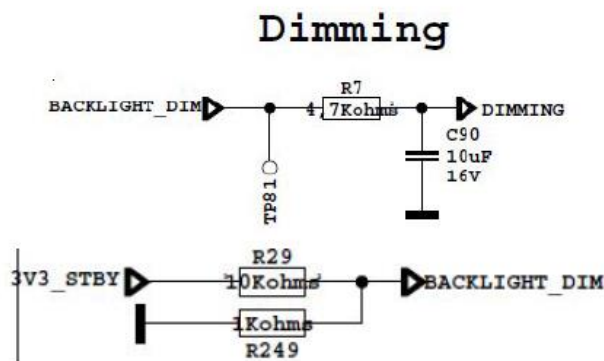

Backlight power supply should be in panel specs. Please check Q23, shown below; also it can be checked TP82.

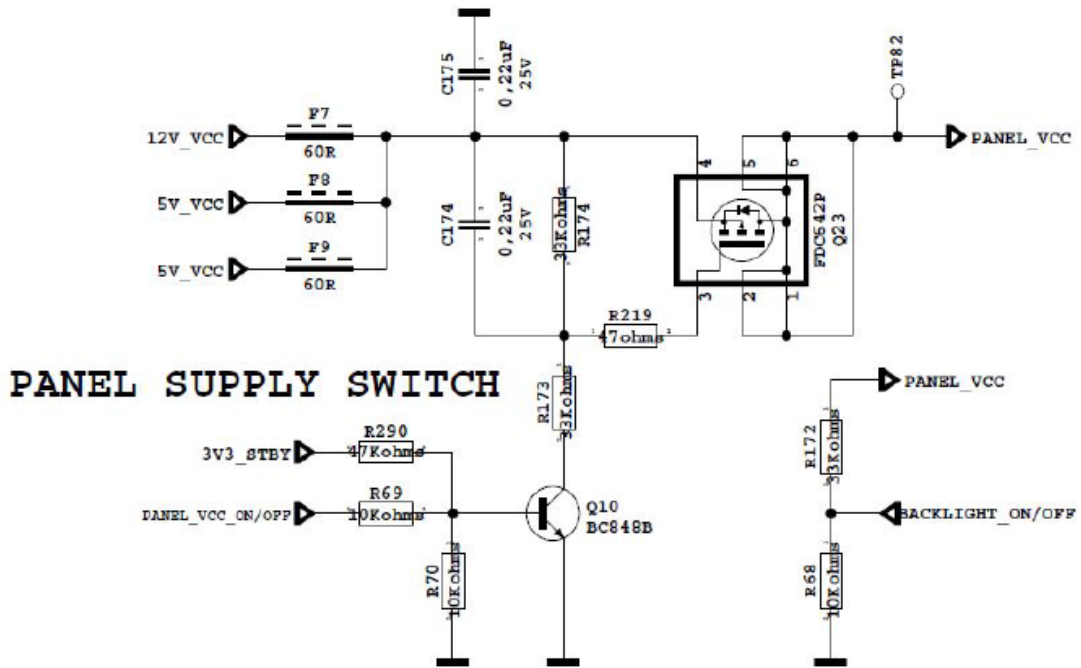

STBY_ON/OFF should be low for TV on condition, please check Q8's collector.

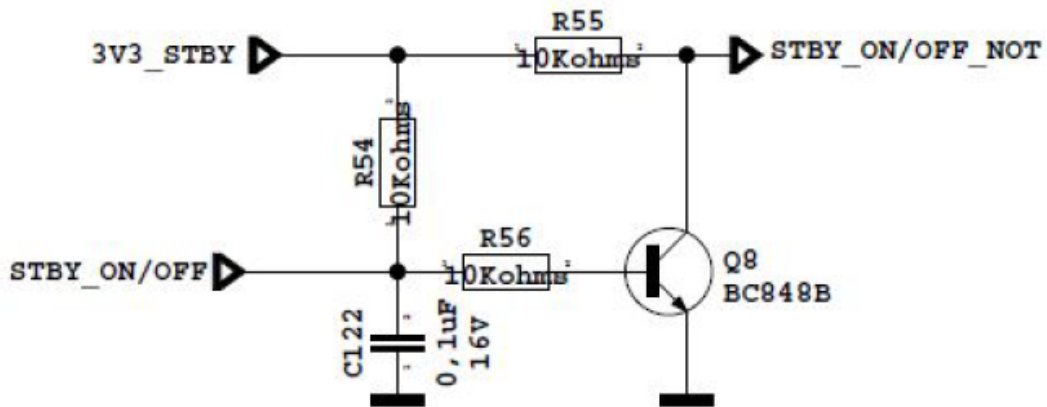

CI Modul Problem

Problem: CI is not working when CI module inserted.

Possible causes: Supply, supply control pin, detects pins, mechanical positions of pins.

- CI supply should be 5V when CI module inserted. If it is not 5V please check VCC_PCMCIA, this pin should be low.

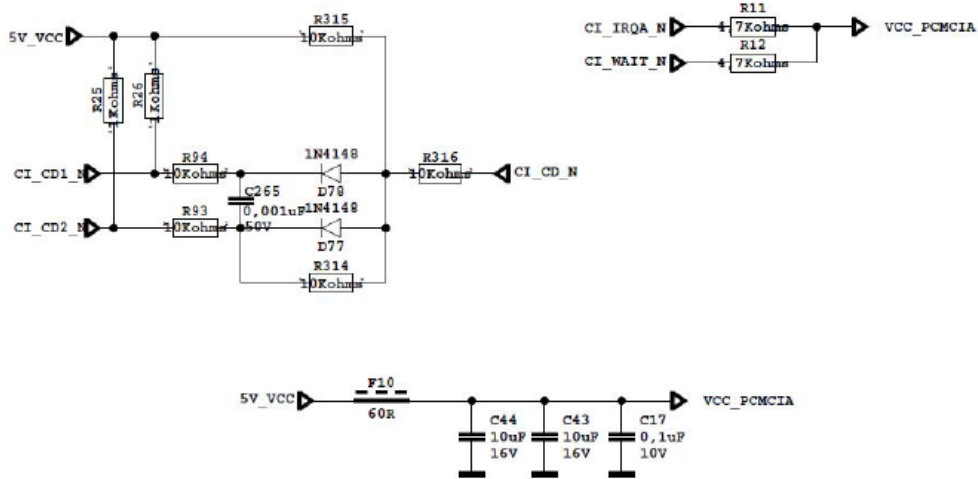

- Please check mechanical position of CI module. Is it inserted properly or not?
- Detect ports should be low. If it is not low please check CI connector pins, CI module pins.

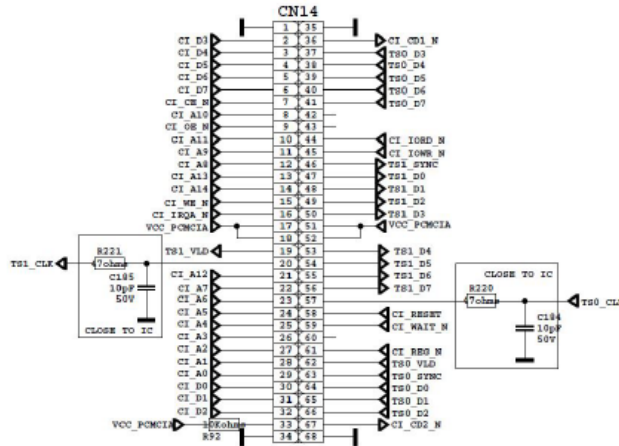

Staying in Stand-by Mode

Problem: Staying in stand-by mode, no other operation.

This problem indicates a short on Vcc voltages. Protect pin should be logic high while normal operation. When there is a short circuit protect pin will be logic low. If you detect logic low on protect pin, unplug the TV set and control voltage points with a multimeter to find the shorted voltage to ground.

Standby On/Off problem

Problem: Device can not boot, TV hangs in standby mode.

There may be a problem about power supply. Check main supplies with a voltage-meter. Also there may be a problem about SW. Try to update TV with latest SW. Additionally it is good to check SW printouts via Teraterm. These printouts may give a clue about the problem. You can use Scart-1 for terraterm connection.

No Signal Problem

Problem: No signal in DVB-T/T2/C mode.

Check tuner supply voltage; 3V3_TUNER. Check tuner options are correctly set in Service menu. Check AGC voltage at TUNER_IF_AGC pin of tuner.

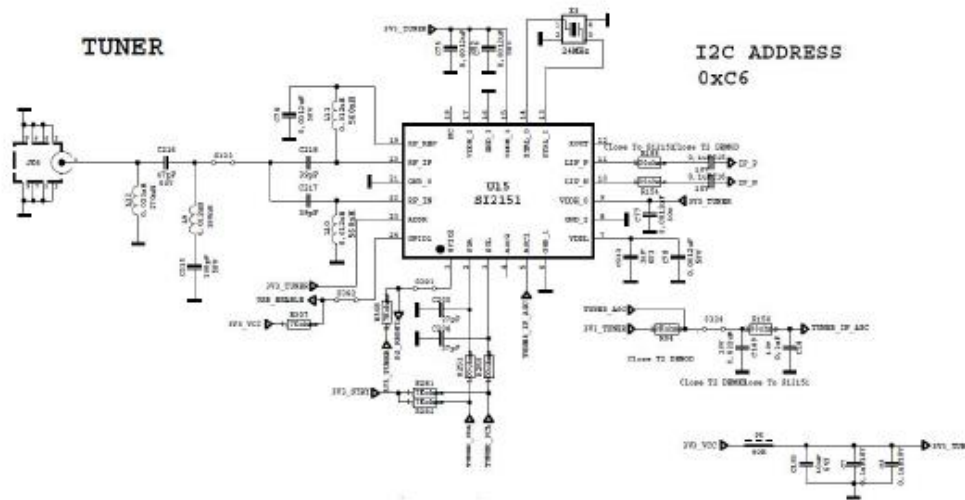

Problem: No signal or Low signal in DVB-S/S2 mode.

Check signal cables and LNB voltage, if there is no problem, check TS2022 supply voltage.

If it is OK, then measure the voltage from the PIN20 of U16.

If the PIN20 voltage is equal to 0V, please check I2C waveforms and software. If the PIN20 voltage is lower than 1V(e.g: 0.8V or 0.3V), change the U16 with a new part.

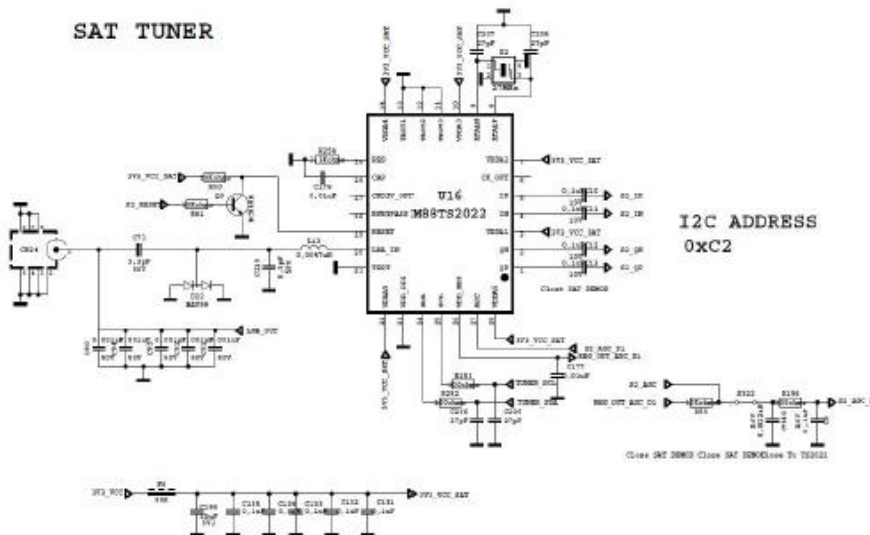

Parts location



Pos.	Name
1	Remote Control
2	Main power switch
3	IR-Remote Receiver (K-Board)
4a	CI-slot, USB, AV-in, HeadPhone, HDMI
5	Speaker
6	Operation Panel
7	SPDIF, SCART, VGA, ANT.,HDMI1/2, LNB
8	Stand Foot

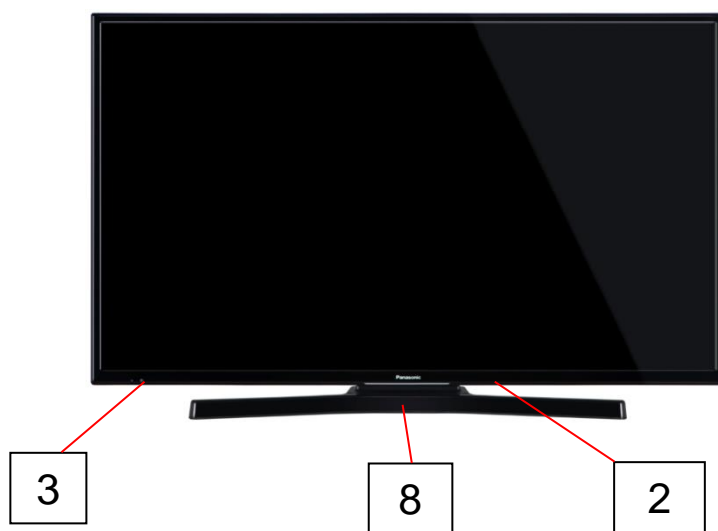
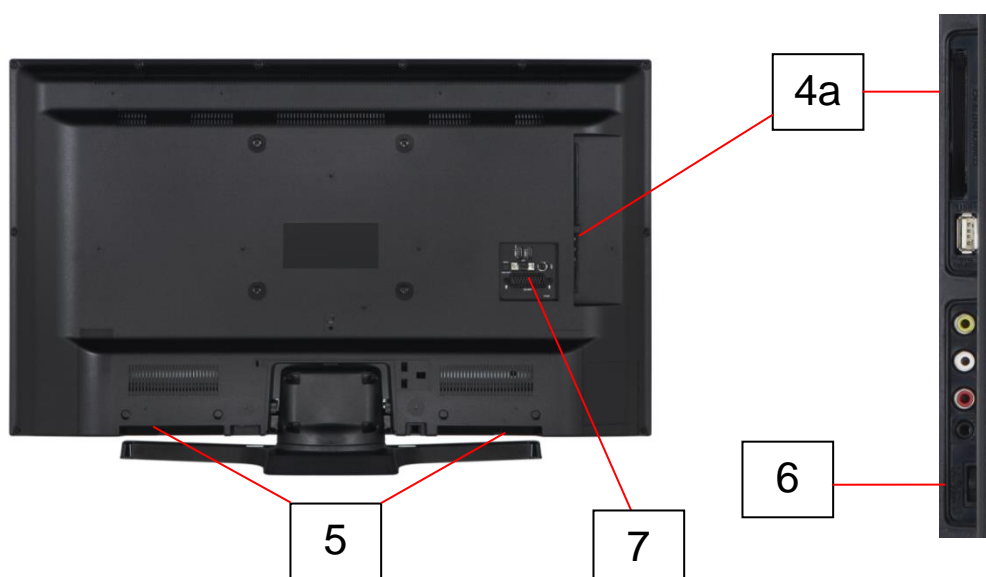

Location of Lead Wiring

TX-24E200E / TX-24E303E / TX-24EW334 / TX-24E302

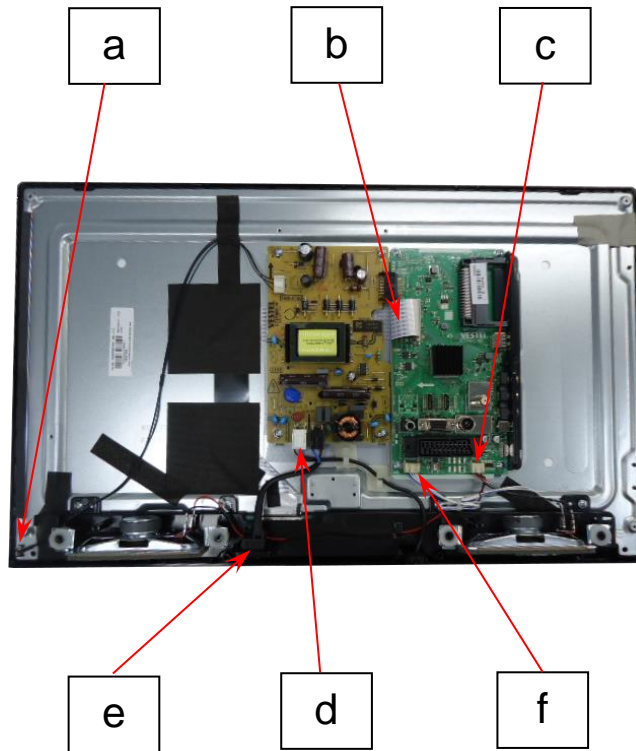

a	Back Light
b	LVDS Cable
c	Speaker connection
d	AC-Mains lead
e	Main power switch
f	IR-Remote Receiver

Location of Lead Wiring

TX-32E200E / TX-32E303 / TX32EW334 / TX32E302

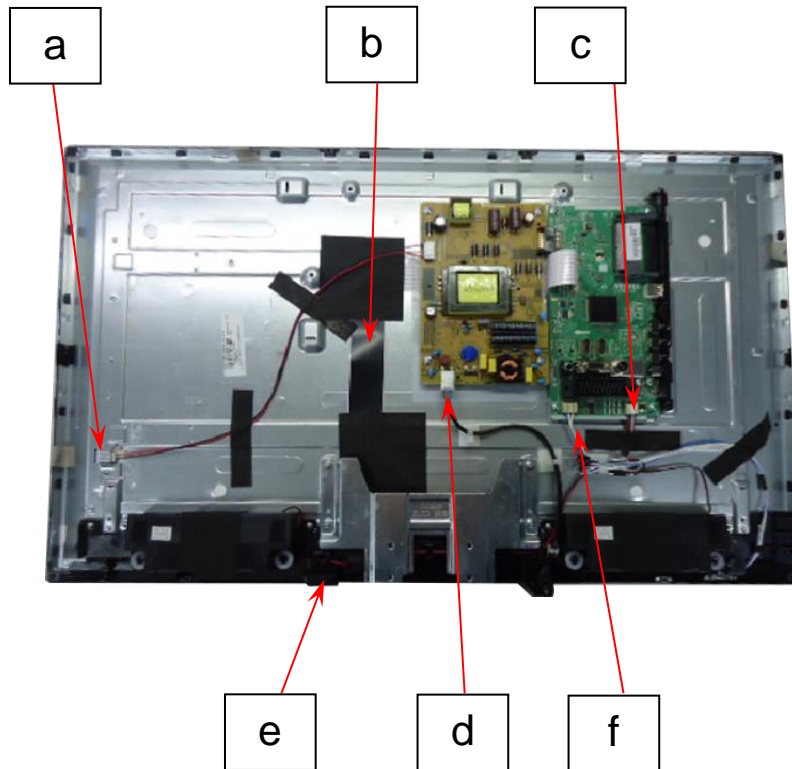

a	Back Light
b	LVDS Cable
c	Speaker connection
d	AC-Mains lead
e	Main power switch
f	IR-Remote Receiver

Location of Lead Wiring TX-39EW334

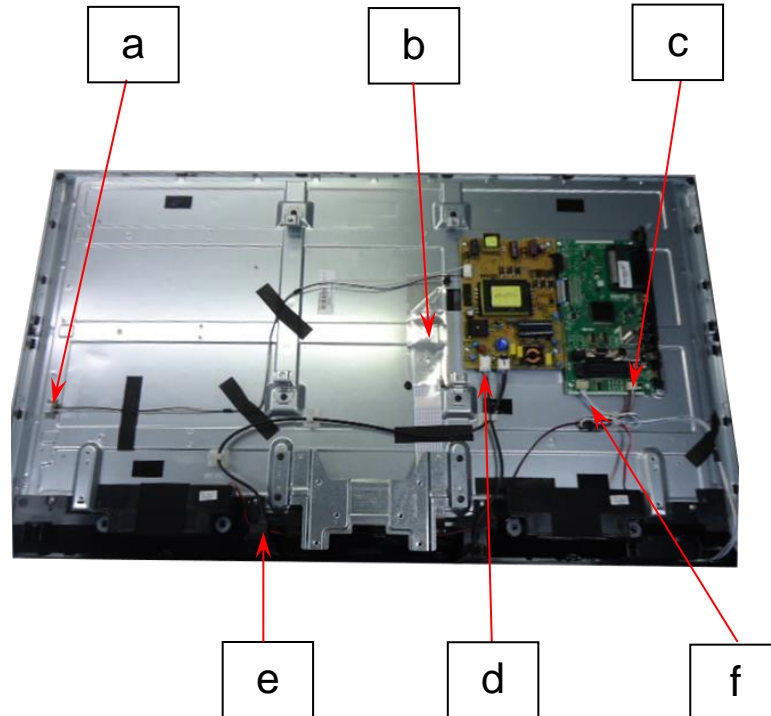

a	Back Light
b	LVDS Cable
c	Speaker connection
d	AC-Mains lead
e	Main power switch
f	IR-Remote Receiver

Location of Lead Wiring TX-43E200E / TX-43E303E / T-43E302

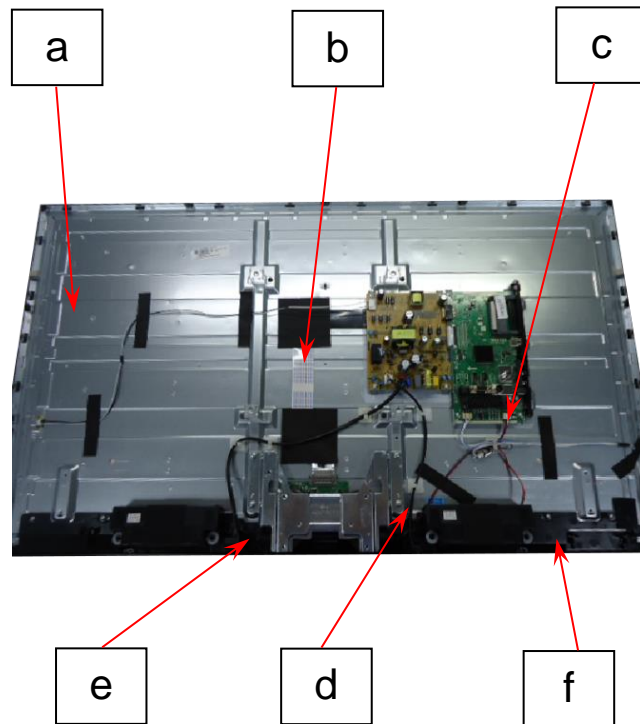

a	Back Light
b	LVDS Cable
c	Speaker connection
d	AC-Mains lead
e	Main power switch
f	IR-Remote Receiver

Block Diagram

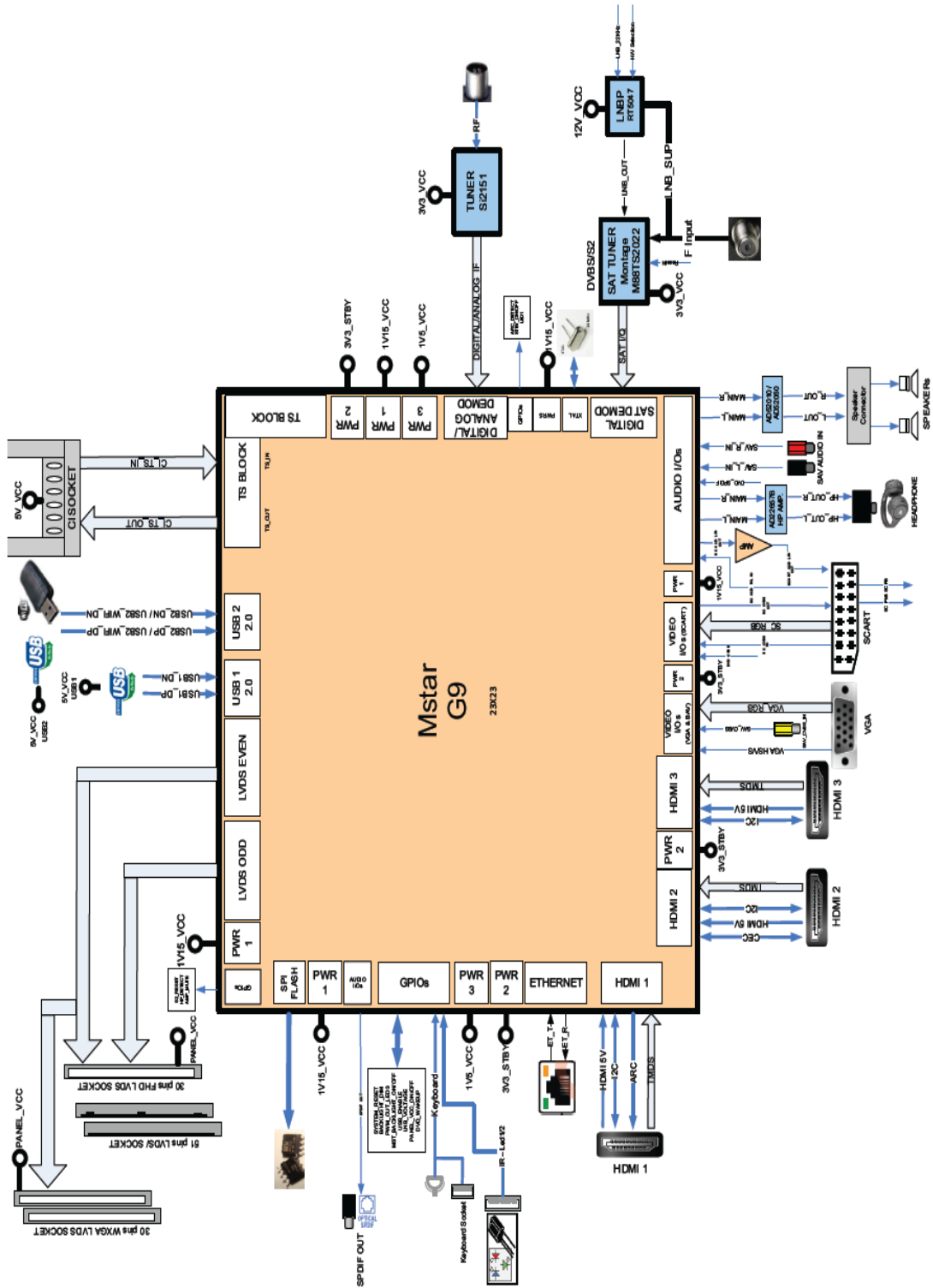

Exploded View (TX-24E200E / TX-24E303E / TX-24EW334 / TX-24E302)

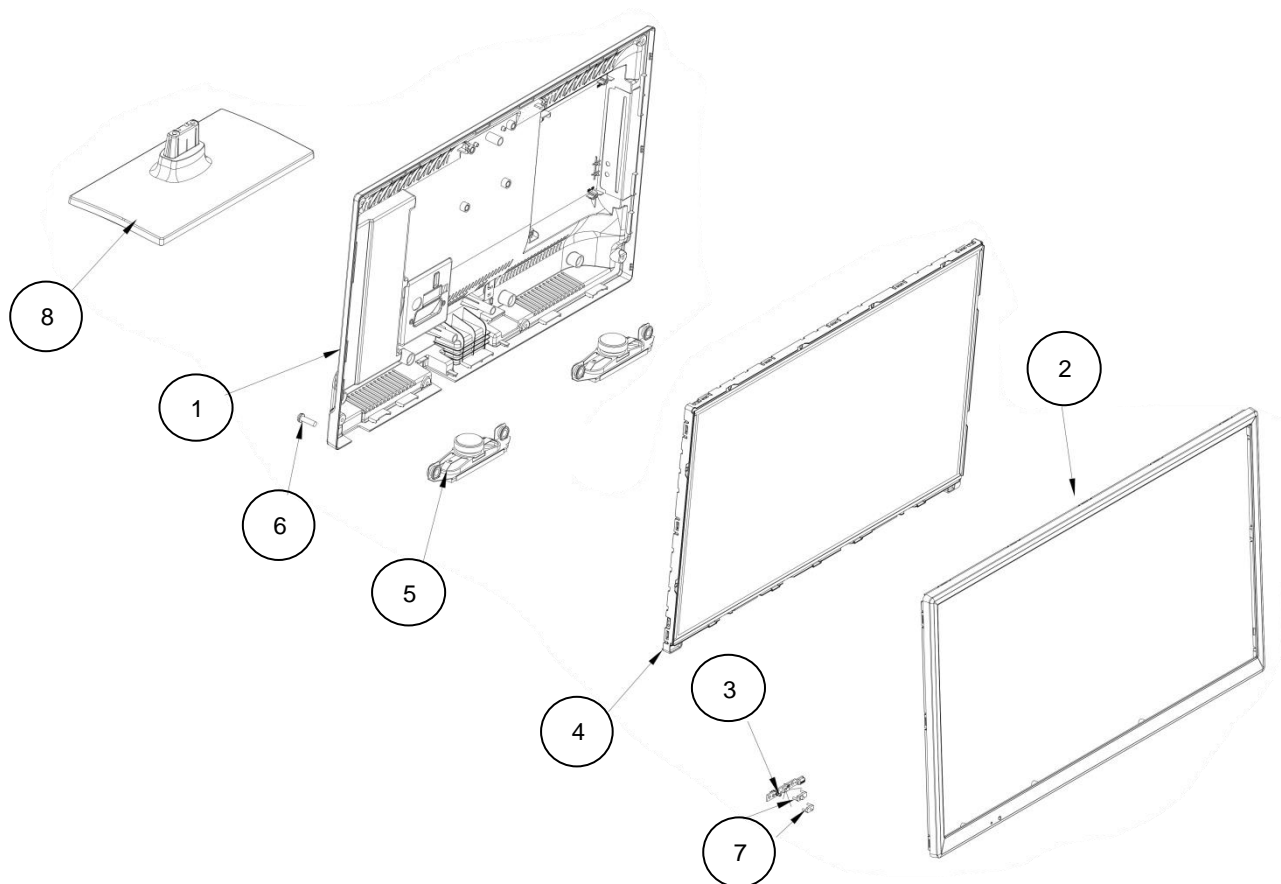

Pos.	Name	Qty
1	Rear Cover	
2	Front Cover	
3	IR-Remote Receiver Board	
4	Panel	
5	Speaker	
6	Rear cover Screw	
7	Lens	
8	Stand / Foot	

Exploded View (TX-32E200E / TX-32E303 / TX-32EW334 / TX-32E302)

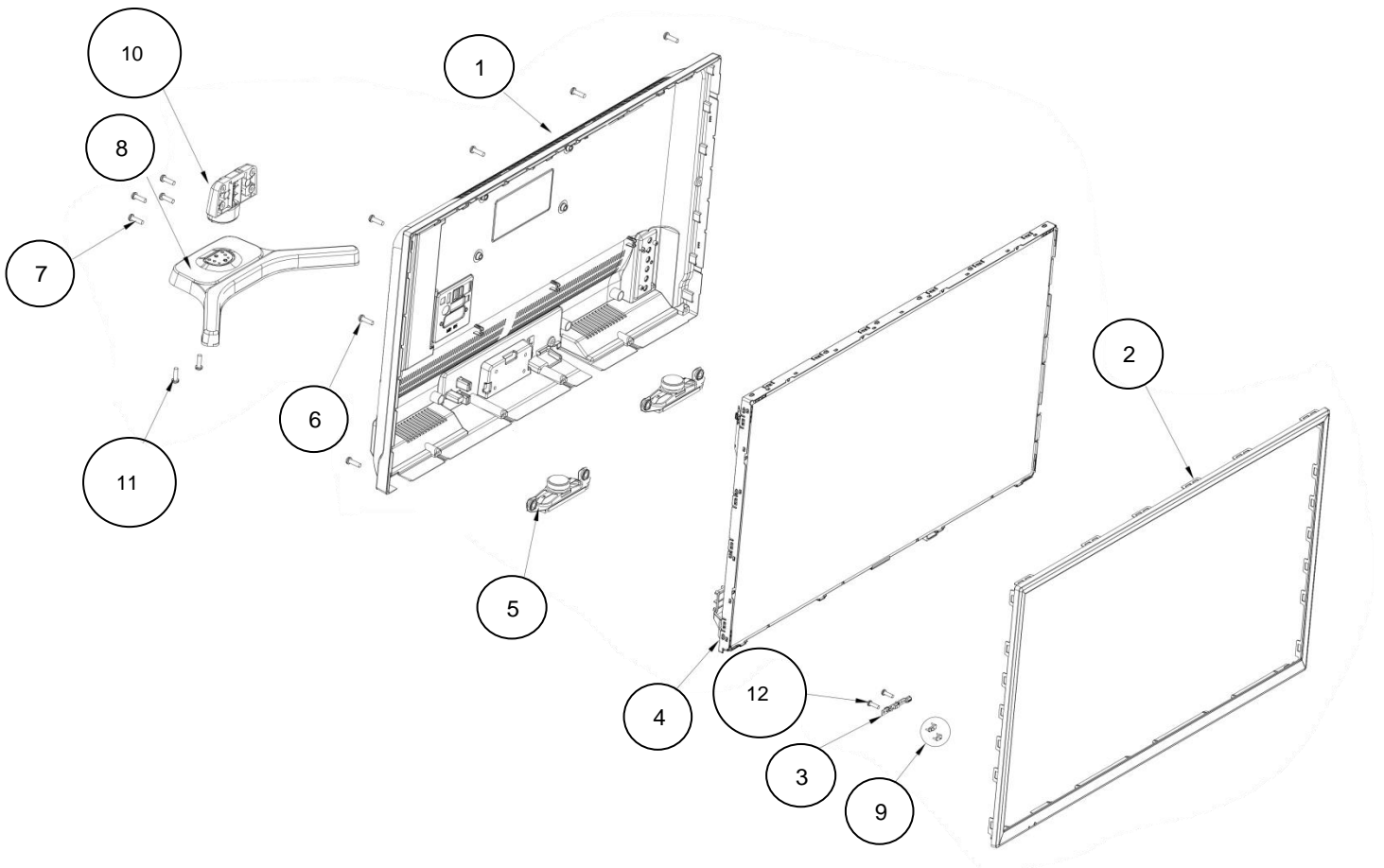

Pos.	Name	Qty
1	Rear Cover	
2	Front Cover	
3	IR-Remote Receiver Board	
4	Panel	
5	Speaker	
6	Rear cover Screw	
7	Foot Screw	
8	Stand / Foot	
9	Lens	
10	Neck	
11	Foot Screw	
12	Screws IR-Remote Receiver	

Exploded View (TX-39EW334)

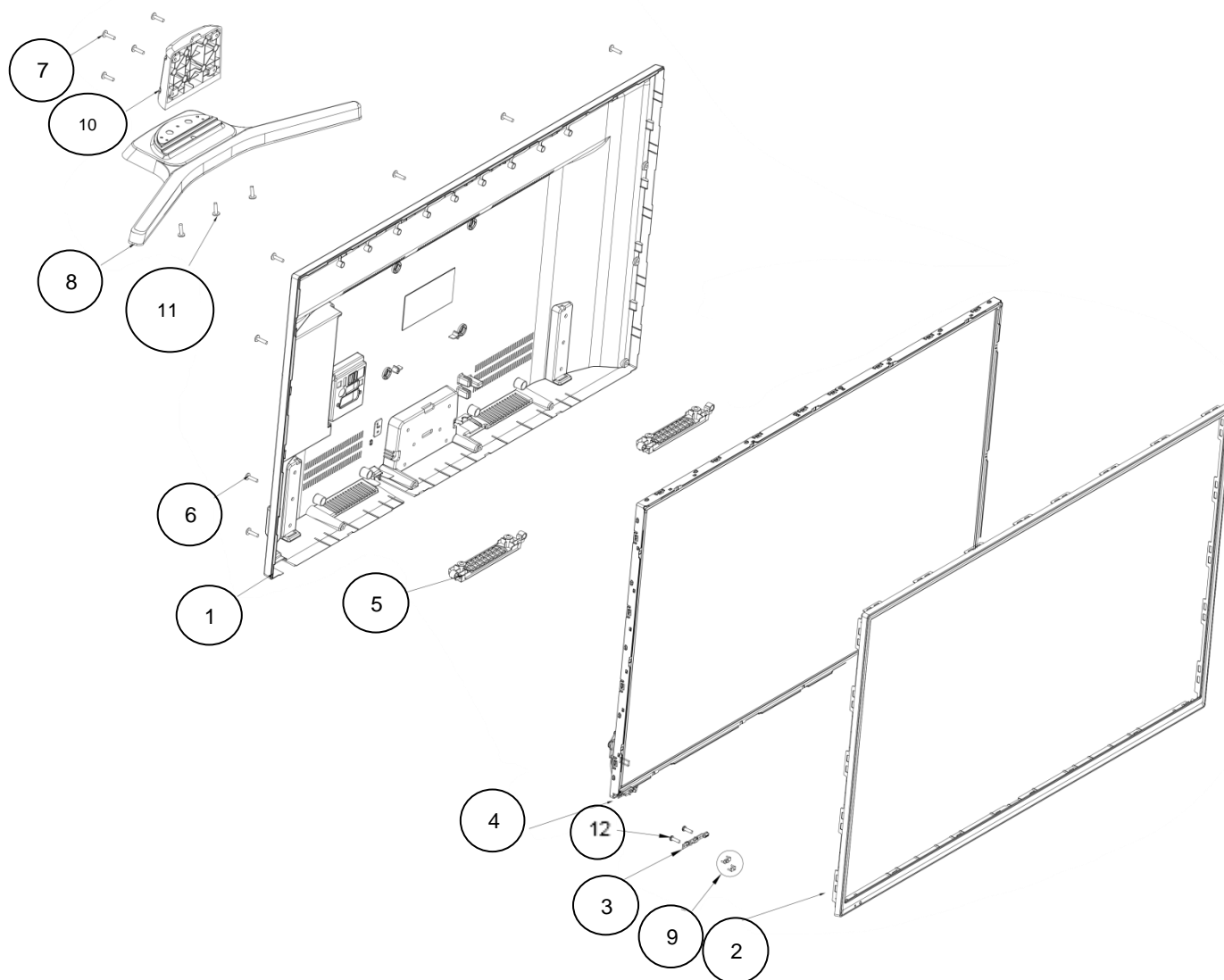

Pos.	Name	Qty
1	Rear Cover	
2	Front Cover	
3	IR-Remote Receiver Board	
4	Panel	
5	Speaker	
6	Rear cover Screw	
7	Foot Screw	
8	Stand / Foot	
9	Lens	
10	Neck	
11	Foot Screw	
12	Screws IR-Remote Receiver	

Exploded View (TX-43E200E / TX-43E303E / TX-43E302)

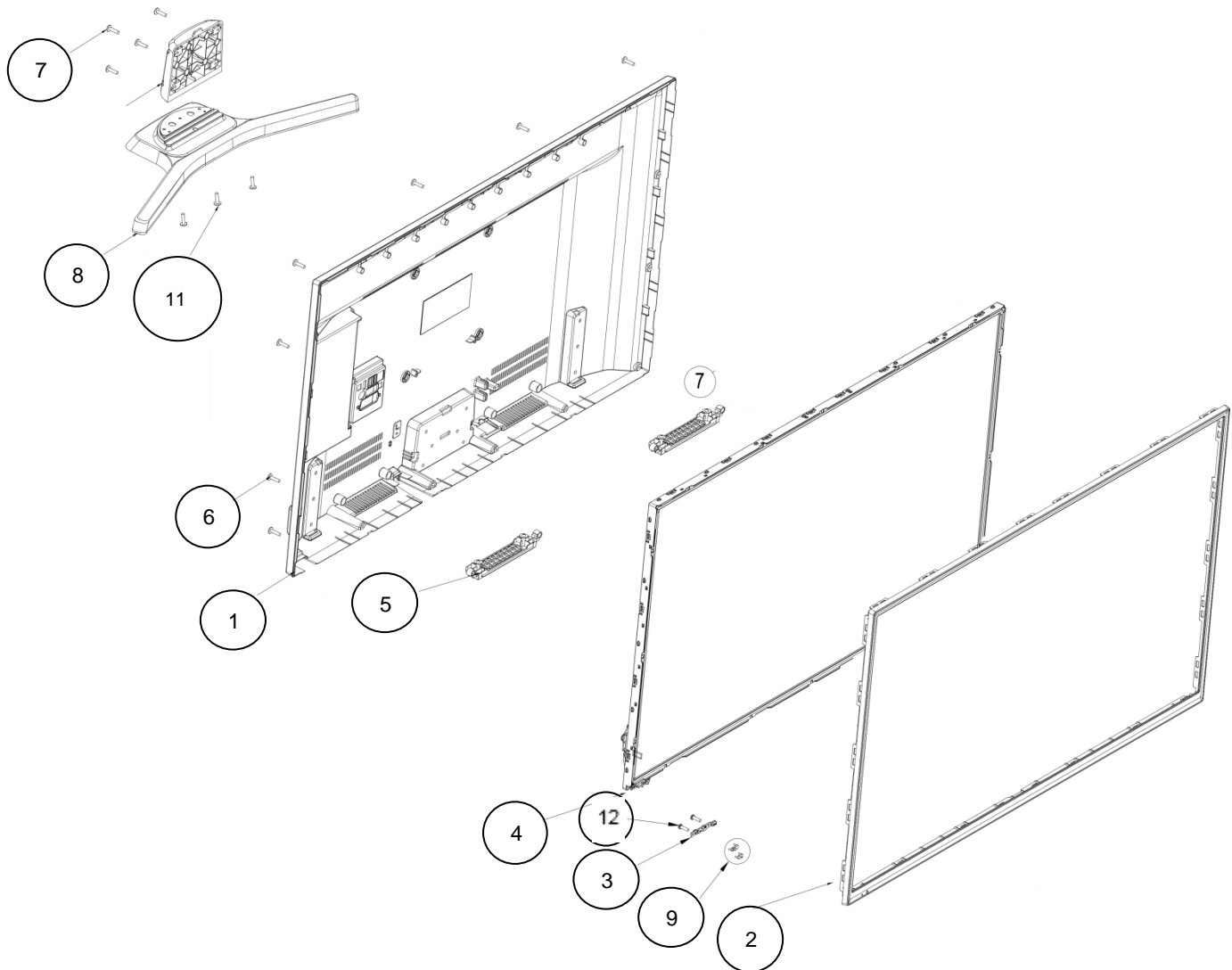

Pos.	Name	Qty
1	Rear Cover	
2	Front Cover	
3	IR-Remote Receiver Board	
4	Panel	
5	Speaker	
6	Rear cover Screw	
7	Foot Screw	
8	Stand / Foot	
9	Lens	
10	Neck	
11	Foot Screw	
12	Screws IR-Romote receiver	